

**N32G45x series**

**32-bit ARM<sup>®</sup> Cortex<sup>®</sup>-M4 microcontroller**

User manual V3.5.0

# Contents

|   |           |
|---|-----------|
| <b>1 Abbreviations in the text .....</b>                                  | <b>35</b> |
| 1.1 List of abbreviations for registers .....                             | 35        |
| 1.2 Available peripherals .....   | 35        |
| <b>2 Interrupts and events.....</b>                                       | <b>36</b> |
| 2.1 Nested vectored interrupt controller .....                            | 36        |
| 2.1.1 SysTick calibration value register.....                             | 36        |
| 2.1.2 Interrupt and exception vectors.....                                | 36        |
| 2.2 External interrupt/event controller (EXTI) .....                      | 39        |
| 2.2.1 Introduction .....  | 39        |
| 2.2.2 Main features.....  | 39        |
| 2.2.3 Functional description.....   | 40        |
| 2.2.4 EXTI line mapping.....  | 41        |
| 2.3 EXTI registers .....  | 43        |
| 2.3.1 EXTI register review .....  | 43        |
| 2.3.2 EXTI interrupt mask register (EXTI_IMASK) .....                     | 43        |
| 2.3.3 EXTI event mask register (EXTI_EMASK) .....                         | 43        |
| 2.3.4 Rising trigger selection register (EXTI_RT_CFG).....                | 44        |
| 2.3.5 Falling trigger selection register (EXTI_FT_CFG) .....              | 44        |
| 2.3.6 EXTI software interrupt event register (EXTI_SWIE) .....            | 45        |
| 2.3.7 EXTI pending register (EXTI_PEND) .....                             | 45        |
| 2.3.8 EXTI timestamp trigger source selection register (EXTI_TS_SEL)..... | 46        |
| <b>3 Memory and bus architecture.....</b>                                 | <b>47</b> |
| 3.1 System architecture.....  | 47        |
| 3.1.1 Bus architecture.....   | 47        |
| 3.1.2 Bus address mapping.....  | 48        |
| 3.1.3 Boot management .....   | 50        |
| 3.2 Memory system .....   | 51        |
| 3.2.1 FLASH specification.....  | 51        |
| 3.2.2 iCache.....   | 63        |
| 3.2.3 SRAM.....   | 64        |
| 3.2.4 R-SRAM (Retention SRAM) .....                                       | 65        |
| 3.2.5 FLASH register.....   | 65        |
| <b>4 Power control (PWR) .....</b>  | <b>74</b> |
| 4.1 General description.....  | 74        |
| 4.1.1 Power supply .....  | 74        |
| 4.1.2 Power supply supervisor .....                                       | 76        |
| 4.2 Power modes .....   | 78        |
| 4.2.1 SLEEP mode.....   | 82        |
| 4.2.2 STOP0 mode.....   | 83        |

|   |           |
|---|-----------|
| 4.2.3 STOP2 mode.....                                       | 84        |
| 4.2.4 STANDBY mode.....                                     | 84        |
| 4.2.5 VBAT mode.....  | 85        |
| 4.3 Low-power auto-wakeup (AWU) mode.....                   | 86        |
| 4.4 PWR registers.....                                      | 86        |
| 4.4.1 PWR register overview.....                            | 86        |
| 4.4.2 Power control register (PWR_CTRL).....                | 86        |
| 4.4.3 Power control status register(PWR_CTRLSTS).....       | 88        |
| 4.4.4 Power control register 2 (PWR_CTRL2).....             | 89        |
| 4.4.5 Power control register 3 (PWR_CTRL3).....             | 90        |
| <b>5 Backup registers (BKP).....</b>                        | <b>91</b> |
| 5.1 Introduction.....                                       | 91        |
| 5.2 Main features.....                                      | 91        |
| 5.3 Function description.....                               | 91        |
| 5.4 BKP registers.....                                      | 92        |
| 5.4.1 BKP register overview.....                            | 92        |
| 5.4.2 Backup Data Register x (BKP_DATx) (x = 1 ... 42)..... | 94        |
| 5.4.3 Backup Control Register (BKP_CTRL).....               | 94        |
| 5.4.4 Backup Control/Status Register (BKP_CTRLSTS).....     | 95        |
| <b>6 Reset and clock control (RCC).....</b>                 | <b>97</b> |
| 6.1 Reset Control Unit.....                                 | 97        |
| 6.1.1 Power reset.....                                      | 97        |
| 6.1.2 System reset.....                                     | 97        |
| 6.1.3 Backup domain reset.....                              | 98        |
| 6.2 Clock control unit.....                                 | 99        |
| 6.2.1 Clock Tree Diagram.....                               | 100       |
| 6.2.2 HSE clock.....  | 100       |
| 6.2.3 HSI clock.....  | 101       |
| 6.2.4 PLL clock.....  | 102       |
| 6.2.5 LSE clock.....  | 102       |
| 6.2.6 LSI clock.....  | 102       |
| 6.2.7 System clock (SYSCLK) selection.....                  | 103       |
| 6.2.8 Clock security system (CLKSS).....                    | 103       |
| 6.2.9 RTC clock.....  | 103       |
| 6.2.10 Watchdog clock.....                                  | 104       |
| 6.2.11 Clock output(MCO).....                               | 104       |
| 6.3 RCC Registers.....                                      | 104       |
| 6.3.1 RCC register overview.....                            | 104       |
| 6.3.2 Clock Control Register (RCC_CTRL).....                | 105       |
| 6.3.3 Clock Configuration Register (RCC_CFG).....           | 107       |
| 6.3.4 Clock Interrupt Register (RCC_CLKINT).....            | 110       |
| 6.3.5 APB2 Peripheral Reset Register (RCC_APB2PRST).....    | 112       |
| 6.3.6 APB1 Peripheral Reset Register (RCC_APB1PRST).....    | 114       |

|  |            |
|--|------------|
| 6.3.7 AHB Peripheral Clock Enable Register (RCC_AHBCLKEN) .....              | 117        |
| 6.3.8 APB2 Peripheral Clock Enable Register (RCC_APB2CLKEN) .....            | 119        |
| 6.3.9 APB1 Peripheral Clock Enable Register (RCC_APB1CLKEN) .....            | 121        |
| 6.3.10 Backup Domain Control Register (RCC_BDCTRL).....                      | 123        |
| 6.3.11 Clock Control/Status Register (RCC_CTRLSTS).....                      | 124        |
| 6.3.12 AHB Peripheral Reset Register (RCC_AHBPRST) .....                     | 126        |
| 6.3.13 Clock Configuration Register 2 (RCC_CFG2).....                        | 128        |
| 6.3.14 Clock Configuration Register 3 (RCC_CFG3).....                        | 129        |
| <b>7 GPIO and AFIO .....</b>   | <b>131</b> |
| 7.1 Summary.....   | 131        |
| 7.2 I/O function description.....  | 132        |
| 7.2.1 I/O mode configuration .....   | 132        |
| 7.2.2 Status after reset .....   | 137        |
| 7.2.3 Individual bit setting and bit clearing .....                          | 138        |
| 7.2.4 External interrupt/wake-up line.....                                   | 138        |
| 7.2.5 Alternate function .....   | 138        |
| 7.2.6 I/O configuration of peripherals.....                                  | 149        |
| 7.2.7 GPIO locking mechanism.....  | 154        |
| 7.3 GPIO registers .....   | 154        |
| 7.3.1 GPIO register overview.....  | 155        |
| 7.3.2 GPIO port low configuration register (GPIOx_PL_CFG).....               | 156        |
| 7.3.3 GPIO port high configuration register (GPIOx_PH_CFG).....              | 157        |
| 7.3.4 GPIO port input data register (GPIOx_PID).....                         | 158        |
| 7.3.5 GPIO port output data register (GPIOx_POD) .....                       | 158        |
| 7.3.6 GPIO port bit setting/clearing register (GPIOx_PBSC) .....             | 159        |
| 7.3.7 GPIO port bit clear register (GPIOx_PBC).....                          | 159        |
| 7.3.8 GPIO port lock configuration register (GPIOx_PLOCK_CFG).....           | 160        |
| 7.3.9 GPIO driver capability configuration register (GPIOx_DS_CFG) .....     | 161        |
| 7.3.10 GPIO flip rate configuration register (GPIOx_SR_CFG).....             | 161        |
| 7.4 AFIO registers .....   | 162        |
| 7.4.1 AFIO register overview .....   | 162        |
| 7.4.2 AFIO event control register (AFIO_ECTRL) .....                         | 163        |
| 7.4.3 AFIO alternate remap configuration register (AFIO_RMP_CFG) .....       | 163        |
| 7.4.4 AFIO external interrupt configuration register 1(AFIO_EXTI_CFG1) ..... | 167        |
| 7.4.5 AFIO external interrupt configuration register 2(AFIO_EXTI_CFG2) ..... | 168        |
| 7.4.6 AFIO external interrupt configuration register 3(AFIO_EXTI_CFG3) ..... | 168        |
| 7.4.7 AFIO external interrupt configuration register 4(AFIO_EXTI_CFG4) ..... | 169        |
| 7.4.8 AFIO alternate remapping configuration register 3(AFIO_RMP_CFG3) ..... | 170        |
| 7.4.9 AFIO alternate remap configuration register 4 (AFIO_RMP_CFG4) .....    | 173        |
| 7.4.10 AFIO alternate remapping configuration register 5(AFIO_RMP_CFG5)..... | 175        |
| <b>8 DMA controller .....</b>  | <b>178</b> |
| 8.1 Introduction .....   | 178        |
| 8.2 Main features .....  | 178        |

|   |            |
|---|------------|
| 8.3 Block diagram .....   | 179        |
| 8.4 Function description .....  | 179        |
| 8.4.1 DMA operation.....  | 179        |
| 8.4.2 Channel priority and arbitration.....                             | 180        |
| 8.4.3 DMA channels and number of transfers.....                         | 180        |
| 8.4.4 Programmable data bit width.....                                  | 180        |
| 8.4.5 Peripheral/Memory address incrementation .....                    | 182        |
| 8.4.6 Channel configuration procedure.....                              | 182        |
| 8.4.7 Flow control .....  | 183        |
| 8.4.8 Circular mode.....  | 183        |
| 8.4.9 Error management.....   | 183        |
| 8.4.10 Interrupt.....   | 184        |
| 8.4.11 DMA request mapping .....  | 184        |
| 8.5 DMA registers .....   | 188        |
| 8.5.1 DMA register overview.....  | 188        |
| 8.5.2 DMA interrupt status register (DMA_INTSTS) .....                  | 190        |
| 8.5.3 DMA interrupt flag clear register (DMA_INTCLR) .....              | 190        |
| 8.5.4 DMA channel x configuration register (DMA_CHCFGx).....            | 191        |
| 8.5.5 DMA channel x transfer number register (DMA_TXNUMx).....          | 193        |
| 8.5.6 DMA channel x peripheral address register (DMA_PADDRx) .....      | 193        |
| 8.5.7 DMA channel x memory address register (DMA_MADDRx).....           | 194        |
| 8.5.8 DMA1 channel x channel request select register (DMA1_CHSELx)..... | 194        |
| 8.5.9 DMA2 channel x channel request select register (DMA2_CHSELx)..... | 196        |
| 8.5.10 DMA channel MAP enable register (DMA_CHMAPEN).....               | 197        |
| <b>9 Analog to digital conversion (ADC).....</b>                        | <b>198</b> |
| 9.1 Introduction .....  | 198        |
| 9.2 Main features.....  | 198        |
| 9.3 Function Description.....   | 199        |
| 9.3.1 ADC clock.....  | 200        |
| 9.3.2 ADC switch control.....   | 201        |
| 9.3.3 Channel selection.....  | 201        |
| 9.3.4 Internal channel .....  | 205        |
| 9.3.5 Single conversion mode .....                                      | 205        |
| 9.3.6 Continuous conversion mode .....                                  | 205        |
| 9.3.7 Timing diagram .....  | 206        |
| 9.3.8 Analog watchdog.....  | 206        |
| 9.3.9 Scanning mode .....   | 207        |
| 9.3.10 Injection channel management .....                               | 207        |
| 9.3.11 Discontinuous mode .....   | 208        |
| 9.4 Calibration .....   | 209        |
| 9.5 Data aligned .....  | 209        |
| 9.6 Programmable channel sampling time .....                            | 210        |
| 9.7 Externally triggered conversion.....                                | 211        |
| 9.8 DMA requests .....  | 212        |

|   |            |
|---|------------|
| 9.9 ADC Mode.....   | 212        |
| 9.9.1 Independent mode.....   | 213        |
| 9.9.2 Synchronous regular mode .....  | 214        |
| 9.9.3 Synchronous injection mode .....  | 214        |
| 9.9.4 Fast alternate mode.....  | 215        |
| 9.9.5 Slow alternate mode .....   | 216        |
| 9.9.6 Rotation trigger Mode .....   | 217        |
| 9.9.7 Mixed synchronous regular mode + synchronous injection mode.....              | 218        |
| 9.9.8 Mixed synchronous regular mode + rotation trigger mode.....                   | 218        |
| 9.9.9 Mixed synchronous injection mode + alternate mode.....                        | 219        |
| 9.10 Temperature sensor.....  | 220        |
| 9.10.1 Temperature sensor using flow .....  | 221        |
| 9.11 ADC interrupt .....  | 221        |
| 9.12 ADC registers.....   | 222        |
| 9.12.1 ADC register overview.....   | 222        |
| 9.12.2 ADC status register (ADC_STS) .....  | 223        |
| 9.12.3 ADC control register 1 (ADC_CTRL1) .....                                     | 224        |
| 9.12.4 ADC control register 2 (ADC_CTRL2) .....                                     | 226        |
| 9.12.5 ADC sampling time register 1 (ADC_SAMPT1).....                               | 229        |
| 9.12.6 ADC sampling time register 2 (ADC_SAMPT2).....                               | 229        |
| 9.12.7 ADC injected channel data offset register x (ADC_JOFFSETx) (x=1 ... 4) ..... | 230        |
| 9.12.8 ADC watchdog high threshold register (ADC_WDGHIGH).....                      | 230        |
| 9.12.9 ADC watchdog low threshold register (ADC_WDGLOW).....                        | 231        |
| 9.12.10 ADC regular sequence register 1 (ADC_RSEQ1) .....                           | 231        |
| 9.12.11 ADC regular sequence register 2 (ADC_RSEQ2).....                            | 232        |
| 9.12.12 ADC regular sequence register 3 (ADC_RSEQ3) .....                           | 232        |
| 9.12.13 ADC Injection sequence register (ADC_JSEQ) .....                            | 233        |
| 9.12.14 ADC injection data register x (ADC_JDATx) (x= 1 ... 4) .....                | 233        |
| 9.12.15 ADC regulars data register (ADC_DAT).....                                   | 234        |
| 9.12.16 ADC differential mode selection register (ADC_DIFSEL).....                  | 234        |
| 9.12.17 ADC calibration factor (ADC_CALFACT).....                                   | 235        |
| 9.12.18 ADC control register 3 (ADC_CTRL3).....                                     | 235        |
| 9.12.19 ADC sampling time register 3 (ADC_SAMPT3).....                              | 237        |
| <b>10 Digital to analog conversion (DAC).....</b>                                   | <b>238</b> |
| 10.1 Introduction .....   | 238        |
| 10.2 Main features .....  | 238        |
| 10.3 DAC function description and operation description .....                       | 240        |
| 10.3.1 DAC enable .....   | 240        |
| 10.3.2 DAC output buffer.....   | 240        |
| 10.3.3 DAC data format .....  | 240        |
| 10.3.4 DAC trigger.....   | 242        |
| 10.3.5 DAC conversion.....  | 243        |
| 10.3.6 DAC output voltage.....  | 243        |
| 10.3.7 DMA requests .....   | 243        |

|           |  |            |
|-----------|--|------------|
| 10.3.8    | The noise.....   | 244        |
| 10.3.9    | Triangular wave generation .....   | 245        |
| 10.4      | DAC dual-channel conversion.....   | 246        |
| 10.4.1    | Independent trigger without waveform generator .....                     | 246        |
| 10.4.2    | Independent triggers producing the same noise .....                      | 246        |
| 10.4.3    | Independent triggers that generate different noises .....                | 247        |
| 10.4.4    | Independent triggers that generate the same triangle wave.....           | 247        |
| 10.4.5    | Independent trigger to generate different triangle waves.....            | 248        |
| 10.4.6    | Simultaneous software startup.....                                       | 248        |
| 10.4.7    | Synchronous trigger without waveform generator .....                     | 249        |
| 10.4.8    | Synchronous triggers that generate the same noise.....                   | 249        |
| 10.4.9    | Synchronous triggers that generate different noises.....                 | 249        |
| 10.4.10   | Synchronous trigger to generate the same triangle wave.....              | 250        |
| 10.4.11   | Synchronous trigger to generate different triangle waves .....           | 250        |
| 10.5      | DAC register.....  | 251        |
| 10.5.1    | DAC registers overview.....  | 251        |
| 10.5.2    | DAC control register (DAC_CTRL) .....                                    | 251        |
| 10.5.3    | DAC software trigger register (DAC_SOTTR).....                           | 254        |
| 10.5.4    | 12 bit right aligned data hold register for DAC1 (DAC_DR12CH1).....      | 254        |
| 10.5.5    | 12 bit left aligned data hold register for DAC1 (DAC_DL12CH1).....       | 255        |
| 10.5.6    | 8-bit right-aligned data hold register for DAC1 (DAC_DR8CH1) .....       | 255        |
| 10.5.7    | 12 bit right aligned data hold register for DAC2 (DAC_DR12CH2).....      | 256        |
| 10.5.8    | 12 bit left aligned data hold register for DAC2 (DAC_DL12CH2).....       | 256        |
| 10.5.9    | 8-bit right-aligned data hold register for DAC2 (DAC_DR8CH2) .....       | 256        |
| 10.5.10   | 12 bit right aligned data hold register for dual DAC (DAC_DR12DCH) ..... | 257        |
| 10.5.11   | 12 bit left aligned data hold register for dual DAC (DAC_DL12DCH) .....  | 257        |
| 10.5.12   | 8 bit right aligned data hold register for dual DAC (DAC_DR8DCH) .....   | 258        |
| 10.5.13   | DAC1 data output register (DAC_DATO1).....                               | 258        |
| 10.5.14   | DAC2 data output register (DAC_DATO2).....                               | 258        |
| <b>11</b> | <b>Advanced-control timers (TIM1 and TIM8).....</b>                      | <b>260</b> |
| 11.1      | TIM1 and TIM8 introduction .....   | 260        |
| 11.2      | Main features of TIM1 and TIM8 .....                                     | 260        |
| 11.3      | TIM1 and TIM8 function description.....                                  | 261        |
| 11.3.1    | Time-base unit .....   | 261        |
| 11.3.2    | Counter mode .....   | 262        |
| 11.3.3    | Repetition counter.....  | 267        |
| 11.3.4    | Clock selection.....   | 270        |
| 11.3.5    | Capture/compare channels .....   | 273        |
| 11.3.6    | Input capture mode .....   | 276        |
| 11.3.7    | PWM input mode .....   | 277        |
| 11.3.8    | Forced output mode .....   | 278        |
| 11.3.9    | Output compare mode .....  | 278        |
| 11.3.10   | PWM mode .....   | 280        |
| 11.3.11   | One-pulse mode .....   | 283        |

|  |            |
|--|------------|
| 11.3.12 Clearing the OCxREF signal on an external event .....      | 284        |
| 11.3.13 Complementary outputs with dead-time insertion .....       | 285        |
| 11.3.14 Break function.....  | 287        |
| 11.3.15 Debug mode.....  | 288        |
| 11.3.16 TIMx and external trigger synchronization .....            | 289        |
| 11.3.17 Timer synchronization .....                                | 292        |
| 11.3.18 6-step PWM generation.....                                 | 292        |
| 11.3.19 Encoder interface mode.....                                | 293        |
| 11.3.20 Interfacing with Hall sensor .....                         | 296        |
| <b>11.4 TIMx register (x=1, 8) .....</b>                           | <b>298</b> |
| 11.4.1 Register Overview.....                                      | 298        |
| 11.4.2 Control register 1 (TIMx_CTRL1) .....                       | 299        |
| 11.4.3 Control register 2 (TIMx_CTRL2) .....                       | 301        |
| 11.4.4 Slave mode control register (TIMx_SMCTRL).....              | 303        |
| 11.4.5 DMA/Interrupt enable registers (TIMx_DINTEN) .....          | 305        |
| 11.4.6 Status registers (TIMx_STS) .....                           | 307        |
| 11.4.7 Event generation registers (TIMx_EVTGEN) .....              | 309        |
| 11.4.8 Capture/compare mode register 1 (TIMx_CCMOD1) .....         | 310        |
| 11.4.9 Capture/compare mode register 2 (TIMx_CCMOD2) .....         | 313        |
| 11.4.10 Capture/compare enable registers (TIMx_CCEN) .....         | 315        |
| 11.4.11 Counters (TIMx_CNT).....                                   | 318        |
| 11.4.12 Prescaler (TIMx_PSC) .....                                 | 318        |
| 11.4.13 Auto-reload register (TIMx_AR) .....                       | 318        |
| 11.4.14 Repeat count registers (TIMx_REPCNT).....                  | 318        |
| 11.4.15 Capture/compare register 1 (TIMx_CCDA1) .....              | 319        |
| 11.4.16 Capture/compare register 2 (TIMx_CCDA2) .....              | 319        |
| 11.4.17 Capture/compare register 3 (TIMx_CCDA3) .....              | 320        |
| 11.4.18 Capture/compare register 4 (TIMx_CCDA4) .....              | 320        |
| 11.4.19 Break and Dead-time registers (TIMx_BKDT) .....            | 321        |
| 11.4.20 DMA Control register (TIMx_DCTRL) .....                    | 323        |
| 11.4.21 DMA transfer buffer register (TIMx_DADDR).....             | 324        |
| 11.4.22 Capture/compare mode registers 3(TIMx_CCMOD3).....         | 324        |
| 11.4.23 Capture/compare register 5 (TIMx_CCDA5) .....              | 325        |
| 11.4.24 Capture/compare register 6 (TIMx_CCDA6) .....              | 325        |
| <b>12 General-purpose timers (TIM2, TIM3, TIM4 and TIM5) .....</b> | <b>327</b> |
| 12.1 General-purpose timers introduction.....                      | 327        |
| 12.2 Main features of General-purpose timers .....                 | 327        |
| 12.3 General-purpose timers description .....                      | 328        |
| 12.3.1 Time-base unit .....  | 328        |
| 12.3.2 Counter mode.....   | 329        |
| 12.3.3 Clock selection .....                                       | 334        |
| 12.3.4 Capture/compare channels.....                               | 338        |
| 12.3.5 Input capture mode .....                                    | 341        |
| 12.3.6 PWM input mode .....  | 342        |

|   |            |
|---|------------|
| 12.3.7 Forced output mode .....                               | 343        |
| 12.3.8 Output compare mode .....                              | 343        |
| 12.3.9 PWM mode .....   | 345        |
| 12.3.10 One-pulse mode .....                                  | 348        |
| 12.3.11 Clearing the OCxREF signal on an external event ..... | 349        |
| 12.3.12 Debug mode .....                                      | 350        |
| 12.3.13 TIMx and external trigger synchronization .....       | 350        |
| 12.3.14 Timer synchronization .....                           | 350        |
| 12.3.15 Encoder interface mode .....                          | 354        |
| 12.3.16 Interfacing with Hall sensor .....                    | 356        |
| <b>12.4 TIMx register description(x=2, 3 ,4 and 5).....</b>   | <b>356</b> |
| 12.4.1 Register Overview .....                                | 356        |
| 12.4.2 Control register 1 (TIMx_CTRL1) .....                  | 358        |
| 12.4.3 Control register 2 (TIMx_CTRL2) .....                  | 360        |
| 12.4.4 Slave mode control register (TIMx_SMCTRL) .....        | 361        |
| 12.4.5 DMA/Interrupt enable registers (TIMx_DINTEN) .....     | 364        |
| 12.4.6 Status registers (TIMx_STS).....                       | 365        |
| 12.4.7 Event generation registers (TIMx_EVTGEN).....          | 366        |
| 12.4.8 Capture/compare mode register 1 (TIMx_CCMOD1).....     | 367        |
| 12.4.9 Capture/compare mode register 2 (TIMx_CCMOD2).....     | 370        |
| 12.4.10 Capture/compare enable registers (TIMx_CCEN).....     | 372        |
| 12.4.11 Counters (TIMx_CNT) .....                             | 373        |
| 12.4.12 Prescaler (TIMx_PSC).....                             | 374        |
| 12.4.13 Auto-reload register (TIMx_AR).....                   | 374        |
| 12.4.14 Capture/compare register 1 (TIMx_CCDA1).....          | 374        |
| 12.4.15 Capture/compare register 2 (TIMx_CCDA2).....          | 375        |
| 12.4.16 Capture/compare register 3 (TIMx_CCDA3).....          | 375        |
| 12.4.17 Capture/compare register 4 (TIMx_CCDA4).....          | 376        |
| 12.4.18 DMA Control register (TIMx_DCTRL) .....               | 376        |
| 12.4.19 DMA transfer buffer register (TIMx_DADDR).....        | 377        |
| <b>13 Basic timers (TIM6 and TIM7) .....</b>                  | <b>379</b> |
| 13.1 Introduction.....  | 379        |
| 13.2 Main features.....                                       | 379        |
| 13.3 Basic timers description .....                           | 379        |
| 13.3.1 Time-base unit .....                                   | 379        |
| 13.3.2 Counter mode.....                                      | 380        |
| 13.3.3 Clock selection.....                                   | 383        |
| 13.3.4 Debug mode .....                                       | 383        |
| 13.4 TIMx register description(x = 6 and 7) .....             | 383        |
| 13.4.1 Register overview .....                                | 384        |
| 13.4.2 Control Register 1 (TIMx_CTRL1).....                   | 384        |
| 13.4.3 Control Register 2 (TIMx_CTRL2).....                   | 385        |
| 13.4.4 DMA/Interrupt Enable Registers (TIMx_DINTEN) .....     | 386        |
| 13.4.5 Status Registers (TIMx_STS).....                       | 387        |

|  |            |
|--|------------|
| 13.4.6 Event Generation registers ( <i>TIMx_EVTGEN</i> ).....      | 387        |
| 13.4.7 Counter ( <i>TIMx_CNT</i> ).....                            | 388        |
| 13.4.8 Prescaler ( <i>TIMx_PSC</i> ).....                          | 388        |
| 13.4.9 Automatic reload register ( <i>TIMx_AR</i> ).....           | 388        |
| <b>14 Real-time clock (RTC).....</b>                               | <b>390</b> |
| 14.1 Description.....  | 390        |
| 14.1.1 Specification.....  | 390        |
| 14.2 RTC function description.....                                 | 391        |
| 14.2.1 RTC block diagram.....                                      | 391        |
| 14.2.2 GPIOs of RTC.....   | 392        |
| 14.2.3 RTC register write protection.....                          | 392        |
| 14.2.4 RTC clock and prescaler.....                                | 392        |
| 14.2.5 RTC calendar.....   | 393        |
| 14.2.6 Calendar initialization and configuration.....              | 393        |
| 14.2.7 Calendar reading.....                                       | 393        |
| 14.2.8 Calibration clock output.....                               | 394        |
| 14.2.9 Programmable alarms.....                                    | 394        |
| 14.2.10 Alarm configuration.....                                   | 395        |
| 14.2.11 Alarm output.....  | 395        |
| 14.2.12 Periodic automatic wakeup.....                             | 395        |
| 14.2.13 Wakeup timer configuration.....                            | 396        |
| 14.2.14 Timestamp function.....                                    | 396        |
| 14.2.15 Daylight saving time configuration.....                    | 396        |
| 14.2.16 RTC sub-second register shift.....                         | 396        |
| 14.2.17 RTC digital clock precision calibration.....               | 397        |
| 14.2.18 RTC low power mode.....                                    | 398        |
| 14.3 RTC Registers.....  | 398        |
| 14.3.1 RTC Register overview.....                                  | 398        |
| 14.3.2 RTC Calendar Time Register ( <i>RTC_TSH</i> ).....          | 399        |
| 14.3.3 RTC Calendar Date Register ( <i>RTC_DATE</i> ).....         | 400        |
| 14.3.4 RTC Control Register ( <i>RTC_CTRL</i> ).....               | 401        |
| 14.3.5 RTC Initial Status Register ( <i>RTC_INITSTS</i> ).....     | 403        |
| 14.3.6 RTC Prescaler Register ( <i>RTC_PRE</i> ).....              | 405        |
| 14.3.7 RTC Wakeup Timer Register ( <i>RTC_WKUPT</i> ).....         | 405        |
| 14.3.8 RTC Alarm A Register ( <i>RTC_ALARMA</i> ).....             | 406        |
| 14.3.9 RTC Alarm B Register ( <i>RTC_ALARMB</i> ).....             | 407        |
| 14.3.10 RTC Write Protection register ( <i>RTC_WRP</i> ).....      | 407        |
| 14.3.11 RTC Sub-second Register ( <i>RTC_SUBS</i> ).....           | 408        |
| 14.3.12 RTC Shift Control Register ( <i>RTC_SCTRL</i> ).....       | 408        |
| 14.3.13 RTC Timestamp Time Register ( <i>RTC_TST</i> ).....        | 409        |
| 14.3.14 RTC Timestamp Date Register ( <i>RTC_TSD</i> ).....        | 410        |
| 14.3.15 RTC Timestamp Sub-second Register ( <i>RTC_TSSS</i> )..... | 410        |
| 14.3.16 RTC Calibration Register ( <i>RTC_CALIB</i> ).....         | 411        |
| 14.3.17 RTC Alarm A sub-second register ( <i>RTC_ALRMAS</i> )..... | 412        |

|  |            |
|--|------------|
| 14.3.18 RTC Alarm B sub-second register (RTC_ALRMBSS).....         | 412        |
| 14.3.19 RTC Option Register (RTC_OPT).....                         | 413        |
| <b>15 CRC calculation unit .....</b>                               | <b>414</b> |
| 15.1 Introduction .....  | 414        |
| 15.2 Main features .....   | 414        |
| 15.2.1 CRC32 .....   | 414        |
| 15.2.2 CRC16 .....   | 414        |
| 15.3 Function description .....                                    | 415        |
| 15.3.1 CRC32 .....   | 415        |
| 15.3.2 CRC16 .....   | 415        |
| 15.4 CRC registers.....  | 416        |
| 15.4.1 CRC register overview.....                                  | 416        |
| 15.4.2 CRC32 data register (CRC_CRC32DAT).....                     | 416        |
| 15.4.3 CRC32 independent data register (CRC_CRC32IDAT).....        | 416        |
| 15.4.4 CRC32 control register (CRC_CRC32CTRL) .....                | 417        |
| 15.4.5 CRC16 control register (CRC_CRC16CTRL) .....                | 417        |
| 15.4.6 CRC16 input data register (CRC_CRC16DAT) .....              | 418        |
| 15.4.7 CRC cyclic redundancy check code register (CRC_CRC16D)..... | 418        |
| 15.4.8 LRC result register (CRC_LRC).....                          | 419        |
| <b>16 Independent watchdog (IWDG) .....</b>                        | <b>420</b> |
| 16.1 Introduction .....  | 420        |
| 16.2 Main features .....   | 420        |
| 16.3 Functional description .....                                  | 421        |
| 16.3.1 Register access protection .....                            | 421        |
| 16.3.2 Debug mode.....   | 422        |
| 16.4 User interface.....   | 422        |
| 16.4.1 Operate flow.....   | 422        |
| 16.4.2 IWDG configuration flow .....                               | 423        |
| 16.5 IWDG registers.....   | 424        |
| 16.5.1 IWDG register overview .....                                | 424        |
| 16.5.2 IWDG key register (IWDG_KEY).....                           | 424        |
| 16.5.3 IWDG pre-scaler register (IWDG_PREDIV) .....                | 424        |
| 16.5.4 IWDG reload register (IWDG_RELV).....                       | 425        |
| 16.5.5 IWDG status register (IWDG_STS).....                        | 426        |
| <b>17 Window watchdog (WWDG) .....</b>                             | <b>427</b> |
| 17.1 Introduction .....  | 427        |
| 17.2 Main features .....   | 427        |
| 17.3 Function description .....                                    | 427        |
| 17.4 Timing for refresh watchdog and interrupt generation .....    | 428        |
| 17.5 Debug mode.....   | 429        |
| 17.6 User interface.....   | 429        |
| 17.6.1 WWDG configuration flow .....                               | 429        |

|  |            |
|--|------------|
| 17.7 WWDG registers .....  | 430        |
| 17.7.1 WWDG register overview .....                              | 430        |
| 17.7.2 WWDG control register (WWDG_CTRL).....                    | 430        |
| 17.7.3 WWDG config register (WWDG_CFG).....                      | 430        |
| 17.7.4 WWDG status register (WWDG_STS).....                      | 431        |
| <b>18 SDIO Interface (SDIO) .....</b>                            | <b>432</b> |
| 18.1 Main features of SDIO .....                                 | 432        |
| 18.2 SDIO bus topology .....                                     | 432        |
| 18.3 SDIO function description.....                              | 434        |
| 18.3.1 SDIO adapter .....  | 435        |
| 18.3.2 SDIO AHB Interface.....                                   | 445        |
| 18.4 Card function description .....                             | 446        |
| 18.4.1 Confirmation of working voltage range .....               | 446        |
| 18.4.2 Card reset .....  | 446        |
| 18.4.3 Card identification mode .....                            | 447        |
| 18.4.4 Card identification process.....                          | 447        |
| 18.4.5 Write data block.....                                     | 448        |
| 18.4.6 Read data block.....                                      | 448        |
| 18.4.7 Data Streaming Operation (Only for Multimedia Card) ..... | 449        |
| 18.4.8 Erase.....  | 450        |
| 18.4.9 Wide bus selection and de-selection .....                 | 451        |
| 18.4.10 Protection management.....                               | 451        |
| 18.4.11 Card status register.....                                | 455        |
| 18.4.12 SD I/O mode.....   | 461        |
| 18.5 Commands and responses.....                                 | 462        |
| 18.5.1 Application related commands and general commands .....   | 462        |
| 18.5.2 Commands of Multimedia Card/SD Card module .....          | 463        |
| 18.5.3 Command type.....   | 466        |
| 18.5.4 Command format.....                                       | 466        |
| 18.5.5 Response format .....                                     | 467        |
| 18.6 Hardware flow control.....                                  | 470        |
| 18.7 SDIO register.....  | 470        |
| 18.7.1 SDIO register overview .....                              | 471        |
| 18.7.2 SDIO power control register (SDIO_PWRCTRL) .....          | 472        |
| 18.7.3 SDIO clock control register (SDIO_CLKCTRL) .....          | 472        |
| 18.7.4 SDIO command argument register (SDIO_CMDARG).....         | 473        |
| 18.7.5 SDIO command register (SDIO_CMDCTRL) .....                | 474        |
| 18.7.6 SDIO command response register(SDIO_CMDRESP).....         | 475        |
| 18.7.7 SDIO response 1..4 register (SDIO_RESPONSEx) .....        | 475        |
| 18.7.8 SDIO data timer register (SDIO_DTIMER).....               | 476        |
| 18.7.9 SDIO data length register (SDIO_DATLEN) .....             | 476        |
| 18.7.10 SDIO data control register (SDIO_DATCTRL).....           | 477        |
| 18.7.11 SDIO data counter register (SDIO_DATCOUNT).....          | 478        |
| 18.7.12 SDIO status register (SDIO_STS).....                     | 479        |

|  |            |
|--|------------|
| 18.7.13 SDIO interrupt clear register (SDIO_INTCLR) .....                        | 480        |
| 18.7.14 SDIO interrupt enable register (SDIO_INTEN) .....                        | 481        |
| 18.7.15 SDIO FIFO counter register (SDIO_FIFOCOUNT).....                         | 484        |
| 18.7.16 SDIO data FIFO register (SDIO_DATFIFO).....                              | 484        |
| <b>19 Universal serial bus full-speed device interface (USB_FS_Device) .....</b> | <b>486</b> |
| 19.1 Introduction .....  | 486        |
| 19.2 Main features .....   | 486        |
| 19.3 Clock configuration .....   | 487        |
| 19.4 Functional description .....  | 487        |
| 19.4.1 Access Packet Buffer Memory .....   | 487        |
| 19.4.2 Buffer description table .....  | 488        |
| 19.4.3 Double-buffered endpoints .....   | 489        |
| 19.4.4 USB transfer .....  | 492        |
| 19.4.5 USB events and interrupts .....   | 497        |
| 19.4.6 Endpoint initialization .....   | 499        |
| 19.5 USB registers .....   | 499        |
| 19.5.1 USB register overview .....   | 499        |
| 19.5.2 USB endpoint n register (USB_EPn), n=[0..7] .....                         | 500        |
| 19.5.3 USB control register (USB_CTRL).....                                      | 503        |
| 19.5.4 USB interrupt status register (USB_STS) .....                             | 505        |
| 19.5.5 USB frame number register (USB_FN) .....                                  | 507        |
| 19.5.6 USB device address register (USB_ADDR).....                               | 508        |
| 19.5.7 USB packet buffer description table address register (USB_BUFTAB) .....   | 508        |
| 19.6 Buffer description table .....  | 509        |
| 19.6.1 Send buffer address register n (USB_ADDRn_TX) .....                       | 509        |
| 19.6.2 Send data byte number register n (USB_CNTn_TX) .....                      | 509        |
| 19.6.3 Receive buffer address register n (USB_ADDRn_RX) .....                    | 510        |
| 19.6.4 Receive data byte number register n (USB_CNTn_RX) .....                   | 510        |
| <b>20 Controller area network (CAN).....</b>                                     | <b>512</b> |
| 20.1 Introduction to CAN .....   | 512        |
| 20.2 Main features of CAN .....  | 512        |
| 20.3 CAN overall introduction .....  | 513        |
| 20.3.1 CAN module .....  | 513        |
| 20.3.2 CAN working mode.....   | 513        |
| 20.3.3 Send mailbox .....  | 515        |
| 20.3.4 Receiving filter .....  | 515        |
| 20.3.5 Receive FIFO .....  | 515        |
| 20.3.6 CAN Test mode .....   | 517        |
| 20.3.7 CAN Debugging mode.....   | 519        |
| 20.4 CAN function description.....   | 519        |
| 20.4.1 Send processing .....   | 519        |
| 20.4.2 Time triggered communication mode .....                                   | 520        |
| 20.4.3 Non-automatic retransmission mode.....                                    | 520        |

|  |            |
|--|------------|
| 20.4.4 Receiving management .....  | 521        |
| 20.4.5 Identifier filtering .....  | 522        |
| 20.4.6 Message storage .....   | 525        |
| 20.4.7 Bit time characteristic .....   | 526        |
| 20.5 CAN interrupt .....   | 529        |
| 20.5.1 Error management .....  | 530        |
| 20.5.2 Bus-Off recovery .....  | 530        |
| 20.6 CAN Configuration Flow .....  | 530        |
| 20.7 CAN Register File .....   | 532        |
| 20.7.1 Register Description .....  | 532        |
| 20.7.2 CAN register address overview .....   | 532        |
| 20.7.3 CAN control and status register .....   | 536        |
| 20.7.4 CAN mailbox register .....  | 546        |
| 20.7.5 CAN filter register .....   | 551        |
| <b>21 Serial peripheral interface/Inter-IC Sound (SPI/ I<sup>2</sup>S) .....</b>           | <b>555</b> |
| 21.1 Introduction .....  | 555        |
| 21.2 Main features .....   | 555        |
| 21.2.1 SPI features .....  | 555        |
| 21.2.2 I <sup>2</sup> S features .....   | 555        |
| 21.3 SPI function description .....  | 556        |
| 21.3.1 General description .....   | 556        |
| 21.3.2 SPI work mode .....   | 559        |
| 21.3.3 Status flag .....   | 565        |
| 21.3.4 Disabling the SPI .....   | 566        |
| 21.3.5 SPI communication using DMA .....   | 567        |
| 21.3.6 CRC calculation .....   | 568        |
| 21.3.7 Error flag .....  | 568        |
| 21.3.8 SPI interrupt .....   | 569        |
| 21.4 I <sup>2</sup> S function description .....   | 570        |
| 21.4.1 Supported audio protocols .....   | 571        |
| 21.4.2 Clock generator .....   | 577        |
| 21.4.3 I <sup>2</sup> S Transmission and reception sequence .....                          | 579        |
| 21.4.4 Status flag .....   | 581        |
| 21.4.5 Error flag .....  | 582        |
| 21.4.6 I <sup>2</sup> S interrupt .....  | 582        |
| 21.4.7 DMA function .....  | 582        |
| 21.5 SPI and I <sup>2</sup> S register .....   | 583        |
| 21.5.1 SPI register overview .....   | 583        |
| 21.5.2 SPI control register 1 (SPI_CTRL1) (not used in I2S mode) .....                     | 583        |
| 21.5.3 SPI control register 2 (SPI_CTRL2) .....  | 585        |
| 21.5.4 SPI status register (SPI_STS) .....   | 586        |
| 21.5.5 SPI data register (SPI_DAT) .....   | 587        |
| 21.5.6 SPI CRC polynomial register (SPI_CRCPOLY) (not used in I <sup>2</sup> S mode) ..... | 588        |
| 21.5.7 SPI RX CRC register (SPI_CRCRDAT) (not used in I <sup>2</sup> S mode) .....         | 588        |

|   |            |
|---|------------|
| 21.5.8 SPI TX CRC register (SPI_CRCTDAT) .....                                  | 589        |
| 21.5.9 SPI_I <sup>2</sup> S configuration register (SPI_I2SCFG) .....           | 589        |
| 21.5.10 SPI_I <sup>2</sup> S prescaler register (SPI_I2SPREDIV) .....           | 591        |
| <b>22 I<sup>2</sup>C interface .....</b>  | <b>592</b> |
| 22.1 Introduction .....   | 592        |
| 22.2 Main features .....  | 592        |
| 22.3 Function description .....   | 592        |
| 22.3.1 SDA and SCL line control.....  | 592        |
| 22.3.2 Software communication process .....                                     | 593        |
| 22.3.3 Error conditions description.....  | 603        |
| 22.3.4 DMA application .....  | 604        |
| 22.3.5 Packet error check.....  | 605        |
| 22.3.6 SMBus.....   | 605        |
| 22.4 Debug mode.....  | 608        |
| 22.5 Interrupt request.....   | 608        |
| 22.6 I2C registers.....   | 608        |
| 22.6.1 I2C register overview .....  | 609        |
| 22.6.2 I2C Control register 1 (I2C_CTRL1).....                                  | 609        |
| 22.6.3 I2C Control register 2 (I2C_CTRL2).....                                  | 611        |
| 22.6.4 I2C Own address register 1 (I2C_OADDR1) .....                            | 613        |
| 22.6.5 I2C Own address register 2 (I2C_OADDR2) .....                            | 613        |
| 22.6.6 I2C Data register (I2C_DAT).....   | 614        |
| 22.6.7 I2C Status register 1 (I2C_STS1) .....                                   | 614        |
| 22.6.8 I2C Status register 2 (I2C_STS2) .....                                   | 617        |
| 22.6.9 I2C Clock control register (I2C_CLKCTRL).....                            | 618        |
| 22.6.10 I2C Rise time register (I2C_TMRISE).....                                | 619        |
| <b>23 Universal synchronous asynchronous receiver transmitter (USART) .....</b> | <b>621</b> |
| 23.1 Introduction .....   | 621        |
| 23.2 Main features .....  | 621        |
| 23.3 Functional block diagram .....   | 622        |
| 23.4 Function description .....   | 622        |
| 23.4.1 USART frame format .....   | 623        |
| 23.4.2 Transmitter .....  | 624        |
| 23.4.3 Receiver .....   | 627        |
| 23.4.4 Generation of fractional baud rate.....                                  | 630        |
| 23.4.5 Receiver's tolerance clock deviation .....                               | 631        |
| 23.4.6 Parity control.....  | 632        |
| 23.4.7 DMA application .....  | 633        |
| 23.4.8 Hardware flow control.....   | 634        |
| 23.4.9 Multiprocessor communication .....                                       | 636        |
| 23.4.10 Synchronous mode.....   | 638        |
| 23.4.11 Single-wire half-duplex mode .....                                      | 640        |
| 23.4.12 IrDA SIR ENDEC mode .....   | 641        |

|   |            |
|---|------------|
| 23.4.13 LIN mode.....   | 642        |
| 23.4.14 Smartcard mode (ISO7816).....   | 644        |
| 23.5 Interrupt request.....   | 646        |
| 23.6 Mode support.....  | 647        |
| 23.7 USART registers.....   | 647        |
| 23.7.1 USART register overview .....  | 647        |
| 23.7.2 USART Status register (USART_STS) .....                                      | 648        |
| 23.7.3 USART Data register (USART_DAT) .....  | 650        |
| 23.7.4 USART Baud rate register (USART_BRCF).....                                   | 650        |
| 23.7.5 USART control register 1 register (USART_CTRL1) .....                        | 651        |
| 23.7.6 USART control register 2 register (USART_CTRL2) .....                        | 653        |
| 23.7.7 USART control register 3 register (USART_CTRL3) .....                        | 654        |
| 23.7.8 USART guard time and prescaler register (USART_GTP).....                     | 655        |
| <b>24 Quad Serial Peripheral Interface (QSPI) .....</b>                             | <b>657</b> |
| 24.1 Introduction .....   | 657        |
| 24.2 QSPI Main features .....   | 657        |
| 24.3 Function description .....   | 658        |
| 24.4 QSPI command sequence .....  | 658        |
| 24.5 Operating procedures.....  | 659        |
| 24.5.1 QSPI indirect mode .....   | 659        |
| 24.5.2 QSPI Indirect send operation .....   | 660        |
| 24.5.3 QSPI indirect receive operation .....  | 661        |
| 24.6 QSPI register .....  | 664        |
| 24.6.1 QSPI register overview.....  | 664        |
| 24.6.2 QSPI Control 0 Register (QSPI_CTRL0) .....                                   | 666        |
| 24.6.3 QSPI Control 1 Register (QSPI_CTRL1) .....                                   | 668        |
| 24.6.4 QSPI Enable Register (QSPI_EN).....  | 668        |
| 24.6.5 QSPI Microwire Control Register (QSPI_MW_CTRL) .....                         | 669        |
| 24.6.6 QSPI Slave Enable Register (QSPI_SLAVE_EN).....                              | 669        |
| 24.6.7 QSPI Baud Rate Select Register (QSPI_BAUD) .....                             | 670        |
| 24.6.8 QSPI Transmit FIFO Threshold Level Register (QSPI_TXFT).....                 | 670        |
| 24.6.9 QSPI Receive FIFO Threshold Level Register (QSPI_RXFT) .....                 | 671        |
| 24.6.10 QSPI Transmit FIFO Level Register (QSPI_TXFN) .....                         | 671        |
| 24.6.11 QSPI Receive FIFO Level Register (QSPI_RXFN) .....                          | 671        |
| 24.6.12 QSPI Status Register (QSPI_STS).....  | 672        |
| 24.6.13 QSPI Interrupt Mask Register (QSPI_IMASK) .....                             | 673        |
| 24.6.14 QSPI Interrupt Status Register (QSPI_ISTS) .....                            | 674        |
| 24.6.15 QSPI Raw Interrupt Status Register (QSPI_RISTS).....                        | 674        |
| 24.6.16 QSPI Transmit FIFO Overflow Interrupt Clear Register (QSPI_TXFOI_CLR) ..... | 675        |
| 24.6.17 QSPI Receive FIFO Overflow Interrupt Clear Register (QSPI_RXFOI_CLR).....   | 676        |
| 24.6.18 QSPI Receive FIFO Underflow Interrupt Clear Register (QSPI_RXFUI_CLR) ..... | 676        |
| 24.6.19 QSPI Multi-Master Interrupt Clear Register (QSPI_MMCI_CLR) .....            | 676        |
| 24.6.20 QSPI Interrupt Clear Register (QSPI_ICLR).....                              | 677        |
| 24.6.21 QSPI DMA Control Register (QSPI_DMA_CTRL).....                              | 677        |

|           |  |            |
|-----------|--|------------|
| 24.6.22   | QSPI DMA Transmit Data Level Register (QSPI_DMATDL_CTRL)                     | 678        |
| 24.6.23   | QSPI DMA Receive Data Level Register (QSPI_DMARDL_CTRL)                      | 678        |
| 24.6.24   | QSPI Data Register (QSPI_DATx)   | 678        |
| 24.6.25   | QSPI RX Sample Delay Register (QSPI_RS_DELAY)                                | 679        |
| 24.6.26   | QSPI Enhanced SPI Mode Control 0 Register (QSPI_ENH_CTRL0)                   | 679        |
| 24.6.27   | QSPI DDR Transmit Drive Edge Register (QSPI_DDR_TXDE)                        | 681        |
| 24.6.28   | QSPI XIP Mode bits Register (QSPI_XIP_MODE)                                  | 681        |
| 24.6.29   | QSPI XIP INCR transfer opcode Register (QSPI_XIP_INCR_TOC)                   | 681        |
| 24.6.30   | QSPI XIP WRAP transfer opcode Register (QSPI_XIP_WRAP_TOC)                   | 682        |
| 24.6.31   | QSPI XIP Control Register (QSPI_XIP_CTRL)                                    | 682        |
| 24.6.32   | QSPI XIP Slave Enable Register (QSPI_XIP_SLAVE_EN)                           | 684        |
| 24.6.33   | QSPI XIP Receive FIFO Overflow Interrupt Clear Register (QSPI_XIP_RXFOI_CLR) | 684        |
| 24.6.34   | QSPI XIP time out for continuous transfers register (QSPI_XIP_TOUT)          | 685        |
| <b>25</b> | <b>Ethernet (ETH)</b>  | <b>686</b> |
| 25.1      | Introduction   | 686        |
| 25.2      | Main features  | 686        |
| 25.3      | Function block diagram   | 688        |
| 25.4      | Function description   | 688        |
| 25.4.1    | IEEE 802.3 ethernet frame format   | 688        |
| 25.4.2    | Pin configuration (alternate) method   | 689        |
| 25.4.3    | SMI interface  | 690        |
| 25.4.4    | MII interface  | 691        |
| 25.4.5    | RMII interface   | 693        |
| 25.4.6    | MAC function description   | 694        |
| 25.4.7    | Power management (PMT)   | 703        |
| 25.4.8    | Ethernet DMA function description  | 706        |
| 25.4.9    | Precision time protocol (PTP)  | 721        |
| 25.4.10   | Typical ethernet configuration flow example                                  | 724        |
| 25.4.11   | Ethernet interrupt   | 725        |
| 25.5      | ETH register   | 726        |
| 25.5.1    | ETH register overview  | 726        |
| 25.5.2    | ETH MAC configuration register (ETH_MACCFG)                                  | 729        |
| 25.5.3    | ETH MAC frame filter register (ETH_MACFFLT)                                  | 731        |
| 25.5.4    | ETH MAC HASH list high register (ETH_MACHASHHI)                              | 733        |
| 25.5.5    | ETH MAC HASH list low register (ETH_MACHASHLO)                               | 733        |
| 25.5.6    | ETH MAC MII address register (ETH_MACMIIADDR)                                | 734        |
| 25.5.7    | ETH MAC MII data register (ETH_MACMIIDAT)                                    | 735        |
| 25.5.8    | ETH MAC flow control register (ETH_MACFLWCTRL)                               | 735        |
| 25.5.9    | ETH MAC VLAN tag register (ETH_MACVLANTAG)                                   | 737        |
| 25.5.10   | ETH MAC remote wakeup frame filter register (ETH_MACRTWUFRMFLT)              | 738        |
| 25.5.11   | ETH MAC PMT control and status register (ETH_MACPMTCTRLSTS)                  | 738        |
| 25.5.12   | ETH MAC interrupt status register (ETH_MACINTSTS)                            | 739        |
| 25.5.13   | ETH MAC interrupt mask register (ETH_MACINTMSK)                              | 740        |
| 25.5.14   | ETH MAC address 0 high register (ETH_MACADDR0HI)                             | 740        |

|   |            |
|---|------------|
| 25.5.15 ETH MAC address 0 low register (ETH_MACADDR0LO).....  | 741        |
| 25.5.16 ETH MAC address 1 high register (ETH_MACADDR1HI) .....  | 741        |
| 25.5.17 ETH MAC address 1 low register (ETH_MACADDR1LO).....  | 742        |
| 25.5.18 ETH MAC address 2 high register (ETH_MACADDR2HI) .....  | 742        |
| 25.5.19 ETH MAC address 2 low register (ETH_MACADDR2LO).....  | 743        |
| 25.5.20 ETH MAC address 3 high register (ETH_MACADDR3HI) .....  | 744        |
| 25.5.21 ETH MAC address 3 low register (ETH_MACADDR3LO).....  | 744        |
| 25.5.22 ETH MMC control register (ETH_MMCTRL).....  | 745        |
| 25.5.23 ETH MMC receive interrupt status register (ETH_MMCRXINT) .....  | 745        |
| 25.5.24 ETH MMC transmit interrupt status register (ETH_MMCTXINT) .....   | 746        |
| 25.5.25 ETH MMC receive interrupt mask register (ETH_MMCRXINTMSK) .....   | 747        |
| 25.5.26 ETH MMC transmit interrupt mask register (ETH_MMCTXINTMSK) .....  | 748        |
| 25.5.27 ETH MMC transmitted "good" frame counter register after 1 collision (ETH_MMCTXGFASCCNT).....                | 748        |
| 25.5.28 ETH MMC transmitted "good" frame counter register after more than 1 collision<br>(ETH_MMCTXGFAMSCCNT) ..... | 749        |
| 25.5.29 ETH MMC transmitted "good" frame counter register (ETH_MMCTXGFCNT) .....                                    | 749        |
| 25.5.30 ETH MMC CRC error received frame counter register (ETH_MMCRXFCECNT) .....                                   | 750        |
| 25.5.31 ETH MMC alignment error received frame counter register (ETH_MMCRXFAECNT).....                              | 750        |
| 25.5.32 ETH MMC receive "good" unicast frame counter register (ETH_MMCRXGUFECNT).....                               | 750        |
| 25.5.33 ETH PTP timestamp control register (ETH_PTPTSCTRL).....   | 751        |
| 25.5.34 ETH PTP subsecond increment register (ETH_PTPSSINC) .....   | 752        |
| 25.5.35 ETH PTP timestamp high register (ETH_PTPSEC).....   | 752        |
| 25.5.36 ETH PTP timestamp low register (ETH_PTPNS) .....  | 753        |
| 25.5.37 ETH PTP timestamp high update register (ETH_PTPSECUP).....  | 753        |
| 25.5.38 ETH PTP timestamp low update register (ETH_PTPNSUP) .....   | 754        |
| 25.5.39 ETH PTP timestamp addend register (ETH_PTPTSADD).....   | 754        |
| 25.5.40 ETH PTP target time high register (ETH_PTPTTSEC) .....  | 755        |
| 25.5.41 ETH PTP target time low register (ETH_PTPTTNS) .....  | 755        |
| 25.5.42 ETH DMA bus mode register (ETH_DMABUSMOD).....  | 756        |
| 25.5.43 ETH DMA transmit query request register (ETH_DMATXPD) .....   | 758        |
| 25.5.44 ETH DMA receive query request register (ETH_DMARXPD) .....  | 758        |
| 25.5.45 ETH DMA receive descriptor list address register (ETH_DMARXDLADDR).....                                     | 759        |
| 25.5.46 ETH DMA transmit descriptor list address register (ETH_DMATXDLADDR) .....                                   | 759        |
| 25.5.47 ETH DMA status register (ETH_DMASTS).....   | 760        |
| 25.5.48 ETH DMA operation mode register (ETH_DMAOPMOD).....   | 763        |
| 25.5.49 ETH DMA interrupt enable register (ETH_DMAMATEN) .....  | 766        |
| 25.5.50 ETH DMA missed frames and buffer overflow counter register (ETH_DMAMFBOCNT) .....                           | 768        |
| 25.5.51 ETH DMA current transmit descriptor address register (ETH_DMACHTXDESC).....                                 | 768        |
| 25.5.52 ETH DMA current receive descriptor address register (ETH_DMACHRXDESC) .....                                 | 769        |
| 25.5.53 ETH DMA current transmit buffer address register (ETH_DMACHTXBADDR) .....                                   | 769        |
| 25.5.54 ETH DMA current receive buffer address register (ETH_DMACHRXBADDR) .....                                    | 770        |
| <b>26 Comparator (COMP) .....</b>   | <b>771</b> |
| 26.1 COMP system connection block diagram.....  | 771        |
| 26.2 Main features .....  | 774        |

|  |            |
|--|------------|
| 26.3 COMP configuration process.....                             | 774        |
| 26.4 COMP working mode.....                                      | 775        |
| 26.4.1 Window mode .....   | 775        |
| 26.4.2 Independent comparator.....                               | 775        |
| 26.5 Comparator interconnection .....                            | 775        |
| 26.6 Interrupt .....   | 776        |
| 26.7 COMP register .....   | 777        |
| 26.7.1 COMP register overview .....                              | 777        |
| 26.7.2 COMP control register (COMPx_CTRL) .....                  | 779        |
| 26.7.3 COMP window mode register (COMP_WINMODE) .....            | 780        |
| 26.7.4 COMP lock register (COMP_LOCK).....                       | 781        |
| 26.7.5 COMP interrupt enable register (COMP_INTEN).....          | 781        |
| 26.7.6 COMP interrupt status register (COMP_INTSTS).....         | 782        |
| 26.7.7 COMP filter register (COMPx_FILC).....                    | 782        |
| 26.7.8 COMP filter frequency division register (COMPx_FILP)..... | 783        |
| 26.7.9 COMP reference voltage register (COMP_VREFSCL).....       | 783        |
| <b>27 Operational Amplifier (OPAMP).....</b>                     | <b>785</b> |
| 27.1 Main features .....   | 785        |
| 27.1.1 OPAMP function description .....                          | 785        |
| 27.1.2 Internal connection between OPAMP and COMP.....           | 787        |
| 27.2 OPAMP working mode.....                                     | 790        |
| 27.2.1 OPAMP independent op amp mode .....                       | 790        |
| 27.2.2 OPAMP follow mode .....                                   | 790        |
| 27.2.3 OPAMP internal gain (PGA) mode .....                      | 791        |
| 27.2.4 OPAMP with filter internal gain mode .....                | 792        |
| 27.2.5 OPAMP independent write protection .....                  | 793        |
| 27.2.6 OPAMP TIMER controls the switching mode.....              | 793        |
| 27.3 OPAMP register .....  | 793        |
| 27.3.1 OPAMP register overview .....                             | 793        |
| 27.3.2 OPAMP Control Status Register (OPAMPx_CS).....            | 794        |
| 27.3.3 OPAMP Lock register (OPAMP_LOCK) .....                    | 796        |
| <b>28 DVP interface (DVP) .....</b>                              | <b>797</b> |
| 28.1 Introduction .....  | 797        |
| 28.2 Hardware Interface .....                                    | 797        |
| 28.2.1 Pin multiplexing mode.....                                | 797        |
| 28.2.2 Interface Timing.....                                     | 798        |
| 28.3 Operating Instructions .....                                | 798        |
| 28.3.1 General operation process .....                           | 798        |
| 28.3.2 DMA application .....                                     | 799        |
| 28.3.3 Image size.....   | 799        |
| 28.3.4 Image area.....   | 799        |
| 28.3.5 Image scaling .....                                       | 799        |
| 28.3.6 Soft reset.....   | 799        |

|  |            |
|--|------------|
| 28.3.7 Interrupts .....  | 800        |
| 28.3.8 Read FIFO data.....                                       | 800        |
| 28.3.9 Notes.....  | 800        |
| <b>28.4 DVP register .....</b>                                   | <b>801</b> |
| 28.4.1 DVP register overview.....                                | 801        |
| 28.4.2 DVP Control Register (DVP_CTRL) .....                     | 801        |
| 28.4.3 DVP Status Register (DVP_STS) .....                       | 803        |
| 28.4.4 DVP Interrupt Status Register (DVP_INTSTS) .....          | 803        |
| 28.4.5 DVP Interrupt Enable Register .....                       | 805        |
| 28.4.6 DVP interrupt trigger status register (DVP_MINTSTS) ..... | 806        |
| 28.4.7 DVP image start register (DVP_WST) .....                  | 807        |
| 28.4.8 DVP image size register (DVP_WSIZE) .....                 | 808        |
| 28.4.9 DVP FIFO register (DVP_FIFO) .....                        | 808        |
| <b>29 Debug support (DBG).....</b>                               | <b>809</b> |
| 29.1 Overview .....  | 809        |
| 29.2 JTAG/SWD function .....                                     | 810        |
| 29.2.1 Switch JTAG/SWD interface .....                           | 810        |
| 29.2.2 Pin allocation .....                                      | 810        |
| 29.3 MCU debugging function.....                                 | 811        |
| 29.3.1 Low power mode support .....                              | 811        |
| 29.3.2 Peripheral debugging support.....                         | 811        |
| 29.4 DBG registers .....   | 812        |
| 29.4.1 DBG register overview .....                               | 812        |
| 29.4.2 ID register (DBG_ID).....                                 | 812        |
| 29.4.3 Debug control register (DBG_CTRL) .....                   | 813        |
| <b>30 Unique device serial number (UID).....</b>                 | <b>815</b> |
| 30.1 Introduction .....  | 815        |
| 30.2 UID register .....  | 815        |
| 30.3 UCID register .....   | 815        |
| <b>31 Version history .....</b>                                  | <b>816</b> |
| <b>32 Notice .....</b>   | <b>818</b> |

## List of Table

|  |     |
|--|-----|
| Table 2-1 Vector table .....   | 36  |
| Table 2-2 EXTI register review .....   | 43  |
| Table 3-1 List of boot mode.....   | 51  |
| Table 3-2 Flash bus address list .....   | 52  |
| Table 3-3 Option byte list .....   | 56  |
| Table 3-4 Read protection configuration list .....                                       | 57  |
| Table 3-5 Flash read-write-erase <sup>(1)</sup> permission control table .....           | 58  |
| Table 3-6 SRAM Capacity Configuration Table.....   | 65  |
| Table 3-7 FLASH register overview.....   | 65  |
| Table 4-1 Power modes.....   | 78  |
| Table 4-2 Blocks running state <sup>(1)</sup> .....                                      | 80  |
| Table 4-3 PWR register overview.....   | 86  |
| Table 5-1 BKP Register overview .....  | 92  |
| Table 6-1 RCC register overview .....  | 104 |
| Table 7-1 I/O mode and configuration relationship .....                                  | 132 |
| Table 7-2 I/O characteristics of different I/O configurations.....                       | 133 |
| Table 7-3 Debug port image .....   | 141 |
| Table 7-4 ADC1 external trigger injection conversion alternate function remapping .....  | 142 |
| Table 7-5 ADC1 external trigger regular conversion alternate function remapping.....     | 142 |
| Table 7-6 ADC2 external trigger injection conversion alternate function remapping .....  | 142 |
| Table 7-7 ADC2 external trigger regular conversion alternate function remapping.....     | 142 |
| Table 7-8 ADC3 external trigger injection conversion alternate function remapping .....  | 142 |
| Table 7-9 ADC3 external trigger regular conversion alternate function remapping.....     | 143 |
| Table 7-10 ADC4 external trigger injection conversion alternate function remapping ..... | 143 |
| Table 7-11 ADC4 external trigger regular conversion alternate function remapping .....   | 143 |
| Table 7-12 TIM5 alternate function remapping .....                                       | 143 |
| Table 7-13 TIM4 alternate function remapping.....  | 143 |
| Table 7-14 TIM3 alternate function remapping.....  | 143 |
| Table 7-15 TIM2 alternate function remapping.....  | 143 |
| Table 7-16 TIM1 alternate function remapping.....  | 144 |

|  |     |
|--|-----|
| Table 7-17 TIM8 alternate function remapping .....   | 144 |
| Table 7-18 CAN1 alternate function remapping.....    | 144 |
| Table 7-19 CAN2 alternate function remapping.....    | 145 |
| Table 7-20 DVP alternate function remapping .....    | 145 |
| Table 7-21 USART1 alternate function remapping ..... | 145 |
| Table 7-22 USART2 alternate function remapping ..... | 145 |
| Table 7-23 USART3 alternate function remapping ..... | 146 |
| Table 7-24 UART4 alternate function remapping.....   | 146 |
| Table 7-25 UART5 alternate function remapping.....   | 146 |
| Table 7-26 UART6 alternate function remapping.....   | 146 |
| Table 7-27 UART7 alternate function remapping.....   | 146 |
| Table 7-28 I2C1 pin remapping .....                  | 147 |
| Table 7-29 I2C2 pin remapping.....                   | 147 |
| Table 7-30 I2C3 pin remapping.....                   | 147 |
| Table 7-31 I2C4 pin remapping .....                  | 147 |
| Table 7-32 SPI1 pin remapping .....                  | 147 |
| Table 7-33 SPI2/I2S2 pin remapping.....              | 148 |
| Table 7-34 SPI3/I2S3 pin remapping.....              | 148 |
| Table 7-35 SDIO pin remapping.....                   | 148 |
| Table 7-36 QSPI pin remapping .....                  | 148 |
| Table 7-37 ETH pin remapping .....                   | 149 |
| Table 7-38 ADC/DAC .....                             | 149 |
| Table 7-39 TIM1/TIM8 .....                           | 150 |
| Table 7-40 TIM2/3/4/5.....                           | 150 |
| Table 7-41 bxCAN.....                                | 150 |
| Table 7-42 DVP .....                                 | 150 |
| Table 7-43 USART .....                               | 151 |
| Table 7-44 I2C .....                                 | 151 |
| Table 7-45 SPI .....                                 | 151 |
| Table 7-46 I2S.....                                  | 152 |
| Table 7-47 SDIO.....                                 | 152 |
| Table 7-48 QSPI .....                                | 152 |

|   |     |
|---|-----|
| Table 7-49 ETH .....  | 153 |
| Table 7-50 USB .....  | 154 |
| Table 7-51 Other .....  | 154 |
| Table 7-52 GPIO registers overview.....   | 156 |
| Table 7-53 AFIO register overview .....   | 162 |
| Table 8-1 Programmable data width and endian operation (when PINC = MINC = 1) .....             | 180 |
| Table 8-2 Flow control table .....  | 183 |
| Table 8-3 DMA interrupt request.....  | 184 |
| Table 8-4 DMA1 request mapping table for each channel .....                                     | 185 |
| Table 8-5 DMA2 request mapping table for each channel .....                                     | 187 |
| Table 8-6 DMA register overview .....   | 188 |
| Table 9-1 ADC pins .....  | 200 |
| Table 9-2 Analog watchdog channel selection.....  | 206 |
| Table 9-3 Right-align data .....  | 209 |
| Table 9-4 Left-align data.....  | 210 |
| Table 9-5 External trigger for regular channels of ADC1 and ADC2.....                           | 211 |
| Table 9-6 External trigger for regular channels of ADC3 and ADC4.....                           | 211 |
| Table 9-7 External trigger for injection channel of ADC1 and ADC2.....                          | 212 |
| Table 9-8 External trigger for injection channel of ADC3 and ADC4.....                          | 212 |
| Table 9-9 ADC interrupt .....   | 222 |
| Table 9-10 ADC register overview .....  | 222 |
| Table 10-1 DAC pins .....   | 239 |
| Table 10-2 DAC external trigger .....   | 242 |
| Table 10-3 DAC registers overvie .....  | 251 |
| Table 11-1 Counting direction versus encoder signals .....                                      | 293 |
| Table 11-2 Register map and reset value .....   | 298 |
| Table 11-3 TIMx internal trigger connection.....  | 305 |
| Table 11-4 Output control bits of complementary OCx and OCxN channels with break function ..... | 317 |
| Table 12-1 Counting direction versus encoder signals .....                                      | 354 |
| Table 12-2 Register map and reset value .....   | 356 |
| Table 12-3 TIMx internal trigger connection.....  | 363 |
| Table 12-4 Output control bits of standard OCx channel .....                                    | 373 |

|   |     |
|---|-----|
| Table 13-1 Register overview .....                            | 384 |
| Table 14-1 RTC feature support.....                           | 390 |
| Table 14-2 RTC register overview .....                        | 398 |
| Table 15-1 CRC register overview .....                        | 416 |
| Table 16-1 IWDG counting maximum and minimum reset time ..... | 423 |
| Table 16-2 IWDG register overview.....                        | 424 |
| Table 17-1 Maximum and minimum counting time of WWDG.....     | 429 |
| Table 17-2 WWDG register overview .....                       | 430 |
| Table 18-1 MMC/SD/SD I/O Card bus pin definition.....         | 436 |
| Table 18-2 Command Channel Status Flags.....                  | 440 |
| Table 18-3 Data Token Format .....                            | 443 |
| Table 18-4 Transmit FIFO Status Flags.....                    | 444 |
| Table 18-5 Receive FIFO Status Flags .....                    | 444 |
| Table 18-6 Lock/Unlock Data Structure .....                   | 452 |
| Table 18-7 Card Status.....                                   | 455 |
| Table 18-8 SD Status .....                                    | 458 |
| Table 18-9 Speed Type Codes.....                              | 459 |
| Table 18-10 Mobility Performance Codes.....                   | 460 |
| Table 18-11 AU_SIZE Codes .....                               | 460 |
| Table 18-12 Maximum AU Size .....                             | 460 |
| Table 18-13 ERASE_SIZE Codes .....                            | 461 |
| Table 18-14 Erase Timeout Code.....                           | 461 |
| Table 18-15 Erase Offset Codes .....                          | 461 |
| Table 18-16 Write commands for block-based transfers .....    | 463 |
| Table 18-17 Block-based write-protect commands .....          | 464 |
| Table 18-18 Erase command.....                                | 465 |
| Table 18-19 I/O mode command .....                            | 465 |
| Table 18-20 Lock command .....                                | 465 |
| Table 18-21 Application related commands .....                | 465 |
| Table 18-22 Command format.....                               | 466 |
| Table 18-23 Short response format.....                        | 467 |
| Table 18-24 Long response format .....                        | 467 |

|   |     |
|---|-----|
| Table 18-25 R1 response.....  | 468 |
| Table 18-26 R2 response.....  | 468 |
| Table 18-27 R3 response.....  | 468 |
| Table 18-28 R4 response.....  | 469 |
| Table 18-29 R4b response.....   | 469 |
| Table 18-30 R5 response.....  | 469 |
| Table 18-31 R6 response.....  | 470 |
| Table 18-32 SDIO register overview .....  | 471 |
| Table 18-33 Response Type and SDIO_RESPONSEx Register.....                      | 476 |
| Table 19-1 DATTOG and SW_BUF definitions.....                                   | 490 |
| Table 19-2 How to use double buffering .....                                    | 490 |
| Table 19-3 How to use isochronous double buffering.....                         | 497 |
| Table 19-4 Resume event detection .....   | 498 |
| Table 19-5 USB register overview.....   | 499 |
| Table 19-6 Receive status code.....   | 503 |
| Table 19-7 Send status code.....  | 503 |
| Table 19-8 Endpoint packet receive buffer size definition .....                 | 511 |
| Table 20-1 Examples of filter numbers.....                                      | 524 |
| Table 20-2 Send mailbox register list .....                                     | 526 |
| Table 20-3 Receive mailbox register list .....                                  | 526 |
| Table 20-4 CAN register overview .....  | 532 |
| Table 21-1 SPI interrupt request .....  | 569 |
| Table 21-2 Use the standard 8MHz HSE clock to get accurate audio frequency..... | 579 |
| Table 21-3 I <sup>2</sup> S interrupt request.....                              | 582 |
| Table 21-4 SPI register overview.....   | 583 |
| Table 22-1 Comparison between SMBus and I <sup>2</sup> C.....                   | 606 |
| Table 22-2 I <sup>2</sup> C interrupt request.....                              | 608 |
| Table 22-3 I <sup>2</sup> C register overview .....                             | 609 |
| Table 23-1 Stop bit configuration .....   | 624 |
| Table 23-2 Data sampling for noise detection .....                              | 630 |
| Table 23-3 Error calculation when setting baud rate .....                       | 631 |
| Table 23-4 when DIV_Decimal = 0. Tolerance of USART receiver .....              | 632 |

|   |     |
|---|-----|
| Table 23-5 when DIV_Decimal != 0. Tolerance of USART receiver ..... | 632 |
| Table 23-6 Frame format .....                                       | 632 |
| Table 23-7 USART interrupt request.....                             | 646 |
| Table 23-8 USART mode setting <sup>(1)</sup> .....                  | 647 |
| Table 23-9 USART register overview.....                             | 647 |
| Table 24-1 QSPI register overview .....                             | 664 |
| Table 25-1 ETH module pin configuration (alternate).....            | 689 |
| Table 25-2 SMI clock configuration range .....                      | 691 |
| Table 25-3 Transmit interface signal code.....                      | 693 |
| Table 25-4 Receive interface signal code .....                      | 693 |
| Table 25-5 Destination address filter result list .....             | 700 |
| Table 25-6 Source address filter result list.....                   | 700 |
| Table 25-7 Remote wakeup frame filter register overview.....        | 704 |
| Table 25-8 Transmit descriptor overview .....                       | 708 |
| Table 25-9 Receive descriptor overview.....                         | 715 |
| Table 25-10 ETH register overview.....                              | 726 |
| Table 26-1 COMP register overview .....                             | 777 |
| Table 27-1 OPAMP register overview .....                            | 793 |
| Table 28-1 DVP pin multiplexing.....                                | 797 |
| Table 28-2 DVP register overview.....                               | 801 |
| Table 29-1 Debug port pin.....                                      | 810 |
| Table 29-2 DBG register overview .....                              | 812 |

## List of Figure

|  |     |
|--|-----|
| Figure 2-1 External interrupt/event controller block diagram .....                                       | 40  |
| Figure 2-2 External interrupt GPIO mapping .....   | 42  |
| Figure 3-1 Bus architecture .....  | 47  |
| Figure 3-2 Bus address map .....   | 49  |
| Figure 4-1 Power supply block diagram.....   | 76  |
| Figure 4-2 Waveforms of power-on reset and power-down reset.....   | 77  |
| Figure 4-3 PVD threshold waveform.....   | 78  |
| Figure 6-1 System reset generation .....   | 98  |
| Figure 6-2 Clock Tree.....   | 100 |
| Figure 6-3 HSE/LSE clock source.....   | 101 |
| Figure 7-1 Basic structure of I/O port.....  | 132 |
| Figure 7-2 Input float/pull-up/pull-down configuration .....   | 134 |
| Figure 7-3 Output mode configuration .....   | 135 |
| Figure 7-4 Alternate function configuration .....  | 136 |
| Figure 7-5 High impedance analog mode configuration .....  | 137 |
| Figure 8-1 DMA block diagram.....  | 179 |
| Figure 8-2 DMA1 request mapping.....   | 185 |
| Figure 8-3 DMA2 request mapping.....   | 187 |
| Figure 9-1 Block diagram of a single ADC .....   | 199 |
| Figure 9-2 ADC clock.....  | 201 |
| Figure 9-3 ADC1 and ADC2 channel pin connections .....   | 203 |
| Figure 9-4 ADC3 and ADC4 channel pin connections.....  | 204 |
| Figure 9-5 Timing diagram.....   | 206 |
| Figure 9-6 Injection conversion delay .....  | 208 |
| Figure 9-7 Calibration sequence diagram.....   | 209 |
| Figure 9-8 Dual ADC Block Diagram .....  | 213 |
| Figure 9-9 Schematic diagram of synchronous regular mode conversion of 16 channels.....                  | 214 |
| Figure 9-10 Schematic diagram of synchronous injection mode conversion of 4 channels .....               | 215 |
| Figure 9-11 Schematic diagram of fast alternate mode conversion for continuous conversion of 1 channel.. | 216 |
| Figure 9-12 Schematic diagram of slow <i>alternate</i> mode conversion for 1 channel .....               | 217 |

|   |     |
|---|-----|
| Figure 9-13 Rotation triggering: injecting channel groups.....  | 217 |
| Figure 9-14 Rotation trigger: inject channel group in discontinuous mode.....                                     | 218 |
| Figure 9-15 Combination of rotation mode and synchronous regular mode .....                                       | 219 |
| Figure 9-16 Injection trigger occurs during injection transition .....  | 219 |
| Figure 9-17 Alternate single-channel conversions are interrupted by injection sequences CH3 and CH4.....          | 220 |
| Figure 9-18 Temperature sensor and VREFINT diagram of the channel .....   | 221 |
| Figure 10-1 Block diagram of a DAC channel .....  | 239 |
| Figure 10-2 Data format when DAC independent output.....  | 241 |
| Figure 10-3 Data format for DAC sync output.....  | 242 |
| Figure 10-4 Time diagram of transitions with trigger disabled .....   | 243 |
| Figure 10-5 LFSR algorithm for DAC .....  | 244 |
| Figure 10-6 DAC conversion with LFSR waveform generation (enable software trigger).....                           | 245 |
| Figure 10-7 Triangle wave generation of DAC .....   | 245 |
| Figure 10-8 DAC conversion with trigonometry generation (enable software trigger).....                            | 246 |
| Figure 11-1 Block diagram of TIM1 and TIM8.....   | 261 |
| Figure 11-2 Counter timing diagram with prescaler division change from 1 to 4.....                                | 262 |
| Figure 11-3 Timing diagram of up-counting. The internal clock divider factor = $2/N$ .....                        | 263 |
| Figure 11-4 Timing diagram of the up-counting, update event when ARPEN=0/1.....                                   | 264 |
| Figure 11-5 Timing diagram of the down-counting, internal clock divided factor = $2/N$ .....                      | 265 |
| Figure 11-6 Timing diagram of the Center-aligned, internal clock divided factor = $2/N$ .....                     | 266 |
| Figure 11-7 A center-aligned sequence diagram that includes counter overflows and underflows (ARPEN = 1)<br>..... | 266 |
| Figure 11-8 Repeat count sequence diagram in down-counting mode .....   | 268 |
| Figure 11-9 Repeat count sequence diagram in up-counting mode .....   | 269 |
| Figure 11-10 Repeat count sequence diagram in center-aligned mode.....  | 269 |
| Figure 11-11 Control circuit in normal mode, internal clock divided by 1.....                                     | 270 |
| Figure 11-12 TI2 external clock connection example.....   | 271 |
| Figure 11-13 Control circuit in external clock mode 1 .....   | 272 |
| Figure 11-14 External trigger input block diagram .....   | 272 |
| Figure 11-15 Control circuit in external clock mode 2.....  | 273 |
| Figure 11-16 Capture/compare channel (example: channel 1 input stage).....  | 274 |
| Figure 11-17 Capture/compare channel 1 main circuit.....  | 275 |

|   |     |
|---|-----|
| Figure 11-18 Output part of channelx (x= 1,2,3, take channel 1 as example) .....                                  | 276 |
| Figure 11-19 Output part of channelx (x= 4).....  | 276 |
| Figure 11-20 PWM input mode timing.....   | 278 |
| Figure 11-21 Output compare mode, toggle on OC1.....  | 280 |
| Figure 11-22 Center-aligned PWM waveform (AR=8).....  | 281 |
| Figure 11-23 Edge-aligned PWM waveform (APR=8).....   | 282 |
| Figure 11-24 Clearing the OCxREF of TIMx.....   | 285 |
| Figure 11-25 Complementary output with dead-time insertion.....   | 286 |
| Figure 11-26 Output behavior in response to a break.....  | 288 |
| Figure 11-27 Control circuit in reset mode.....   | 289 |
| Figure 11-28 Control circuit in Trigger mode.....   | 290 |
| Figure 11-29 Control circuit in Gated mode.....   | 291 |
| Figure 11-30 Control circuit in Trigger Mode + External Clock Mode2.....  | 292 |
| Figure 11-31 6-step PWM generation, COM example (OSSR=1) .....  | 293 |
| Figure 11-32 Example of counter operation in encoder interface mode.....  | 294 |
| Figure 11-33 Encoder interface mode example with IC1FP1 polarity inverted .....                                   | 295 |
| Figure 11-34 Example of Hall sensor interface .....   | 297 |
| Figure 12-1 Block diagram of TIMx (x=2, 3 ,4 and 5) .....   | 328 |
| Figure 12-2 Counter timing diagram with prescaler division change from 1 to 4.....                                | 329 |
| Figure 12-3 Timing diagram of up-counting. The internal clock divider factor = 2/N.....                           | 330 |
| Figure 12-4 Timing diagram of the up-counting, update event when ARPEN=0/1.....                                   | 331 |
| Figure 12-5 Timing diagram of the down-counting, internal clock divided factor = 2/N.....                         | 332 |
| Figure 12-6 Timing diagram of the Center-aligned, internal clock divided factor =2/N.....                         | 333 |
| Figure 12-7 A center-aligned sequence diagram that includes counter overflows and underflows (ARPEN = 1)<br>..... | 334 |
| Figure 12-8 Control circuit in normal mode, internal clock divided by 1 .....                                     | 335 |
| Figure 12-9 TI2 external clock connection example .....   | 336 |
| Figure 12-10 Control circuit in external clock mode 1 .....   | 337 |
| Figure 12-11 External trigger input block diagram .....   | 337 |
| Figure 12-12 Control circuit in external clock mode 2.....  | 338 |
| Figure 12-13 Capture/compare channel (example: channel 1 input stage).....  | 339 |
| Figure 12-14 Capture/compare channel 1 main circuit.....  | 340 |

|  |     |
|--|-----|
| Figure 12-15 Output part of channelx (x = 1,2,3,4;take channel 4 as an example)    | 341 |
| Figure 12-16 PWM input mode timing   | 343 |
| Figure 12-17 Output compare mode, toggle on OC1                                    | 345 |
| Figure 12-18 Center-aligned PWM waveform (AR=8)                                    | 346 |
| Figure 12-19 Edge-aligned PWM waveform (APR=8)                                     | 347 |
| Figure 12-20 Example of One-pulse mode   | 348 |
| Figure 12-21 Control circuit in reset mode   | 349 |
| Figure 12-22 Block diagram of timer interconnection                                | 350 |
| Figure 12-23 TIM2 gated by OC1REF of TIM1  | 351 |
| Figure 12-24 TIM2 gated by enable signal of TIM1                                   | 352 |
| Figure 12-25 Trigger TIM2 with an update of TIM1                                   | 353 |
| Figure 12-26 Triggers timers 1 and 2 using the TI1 input of TIM1                   | 354 |
| Figure 12-27 Example of counter operation in encoder interface mode                | 355 |
| Figure 12-28 Encoder interface mode example with IC1FP1 polarity inverted          | 356 |
| Figure 13-1 Block diagram of TIMx (x = 6 and 7)                                    | 379 |
| Figure 13-2 Counter timing diagram with prescaler division change from 1 to 4      | 380 |
| Figure 13-3 Timing diagram of up-counting. The internal clock divider factor = 2/N | 381 |
| Figure 13-4 Timing diagram of the up-counting, update event when ARPEN=0/1         | 382 |
| Figure 13-5 Control circuit in normal mode, internal clock divided by 1            | 383 |
| Figure 14-1 RTC Block Diagram  | 391 |
| Figure 15-1 CRC calculation unit block diagram                                     | 415 |
| Figure 16-1 Functional block diagram of the independent watchdog module            | 421 |
| Figure 17-1 Watchdog block diagram   | 427 |
| Figure 17-2 Refresh window and interrupt timing of WWDG                            | 428 |
| Figure 18-1 SDIO "No Response" and "No Data" operations                            | 433 |
| Figure 18-2 SDIO (multi) data block read operation                                 | 434 |
| Figure 18-3 SDIO (multiple) data block write operation                             | 434 |
| Figure 18-4 SDIO continuous read operation   | 434 |
| Figure 18-5 SDIO continuous write operation  | 434 |
| Figure 18-6 SDIO block diagram   | 435 |
| Figure 18-7 SDIO adapter   | 435 |
| Figure 18-8 Control unit   | 437 |

|  |     |
|--|-----|
| Figure 18-9 SDIO adapter command unit.....   | 438 |
| Figure 18-10 Command Path State Machine (CPSM).....  | 438 |
| Figure 18-11 SDIO command transmission.....  | 440 |
| Figure 18-12 Data Channel.....   | 441 |
| Figure 18-13 Data Path State Machine (DPSM).....   | 442 |
| Figure 19-1 USB device block diagram .....   | 486 |
| Figure 19-2 The user applications on the microcontrollers and the USB modules access Packet Buffer Memory .....                | 488 |
| Figure 19-3 The relationship between the buffer description table and the endpoint packet buffer.....                          | 489 |
| Figure 19-4 Double buffered bulk endpoint example.....   | 492 |
| Figure 19-5 Control transfer .....   | 496 |
| Figure 20-1 Topology of CAN network.....   | 513 |
| Figure 20-2 CAN working mode.....  | 515 |
| Figure 20-3 Dual CAN block diagram .....   | 516 |
| Figure 20-4 loopback mode .....  | 517 |
| Figure 20-5 silent mode .....  | 518 |
| Figure 20-6 loopback silent mode .....   | 518 |
| Figure 20-7 Send mailbox status .....  | 520 |
| Figure 20-8 Receive FIFO status .....  | 521 |
| Figure 20-9 Filter bit width setting-register organization.....  | 523 |
| Figure 20-10 Examples of filter mechanisms .....   | 525 |
| Figure 20-11 Bit sequence .....  | 527 |
| Figure 20-12 Various CAN frames .....  | 528 |
| Figure 20-13 Event flag and interrupt generation.....  | 529 |
| Figure 20-14 CAN error state diagram.....  | 530 |
| Figure 21-1 SPI block diagram.....   | 556 |
| Figure 21-2 Selective management of hardware/software.....   | 557 |
| Figure 21-3 Master and slave applications .....  | 558 |
| Figure 21-4 Data clock timing diagram.....   | 559 |
| Figure 21-5 Schematic diagram of the change of TE/RNE/BUSY when the host is continuously transmitting in full duplex mode..... | 560 |
| Figure 21-6 Schematic diagram of TE/BUSY change when the host transmits continuously in one-way only mode .....                | 561 |

|   |     |
|---|-----|
| Figure 21-7 Schematic diagram of RNE change when continuous transmission occurs in receive-only mode (BIDIRMODE = 0 and RONLY = 1)..... | 561 |
| Figure 21-8 Schematic diagram of the change of TE/RNE/BUSY when the slave is continuously transmitting in full duplex mode .....        | 563 |
| Figure 21-9 Schematic diagram of TE/BUSY change during continuous transmission in slave unidirectional transmit-only mode .....         | 563 |
| Figure 21-10 Schematic diagram of TE/BUSY change when BIDIRMODE = 0 and RONLY = 0 are transmitted discontinuously. ....                 | 565 |
| Figure 21-11 Transmission using DMA .....   | 567 |
| Figure 21-12 Reception using DMA .....  | 568 |
| Figure 21-13 I <sup>2</sup> S block diagram.....  | 570 |
| Figure 21-14 I <sup>2</sup> S Philips protocol waveform (16/32-bit full precision, CLKPOL = 0) .....                                    | 572 |
| Figure 21-15 I <sup>2</sup> S Philips protocol standard waveform (24-bit frame, CLKPOL = 0).....  | 572 |
| Figure 21-16 I <sup>2</sup> S Philips protocol standard waveform (16-bit extended to 32-bit packet frame, CLKPOL = 0) .....             | 573 |
| Figure 21-17 The MSB is aligned with 16-bit or 32-bit full precision, CLKPOL = 0.....   | 574 |
| Figure 21-18 MSB aligns 24-bit data, CLKPOL = 0.....  | 574 |
| Figure 21-19 MSB-aligned 16-bit data is extended to 32-bit packet frame, CLKPOL = 0 .....   | 574 |
| Figure 21-20 LSB alignment 16-bit or 32-bit full precision, CLKPOL = 0 .....  | 575 |
| Figure 21-21 LSB aligns 24-bit data, CLKPOL = 0 .....   | 575 |
| Figure 21-22 LSB aligned 16-bit data is extended to 32-bit packet frame, CLKPOL = 0.....  | 576 |
| Figure 21-23 PCM standard waveform (16 bits) .....  | 577 |
| Figure 21-24 PCM standard waveform (16-bit extended to 32-bit packet frame).....  | 577 |
| Figure 21-25 I <sup>2</sup> S clock generator structure .....   | 578 |
| Figure 21-26 Audio sampling frequency definition.....   | 578 |
| Figure 22-1 I <sup>2</sup> C functional block diagram .....   | 594 |
| Figure 22-2 I2C bus protocol.....   | 594 |
| Figure 22-3 Slave transmitter transfer sequence diagram.....  | 597 |
| Figure 22-4 Slave receiver transfer sequence diagram .....  | 598 |
| Figure 22-5 Master transmitter transfer sequence diagram .....  | 600 |
| Figure 22-6 Master receiver transfer sequence diagram.....  | 602 |
| Figure 23-1 USART block diagram.....  | 622 |
| Figure 23-2 word length = 8 setting.....  | 623 |
| Figure 23-3 word length = 9 setting.....  | 624 |

|  |     |
|--|-----|
| Figure 23-4 configuration stop bit .....   | 625 |
| Figure 23-5 TXC/TXDE changes during transmission.....                                      | 627 |
| Figure 23-6 Start bit detection .....  | 627 |
| Figure 23-7 Transmission using DMA .....   | 633 |
| Figure 23-8 Reception using DMA .....  | 634 |
| Figure 23-9 hardware flow control between two USART .....                                  | 635 |
| Figure 23-10 RTS flow control.....   | 635 |
| Figure 23-11 CTS flow controls .....   | 636 |
| Figure 23-12 Mute mode using idle line detection .....                                     | 637 |
| Figure 23-13 Mute mode detected using address mark .....                                   | 638 |
| Figure 23-14 USART synchronous transmission example .....                                  | 639 |
| Figure 23-15 USART data clock timing example (WL=0).....                                   | 639 |
| Figure 23-16 USART data clock timing example (WL=1).....                                   | 640 |
| Figure 23-17 RX data sampling / holding time .....   | 640 |
| Figure 23-18 IrDASIRENDEC-Block diagram.....   | 642 |
| Figure 23-19 IrDA data Modulation (3/16)-normal mode .....                                 | 642 |
| Figure 23-20 Break detection in LIN mode (11-bit break length-the LINBDL bit is set) ..... | 643 |
| Figure 23-21 Break detection and framing error detection in LIN mode .....                 | 644 |
| Figure 23-22 ISO7816-3 Asynchronous Protocol.....  | 645 |
| Figure 23-23 Use 1.5 stop bits to detect parity errors.....                                | 646 |
| Figure 24-1 QSPI block diagram .....   | 658 |
| Figure 24-2 QSPI command sequence.....   | 659 |
| Figure 25-1 Ethernet Module Block Diagram .....  | 688 |
| Figure 25-2 MAC frame format and frame structure.....                                      | 689 |
| Figure 25-3 SMI interface signal line .....  | 690 |
| Figure 25-4 MII interface signal line.....   | 692 |
| Figure 25-5 MII clock source .....   | 693 |
| Figure 25-6 RMII interface signal line .....   | 694 |
| Figure 25-7 RMII clock source.....   | 694 |
| Figure 25-8 Two structures of descriptor.....  | 707 |
| Figure 25-9 System time precision calibration .....  | 722 |
| Figure 26-1 Comparator1 and comparator2 connection diagram .....                           | 771 |

|  |     |
|--|-----|
| Figure 26-2 Comparator3 and comparator4 connection diagram .....             | 772 |
| Figure 26-3 Comparator5,Comparator6,comparator7 connection diagram.....      | 773 |
| Figure 27-1 Block diagram of OPAMP1 and OPAMP2 connection diagram.....       | 786 |
| Figure 27-2 Block diagram of OPAMP3 and OPAMP4 connection diagram.....       | 787 |
| Figure 27-3 Simulation module linkage relationship 1.....                    | 788 |
| Figure 27-4 Simulation module linkage relationship 2.....                    | 789 |
| Figure 27-5 OPAMP standalone operational amplifier mode .....                | 790 |
| Figure 27-6 Follow mode .....  | 791 |
| Figure 27-7 Internal gain mode .....   | 792 |
| Figure 27-8 Internal gain mode with filter.....                              | 792 |
| Figure 28-1 DVP interface timing example.....                                | 798 |
| Figure 29-1 N32G45x level and Cortex™-M4F level debugging block diagram..... | 809 |

# 1 Abbreviations in the text

## 1.1 List of abbreviations for registers

The following abbreviations are used in register descriptions:

|                               |   |
|-------------------------------|---|
| read/write(rw)                | Software can read and write these bits.   |
| read-only(r)                  | Software can only read these bits.  |
| write-only(w)                 | Software can only write this bit, and reading this bit will return the reset value.                                     |
| read/clear(rc_w1)             | Software can read this bit or clear it by writing '1', and writing '0' has no effect on this bit.                       |
| read/clear(rc_w0)             | Software can read this bit or clear it by writing '0', and writing '1' has no effect on this bit.                       |
| read/clear by read(rc_r)      | Software can read this bit. Reading this bit will automatically clear it to '0'. Writing '0' has no effect on this bit. |
| read/set(rs)                  | Software can read or set this bit. Writing '0' has no effect on this bit.   |
| read-only write trigger(rt_w) | Software can read this bit and write '0' or '1' to trigger an event, but it has no effect on this bit value.            |
| toggle(t)                     | Software can only flip this bit by writing '1', and writing '0' has no effect on this bit.                              |
| Reserved(Res.)                | Reserved bit, must be kept at reset value.  |

## 1.2 Available peripherals

For all models of N32G45x microcontroller series, the existence and number of a peripheral, please refer to the data sheet of the corresponding model.

## 2 Interrupts and events

### 2.1 Nested vectored interrupt controller

#### Features

- 86 maskable interrupt channels (excluding 16 interrupt lines of Cortex-M4).
- 16 programmable priority levels (4-bit interrupt priority level is used);
- Low-latency exception and interrupt handling;
- Power management control;
- Implementation of system control register;

Nested Vector Interrupt Controller (NVIC) is closely connected with the interface of processor core, which can realize low-latency interrupt handling and efficiently handle late interrupts. The nested vector interrupt controller manages interrupts including kernel exceptions.

#### 2.1.1 SysTick calibration value register

The system tick calibration value is fixed at 18000. When the system tick clock is set to 18 MHz, a 1ms time reference is generated.

#### 2.1.2 Interrupt and exception vectors

Table 2-1 Vector table

| Position | Priority | Type of priority | Acronym                      | Description   | Address                     |
|----------|----------|------------------|------------------------------|---|-----------------------------|
|          | -        | -                | -                            | Reserved  | 0x0000_0000                 |
|          | -3       | Fixed            | Reset                        | Reset   | 0x0000_0004                 |
|          | -2       | Fixed            | NMI                          | Unmatchable interrupt<br>RCC Clock Security System (CSS) is coupled to NMI vector | 0x0000_0008                 |
|          | -1       | Fixed            | Hardware failure (HardFault) | All types of failures   | 0x0000_000C                 |
|          | 0        | Settable         | Management (MemManage)       | Memory management   | 0x0000_0010                 |
|          | 1        | Settable         | BusFault (bus fault)         | Refers to prefetch failure, memory access failure.                                | 0x0000_0014                 |
|          | 2        | Settable         | Error (UsageFault)           | Undefined instruction or illegal status   | 0x0000_0018                 |
|          | -        | -                | -                            | Reserved  | 0x0000_001C<br>~0x0000_002B |
|          | 3        | Settable         | SVCcall                      | System service call through SWI instruction                                       | 0x0000_002C                 |
|          | 4        | Settable         | DebugMonitor (debug monitor) | Debugging monitor   | 0x0000_0030                 |
|          | -        | -                | -                            | Reserved  | 0x0000_0034                 |
|          | 5        | Settable         | PendSV                       | System services that can be suspended   | 0x0000_0038                 |
|          | 6        | Settable         | SysTick                      | System tick timer   | 0x0000_003C                 |

| Position | Priority | Type of priority | Acronym         | Description  | Address     |
|----------|----------|------------------|-----------------|--|-------------|
| 0        | 7        | Settable         | WWDG            | Window timer interrupt   | 0x0000_0040 |
| 1        | 8        | Settable         | PVD             | Power supply voltage detection (PVD) interrupt connected to EXTI line 16 | 0x0000_0044 |
| 2        | 9        | Settable         | TAMPER          | Intrusion detection interrupt  | 0x0000_0048 |
| 3        | 10       | Settable         | RTC_WKUP        | The real-time clock (RTC) wake-up interrupt connected to EXTI line 20    | 0x0000_004C |
| 4        | 11       | Settable         | FLASH           | Flash global interrupt   | 0x0000_0050 |
| 5        | 12       | Settable         | RCC             | Reset and clock control (RCC) interrupt                                  | 0x0000_0054 |
| 6        | 13       | Settable         | EXTI0           | EXTI line 0 interrupt  | 0x0000_0058 |
| 7        | 14       | Settable         | EXTI1           | EXTI line 1 interrupt  | 0x0000_005C |
| 8        | 15       | Settable         | EXTI2           | EXTI line 2 interrupt  | 0x0000_0060 |
| 9        | 16       | Settable         | EXTI3           | EXTI line 3 interrupt  | 0x0000_0064 |
| 10       | 17       | Settable         | EXTI4           | EXTI line 4 interrupt  | 0x0000_0068 |
| 11       | 18       | Settable         | DMA1 channel 1  | DMA1 channel 1 global interrupt  | 0x0000_006C |
| 12       | 19       | Settable         | DMA1 channel 2  | DMA1 channel 2 global interrupt  | 0x0000_0070 |
| 13       | 20       | Settable         | DMA1 channel 3  | DMA1 channel 3 global interrupt  | 0x0000_0074 |
| 14       | 21       | Settable         | DMA1 channel 4  | DMA1 channel 4 global interrupt  | 0x0000_0078 |
| 15       | 22       | Settable         | DMA1 channel 5  | DMA1 channel 5 global interrupt  | 0x0000_007C |
| 16       | 23       | Settable         | DMA1 channel 6  | DMA1 channel 6 global interrupt  | 0x0000_0080 |
| 17       | 24       | Settable         | DMA1 channel 7  | DMA1 channel 7 global interrupt  | 0x0000_0084 |
| 18       | 25       | Settable         | ADC1_2          | ADC1 and ADC2 global interrupts  | 0x0000_0088 |
| 19       | 26       | Settable         | USB_HP_CAN1_TX  | USB high priority interrupt /CAN1 send interrupt                         | 0x0000_008C |
| 20       | 27       | Settable         | USB_LP_CAN1_RX0 | USB low priority interrupt /CAN1 receives 0 interrupt                    | 0x0000_0090 |
| 21       | 28       | Settable         | CAN1_RX1        | CAN1 receive 1 interrupt   | 0x0000_0094 |
| 22       | 29       | Settable         | CAN_SCE         | CAN1 SCE interrupt   | 0x0000_0098 |
| 23       | 30       | Settable         | EXTI9_5         | EXTI line [9:5] interrupt  | 0x0000_009C |
| 24       | 31       | Settable         | TIM1_BRK        | TIM1 brake interrupt   | 0x0000_00A0 |
| 25       | 32       | Settable         | TIM1_UP         | TIM1 update interrupt  | 0x0000_00A4 |
| 26       | 33       | Settable         | TIM1_TRG_COM    | TIM1 trigger and communication interrupt                                 | 0x0000_00A8 |
| 27       | 34       | Settable         | TIM1_CC         | TIM1 capture comparison interrupt  | 0x0000_00AC |
| 28       | 35       | Settable         | TIM2            | TIM2 global interrupt  | 0x0000_00B0 |
| 29       | 36       | Settable         | TIM3            | TIM3 global interrupt  | 0x0000_00B4 |
| 30       | 37       | Settable         | TIM4            | TIM4 global interrupt  | 0x0000_00B8 |
| 31       | 38       | Settable         | I2C1_EV         | I2C1 event interrupt   | 0x0000_00BC |
| 32       | 39       | Settable         | I2C1_ER         | I2C1 error interrupt   | 0x0000_00C0 |
| 33       | 40       | Settable         | I2C2_EV         | I2C2 event interrupt   | 0x0000_00C4 |
| 34       | 41       | Settable         | I2C2_ER         | I2C2 error interrupt   | 0x0000_00C8 |
| 35       | 42       | Settable         | SPI1            | SPI1 global interrupt  | 0x0000_00CC |
| 36       | 43       | Settable         | SPI2_I2S2       | SPI2/I2S2 global interrupt   | 0x0000_00D0 |

| Position | Priority | Type of priority | Acronym        | Description  | Address     |
|----------|----------|------------------|----------------|--|-------------|
| 37       | 44       | Settable         | USART1         | USART1 global interrupt                              | 0x0000_00D4 |
| 38       | 45       | Settable         | USART2         | USART2 global interrupt                              | 0x0000_00D8 |
| 39       | 46       | Settable         | USART3         | USART3 global interrupt                              | 0x0000_00DC |
| 40       | 47       | Settable         | EXTI15_10      | EXTI line [15:10] interrupt                          | 0x0000_00E0 |
| 41       | 48       | Settable         | RTCAlarm       | RTC alarm interrupt connected to EXTI line 17        | 0x0000_00E4 |
| 42       | 49       | Settable         | USBWKUP        | USB wake-up interrupt connected to EXTI line 18      | 0x0000_00E8 |
| 43       | 50       | Settable         | TIM8_BRK       | TIM8 brake interrupt                                 | 0x0000_00EC |
| 44       | 51       | Settable         | TIM8_UP        | TIM8 update interrupt                                | 0x0000_00F0 |
| 45       | 52       | Settable         | TIM8_TRG_COM   | TIM8 trigger and communication interrupt             | 0x0000_00F4 |
| 46       | 53       | Settable         | TIM8_CC        | TIM8 capture comparison interrupt                    | 0x0000_00F8 |
| 47       | 54       | Settable         | ADC3_4         | ADC3 and ADC4 global interrupts                      | 0x0000_00FC |
| 48       | 55       | Settable         | Reserved       | Reserved   | 0x0000_0100 |
| 49       | 56       | Settable         | SDIO           | SDIO global interrupt                                | 0x0000_0104 |
| 50       | 57       | Settable         | TIM5           | TIM5 global interrupt                                | 0x0000_0108 |
| 51       | 58       | Settable         | SPI3_I2S3      | SPI3/I2S3 global interrupt                           | 0x0000_010C |
| 52       | 59       | Settable         | UART4          | UART4 global interrupt                               | 0x0000_0110 |
| 53       | 60       | Settable         | UART5          | UART5 global interrupt                               | 0x0000_0114 |
| 54       | 61       | Settable         | TIM6           | TIM6 global Interrupt                                | 0x0000_0118 |
| 55       | 62       | Settable         | TIM7           | TIM7 global interrupt                                | 0x0000_011C |
| 56       | 63       | Settable         | DMA2 channel 1 | DMA2 channel 1 global interrupt                      | 0x0000_0120 |
| 57       | 64       | Settable         | DMA2 channel 2 | DMA2 channel 2 global interrupt                      | 0x0000_0124 |
| 58       | 65       | Settable         | DMA2 channel 3 | DMA2 channel 3 global interrupt                      | 0x0000_0128 |
| 59       | 66       | Settable         | DMA2 channel 4 | DMA2 channel 4 global interrupt                      | 0x0000_012C |
| 60       | 67       | Settable         | DMA2 channel 5 | DMA2 channel 5 global interrupt                      | 0x0000_0130 |
| 61       | 68       | Settable         | ETH            | Ethernet global interrupt                            | 0x0000_0134 |
| 62       | 69       | Settable         | ETH_WKUP       | Ethernet wake-up interrupt connected to EXTI line 19 | 0x0000_0138 |
| 63       | 70       | Settable         | CAN2_TX        | CAN2 send interrupt                                  | 0x0000_013C |
| 64       | 71       | Settable         | CAN2_RX0       | CAN2 receive 0 interrupt                             | 0x0000_0140 |
| 65       | 72       | Settable         | CAN2_RX1       | CAN2 receive 1 interrupt                             | 0x0000_0144 |
| 66       | 73       | Settable         | CAN2_SCE       | CAN 2SCE interrupt                                   | 0x0000_0148 |
| 67       | 74       | Settable         | QSPI           | QSPI global interrupt                                | 0x0000_014C |
| 68       | 75       | Settable         | DMA2 channel 6 | DMA2 channel 6 global interrupt                      | 0x0000_0150 |
| 69       | 76       | Settable         | DMA2 channel 7 | DMA2 channel 7 global interrupt                      | 0x0000_0154 |
| 70       | 77       | Settable         | I2C3_EV        | I2C3 event interrupt                                 | 0x0000_0158 |
| 71       | 78       | Settable         | I2C3_ER        | I2C3 error interrupt                                 | 0x0000_015C |
| 72       | 79       | Settable         | I2C4_EV        | I2C4 event interrupt                                 | 0x0000_0160 |
| 73       | 80       | Settable         | I2C4_ER        | I2C4 error interrupt                                 | 0x0000_0164 |
| 74       | 81       | Settable         | UART6          | UART6 global interrupt                               | 0x0000_0168 |

| Position | Priority | Type of priority | Acronym        | Description                          | Address     |
|----------|----------|------------------|----------------|--------------------------------------|-------------|
| 75       | 82       | Settable         | UART7          | UART7 global interrupt               | 0x0000_016C |
| 76       | 83       | Settable         | DMA1 channel 8 | DMA1 channel 8 global interrupt      | 0x0000_0170 |
| 77       | 84       | Settable         | DMA2 channel 8 | DMA2 channel 8 global interrupt      | 0x0000_0174 |
| 78       | 85       | Settable         | DVP            | DVP global interrupt                 | 0x0000_0178 |
| 79       | 86       | Settable         | BAG            | SAC global interrupt                 | 0x0000_017C |
| 80       | 87       | Settable         | MMU            | MMU global interrupt                 | 0x0000_0180 |
| 81       | 88       | Settable         | Reserved       | Reserved                             | 0x0000_0184 |
| 82       | 89       | Settable         | COMP_1_2_3     | COMP1, COMP2, COMP3 global interrupt | 0x0000_0188 |
| 83       | 90       | Settable         | COMP_4_5_6     | COMP4, COMP5, COMP6 global interrupt | 0x0000_018C |
| 84       | 91       | Settable         | COMP7          | COMP7 global interrupt               | 0x0000_0190 |
| 85       | 92       | Settable         | R-SRAM         | R-SRAM error interrupt               | 0x0000_0194 |

## 2.2 External interrupt/event controller (EXTI)

### 2.2.1 Introduction

The external interrupt/event controller includes 21 edge detection circuits that generate interrupt/event triggers. Each input line can be independently configured with pulse or pending level input type, and three trigger event types of rising edge, falling edge or both edge can also be independently configured. The pending register holds the interrupt request of the status line, The interrupt request can be cleared by writing a '1' operation in the corresponding bit of the Pending register.

### 2.2.2 Main features

The main features of EXTI controller are as follows:

- Support 21 software interrupt/event requests
- The corresponding interrupt/event of each input line can be independently configured with trigger or mask.
- Each interrupt line has an independent status bit.
- Support pulse or suspend input type
- Three types of trigger events are supported: rising edge, falling edge or double edge.
- Wake-up to exit power-saving mode

Figure 2-1 External interrupt/event controller block diagram

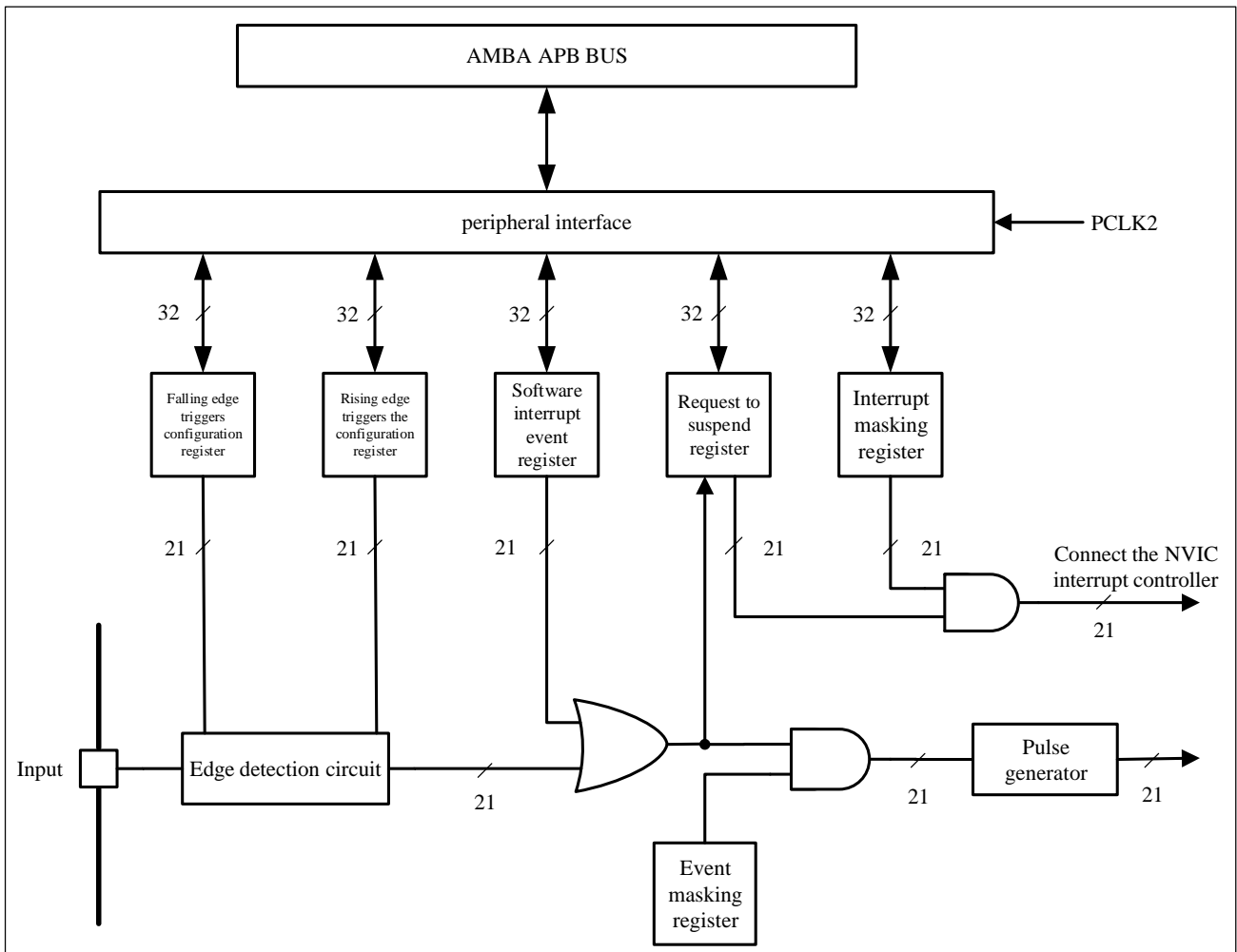

### 2.2.3 Functional description

EXTI contains 21 interrupt lines, of which 16 are from I/O pins and 5 are from internal peripherals or modules. To generate an interrupt, the NVIC interrupt channel of the external interrupt controller must be configured to enable the corresponding interrupt line. Select the type of rising edge, falling edge or double edge trigger event through edge trigger configuration registers `EXTI_RT_CFG` and `EXTI_FT_CFG`, and write '1' to the corresponding bit of the interrupt mask register `EXTI_IMASK` to open the interrupt request. When the preset edge trigger polarity is detected on the external interrupt line, an interrupt request will be generated and the corresponding Pending bit will be set to '1'. Writing '1' in the corresponding bit of the Pending register will clear the interrupt request.

To generate an event, the corresponding event line must be configured and enabled. According to the required polarity of edge detection, set the rising/falling edge trigger configuration register, and write '1' in the corresponding bit of the event mask register to allow the interrupt request. When the preset edge occurs on the event line, an event request pulse will be generated, and the corresponding Pending bit will not be set to '1'.

In addition, by writing '1' in the software interrupt/event register, an interrupt/event request can also be generated by software.

- Hardware interrupt configuration, select and configure 21 lines as interrupt sources as required:

- ◆ Configure the mask bits of 21 interrupt lines (EXTI\_IMASK);
- ◆ Configure the trigger configuration bits (EXTI\_RT\_CFG and EXTI\_FT\_CFG) of the selected disconnection;
- ◆ Configure the enable and mask bits that control the NVIC interrupt channel mapped to the External Interrupt Controller so that an interrupt coming from one of the 21 lines can be correctly acknowledged.
- Hardware configuration, select and configure 21 lines as event sources as required:
  - ◆ Configure the mask bits of 21 event lines (EXTI\_EMASK);
  - ◆ Configure the trigger selection bits (EXTI\_RT\_CFG and EXTI\_FT\_CFG) of the event lines.
- Software interrupt/event configuration, select and configure 21 lines as software interrupt/event lines as required:
  - ◆ Configure 21 interrupt/event line mask bits (EXTI\_IMASK, EXTI\_EMASK);
  - ◆ Configure the request bit of the software interrupt event register (EXTI\_SWIE).

## 2.2.4 EXTI line mapping

Figure 2-2 External interrupt GPIO mapping

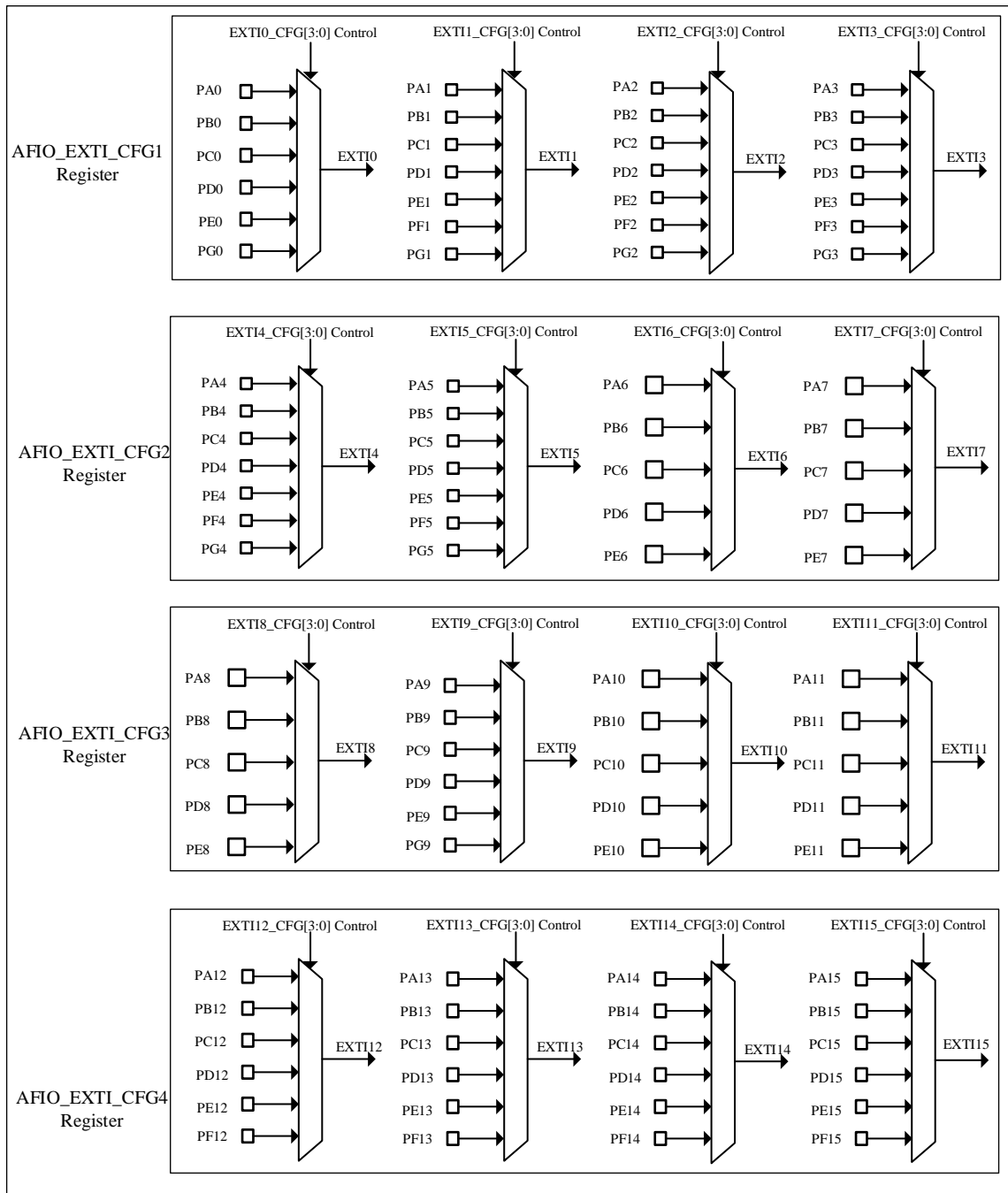

To configure external interrupts/events on the GPIO line through AFIO\_EXTI\_CFGy, the AFIO clock must be enabled first. The general I/O port is connected to 16 external interrupt/event lines in the way shown above. The other 5 EXTI lines are connected as follows:

- The EXTI line 16 is connected to PVD output
- The EXTI line 17 is connected to RTC alarm event
- The EXTI line 18 is connected to the USB wake-up event
- The EXTI line 19 is connected to the Ethernet wake-up event.
- The EXTI line 20 is connected to RTC wake-up event

## 2.3 EXTI registers

EXTI base address: 0x40010400

### 2.3.1 EXTI register review

Table 2-2 EXTI register review

| Offset | Register    | 31       | 30 | 29 | 28 | 27 | 26 | 25 | 24 | 23 | 22 | 21 | 20 | 19           | 18     | 17     | 16         | 15     | 14     | 13     | 12     | 11     | 10     | 9      | 8     | 7     | 6     | 5     | 4     | 3     | 2     | 1     | 0     |       |
|--------|-------------|----------|----|----|----|----|----|----|----|----|----|----|----|--------------|--------|--------|------------|--------|--------|--------|--------|--------|--------|--------|-------|-------|-------|-------|-------|-------|-------|-------|-------|-------|
| 000h   | EXTI_IMASK  | Reserved |    |    |    |    |    |    |    |    |    |    |    | IMASK[20:0]  |        |        |            |        |        |        |        |        |        |        |       |       |       |       |       |       |       |       |       |       |
|        | Reset Value | 0        | 0  | 0  | 0  | 0  | 0  | 0  | 0  | 0  | 0  | 0  | 0  | 0            | 0      | 0      | 0          | 0      | 0      | 0      | 0      | 0      | 0      | 0      | 0     | 0     | 0     | 0     | 0     | 0     | 0     | 0     | 0     |       |
| 004h   | EXTI_EMASK  | Reserved |    |    |    |    |    |    |    |    |    |    |    | EMASK[20:0]  |        |        |            |        |        |        |        |        |        |        |       |       |       |       |       |       |       |       |       |       |
|        | Reset Value | 0        | 0  | 0  | 0  | 0  | 0  | 0  | 0  | 0  | 0  | 0  | 0  | 0            | 0      | 0      | 0          | 0      | 0      | 0      | 0      | 0      | 0      | 0      | 0     | 0     | 0     | 0     | 0     | 0     | 0     | 0     | 0     |       |
| 008h   | EXTI_RT_CFG | Reserved |    |    |    |    |    |    |    |    |    |    |    | RT_CFG[20:0] |        |        |            |        |        |        |        |        |        |        |       |       |       |       |       |       |       |       |       |       |
|        | Reset Value | 0        | 0  | 0  | 0  | 0  | 0  | 0  | 0  | 0  | 0  | 0  | 0  | 0            | 0      | 0      | 0          | 0      | 0      | 0      | 0      | 0      | 0      | 0      | 0     | 0     | 0     | 0     | 0     | 0     | 0     | 0     | 0     |       |
| 00Ch   | EXTI_FT_CFG | Reserved |    |    |    |    |    |    |    |    |    |    |    | FT_CFG[20:0] |        |        |            |        |        |        |        |        |        |        |       |       |       |       |       |       |       |       |       |       |
|        | Reset Value | 0        | 0  | 0  | 0  | 0  | 0  | 0  | 0  | 0  | 0  | 0  | 0  | 0            | 0      | 0      | 0          | 0      | 0      | 0      | 0      | 0      | 0      | 0      | 0     | 0     | 0     | 0     | 0     | 0     | 0     | 0     | 0     |       |
| 010h   | EXTI_SWIE   | Reserved |    |    |    |    |    |    |    |    |    |    |    | SWIE[20:0]   |        |        |            |        |        |        |        |        |        |        |       |       |       |       |       |       |       |       |       |       |
|        | Reset Value | 0        | 0  | 0  | 0  | 0  | 0  | 0  | 0  | 0  | 0  | 0  | 0  | 0            | 0      | 0      | 0          | 0      | 0      | 0      | 0      | 0      | 0      | 0      | 0     | 0     | 0     | 0     | 0     | 0     | 0     | 0     | 0     |       |
| 014h   | EXTI_PEND   | Reserved |    |    |    |    |    |    |    |    |    |    |    | PEND20       | PEND19 | PEND18 | PEND17     | PEND16 | PEND15 | PEND14 | PEND13 | PEND12 | PEND11 | PEND10 | PEND9 | PEND8 | PEND7 | PEND6 | PEND5 | PEND4 | PEND3 | PEND2 | PEND1 | PEND0 |
|        | Reset Value | 0        | 0  | 0  | 0  | 0  | 0  | 0  | 0  | 0  | 0  | 0  | 0  | 0            | 0      | 0      | 0          | 0      | 0      | 0      | 0      | 0      | 0      | 0      | 0     | 0     | 0     | 0     | 0     | 0     | 0     | 0     | 0     | 0     |
| 018h   | EXTI_TS_SEL | Reserved |    |    |    |    |    |    |    |    |    |    |    |              |        |        | TSSEL[3:0] |        |        |        |        |        |        |        |       |       |       |       |       |       |       |       |       |       |
|        | Reset Value | 0        | 0  | 0  | 0  | 0  | 0  | 0  | 0  | 0  | 0  | 0  | 0  | 0            | 0      | 0      | 0          | 0      | 0      | 0      | 0      | 0      | 0      | 0      | 0     | 0     | 0     | 0     | 0     | 0     | 0     | 0     |       |       |

### 2.3.2 EXTI interrupt mask register (EXTI\_IMASK)

Address offset: 0x00

Reset value: 0x0000 0000

|          |         |         |         |         |         |        |        |        |        |        |        |         |         |         |         |         |
|----------|---------|---------|---------|---------|---------|--------|--------|--------|--------|--------|--------|---------|---------|---------|---------|---------|
| Reserved |         |         |         |         |         |        |        |        |        |        |        | IMASK20 | IMASK19 | IMASK18 | IMASK17 | IMASK16 |
| IMASK15  | IMASK14 | IMASK13 | IMASK12 | IMASK11 | IMASK10 | IMASK9 | IMASK8 | IMASK7 | IMASK6 | IMASK5 | IMASK4 | IMASK3  | IMASK2  | IMASK1  | IMASK0  |         |
| rw       | rw      | rw      | rw      | rw      | rw      | rw     | rw     | rw     | rw     | rw     | rw     | rw      | rw      | rw      | rw      |         |

| Bit field | Name     | Description  |
|-----------|----------|--|
| 31:21     | Reserved | Reserved, the reset value must be maintained.  |
| 20:0      | IMASKx   | Interrupt mask on line x<br>0: Interrupt request from line x is masked;<br>1: Interrupt request from line x is not masked. |

### 2.3.3 EXTI event mask register (EXTI\_EMASK)

Address offset: 0x04

Reset value: 0x0000 0000

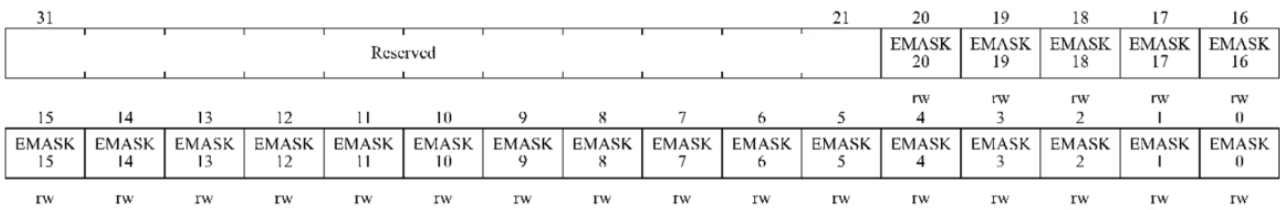

| Bit field | Name     | Description   |
|-----------|----------|---|
| 31:21     | Reserved | Reserved, the reset value must be maintained.   |
| 20:0      | EMASKx   | Event mask on line x<br>0: Event request from line x is masked;<br>1: Event request from line x is not masked |

### 2.3.4 Rising trigger selection register (EXTI\_RT\_CFG)

Address offset: 0x08

Reset value: 0x0000 0000

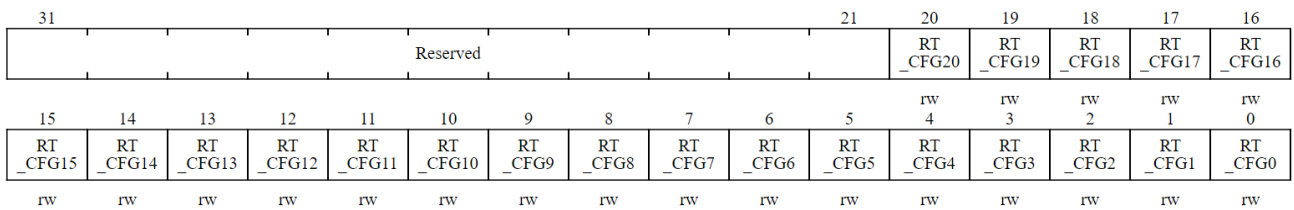

| Bit field | Name     | Description  |
|-----------|----------|--|
| 31:21     | Reserved | Reserved, the reset value must be maintained.  |
| 20:0      | RT_CFGx  | Rising trigger event configuration bit of line x.<br>0: Rising trigger disabled (interrupts and events) for input line x.<br>1: Rising trigger enabled (interrupts and events) for input line x. |

### 2.3.5 Falling trigger selection register (EXTI\_FT\_CFG)

Address offset: 0x0C

Reset value: 0x0000 0000

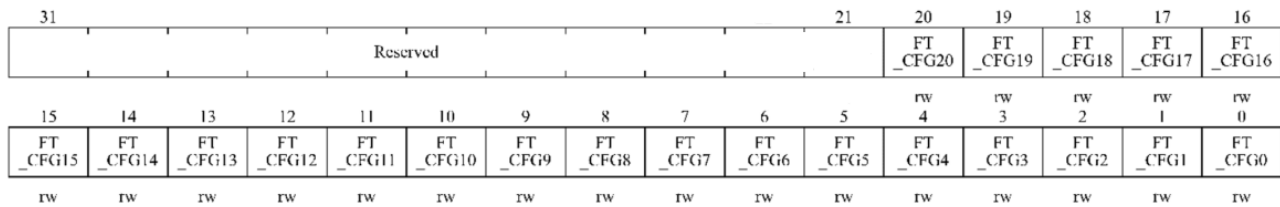

| Bit field | Name     | Description   |
|-----------|----------|---|
| 31:21     | Reserved | Reserved, the reset value must be maintained.   |
| 20:0      | FT_CFGx  | Falling trigger event configuration bit of line x.<br>0: Falling trigger disabled (interrupts and events) for input line x. |

| Bit field | Name | Description  |
|-----------|------|--|
|           |      | 1: Falling trigger enabled (interrupts and events) for input line x. |

### 2.3.6 EXTI software interrupt event register (EXTI\_SWIE)

Address offset: 0x10

Reset value: 0x0000 0000

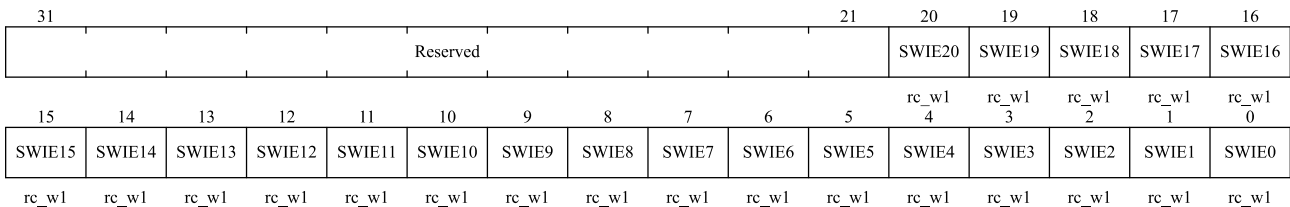

| Bit field | Name              | Description   |
|-----------|-------------------|---|
| 31:21     | Reserved          | Reserved, the reset value must be maintained.   |
| 20:0      | SWIE <sub>x</sub> | Software interrupt on line x<br>When this bit is '0', writing '1' will set the corresponding Pending bit in EXTI_PEND.<br>If this interrupt is allowed in EXTI_IMASK and EXTI_EMASK, an interrupt will be generated at this time.<br><i>Note: By writing '1' to clear the corresponding bit of EXTI_PEND, this bit can be cleared to '0'.</i> |

### 2.3.7 EXTI pending register (EXTI\_PEND)

Address offset: 0x14

Reset value: 0x0000 0000

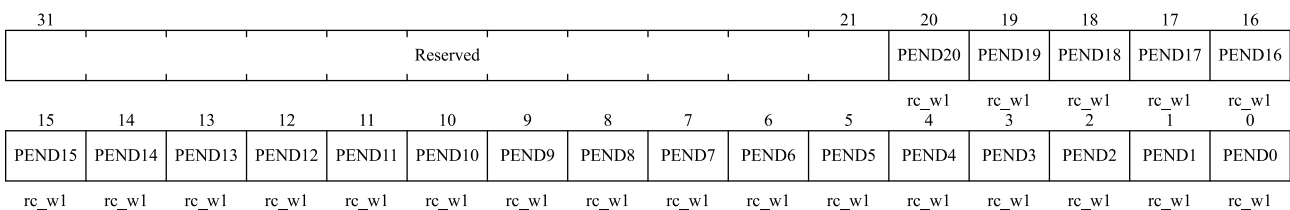

| Bit field | Name              | Description   |
|-----------|-------------------|---|
| 31:21     | Reserved          | Reserved, the reset value must be maintained.   |
| 20:0      | PEND <sub>x</sub> | Pending bit on line x<br>0: No pending request occurred.<br>1: A pending trigger request has occurred.<br>This bit is set to '1' when a selected edge trigger event occurs on the external interrupt line. Write '1' in this bit to clear it, or change the polarity of edge detection to clear this bit. |

### 2.3.8 EXTI timestamp trigger source selection register (EXTI\_TS\_SEL)

Address offset: 0x18

Reset value: 0x0000 0000

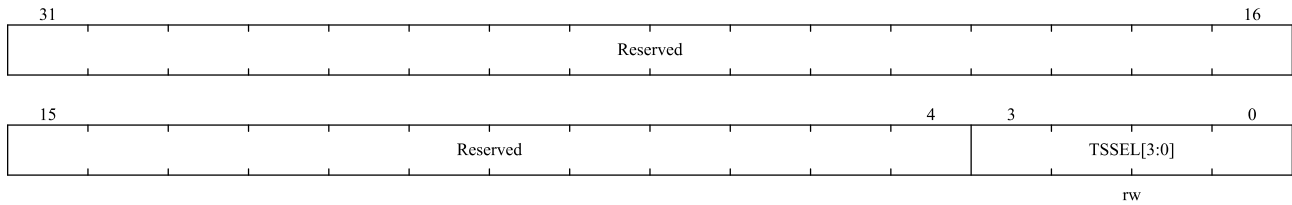

| Bit field | Name       | Description   |
|-----------|------------|---|
| 31:4      | Reserved   | Reserved, the reset value must be maintained.   |
| 3:0       | TSSEL[3:0] | Select external interrupt input as trigger source of timestamp event.<br>0: Select EXTI0 as the trigger source of timestamp event;<br>1: Select EXTI1 as the trigger source of timestamp event;<br>.....<br>15: Select EXTI15 as the trigger source of timestamp event. |

## 3 Memory and bus architecture

### 3.1 System architecture

#### 3.1.1 Bus architecture

Figure 3-1 Bus architecture

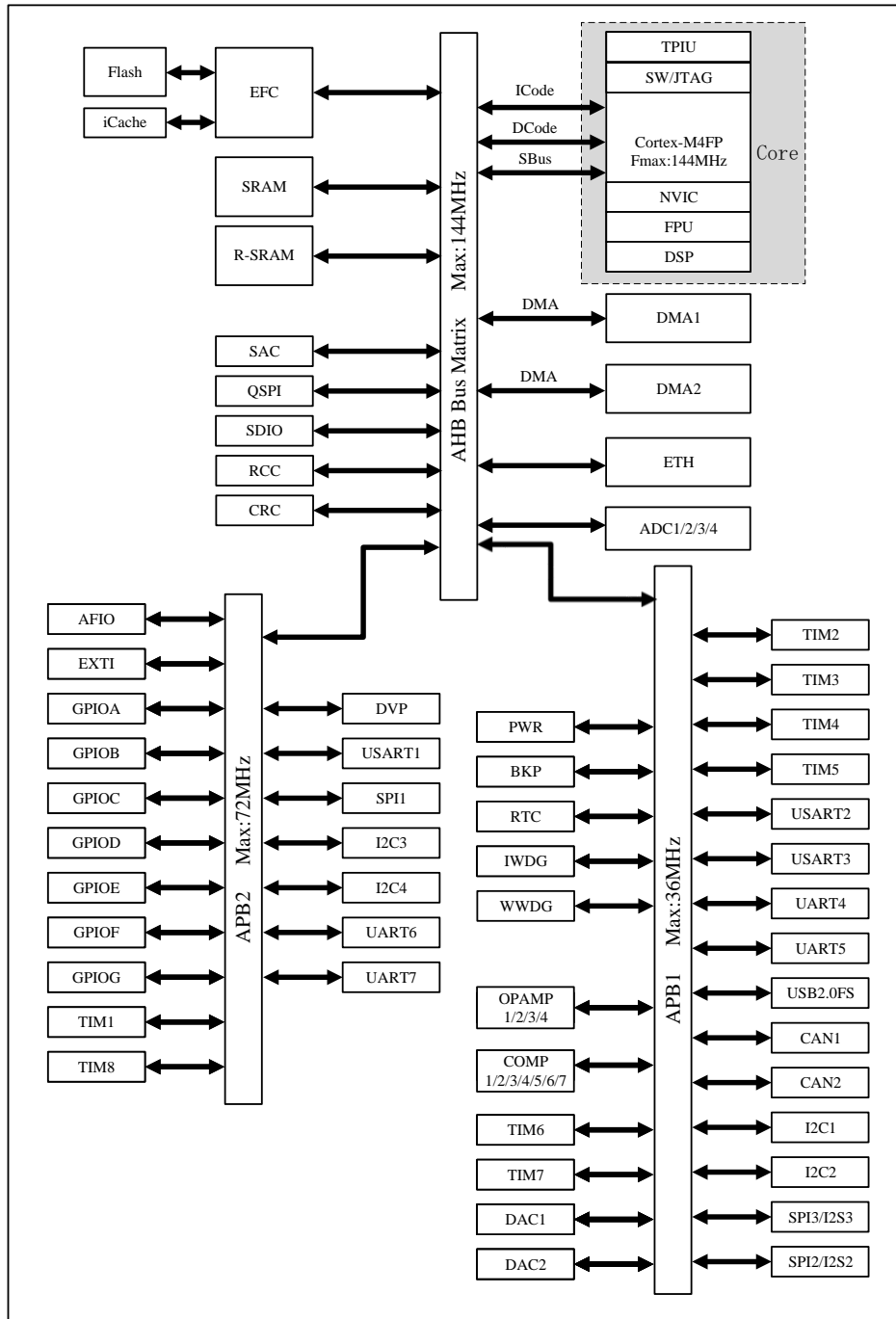

- ICode bus: Connect the ICode bus of Cortex™-M4FP core with the flash instruction interface. Instruction prefetching is completed on this bus.

- The DCode bus connects the DCode bus of Cortex™-M4FP core with the data interface of flash memory (constant loading and debugging access).
- SBus bus connects the SBus bus (peripheral bus) of Cortex™-M4FP core to the bus matrix, which coordinates the access between the core and DMA.
- SAC/CRC has designed matrix interconnection, which supports DMA transmission by software triggering.
- The system consists of two AHB2APB Bridges, i.e. AHB2APB1 and AHB2APB2. Among them, APB1 contains 26 low-speed APB peripherals, and the maximum speed of PCLK1 is 36MHz; APB2 contains 18 high-speed APB peripherals, and the maximum speed of PCLK2 is equal to 72MHz.

### 3.1.2 Bus address mapping

The address mapping includes all AHB and APB peripherals: AHB peripherals, APB1 peripherals, APB2 peripherals, Flash, SRAM, System Memory, etc. And the address space of SRAM is located in the bit-band Region of SRAM, and atomic accesses can be made through the bit-band Alias to performed read-modify-write operations on the target bits of the bit-band region. The address spaces of all APB and AHB peripherals are located in the bit-band Region of the peripherals. Atomic accesses can be made through the bit-band Alias to performed read-modify-write operations on the target bits of the bit-band region. The specific mapping is as follows:

Figure 3-2 Bus address map

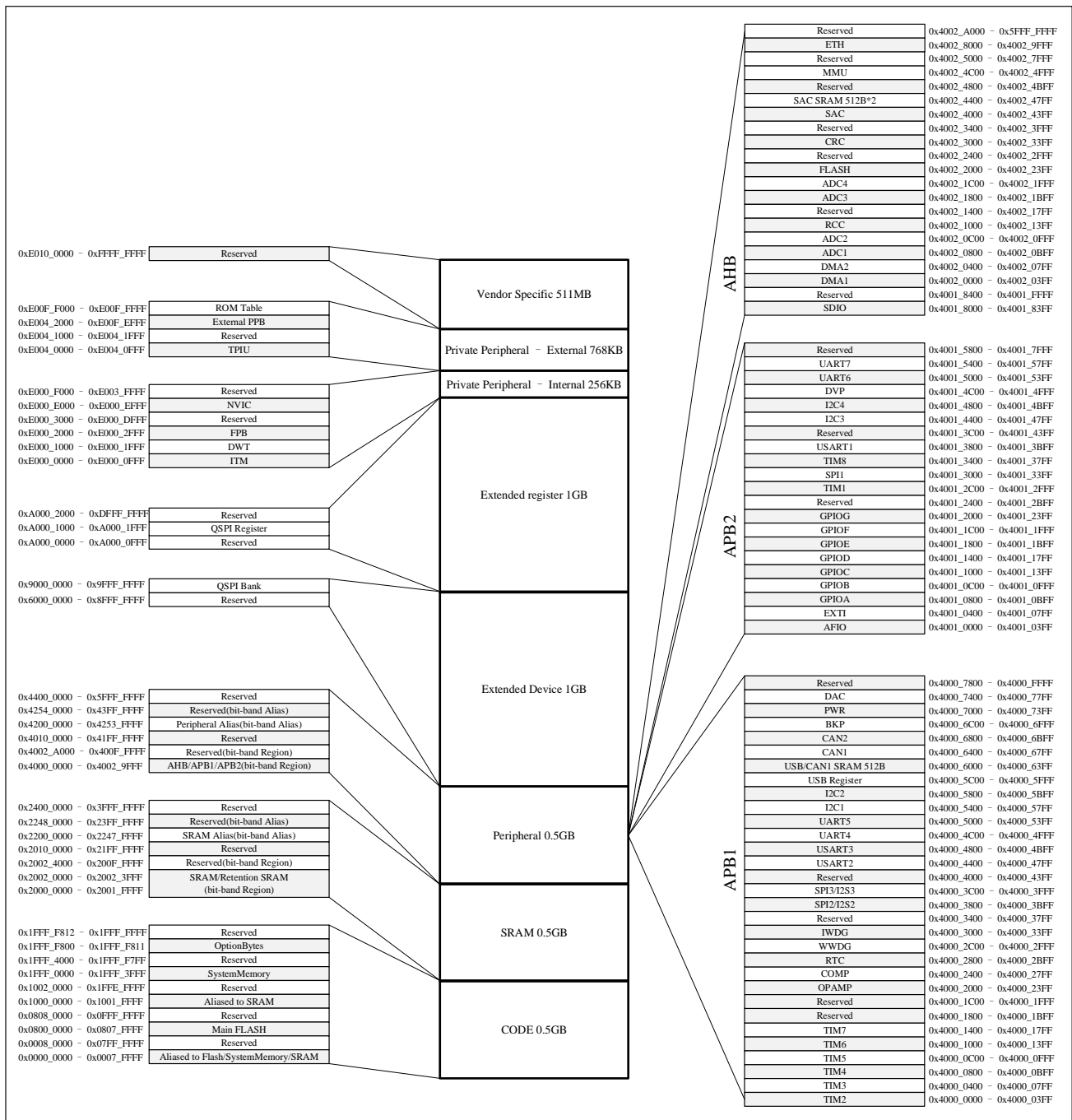

### 3.1.2.1 Bit banding

Cortex™-M4FP memory image includes two bit-band areas. These two bit-band areas map each word in the alias memory area to a bit in the bit-band memory area. When writing a word in the alias area, it is equivalent to performing a read-modify-write operation on the target bits of the bit segment area.

Both the peripheral registers and SRAM are mapped into a bit-band area, which allows a single bit-band area write and read operation to be performed.

The following mapping formula shows how each byte in the alias area corresponds to the corresponding bit in the bit band area:

$\text{bitband\_byte\_addr} = \text{bitband\_base} + (\text{byte\_offset} \times 32) + (\text{bit\_number} \times 4)$

In which:

$\text{bitband\_byte\_addr}$  is the address of the byte in the alias memory area, which is mapped to a certain target bit;

$\text{bitband\_base}$  is the starting address of alias area;

$\text{byte\_offset}$  is the serial number of the byte containing the target bit in the bit-band;

$\text{bit\_number}$  is the position of the target bit (0-7).

For example:

The following example shows how to map bit 4 in bytes with SRAM address 0x20000400 in alias area:

$0x22008010 = 0x22000000 + (0x400 \times 32) + (4 \times 4)$ .

Writing to address 0x22008010 has the same effect as reading-modify-writing to bit 4 of address 0x20000400 bytes in SRAM.

Reading 0x22008010 address returns the value of bit 4 (0x01 or 0x00) of address 0x20000400 bytes in SRAM. Please refer to “Cortex™-M4 Technical Reference Manual” for more information about bit-banding.

### 3.1.3 Boot management

#### 3.1.3.1 Boot address

When the system starts, the boot mode after reset can be selected through BOOT1 and BOOT0 pins. After system reset or exit from standby mode, the value of BOOT pin will be re-latched. After a startup delay, the CPU gets the address at the top of the stack from address 0x0000\_0000 and executes the code from the reset vector address indicated by address 0x0000\_0004. Because of the Cortex™-M4 always gets the stack top pointer and reset vector from addresses 0x0000\_0000 and 0x0000\_0004, so boot is only suitable for starting from the CODE area, and address remapping is designed for boot space. There are three boot modes to choose from:

- Boot from Main Flash:
  - ◆ Main flash memory is mapped to the boot space (0x0000\_0000);
  - ◆ Main flash memory is accessible in two address areas, 0x0000\_0000 or 0x0800\_0000 (ICode/DCode/DMA1/DMA2);
- Boot from System Memory:
  - ◆ System memory is mapped to boot space (0x0000\_0000);
  - ◆ System memory can be accessed in two address areas, 0x0000\_0000 or 0x1FFF\_0000 (ICode/DCode/DMA1/DMA2);
- Boot from the built-in SRAM:
  - ◆ The built-in SRAM is mapped to boot space (0x0000\_0000);
  - ◆ The built-in SRAM is accessible in two address areas, 0x0000\_0000 or 0x2000\_0000 (ICode/DCode/SBus/DMA1/DMA2);

### 3.1.3.2 Boot configuration

In addition, SRAM can also be accessed through virtual address segment 0x1000\_0000, which makes the CPU jump to SRAM to run programs through ICode/DCode after starting from Main Flash or System Memory (note that programs are not started from SRAM and do not belong to startup mode). In addition to the BOOT pin configuration boot program, there are two ways to run the program in SRAM:

- Jump directly to the physical address segment 0x2000\_0000 of SRAM to run the program. At this time, the program will be run through SBus.
- Jump to the virtual address segment 0x1000\_0000 of SRAM, and internally remap to the physical address segment 0x2000\_0000 to run the program. At this time, the program will run efficiently through ICode/DCode.

Table 3-1 List of boot mode

| Boot mode select pin |       | Boot mode           | Specifies the start address for accessing memory space in boot mode |                            |   |
|----------------------|-------|---------------------|---|----------------------------|---|
| BOOT1                | BOOT0 |                     | Main Flash  | System Memory              | SRAM                                      |
| X                    | 0     | Main Flash start    | 0x0000_0000<br>0x0800_0000  | 0x1FFF_0000                | 0x1000_0000<br>0x2000_0000                |
| 0                    | 1     | System Memory start | 0x08000000  | 0x0000_0000<br>0x1FFF_0000 | 0x1000_0000<br>0x2000_0000                |
| 1                    | 1     | SRAM start          | 0x08000000  | 0x1FFF_0000                | 0x0000_0000<br>0x1000_0000<br>0x2000_0000 |

### 3.1.3.3 Embedded boot loader

Embedded boot loader program is stored in the system memory System Memory and is used to reprogram the flash memory through the USART1 or USB-FS interface (full-speed USB device, DFU protocol). The USB-FS interface can only be run when the external clock (HSE) of 4MHz, 6MHz, 8MHz, 12MHz, 16MHz, 18MHz, 24MHz and 32MHz is used. In addition to the above-mentioned 8-frequency external clock (HSE), the USART1 interface can also rely on the internal 8MHz oscillator (HSI) to run. Consult the BOOT user manual for further details.

## 3.2 Memory system

The program memory, data memory, registers and I/O ports are organized in the same 4GB linear address space. Data bytes are stored in the memory in little endian format. The lowest address byte in a word is regarded as the least significant byte of the word, while the highest address byte is the most significant byte. The specifications of program memory and data memory are as follows.

### 3.2.1 FLASH specification

Flash consists of a main storage area and an information area, which are described separately below: (Capacity values in the following description do not include ECC)

- The maximum main memory area is 512KB, also known as main flash memory, which contains 256 Page for storing and running user programs and storing data.
- The information area is 20KB, including 10 Page, and consists of system storage area (16KB), system

configuration area (2KB) and option byte area (2KB).

- ◆ The System Memory area is 16KB, which contains 8 Page, also known as System Memory, and is used to store and run the BOOT program.
- ◆ The system configuration area is 2KB, including 1 Page.
- ◆ The Option Byte area is 2KB, containing 1 Page, also known as Option Byte, and the effective space is 18B, BOOT programs and user programs can be read, written or erased.

### 3.2.1.1 Flash memory module organization

Bus address space is allocated to the main storage area and the information area.

Table 3-2 Flash bus address list

| Memory area                          | Page name                 | Address range             | Size |
|--------------------------------------|---------------------------|---------------------------|------|
| Main memory area                     | Page 0                    | 0x0800_0000 – 0x0800_07FF | 2KB  |
|                                      | Page 1                    | 0x0800_0800 – 0x0800_0FFF | 2KB  |
|                                      | Page 2                    | 0x0800_1000 – 0x0800_17FF | 2KB  |
|                                      | ⋮                         | ⋮                         | ⋮    |
|                                      | Page 255                  | 0x0807_F800 – 0x0807_FFFF | 2KB  |
| Information area                     | System memory area        | 0x1FFF_0000 – 0x1FFF_3FFF | 16KB |
|                                      | System configuration area | 0x1FFF_F000 – 0x1FFF_F7FF | 2KB  |
|                                      | Option byte area          | 0x1FFF_F800 – 0x1FFF_F811 | 18B  |
| Memory area<br>interface<br>register | FLASH_AC                  | 0x4002_2000 – 0x4002_2003 | 4B   |
|                                      | FLASH_KEY                 | 0x4002_2004 – 0x4002_2007 | 4B   |
|                                      | FLASH_OPTKEY              | 0x4002_2008 – 0x4002_200B | 4B   |
|                                      | FLASH_STS                 | 0x4002_200C – 0x4002_200F | 4B   |
|                                      | FLASH_CTRL                | 0x4002_2010 – 0x4002_2013 | 4B   |
|                                      | FLASH_ADD                 | 0x4002_2014 – 0x4002_2017 | 4B   |
|                                      | Reserved                  | 0x4002_2018 – 0x4002_201B | 4B   |
|                                      | FLASH_OB                  | 0x4002_201C – 0x4002_201F | 4B   |
|                                      | FLASH_WRP                 | 0x4002_2020 – 0x4002_2023 | 4B   |
|                                      | FLASH_ECC                 | 0x4002_2024 – 0x4002_2027 | 4B   |
|                                      | Reserved                  | 0x4002_2028 – 0x4002_202B | 4B   |
|                                      | FLASH_RDN                 | 0x4002_202C – 0x4002_202F | 4B   |
|                                      | FLASH_CAGR                | 0x4002_2030 – 0x4002_2033 | 4B   |

Flash memory is organized into 32-bit wide memory units, which can store codes and data constants.

Information is divided into three parts:

- The system memory area is used for storing a boot program for boot loader mode of the system memory. The boot program uses USART1 and USB (DFU) serial interface to program the flash memory.
- System configuration area, which contains basic information of the chip.
- Option byte area, writing to main memory and information block is managed by embedded flash

programming/erasing controller.

There are two ways to protect flash memory from illegal access (read, write and erase):

- Page write protection (WRP)
- Read protection (RDP)

When the flash memory write operation is executed, any read operation to the flash memory will lock the bus, and the read operation can only be carried out correctly after the write operation is completed. That is, when writing or erasing, cannot have any read access to the code or data.

The internal RC oscillator (HSI) must be turned on when the flash memory is programmed (written or erased).

*Note: In the low power consumption mode, all flash memory operations are suspended.*

### 3.2.1.2 Read and write operation

The Flash operation only supports 32-bit operation, and the Flash should be erased before the write operation, and the minimum block size for erasing is one Page 2KB. Write operation is divided into programming and erasing phases.

When reading Flash, the number of waiting cycles for reading can be configured by the register. When using, it needs to be calculated in combination with the clock frequency of AHB interface. For example, when  $HCLK \leq 32\text{MHz}$ , the minimum number of waiting periods is 0; When  $32\text{MHz} < HCLK \leq 64\text{MHz}$ , the minimum number of waiting periods is 1; When  $64\text{MHz} < HCLK \leq 96\text{MHz}$ , the minimum number of waiting periods is 2; When  $96\text{MHz} < HCLK \leq 128\text{MHz}$ , the minimum number of waiting periods is 3; When  $128\text{MHz} < HCLK \leq 144\text{MHz}$ , the minimum number of waiting periods is 4.

*Note: Enable prefetch buffer whether number of wait periods is not zero can improve overall efficiency.*

### 3.2.1.3 Unlock Flash

After reset, the Flash module is protected and cannot be written into the FLASH\_CTRL register to prevent accidental operation of Flash due to electrical interference and other reasons. By writing a specific sequence of key values into the FLASH\_KEY register, you can open the operation authority of the FLASH\_CTRL register. The specific sequence is: Firstly, writing KEY1 = 0x45670123 in the FLASH\_KEY register. Secondly, write KEY2 = 0xCDEF89AB in the FLASH\_KEY register.

If there is an error in sequence or key value, a bus error will be returned and the FLASH\_CTRL register will be locked until the next reset. The software can check whether the Flash has been unlocked by looking at the FLASH\_CTRL.LOCK bit. If normal lock setting is needed, it can be realized by setting the FLASH\_CTRL.LOCK bit to 1 by software. After that, you can unlock the Flash by writing the correct key value series in FLASH\_KEY.

### 3.2.1.4 Erase and program

#### 3.2.1.4.1 Erase of main memory area

The main memory area can be erased page by page or whole.

#### Page Erase

Page Erase process:

- Check the FLASH\_STG.BUSY bit to confirm that there are no other flash operations in progress;
- Set the FLASH\_CTRL.PER bit to '1';

- Select the page to be erased with the FLASH\_ADD register;
- Set the FLASH\_CTRL.START bit to '1';
- Wait for the FLASH\_STS.BUSY bit to change to '0';
- Read out the erased page and verify it.

### Mass Erase

Mass Erase process:

- Check the FLASH\_STS.BUSY bit to confirm that there are no other flash operations in progress;
- Set the FLASH\_CTRL.MER bit to '1';
- Set the FLASH\_CTRL.START bit to '1';
- Wait for the FLASH\_STS.BUSY bit to change to '0';
- Read out all pages and verify.

#### 3.2.1.4.2 Main memory area programming

The main memory area can be programmed with 32 bits at a time. When the FLASH\_CTRL.PG bit is '1', writing a word in a flash address will start programming once; Writing any half word of data will result in a bus error. During the programming process (the FLASH\_STS.BUSY bit is '1'), any operation of reading or writing the flash memory will cause the CPU to pause until the end of the flash programming.

Main memory programming process:

- Check the FLASH\_STS.BUSY bit to confirm that there are no other flash operations in progress;
- Set the FLASH\_CTRL.PG bit to '1';
- Write the word to be programmed at the specified address;
- Wait for the FLASH\_STS.BUSY bit to change to '0';
- Read the written address and verify the data.

*Note: When the FLASH\_STS.BUSY bit is '1', you cannot write to any register.*

*Note: After writing data to two addresses in programming, it is necessary to add 5 \_\_NOP() to prevent the bus from reading Flash data and causing programming failure.*

#### 3.2.1.4.3 Option byte erase and programming

The option byte area is programmed differently from the main storage area. The number of option bytes is only 9 bytes (4 bytes for write protection, 2 bytes for read protection, 1 byte for configuration and 2 bytes for storing user data). After unlocking the Flash, you must write KEY1 and KEY2 respectively (see 3.2.1.3) to the FLASH\_OPTKEY register, and then set the FLASH\_CTRL.OPTWE bit to '1'. At this time, the option byte area can be programmed: set the FLASH\_CTRL.OPTPG bit to '1' and then write the word to the specified address.

When programming the word in the option byte area, use the low byte in the half-word and automatically calculate the high byte (the high byte is the complement of the low byte), and start the programming operation, which will ensure that the option byte and its complement are always correct.

Option byte erase process:

- Check the FLASH\_STS.BUSY bit to confirm that there are no other flash operations in progress;
- Unlock the FLASH\_CTRL.OPTWE bit;
- Set the FLASH\_CTRL.OPTER bit to '1';
- Set the FLASH\_CTRL.START bit to '1';
- Wait for the FLASH\_STS.BUSY bit to change to '0';
- Read the erased option byte and verify it.

Option byte area programming process:

- Check the FLASH\_STS.BUSY bit to confirm that there are no other flash operations in progress;
- Unlock the FLASH\_CTRL.OPTWE bit;
- Set the FLASH\_CTRL.OPTPG bit to '1';
- Writing the word to be programmed to the specified address;
- Wait for the FLASH\_STS.BUSY bit to change to '0';
- Read the written address and verify the data.

### 3.2.1.5 ECC function

The Flash module supports the ECC function to realize 1-bit error detection and 1-bit error correction. ECC encoding and decoding (error correction, error detection) are automatically performed by hardware. If an error is detected, the error bit is set and an interrupt is generated.

### 3.2.1.6 Instruction prefetching

The instruction prefetch function of Flash module supports the prefetch Buffer of 16B. Through instruction prefetching, the instruction execution efficiency of CPU can be improved. The instruction prefetch function can be configured to be enabled or disabled through the register, and it is enabled by default.

### 3.2.1.7 Option byte

Option byte block is mainly used to configure read-write protection, boot mode configuration, software/hardware watchdog configuration and reset options when the system is in standby/stop0/stop2 mode, and bus address space is allocated for read-write access. They consist of byte with 9 options: 4 byte for write protection, 2 bytes for read protection, 1 byte for configuration option, 2 bytes defined by user, These 9 bytes need to be written through the bus. The option byte block also contains the complement codes corresponding to these 9 option bytes. These complement codes need to be automatically calculated by hardware when the option bytes are written in the bus, and written into Flash together, and used for verification when the option bytes are read.

By default, the option byte block is always readable and write-protected. To write (program/erase) the option byte block, first unlock the Flash, then unlock the option byte: write the correct key-value sequence (KEY1 = 0x45670123, KEY2 = 0xCDEF89AB) in the FLASH\_OPTKEY, and then write the option byte block will be allowed. If the sequence is wrong or the key value is wrong, a bus error will be returned and the option byte will be locked until the next reset. If it is necessary to set the lock normally, it can be realized by writing 0 to the FLASH\_CTRL.OPTWE bit by software, and then the option byte can be unlocked by writing the correct key-value series in the FLASH\_OPTKEY.

After each system reset, the option byte data is read out from the option byte block of Flash and stored in the option

byte register (FLASH\_OB/FLASH\_WRP) with read-only property. At the same time, the option byte complement data read out together will be used to verify whether the option byte data is correct. If it does not match, an option byte error flag (FLASH\_OB.OBERR) will be generated. When an option byte error occurs, the corresponding option byte is forced to 0xFF. When the option byte and its complement are both 0xFF (the state after erasing), the above verification steps are skipped and verification is not required.

Table 3-3 Option byte list

| Address     | [31:24]<br>Corresponding<br>complement code | [23:16]<br>Option byte | [15:8]<br>Corresponding<br>complement code | [7:0]<br>Option byte |
|-------------|---|------------------------|--|----------------------|
| 0x1FFF_F800 | nUSER                                       | USER                   | nRDP1                                      | RDP1                 |
| 0x1FFF_F804 | nData1                                      | Data1                  | nData0                                     | Data0                |
| 0x1FFF_F808 | nWRP1                                       | WRP1                   | nWRP0                                      | WRP0                 |
| 0x1FFF_F80C | nWRP3                                       | WRP3                   | nWRP2                                      | WRP2                 |
| 0x1FFF_F810 | -   | -                      | nRDP2                                      | RDP2                 |

- Read protection L1 level option byte: RDP1
  - ◆ Protect the code stored in the flash memory;
  - ◆ When the correct value is written, it will be forbidden to read the flash memory;
  - ◆ The result of whether RDP1 is turned on or not can be inquired through FLASH\_OB[1];
- User configuration options: USER
  - ◆ USER[7:3]: Reserved
  - ◆ USER[2]: nRST\_STDBY configuration options, read through FLASH\_OB [4]
    - 0: Reset when entering standby mode
    - 1: No reset occurs when entering standby mode
  - ◆ USER[1]: nRST\_STOP, read through FLASH\_OB[3]
    - 0: Reset occurs when entering stop0/stop2 mode
    - 1: No reset occurs when entering stop0/stop2 mode
  - ◆ USER[0]: WDG\_SW configuration options, read through FLASH\_OB [2]
    - 0: Hardware watchdog
    - 1: Software watchdog
- 2 bytes of user data: Datax
  - ◆ Data1 (stored in FLASH\_OB[25:18]);
  - ◆ Data0 (stored in FLASH\_OB [17:10]);
- Write protection option byte: WRP0 ~ 3, which can be written through the register FLASH\_WRP [31:0] query
  - ◆ WRP0: write protection of pages 0-15, bit [0] corresponds to Page0 / 1,, bit [7] corresponds to page14 / 15;

- ◆ WRP1: write protection on pages 16-31, bit [0] corresponds to Page16 / 17,.., bit [7] corresponds to Page30 / 31;
- ◆ WRP2: write protection on pages 32-47 bit [0] corresponds to Page32 / 33,.., bit [7] corresponds to Page46 / 47;
- ◆ WRP3: write protection on pages 48-255, bit [0] corresponds to Page48 /49., bit [6] corresponds to Page60 / 61, bit [7] corresponds to Page62 / 255;
- Read protection L2 level option byte: RDP2
  - ◆ Add protection function on the basis of L1, see 3.2.1.9 detailed description of read protection;
  - ◆ Whether RDP2 is turned on or not can be determined by FLASH\_OB [31] query;

### 3.2.1.8 Write protect

Write protection can be configured for all pages in the flash main storage area (maximum 512KB) to prevent accidental write operations caused by program runaway or electrical interference. The basic unit of write protection is: for Page0 ~ 61, every 2 pages is a basic protection unit, for Page62~255, together as a protection unit. Write protection can be configured by setting WRP0 ~ 3 in the option byte block; After each configuration, A system reset is required for the configured value to be reloaded to take effect. If an attempt is made to program or erase a protected page, a protection error flag will be returned in the FLASH\_STS.

The system memory block (16KB) in the system information area stores the boot program and cannot be changed.

The system configuration block (2KB) in the system information area stores the basic information of the chip and cannot be changed.

The option byte block (2KB) in the system information area stores the user-configurable option byte information. The write protection of the option byte block is achieved by writing 0 to the FLASH\_CTRL.OPTWE bit by software, and after that, you can write the correct key value series in FLASH\_OPTKEY to release the write protection of the option byte.

### 3.2.1.9 Read protection

The user code in flash can be protected from illegal reading by setting read protection. Read protection is mainly aimed at protecting the access operation of main memory area and option byte block after chip sealing operation. Read protection is set by configuring RDP bytes in the option byte block. Three different read protection levels can be configured, as shown in the following Table

Table 3-4 Read protection configuration list

| Read protection status | RDP1                               | nRDP1 | nRDP2                         | RDP2 |
|------------------------|------------------------------------|-------|-------------------------------|------|
| L0 level               | 0xA5                               | 0x5A  | RDP2! = 0xCC    nRDP2! = 0x33 |      |
| L2 level               | 0xFF                               | 0xFF  | 0x33                          | 0xCC |
| L1 level               | Not the above three configurations |       |                               |      |

- L0 level:
  - ◆ In unprotected state, corresponding (RDP1 == 0xA5 & nRDP1 == 0x5A) && (RDP2!= 0xCC | nRDP2!= 0x33);
  - ◆ The main memory area and option byte block can be read arbitrarily;

- ◆ The write protection property of each page can be configured for programming and erasing;
- L1 level:
  - ◆ The corresponding  $\sim (((RDP1 == 0xA5 \ \& \ nRDP1 == 0x5A) \ \&\& \ (RDP2 != 0xCC \ | \ nRDP2 != 0x33)) \ | \ (RDP2 == 0xCC \ \& \ nRDP2 == 0x33))$ ;
  - ◆ Only the read operation of the main storage area from the user code is allowed, that is, when the program is started from the main flash memory in non debugging mode, the read operation of the main storage area is allowed;
  - ◆ Pages 0~1 are automatically write-protected;
  - ◆ Other pages can be programmed by the code executed in the main flash memory (realizing IAP or data storage and other functions);
  - ◆ All pages are not allowed to write or erase in debug mode or after booting from internal SRAM (except for mass erase);
  - ◆ All functions of loading code into the built-in SRAM through JTAG/SWD and then execute it are still valid, or they can be started from the built-in SRAM through JTAG/SWD, which can be used to remove read protection;
  - ◆ When the read-protected option byte is rewritten to the unprotected L0 level, all the main storage areas will be automatically erased, and the process is as follows: (Erasing the option byte block will not result in automatic whole erasing operation, because the result of erasing is 0xFF, which is equivalent to still being in the protection state of L1 level)
    - Write the correct key value sequence to unlock the option byte area in FLASH\_OPTKEY;
    - The bus initiates a command to erase the entire option byte area (Page erase);
    - Bus write 0xA5 to read protection option byte;
    - Automatically erase all main storage areas internally;
    - Automatically write 0xA5 to read protection option byte internally;
    - When the system is reset (such as software reset, etc.), the option byte block (including the new RDP value 0xA5) will be reloaded into the system, and the read protection will be released;
  - ◆ The following access operations to the flash memory will be prohibited:
    - Access main flash memory from built-in SRAM start execution code (including using DMA);
    - Access the main flash memory by JTAG, SWV (serial line observer), SWD (serial line debugging) and boundary scanning;
- L2 level: Except that SRAM boot disabled, debug mode disabled, option byte write/page erase disabled and the protection level cannot be modified (irreversible), other features are the same as L1 level. The L2 level is realized by configuring another option byte, RDP2. No matter what the value of RDP1 is, as long as it satisfies  $(RDP2 == 0xCC \ \& \ nRDP2 == 0x33)$ , it is L2 level.

 Table 3-5 Flash read-write-erase <sup>(1)</sup> permission control table

|         |           |            |                       |
|---------|-----------|------------|-----------------------|
| protect | Boot mode | Main Flash | Changing a Protection |
|---------|-----------|------------|-----------------------|

| level       | Perform user<br>Access area             | JTAG/<br>SWD                          | Mian Flash           | System Memory    | SRAM                 | Level   |
|-------------|---|---------------------------------------|----------------------|------------------|----------------------|---|
| L0<br>level | Before 4KB of flash<br>main memory area | Read-Write-<br>Erase                  | Read-Write-<br>Erase | Read-Write-Erase | Read-Write-<br>Erase | Change to L1 or L2 is<br>allowed  |
|             | After 4KB of flash<br>main memory area  | Read-Write-<br>Erase                  | Read-Write-<br>Erase | Read-Write-Erase | Read-Write-<br>Erase |   |
|             | Flash main memory<br>area mass erase    | Allow                                 | Allow                | Allow            | Allow                |   |
|             | Flash option byte area                  | Read-Write-<br>Erase                  | Read-Write-<br>Erase | Read-Write-Erase | Read-Write-<br>Erase |   |
|             | Flash system memory<br>area             | prohibit                              | prohibit             | Read-Write-Erase | prohibit             |   |
|             | SRAM (All)                              | Read and<br>write                     | Read and<br>write    | Read and write   | Read and<br>write    |   |
| L1<br>level | Before 4KB of flash<br>main memory area | Prohibit                              | Read-only            | Read-only        | Read-only            | L0 or L2 is allowed.<br>When changed to L0,<br>the main memory area<br>is automatically erased. |
|             | After 4KB of flash<br>main memory area  | Prohibit                              | Read-Write-<br>Erase | Read-Write-Erase | Read-Write-<br>Erase |   |
|             | Flash main memory<br>area mass erase    | Allow                                 | Allow                | Allow            | Allow                |   |
|             | Flash option byte area                  | Read-Write-<br>Erase                  | Read-Write-<br>Erase | Read-Write-Erase | Read-Write-<br>Erase |   |
|             | Flash system memory<br>area             | Prohibit                              | Prohibit             | Read-write-erase | Prohibit             |   |
|             | SRAM (All)                              | Read and<br>write                     | Read and<br>write    | Read and write   | Read and<br>write    |   |
| L2<br>level | Before 4KB of flash<br>main memory area | JTAG/SWD<br>interface is<br>disabled. | Read-only            | Read-only        | Read-only            | No modification is<br>allowed.  |
|             | After 4KB of flash<br>main memory area  |                                       | Read-write-<br>erase | Read-write-erase | Read-write-<br>erase |   |

|               |                                      |                  |                  |                  |                  |   |
|---------------|--------------------------------------|------------------|------------------|------------------|------------------|---|
|               | Flash main memory area mass erase    |                  | Allow            | Allow            | Allow            |   |
|               | Flash option byte area               |                  | Read-only        | Read-only        | Read-only        |   |
|               | Flash system memory area             |                  | Prohibit         | Read-write-erase | Prohibit         |   |
|               | SRAM (All)                           |                  | Read and write   | Read and write   | Read and write   |   |
|               |                                      |                  |                  |                  |                  |   |
| protect level | Boot mode                            | SRAM             |                  |                  |                  | Changing a Protection Level   |
|               | Perform user Access to areas         | JTAG/SWD         | Main Flash       | System Memory    | SRAM             |   |
| L0 level      | Before 4KB of flash main memory area | Read-write-erase | Read-write-erase | Read-write-erase | Read-write-erase | Change to L1 or L2 is allowed   |
|               | After 4KB of flash main memory area  | Read-write-erase | Read-write-erase | Read-write-erase | Read-write-erase |   |
|               | Flash main memory area mass erase    | Allow            | Allow            | Allow            | Allow            |   |
|               | Flash option byte area               | Read-write-erase | Read-write-erase | Read-write-erase | Read-write-erase |   |
|               | Flash system memory area             | Prohibit         | Prohibit         | Read-write-erase | Prohibit         |   |
|               | SRAM (All)                           | Read and write   | Read and write   | Read and write   | Read and write   |   |
| L1 level      | Before 4KB of flash main memory area | Prohibit         | Read-only        | Read-only        | Prohibit         | L0 or L2 is allowed.<br>When changed to L0, the main memory area is automatically erased. |
|               | After 4KB of flash main memory area  | Prohibit         | Read-write-erase | Read-write-erase | Prohibit         |   |
|               | Flash main memory area mass erase    | Allow            | Allow            | Allow            | Allow            |   |

|               |                                      |  |                  |                  |                  |  |
|---------------|--------------------------------------|--|------------------|------------------|------------------|--|
|               | Flash option byte area               | Read-write-erase                           | Read-write-erase | Read-write-erase | Read-write-erase |  |
|               | Flash system memory area             | Prohibit                                   | Prohibit         | Prohibit         | Prohibit         |  |
|               | SRAM (All)                           | Read and write                             | Read and write   | Read and write   | Read and write   |  |
| L2 level      | Before 4KB of flash main memory area | L2 protection level, cannot boot from SRAM |                  |                  |                  | No modification is allowed.<br>JTAG/SWD is banned. |
|               | After 4KB of flash main memory area  |  |                  |                  |                  |  |
|               | Flash main memory area mass erase    |  |                  |                  |                  |  |
|               | Flash option byte area               |  |                  |                  |                  |  |
|               | Flash system memory area             |  |                  |                  |                  |  |
|               | SRAM (All)                           |  |                  |                  |                  |  |
|               |                                      |  |                  |                  |                  |  |
| protect level | Boot mode                            | System Memory                              |                  |                  |                  | Changing a Protection Level                        |
|               | Perform user<br>Access to areas      | JTAG/SWD                                   | Main Flash       | System Memory    | SRAM             |  |
| L0 level      | Before 4KB of flash main memory area | Read-write-erase                           | Read-write-erase | Read-write-erase | Read-write-erase | Change to L1 or L2 is allowed                      |
|               | After 4KB of flash main memory area  | Read-write-erase                           | Read-write-erase | Read-write-erase | Read-write-erase |  |
|               | Flash main memory area mass erase    | Allow                                      | Allow            | Allow            | Allow            |  |
|               | Flash option byte area               | Read-write-                                | Read-write-      | Read-write-erase | Read-write-      |  |

|          |                                      |                                 |                  |                  |                  |  |
|----------|--------------------------------------|---------------------------------|------------------|------------------|------------------|--|
|          |                                      | erase                           | erase            |                  | erase            |  |
|          | Flash system memory area             | Prohibit                        | Prohibit         | Read-write-erase | Prohibit         |  |
|          | SRAM (All)                           | Read and write                  | Read and write   | Read and write   | Read and write   |  |
| L1 level | Before 4KB of flash main memory area | Prohibit                        | Read-only        | Read-only        | Read-only        | L0 or L2 is allowed. When changed to L0, the main memory area is automatically erased. |
|          | After 4KB of flash main memory area  | Prohibit                        | Read-write-erase | Read-write-erase | Read-write-erase |  |
|          | Flash main memory area mass erase    | Allow                           | Allow            | Allow            | Allow            |  |
|          | Flash option byte area               | Read-write-erase                | Read-write-erase | Read-write-erase | Read-write-erase |  |
|          | Flash system memory area             | Prohibit                        | Prohibit         | Read-write-erase | Prohibit         |  |
|          | SRAM (All)                           | Read and write                  | Read and write   | Read and write   | Read and write   |  |
| L2 level | Before 4KB of flash main memory area | JTAG/SWD interface is disabled. | Read-only        | Read-only        | Read-only        | No modification allowed  |
|          | After 4KB of flash main memory area  |                                 | Read-write-erase | Read-write-erase | Read-write-erase |  |
|          | Flash main memory area mass erase    |                                 | Allow            | Allow            | Allow            |  |
|          | Flash option byte area               |                                 | Read-only        | Read-only        | Read-only        |  |
|          | Flash system memory area             |                                 | Prohibit         | Read-write-erase | Prohibit         |  |
|          | SRAM (All)                           |                                 | Read and write   | Read and write   | Read and write   |  |

Note: 1. Erase here refers to flash page erase.

### 3.2.2 iCache

In order to achieve higher system performance, an instruction buffer needs to be added between the high-speed CPU and the low-speed Flash to improve the instruction execution efficiency. Because of the existence of the instruction buffer, the CPU will be able to work at a higher frequency. When the instruction requested by the CPU is in the instruction buffer, the CPU can obtain the instruction without delay and realize zero waiting for execution. When the current instruction sequence, instruction prefetch sequence and instruction buffer all miss, Flash will be re-read and the Cache will be backfilled and updated. Accordingly, it is equivalent to storing only the jump header of the program in the Cache.

The main features of the instruction buffer are as follows:

- 8KB iCache.
- Support connection mode: 4WAY.

#### 3.2.2.1 Software interface

- Enable
  - ◆ Provide configuration for software to enable/disable iCache. There is no limit to the switching conditions (see the FLASH\_AC.ICAHEN bit).
- Reset
  - ◆ Provide software to clear the iCache interface, which must be initiated when iCache is closed. Reset and switching cannot be switched at the same time. First, turn off FLASH\_AC.ICAHEN, then write 1 to FLASH\_AC.ICAHRST, and then turn on FLASH\_AC.ICAHEN.
- Lock
  - ◆ Cache locking mechanism is supported, and the software configuration puts the program into its designated way. When all the ways are locked, the new data will not be written into the cache. After the software resets the cache, the lock state is automatically cleared.
- Additional remarks
  - ◆ Selection of Cache replacement algorithm is not supported.
  - ◆ When using icache, there is no WB/WT selection when the CPU writes operation.

#### 3.2.2.2 Register description

FLASH\_AC.ICAHEN and FLASH\_AC.ICAHRST are the iCache enable switch and iCache data clear switch respectively.

FLASH\_CAHR.LOCKSTRT and FLASH\_CAHR.LOCKSTOP are the start latch and stop latch of iCache corresponding mode lock, respectively. After iCache is reset, the FLASH\_CAHR register automatically returns to the reset value. See for detailed usage method of 3.2.2.3.3 iCache locking.

#### 3.2.2.3 Operating process

##### 3.2.2.3.1 iCache enable and disable

Users can turn on and switch off iCache at any time. If the user program needs to jump between the main memory area and other memory areas, the iCache must be closed and the data of the iCache must be cleared, otherwise, the

instruction acquisition error will occur.

### 3.2.2.3.2 iCache data refresh

The iCache is designed as instruction cache. When the instruction is updated by application software or the instruction jumps between the main memory area and other memory areas, the software must set the FLASH\_AC.ICAHRST bit to 1 to clear the data in the instruction cache.

*Note: FLASH\_AC.ICAHRST bit is a write-only bit, and it returns to 0 when read.*

### 3.2.2.3.3 iCache locking

The software controls the FLASH\_CAHR register to lock some repeatedly used codes in iCache to improve the efficiency of code execution. iCache module has four latch channels, and the size of each channel is 1/4 of the whole cache. When using a single channel, you must ensure that the amount of code to latch is less than the size of each channel. Otherwise need to use more channels to latch the code. The latch function can be used according to the following control flow:

1. Set FLASH\_CAHR.LOCKSTRT[0] to 1;
2. Execute function 1 that needs to be locked in channel 0 (the code amount of function 1 should be less than the size of a single channel);
3. Set FLASH\_CAHR.LOCKSTOP[0] to 1 after the function 1 is executed;
4. Then set FLASH\_CAHR.LOCKSTRT[1] to 1;
5. Execute function 2 that needs to be locked in channel 1 (the code amount of function 2 should be less than the size of a single channel);
6. After the function 2 is executed, set FLASH\_CAHR.LOCKSTOP[1] to 1;

*Attention: 1. when the channel is latched, the register operation must follow a fixed process -First set FLASH\_CAHR.LOCKSTRT then set FLASH\_CAHR.LOCKSTOP;*

*2. The order of channel latch must be 0~3, otherwise it will reduce the execution efficiency.*

*3. If the writing or erasing of Flash involves certain data in the instruction cache, it is recommended to refresh the instruction cache by setting FLASH\_AC.ICAHRSTx in the control register (FLASH\_AC) before accessing Flash.*

## 3.2.3 SRAM

SRAM is mainly used for code operation to store variables and data or stacks during program execution. The maximum capacity is 128KB.

SRAM supports read-write access of byte, half-word and word.

SRAM supports code running (supports access of SBus, ICode and DCode), and can run programs at full speed in SRAM. The maximum address range of SRAM is 0x2000 0000~0x2001 FFFF.

SRAM data cannot be retained in Stop2, Standby and VBAT modes; data in other working modes (Run/Sleep/Stop0) can be retained normally.

The main features are as follows:

- The maximum capacity is 128KB in total.

- Support byte/half-word/word reading and writing
- I/D/S/DMA1/MDA2/ETH can be accessed.
- I/D BUS can run programs at full speed from Remap to SRAM.

### 3.2.4 R-SRAM (Retention SRAM)

R-SRAM is also mainly used for code operation, storing variables and data or stacks during program execution, with a total capacity of 16KB. The bus address of R-SRAM and SRAM are connected continuously. In application, SRAM and R-SRAM can be treated as a piece of SRAM. In the maximum case, the physical address of R-SRAM No.0 corresponds to the bus start address of 0x2002 0000, and the corresponding bus address range is 0x2002 0000~0x2002 3FFF. R-SRAM supports read and write access of bytes, half words and words, and supports access to SBus, DMA1, DMA2, and ETH.

Because the bus address of R-SRAM is continuously connected to SRAM, and for different product models, the capacity of SRAM available for effective use is different, so for different product models, the bus start address of R-SRAM are different.

R-SRAM supports Retention, which can retain data in VBAT and Standby modes (can be configured to retain or not retain); other working modes (RUN/SLEEP/STOP0/STOP2) data can be retained by default; PWR is required to control and manage its Retention.

Table 3-6 SRAM Capacity Configuration Table

| SRAM capacity | R-SRAM capacity | SRAM bus address range  | R-SRAM bus address range |
|---------------|-----------------|-------------------------|--------------------------|
| 64KB          | 16KB            | 0x2000 0000~0x2000 FFFF | 0x2001 0000~0x2001 3FFF  |
| 128KB         | 16KB            | 0x2000 0000~0x2001 FFFF | 0x2002 0000~0x2002 3FFF  |

The main features of R-SRAM are as follows:

- The total capacity is 16KB(Supports parity check and needs to be initialized before use)
- Byte/halfword/word read and write
- SBus/DMA1/DMA2/ETH can be accessed
- The bus start address is continuously connected to the main memory SRAM
- The bus start address changes with the main memory SRAM capacity
- Retention is possible, data still needs to be retained in stop2 and standby modes (can be configured not to retain)

### 3.2.5 FLASH register

These peripheral registers must be operated as words (32 bits).

#### 3.2.5.1 FLASH register overview

Table 3-7 FLASH register overview

| Offset | Register | 31       | 30 | 29 | 28 | 27 | 26 | 25 | 24 | 23 | 22 | 21 | 20 | 19 | 18 | 17 | 16 | 15 | 14 | 13 | 12 | 11 | 10 | 9 | 8 | 7      | 6        | 5       | 4       | 3        | 2       | 1 | 0 |  |  |  |  |  |  |  |  |  |  |  |  |  |  |  |  |  |  |  |  |  |  |
|--------|----------|----------|----|----|----|----|----|----|----|----|----|----|----|----|----|----|----|----|----|----|----|----|----|---|---|--------|----------|---------|---------|----------|---------|---|---|--|--|--|--|--|--|--|--|--|--|--|--|--|--|--|--|--|--|--|--|--|--|
| 000h   | FLASH_AC | Reserved |    |    |    |    |    |    |    |    |    |    |    |    |    |    |    |    |    |    |    |    |    |   |   | ICAHEN | ICAHIRST | PRFTBFS | PRFTBFE | Reserved | LATENCY |   |   |  |  |  |  |  |  |  |  |  |  |  |  |  |  |  |  |  |  |  |  |  |  |

| Offset | Register     | 31       | 30       | 29 | 28 | 27 | 26 | 25 | 24 | 23         | 22    | 21 | 20 | 19 | 18 | 17 | 16 | 15       | 14    | 13    | 12 | 11        | 10     | 9       | 8      | 7          | 6        | 5    | 4      | 3        | 2          | 1         | 0      |        |       |   |   |   |   |   |   |   |   |   |   |   |   |   |   |   |   |   |   |
|--------|--------------|----------|----------|----|----|----|----|----|----|------------|-------|----|----|----|----|----|----|----------|-------|-------|----|-----------|--------|---------|--------|------------|----------|------|--------|----------|------------|-----------|--------|--------|-------|---|---|---|---|---|---|---|---|---|---|---|---|---|---|---|---|---|---|
|        | Reset Value  |          |          |    |    |    |    |    |    |            |       |    |    |    |    |    |    |          |       |       |    |           |        |         |        | 0          | 0        | 1    | 1      |          | 0          | 0         | 0      |        |       |   |   |   |   |   |   |   |   |   |   |   |   |   |   |   |   |   |   |
| 004h   | FLASH_KEY    | FKEY     |          |    |    |    |    |    |    |            |       |    |    |    |    |    |    |          |       |       |    |           |        |         |        |            |          |      |        |          |            |           |        |        |       |   |   |   |   |   |   |   |   |   |   |   |   |   |   |   |   |   |   |
|        | Reset Value  | 0        | 0        | 0  | 0  | 0  | 0  | 0  | 0  | 0          | 0     | 0  | 0  | 0  | 0  | 0  | 0  | 0        | 0     | 0     | 0  | 0         | 0      | 0       | 0      | 0          | 0        | 0    | 0      | 0        | 0          | 0         |        |        |       |   |   |   |   |   |   |   |   |   |   |   |   |   |   |   |   |   |   |
| 008h   | FLASH_OPTKEY | OPTKEY   |          |    |    |    |    |    |    |            |       |    |    |    |    |    |    |          |       |       |    |           |        |         |        |            |          |      |        |          |            |           |        |        |       |   |   |   |   |   |   |   |   |   |   |   |   |   |   |   |   |   |   |
|        | Reset Value  | 0        | 0        | 0  | 0  | 0  | 0  | 0  | 0  | 0          | 0     | 0  | 0  | 0  | 0  | 0  | 0  | 0        | 0     | 0     | 0  | 0         | 0      | 0       | 0      | 0          | 0        | 0    | 0      | 0        | 0          | 0         |        |        |       |   |   |   |   |   |   |   |   |   |   |   |   |   |   |   |   |   |   |
| 00Ch   | FLASH_STS    | Reserved |          |    |    |    |    |    |    |            |       |    |    |    |    |    |    |          |       |       |    |           |        |         |        | ECCERR     | EVERR    | EOP  | WRPERR | PVERR    | PGERR      | RDKEYERR  | BUSY   |        |       |   |   |   |   |   |   |   |   |   |   |   |   |   |   |   |   |   |   |
|        | Reset Value  |          |          |    |    |    |    |    |    |            |       |    |    |    |    |    |    |          |       |       |    |           |        |         |        | 0          | 0        | 0    | 0      | 0        | 0          | 0         | 0      |        |       |   |   |   |   |   |   |   |   |   |   |   |   |   |   |   |   |   |   |
| 010h   | FLASH_CTRL   | Reserved |          |    |    |    |    |    |    |            |       |    |    |    |    |    |    |          |       |       |    | ECCERRITE | EOPTIE | FERRITE | ERRITE | OPTWE      | SMPSEL   | LOCK | START  | OPTER    | OPTPG      | Reserved  | MER    | PER    | PG    |   |   |   |   |   |   |   |   |   |   |   |   |   |   |   |   |   |   |
|        | Reset Value  |          |          |    |    |    |    |    |    |            |       |    |    |    |    |    |    |          |       |       |    | 0         | 0      | 0       | 0      | 0          | 0        | 1    | 0      | 0        | 0          |           | 0      | 0      | 0     |   |   |   |   |   |   |   |   |   |   |   |   |   |   |   |   |   |   |
| 014h   | FLASH_ADD    | FADD     |          |    |    |    |    |    |    |            |       |    |    |    |    |    |    |          |       |       |    |           |        |         |        |            |          |      |        |          |            |           |        |        |       |   |   |   |   |   |   |   |   |   |   |   |   |   |   |   |   |   |   |
|        | Reset Value  | 0        | 0        | 0  | 0  | 0  | 0  | 0  | 0  | 0          | 0     | 0  | 0  | 0  | 0  | 0  | 0  | 0        | 0     | 0     | 0  | 0         | 0      | 0       | 0      | 0          | 0        | 0    | 0      | 0        | 0          |           |        |        |       |   |   |   |   |   |   |   |   |   |   |   |   |   |   |   |   |   |   |
| 018h   | Reserved     |          |          |    |    |    |    |    |    |            |       |    |    |    |    |    |    |          |       |       |    |           |        |         |        |            |          |      |        |          |            |           |        |        |       |   |   |   |   |   |   |   |   |   |   |   |   |   |   |   |   |   |   |
| 01Ch   | FLASH_OB     | RDPRT2   | Reserved |    |    |    |    |    |    |            | Data1 |    |    |    |    |    |    |          | Data0 |       |    |           |        |         |        |            | Not Used |      |        |          | nRST_STDBY | nRST_STOP | WDG_SW | RDPRT1 | OBERR |   |   |   |   |   |   |   |   |   |   |   |   |   |   |   |   |   |   |
|        | Reset Value  | 0        |          |    |    |    |    |    |    |            | 1     | 1  | 1  | 1  | 1  | 1  | 1  | 1        | 1     | 1     | 1  | 1         | 1      | 1       | 1      | 1          | 1        | 1    | 1      | 1        | 1          | 1         | 1      | 1      | 1     | 1 | 0 | 0 |   |   |   |   |   |   |   |   |   |   |   |   |   |   |   |
| 020h   | FLASH_WRP    | WRPT     |          |    |    |    |    |    |    |            |       |    |    |    |    |    |    |          |       |       |    |           |        |         |        |            |          |      |        |          |            |           |        |        |       |   |   |   |   |   |   |   |   |   |   |   |   |   |   |   |   |   |   |
|        | Reset Value  | 1        | 1        | 1  | 1  | 1  | 1  | 1  | 1  | 1          | 1     | 1  | 1  | 1  | 1  | 1  | 1  | 1        | 1     | 1     | 1  | 1         | 1      | 1       | 1      | 1          | 1        | 1    | 1      | 1        | 1          | 1         | 1      |        |       |   |   |   |   |   |   |   |   |   |   |   |   |   |   |   |   |   |   |
| 024h   | FLASH_ECC    | Reserved |          |    |    |    |    |    |    |            |       |    |    |    |    |    |    |          |       | ECCHW |    |           |        |         |        | Reserved   | ECCLW    |      |        |          |            |           |        |        |       |   |   |   |   |   |   |   |   |   |   |   |   |   |   |   |   |   |   |
|        | Reset Value  |          |          |    |    |    |    |    |    |            |       |    |    |    |    |    |    |          |       | 0     | 0  | 0         | 0      | 0       | 0      | 0          | 0        | 0    | 0      | 0        | 0          | 0         | 0      | 0      | 0     | 0 | 0 | 0 | 0 | 0 | 0 | 0 |   |   |   |   |   |   |   |   |   |   |   |
| 028h   | Reserved     |          |          |    |    |    |    |    |    |            |       |    |    |    |    |    |    |          |       |       |    |           |        |         |        |            |          |      |        |          |            |           |        |        |       |   |   |   |   |   |   |   |   |   |   |   |   |   |   |   |   |   |   |
| 02Ch   | FLASH_RDN    | Reserved |          |    |    |    |    |    |    | FLASH_RDN1 |       |    |    |    |    |    |    | Reserved |       |       |    |           |        |         |        | FLASH_RDN0 |          |      |        |          |            |           |        |        |       |   |   |   |   |   |   |   |   |   |   |   |   |   |   |   |   |   |   |
|        | Reset Value  |          |          |    |    |    |    |    |    | 0          | 0     | 0  | 0  | 0  | 0  | 0  | 0  | 0        | 0     | 0     | 0  | 0         | 0      | 0       | 0      | 0          | 0        | 0    | 0      | 0        | 0          | 0         | 0      | 0      | 0     | 0 | 0 | 0 |   |   |   |   |   |   |   |   |   |   |   |   |   |   |   |
| 030h   | FLASH_CAH    | Reserved |          |    |    |    |    |    |    |            |       |    |    |    |    |    |    |          |       |       |    |           |        |         |        | LOCKSTOP   |          |      |        | LOCKSTRT |            |           |        |        |       |   |   |   |   |   |   |   |   |   |   |   |   |   |   |   |   |   |   |
|        | Reset Value  |          |          |    |    |    |    |    |    |            |       |    |    |    |    |    |    |          |       |       |    |           |        |         |        | 0          | 0        | 0    | 0      | 0        | 0          | 0         | 0      | 0      | 0     | 0 | 0 | 0 | 0 | 0 | 0 | 0 | 0 | 0 | 0 | 0 | 0 | 0 | 0 | 0 | 0 | 0 | 0 |

### 3.2.5.2 FLASH control and status register

See for abbreviations in register descriptions 1.1 section.

#### 3.2.5.2.1 The FLASH access control register (FLASH\_AC)

Address offset: 0x00

Reset value: 0x0000 0030

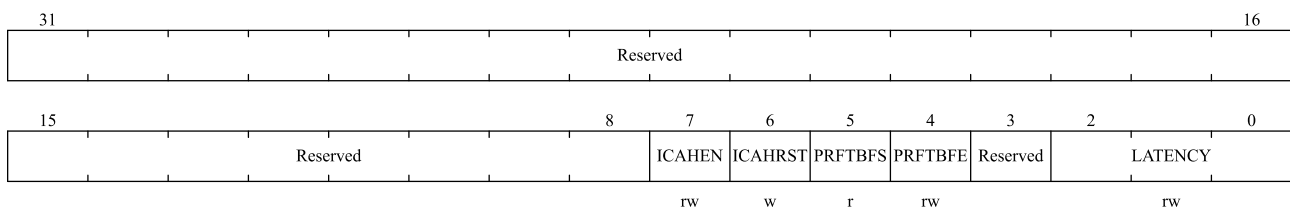

| Bit field | Name     | Description  |
|-----------|----------|--|
| 31:8      | Reserved | Reserved, the reset value must be maintained.  |
| 7         | ICAHEN   | iCache enable<br>0: turn off iCache;<br>1: enable iCache.  |
| 6         | ICAHNST  | iCache reset<br>0: writing '0' is invalid;<br>1: write '1' to reset.   |
| 5         | PRFTBFS  | Prefetch buffer status<br>This bit indicates the status of the prefetch buffer<br>0: The prefetch buffer is closed;<br>1: The prefetch buffer is open.   |
| 4         | PRFTBFE  | Prefetch buffer enable<br>0: Close the prefetch buffer;<br>1: Enable prefetch buffer.  |
| 3         | Reserved | Reserved, the reset value must be maintained.  |
| 2:0       | LATENCY  | time delay<br>These bits represent the ratio of SYSCLK (system clock) period to flash memory access time.<br><br>000: zero period delay, when 0 < SYSCLK <=32MHz<br>001: one cycle delay, when 32MHz < SYSCLK <=64MHz<br>010: two cycle delay, when 64MHz < SYSCLK <=96MHz<br>011: three cycle delay, when 96MHz < SYSCLK <= 128MHz<br>100: four cycle delay, when 128MHz < SYSCLK <= 144MHz<br><br>Other values: reserved |

### 3.2.5.2.2 The FLASH key register (FLASH\_KEY)

Address offset: 0x04

Reset value: 0xXXXX XXXX

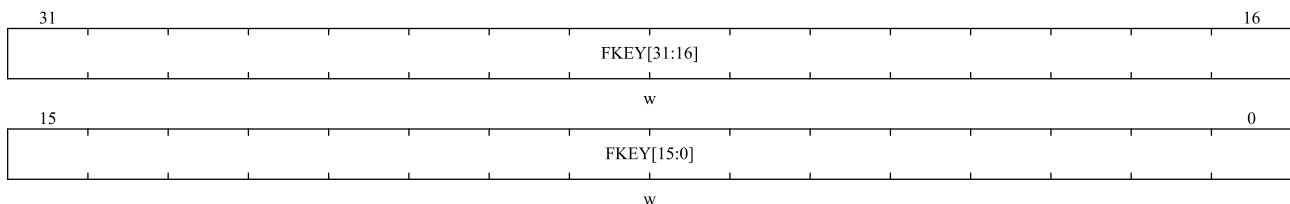

| Bit field | Name | Description                             |
|-----------|------|---|
| 31:0      | FKEY | Used to unlock the FLASH_CTRL.LOCK bit. |

### 3.2.5.2.3 The FLASH OPTKEY register (FLASH\_OPTKEY)

Address offset: 0x08

Reset value: 0xXXXX XXXX

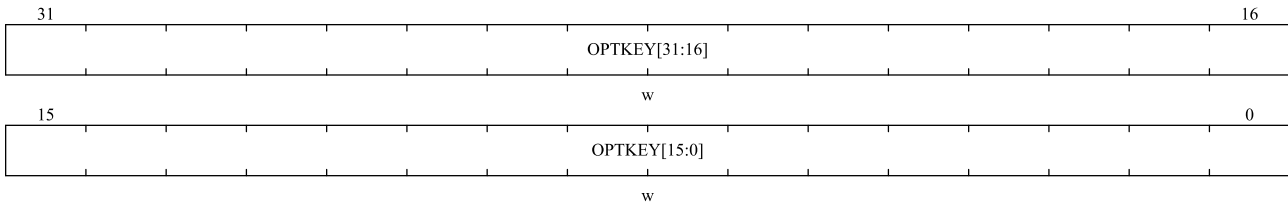

| Bit field | Name   | Description                              |
|-----------|--------|--|
| 31:0      | OPTKEY | Used to unlock the FLASH_CTRL.OPTWE bit. |

### 3.2.5.2.4 The FLASH status register (FLASH\_STS)

Address offset: 0x0C

Reset value: 0x0000 0000

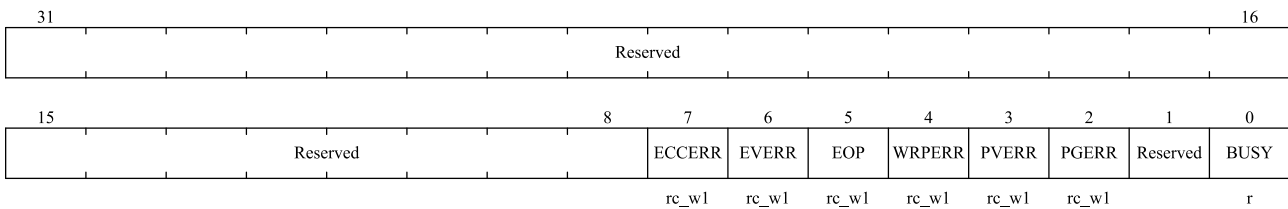

| Bit field | Name     | Description   |
|-----------|----------|---|
| 31:8      | Reserved | Reserved, the reset value must be maintained.   |
| 7         | ECCERR   | ECC error<br>Read FLASH error, hardware set this bit to '1', write '1' to clear this state.   |
| 6         | EVERR    | Erase check error<br>When the page is erased and the check reports an error, the hardware sets this bit to '1', and writing '1' can clear this state.   |
| 5         | EOP      | End of operation<br>When the flash operation (programming/erasing) is completed, the hardware sets this bit to '1', and writing '1' can clear this bit status.<br><i>Note: Every successful programming or erasing will set the EOP state.</i>    |
| 4         | WRPERR   | Write protection error<br>When trying to program a write-protected flash address, the hardware sets this bit to '1', and writing '1' can clear this bit.  |
| 3         | PVERR    | programming verification error<br>When an error is reported during verification after programming, the hardware sets this bit to '1', and writing '1' can clear this state.   |
| 2         | PGERR    | Programming error<br>When trying to program an address whose content is not '0xFFFF_FFFF', the hardware sets this bit to '1', and writing '1' can clear this state.<br><i>Note: Before programming, the FLASH_CTRL.START bit must be cleared.</i> |
| 1         | Reserved | Reserved, the reset value must be maintained.   |
| 0         | BUSY     | Busy  |

| Bit field | Name | Description   |
|-----------|------|---|
|           |      | This bit indicates that a flash operation is in progress. At the beginning of flash operation, this bit is set to '1'; This bit is cleared to '0' when the operation ends or an error occurs. |

### 3.2.5.2.5 The FLASH control register (FLASH\_CTRL)

Address offset: 0x10

Reset value: 0x0000 0080

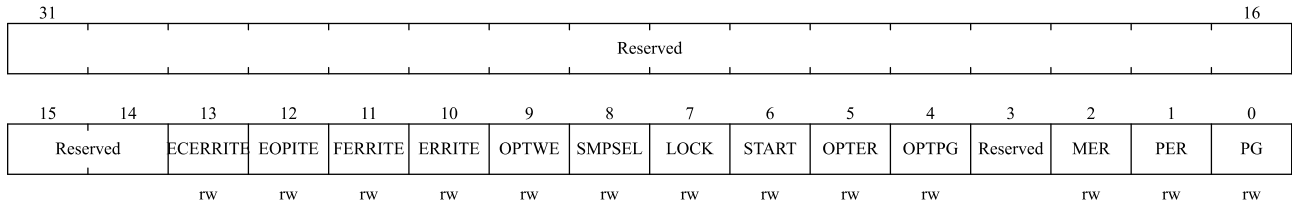

| Bit field | Name     | Description   |
|-----------|----------|---|
| 31:14     | Reserved | Reserved, the reset value must be maintained.   |
| 13        | ECERRITE | ECC error interrupt<br>This bit allows an interrupt to be generated when the FLASH_STS.ECCERR bit goes to '1'.<br>0: Interrupt generation is prohibited;<br>1: Enable interrupt generation.   |
| 12        | EOPITE   | Allow operation completion interrupt.<br>This bit allows an interrupt to be generated when the FLASH_STS.EOP bit becomes '1'.<br>0: interrupt generation is prohibited;<br>1: interrupt generation is allowed.                                    |
| 11        | FERRITE  | Erase/Program Verify Error Interrupt<br>This bit allows an interrupt to be generated when the FLASH_STS.EVERR/PVERR bit goes to '1'.<br>0: Interrupt generation is prohibited;<br>1: Enable interrupt generation.                                 |
| 10        | ERRITE   | Error status interrupt allowed<br>This bit allows an interrupt to be generated when a Flash error occurs (when FLASH_STS.PGERR/ FLASH_STS.WRPERR is set to '1').<br>0: interrupt generation is prohibited;<br>1: interrupt generation is allowed. |
| 9         | OPTWE    | Allow write option byte<br>When this bit is '1', the option byte is allowed to be programmed. When the correct key sequence is written in the FLASH_OPTKEY register, this bit is set to '1'.<br>Software can clear this bit.                      |
| 8         | SMPSEL   | Flash programming mode options<br>0: SMP1 mode. Before programming, you need to read the content of the address   |

| Bit field | Name     | Description  |
|-----------|----------|--|
|           |          | <p>where the programming is located, and check whether it has been erased. If it has not been erased, the programming operation will not be performed, and the FLASH_STS.PGERR warning bit will be set;</p> <p>1: SMP2 mode. Before programming, it will not judge whether the content of the address where the programming is located has been erased, and the Flash will directly start programming. If the programming address has been written with data before, only the same data can be written when programming the address in SMP2 mode, otherwise the data cannot be guaranteed to be written correctly.</p> |
| 7         | LOCK     | <p>Lock</p> <p>You can only write '1'. When this bit is '1', Flash and FLASH_CTRL are locked. After detecting the correct unlocking sequence, hardware clears this bit to '0'. After an unsuccessful unlocking operation, this bit cannot be changed until the next system reset.</p>  |
| 6         | START    | <p>Start</p> <p>When this bit is '1', an erase operation will be triggered. This bit can only be set to '1' by software and cleared to '0' when FLASH_STS.BUSY becomes '1'.</p>  |
| 5         | OPTER    | <p>Erase option bytes.</p> <p>0: Disable option bytes erase mode;</p> <p>1: Enable option bytes erase mode.</p>  |
| 4         | OPTPG    | <p>Program option bytes.</p> <p>0: Disable option bytes program mode;</p> <p>1: Enable option bytes program mode.</p>  |
| 3         | Reserved | Reserved, the reset value must be maintained.  |
| 2         | MER      | <p>Mass erase.</p> <p>0: disable mass erase mode;</p> <p>1: enable mass erase mode.</p>  |
| 1         | PER      | <p>Page erase.</p> <p>0: disable page erase mode;</p> <p>1: enable page erase mode</p>   |
| 0         | PG       | <p>Program.</p> <p>0: disable program mode;</p> <p>1: enable program mode.</p>   |

*Note: Please refer to section 3.2.1.4 for programming and erasing.*

### 3.2.5.2.6 The FLASH address register (FLASH\_ADD)

Address offset: 0x14

Reset value: 0x0000 0000

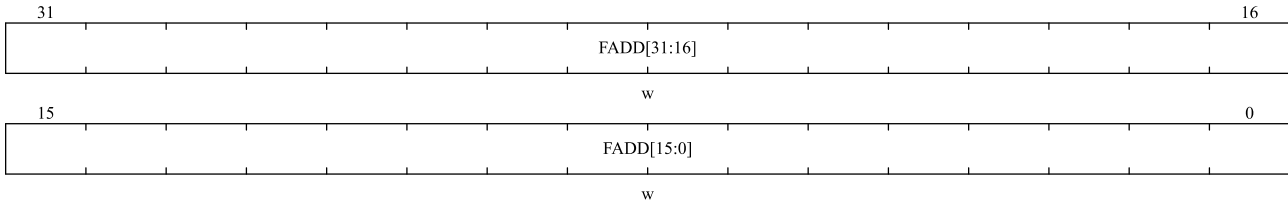

| Bit field | Name | Description   |
|-----------|------|---|
| 31:0      | FADD | Flash address<br>Select the address to be programmed when programming, and select the page to be erased when page erasing.<br><i>Note: When the FLASH_STS.BUSY bit is '1', this register cannot be written.</i> |

### 3.2.5.2.7 Option byte register (FLASH\_OB)

Address offset: 0x1C

Reset value: 0x03FF FFFC

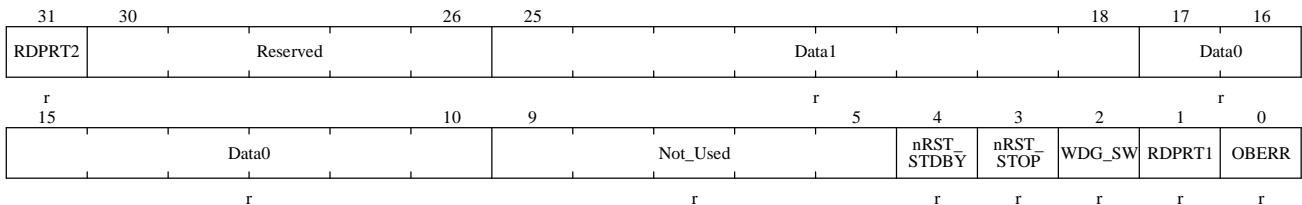

| Bit field | Name       | Description   |
|-----------|------------|---|
| 31        | RDPRT2     | Read protection L2 level protection<br>0: Read protection L2 level is not enabled;<br>1: Read protection L2 level is enabled.<br><i>Note: This bit is read-only.</i>  |
| 30:26     | Reserved   | Reserved, the reset value must be maintained.   |
| 25:18     | Data1[7:0] | Data1<br><i>Note: This bit is read-only.</i>  |
| 17:10     | Data0[7:0] | Data0<br><i>Note: This bit is read-only.</i>  |
| 9:5       | Reserved   | Not used, the hardware remains at 1.  |
| 4         | nRST_STDBY | Enter Standby mode reset configuration.<br>0: Reset immediately after entering Standby mode;<br>1: No reset occurs after entering Standby mode.<br><i>Note: This bit is read-only.</i>                        |
| 3         | nRST_STOP  | Enter STOP0/STOP2 mode reset configuration.<br>0: Reset occurs immediately after entering STOP0/STOP2 mode;<br>1: No reset occurs after entering the STOP0/STOP2 mode.<br><i>Note: This bit is read-only.</i> |
| 2         | WDG_SW     | Set watchdog<br>0: hardware watchdog;<br>1: Software watchdog.  |

| Bit field | Name   | Description  |
|-----------|--------|--|
|           |        | <i>Note: This bit is read-only.</i>  |
| 1         | RDPRT1 | Read protection L1 level protection<br>0: Read protection L1 level is not enabled;<br>1: read protection L1 level is enabled.<br><i>Note: This bit is read-only.</i> |
| 0         | OBERR  | Option byte error<br>When this bit is '1', it means that the option byte does not match its complement.<br><i>Note: This bit is read-only.</i>                       |

### 3.2.5.2.8 Write protection register (FLASH\_WRP)

Address offset: 0x20

Reset value: 0xFFFF FFFF

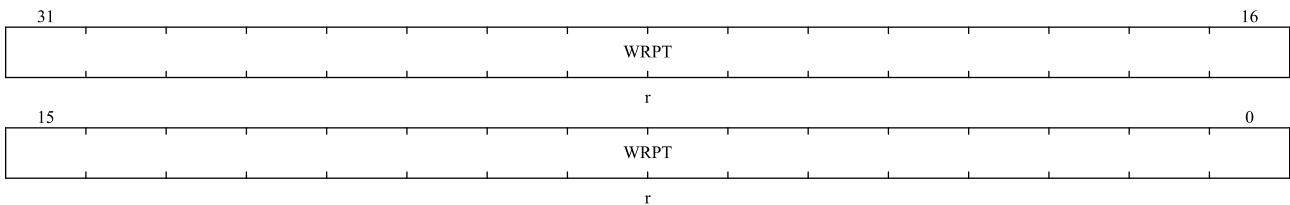

| Bit field | Name | Description  |
|-----------|------|--|
| 31:0      | WRPT | Write protect<br>This register contains the write protection option byte loaded by option byte area.<br>0: write protection takes effect;<br>1: Write protection is invalid.<br><i>Note: These bits are read-only.</i> |

### 3.2.5.2.9 ECC register (FLASH\_ECC)

Address offset: 0x24

Reset value: 0x0000 0000

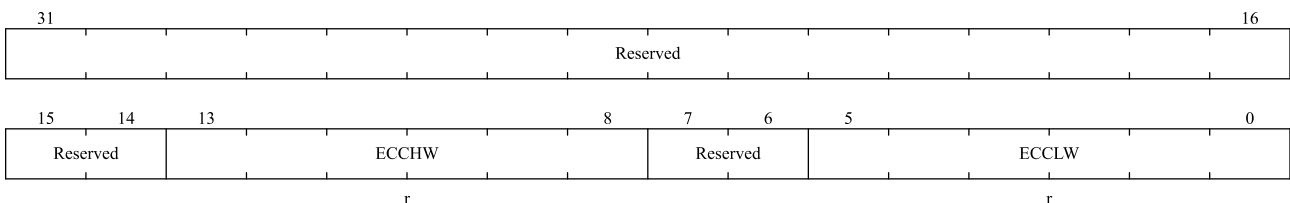

| Bit field | Name     | Description   |
|-----------|----------|---|
| 31:14     | Reserved | Reserved, the reset value must be maintained.   |
| 13:8      | ECCHW    | After writing a word to a 32-bit Flash address, the corresponding higher 6-bit ECC value. |
| 7:6       | Reserved | Reserved, the reset value must be maintained.   |
| 5:0       | ECCLW    | After writing a word to a 32-bit Flash address, the corresponding lower 6-bit ECC value.  |

### 3.2.5.2.10 RDN register (FLASH\_RDN)

Address offset: 0x2C

Reset value: 0x0000 0000

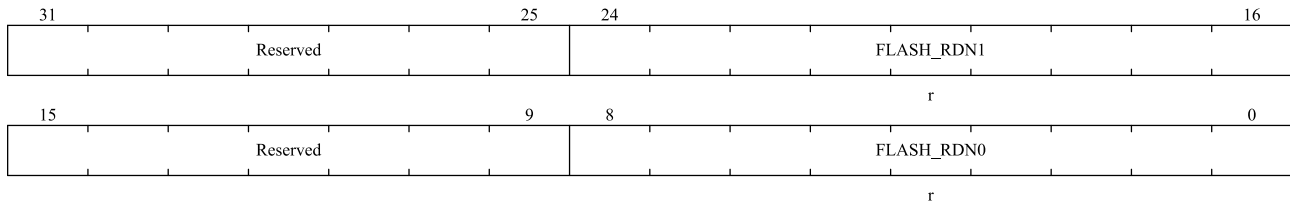

| Bit field | Name       | Description                                   |
|-----------|------------|---|
| 31:25     | Reserved   | Reserved, the reset value must be maintained. |
| 24:16     | FLASH_RDN1 | The address of Flash redundant block page 1   |
| 15:9      | Reserved   | Reserved, the reset value must be maintained. |
| 8:0       | FLASH_RDN0 | The address of Flash redundant block page 0   |

### 3.2.5.2.11 CAHR register (FLASH\_CAHR)

Address offset: 0x30

Reset value: 0x0000 0000

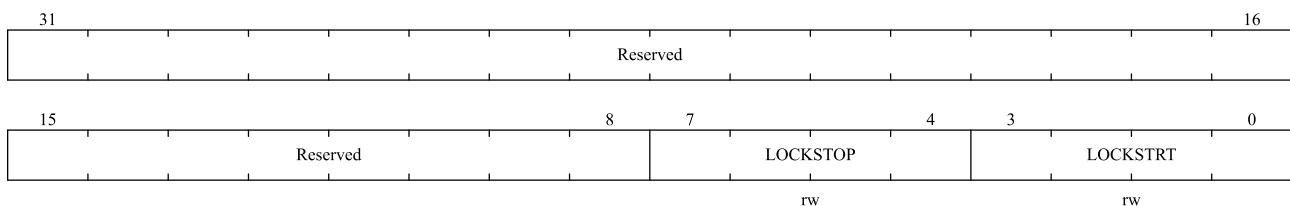

| Bit field | Name          | Description   |
|-----------|---------------|---|
| 31:8      | Reserved      | Reserved, the reset value must be maintained.   |
| 7:4       | LOCKSTOP[3:0] | iCache lock stop (see for detailed operation instructions 3.2.2.3.3 iCache locking Chapter).<br>0: disable<br>1: enable |
| 3:0       | LOCKSTRT[3:0] | iCache lock start.<br>0: disable<br>1: enable   |

## 4 Power control (PWR)

### 4.1 General description

PWR is power management unit to control status of different modules in different power modes. Its major function is to control MCU to enter different power modes and wakeup when events or interrupts happen. MCU supports RUN、SLEEP、STOP0、STOP2、STANDBY and VBAT mode.

#### 4.1.1 Power supply

◇ MCU working voltage (VDD) is 1.8V~3.6V. It mainly has 3 analog/digital power supply regions (VDD, VBAT, VDDA). For details, please refer to Figure 4-1 power supply block diagram. In order to illustrate the functions of different power domains, some power domains will be introduced below, and the digital parts of power domains will be introduced in later chapters of this document.

- V<sub>DD</sub> domain: The voltage input range is 1.8V~3.6V, mainly for MR,CPU,AHB,APB,SRAM,FLASH and most digital peripheral interfaces power supply.
- VBAT domain: The input voltage range is 1.8V~3.6V, which supplies power for BKR and some special IO (PC13, PC14, PC15) ports. When VDD is powered down, the switch switches the power supply system VDD to VBAT.
- VDDA domain: voltage input range is 1.8V~3.6V, mainly used for clock and reset system, most analog peripherals powered.

◇ BKR and MR are internal voltage regulators that can provide power for the digital module power supply system. VDD and VBAT are generally powered directly from the outside, VBAT is powered by the battery to keep the contents of the backup area, and VDD is powered by other external power supply systems. In addition, if no battery is required, then VBAT must be connected directly to VDD.

- **MR**

MR is the internal main power controller, mainly used in RUN mode, SLEEP mode and STOP0 mode. MR has two modes, normal mode and low power mode, the low power mode is used for STOP0 to further reduce power consumption.

When the MR enters a low power mode, the CPU goes into a deep sleep state. In this case, the PWR\_CTRL.PDS bit should be set to 0 and the PWR\_CTRL.LPS bit should be set to 1. When the MR enters the normal mode, the PWR\_CTRL.PDS bit needs to be set to 0, and the PWR\_CTRL.LPS bit is also 0.

- **BKR**

BKR is an internal backup domain power controller, used in STOP2, STANDBY and VBAT modes. In STOP2 mode, the CPU state is maintained and additionally supplies power to the digital backup area, GPIO and EXTI. When the CPU enters deep sleep, the PWR\_CTRL2.STOP2S bit should be set to 1 at this time.

The main modules of the digital backup area include PWR, IO (PA0\_WAKUP, PC13\_TAMPER, PC14, PC15), R-SRAM, RTC, BKR and RCC\_BDCTRL registers. When the SW3 switch is on, the CPU goes into a deep sleep state. When SW1 switches the power supply system to VBAT, it indicates that VDD has

been powered down at this time.

- ✧ When reset, SW1 will switch the power supply system to the VDD power supply area. In STOP2, STANDBY and VBAT modes, the internal voltage regulator BKR will power the digital backup area.
  - During the VDD rising phase or when PDR is detected, the switch between VBAT and VDD remains connected to the VBAT area.
  - During startup, if VDD is settling quickly and  $VDD > VBAT + 0.6V$ , current can be injected to VBAT through the internal diode connection. If the power supply connected to VBAT or the battery does not support this injection of current. It is strongly recommended to add a low voltage diode between this supply and the VBAT pin.

If there is no external battery in the application. It is recommended to connect the VBAT pin to VDD with a 100nF ceramic capacitor. In RUN, SLEEP, STOP0 mode, the backup area is powered by VDD (SW1 is connected to VDD), the following functions are available:

- PC14 and PC15 can be used for common IO ports or LSE pins
- PC13 can be used for common IO port, TAMPER pin, RTC check clock pin, RTC alarm and periodic wake-up output

*Notice:*

*Due to the fact that the current flowing through SW1 and SW2 is limited to a maximum of 3mA. Therefore, the IO output modes of PA0\_WAKUP, PC13 to PC15 are limited. When a 30PF capacitor is attached, the maximum output speed is 2MHz. In addition, these IOs cannot be driven by current, for example, they cannot drive LEDs. The current of SW2 will be maintained at 3mA or lower, because GPIO, and EXTI work together to consume current.*

When VBAT supplies power to the backup area, the following functions can be used at this time:

- PC14 and PC15 can only be used for LSE pins.
- PC13 is used for TAMPER pin, RTC alarm or periodic wake-up output

Figure 4-1 Power supply block diagram

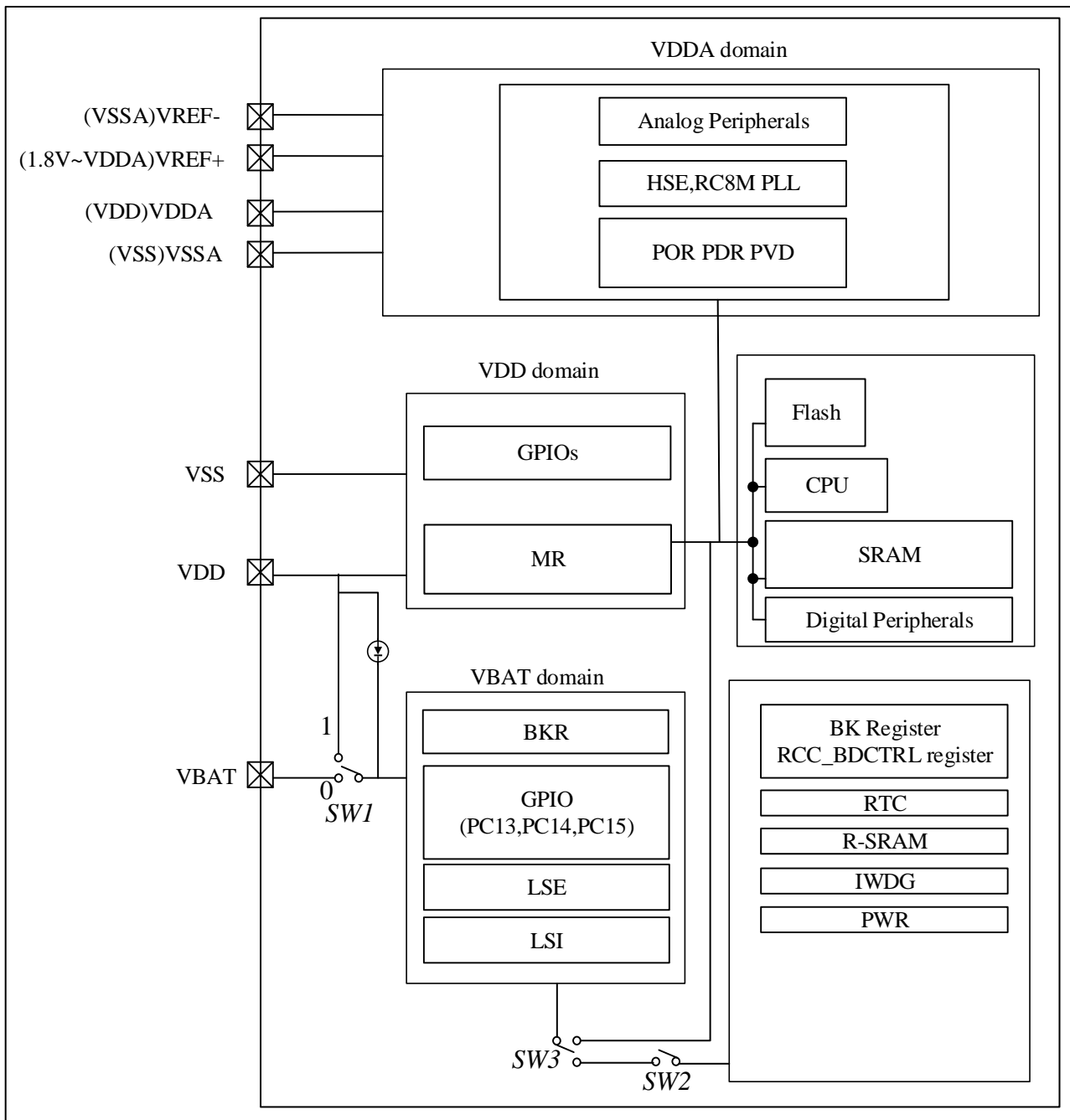

## 4.1.2 Power supply supervisor

### 4.1.2.1 Power on reset (POR) and power down reset (PDR)

Power-on reset (POR) and power down reset (PDR) circuits are integrated inside the chip. Can work with a minimum voltage of 1.8V. No external reset circuit is required. When VDD or VDDA is lower than the specified threshold ( $V_{POR/PDR}$ ), the chip will remain in reset state.

For more information on switching power supply reset thresholds, see the Electrical Characteristics section of the relevant data sheet.

Figure 4-2 Waveforms of power-on reset and power-down reset

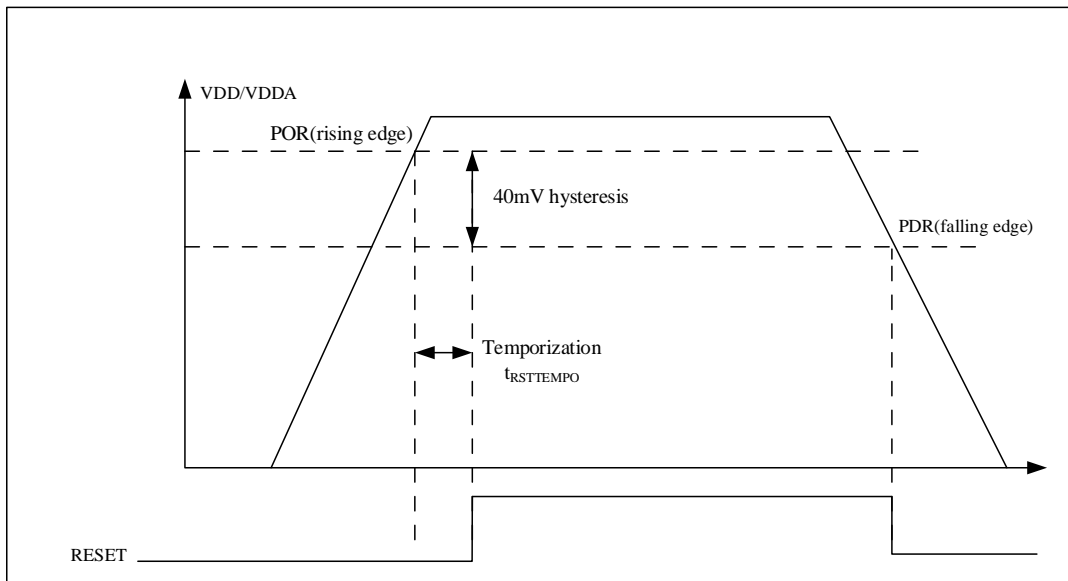

#### 4.1.2.2 Programmable voltage detector (PVD)

The PVD can be used to monitor the VDD/VDDA power supply by comparing with the thresholds set by the `PWR_CTRL.PRS[2:0]` bits of the power supply control register.

The `PWR_CTRLSTS.PVDO` flag is used to indicate if VDD/VDDA is above/below the PVD voltage threshold. This event is internally connected to the interrupt line 16 of the external interrupt, which will generate an interrupt if enabled in the external interrupt register. Depending on the rising/falling edge trigger settings of the external interrupt line 16, a PVD interrupt will occur when VDD/VDDA falls below the PVD threshold or VDD/VDDA rises above the PVD threshold. For example, this feature can be used to perform emergency shutdown tasks.

*Notice: MCU PVD threshold needs to be configured with the `PWR_CTRL3.EXMODE` bit. For details, please refer to the registers `PWR_CTRL.MSB` and `PWR_CTRL.PRS[2:0]`, their combination can form a 4-bit PVD threshold configuration.*

Figure 4-3 PVD threshold waveform

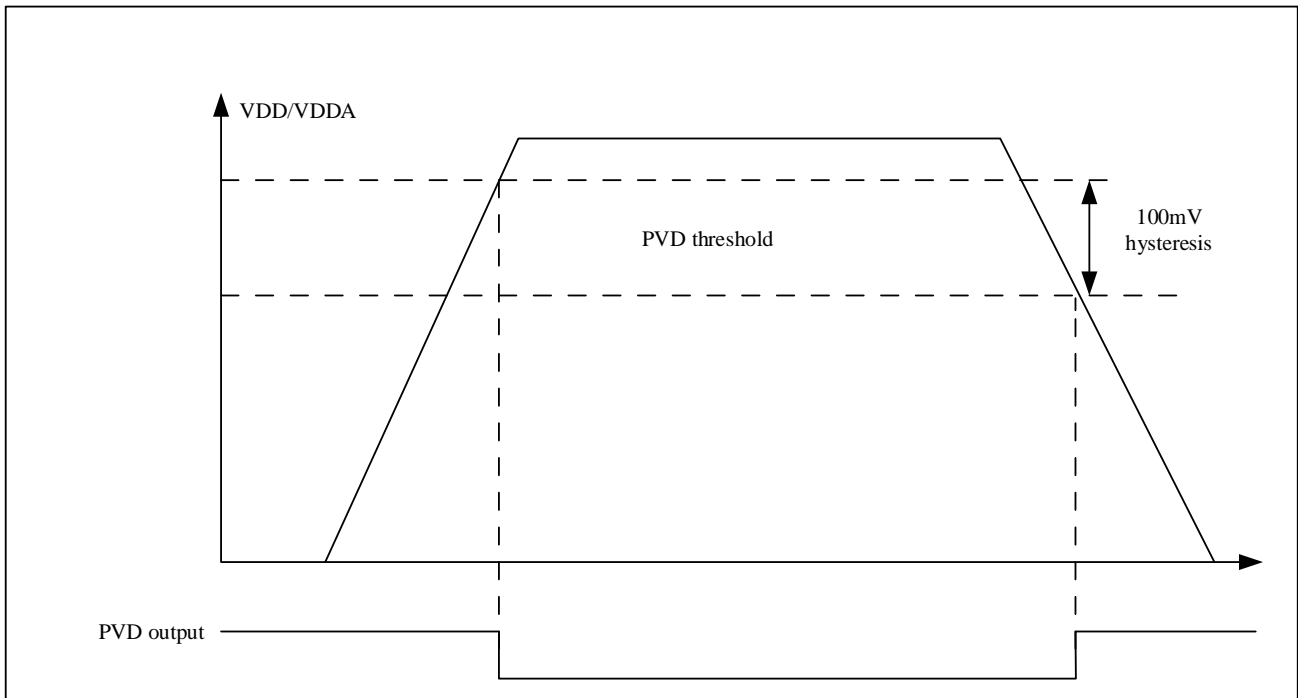

#### 4.1.2.3 Brown\_out reset (BOR)

BOR is a power-down reset controller built into the device, when the VDD voltage is lower than 1.62V (typ), the device will remain in reset state.

## 4.2 Power modes

Overall MCU has 6 power modes: RUN, SLEEP, STOP0, STOP2, STANDBY and VBAT. Different mode has different performance and power consumption. A summary of MCU power modes is shown below.

Table 4-1 Power modes

| Mode                 | Condition   | Enter  | Exit  |
|----------------------|---|--|---|
| RUN                  | CPU boot<br>Peripheral configuration  | Power on, system reset, low power wake-up  | Enter sleep, STOP0, STOP2, standby and VBAT modes   |
| SLEEP                | CPU goes to sleep mode and the kernel stops. With all peripherals configured, the voltage regulator is still running. Any interrupt and event can wake up the CPU | 1) SCB_SCR.SLEEPDEEP = 0,<br>SCB_SCR.SLEEPONEXIT = 0,<br>WFI/WFE<br>2) SCB_SCR.SLEEPDEEP = 0, SCB_SCR.SLEEPONEXIT = 1,<br>No interrupt waiting, CPU returns from ISR | wake:<br>1) If entered via WFI or set SCB_SCR.SLEEPONEXIT = 1, any NVIC interrupt can exit<br>2) If entered via WFE or set SCB_SCR.SEVONPEND=1, any peripheral interrupt can exit; SCB_SCR.SEVONPEND=0, the external interrupt line exits |
| STOP0 <sup>[1]</sup> | CPU deep sleep mode:<br>Peripheral clocks, all digital blocks and   | WFI / WFE:<br>1) SCB_SCR.SLEEPDEEP =   | wake:<br>1) If entered by WFI, any from   |

| Mode                 | Condition  | Enter   | Exit   |
|----------------------|--|---|--|
|                      | <p>voltage regulators are still running.</p> <p>HSE/HSI/PLL is turned off.</p> <p>LSE/LSI, RTC or other peripherals can be configured to wake up.</p> <p>All SRAM data retention, all IO ports, IWDG and RTC can be used to wake up the CPU.</p> <p>After waking up, HSI is turned on, and the code starts from where it hangs.</p>  | <p>1, PWR_CTRL.PDS=0,</p> <p>2) PWR_CTRL.LPS=0/1,</p> <p>Select the main voltage regulator operating mode</p> | <p>external interrupt/event line (NVIC enabled), it can be external interrupt or internal peripheral</p> <p>2) If entered by WFE, SCB_SCR.SEVONPEND=0, any event line from external</p> <p>3) If entered by WFE, SCB_SCR.SEVONPEND=1, any interrupt from external or internal peripheral</p>   |
| STOP2 <sup>[2]</sup> | <p>CPU deep sleep mode:</p> <p>CPU registers are maintained, and all core digital logic areas are powered off.</p> <p>The main voltage regulator (MR) is turned off and the HSE/HSI/PLL is turned off.</p> <p>LSE/LSI configurable,</p> <p>GPIO is maintained, and peripheral IO multiplexing is not maintained. 16KB R-SRAM data retention, other SRAM and register data are lost.</p> <p>84B BK register retention.</p> <p>GPIOs and EXTI are enabled.</p>     | <p>WFI/WFE:</p> <p>1) SCB_SCR.SLEEPDEEP = 1</p> <p>2) PWR_CTRL2.STOP2S = 1</p>                                | <p>wake:</p> <p>1) If entered by WFI, any from external interrupt/event line (NVIC enabled), it can be external interrupt or internal peripheral</p> <p>2) If entered by WFE, SCB_SCR.SEVONPEND=0, any event line from external</p> <p>3) If entered by WFE, SCB_SCR.SEVONPEND=1, any interrupt from external or internal peripheral</p> |
| STANDBY              | <p>The main voltage regulator is turned off and the HSE/HSI/PLL is turned off.</p> <p>LSE/LSI is configurable.</p> <p>16KB bytes of R-SRAM retention, configured through PWR_CTRL2.SR2STBRET. Other SRAM and register data are lost.</p> <p>Except for the following NRST/PA0_WKUP/PC13-TAMPER/PC14-OSC32_IN/PC15-OSC32_OUT, other IOs are high impedance.</p> <p>The 84-byte BK register data retention, IWDG, RTC/PA0WKUP/NRST/TAMPER can wake up the CPU.</p> | <p>WFI/WFE:</p> <p>1) SCB_SCR.SLEEPDEEP = 1</p> <p>interrupt/event</p> <p>2) PWR_CTRL.PDS=1</p>               | <p>WKUP high level, RTC alarm high level, NRST reset, IWDG reset</p>   |
| VBAT                 | <p>CPU off, all peripherals off, main voltage regulator off, LSE/LSI configurable,</p> <p>HSE/HSI/PLL off. Except for NRST/PC13-TAMPER/PC14-OSC32_IN/PC15-OSC32_OUT, most IO ports are in high impedance state.</p>  | VDD disable   | VDD enable   |

Note:

1. *STOP0 mode, after wake-up, the code can continue running from the stop position.*
2. *In STOP2 mode, after waking up, the heap and global variables in the R-SRAM area can resume and continue from the stopped position, and the peripherals need to be re-initialized at this time.*

The running enable conditions of different modules in different power consumption modes are shown in the following table:

 Table 4-2 Blocks running state<sup>(1)</sup>

| Peripheral       | Run | Sleep       | Stop 0      |                   | Stop 2 |                   | Standby |                   | VBAT |
|------------------|-----|-------------|-------------|-------------------|--------|-------------------|---------|-------------------|------|
|                  |     |             | -           | Wakeup capability | -      | Wakeup capability | -       | Wakeup capability |      |
| MR               | Y   | Y           | (3)         | -                 | OFF    | -                 | OFF     | -                 | OFF  |
| BKR              | Y   | Y           | Y           | -                 | Y      | -                 | Y       | -                 | Y    |
| POR              | Y   | Y           | Y           | -                 | Y      | -                 | Y       | Y                 |      |
| PDR              | Y   | Y           | Y           | -                 | Y      | -                 | Y       | Y                 | -    |
| PVD              | O   | O           | O           | O                 | O      | O                 | -       | -                 | -    |
| BKPOR/PDR        | Y   | Y           | Y           | -                 | Y      | -                 | Y       | -                 | Y    |
| CPU              | Y   | HCLK<br>(O) | HCLK<br>(O) | -                 | -      | -                 | OFF     | -                 | OFF  |
| Flash            | O   | O           | (4)         | -                 | OFF    | -                 | OFF     | -                 | OFF  |
| SRAM             | Y   | Y           | Y           | -                 | OFF    | -                 | OFF     | -                 | OFF  |
| R-SRAM           | Y   | O           | Y           | -                 | O      | -                 | O       | -                 | O    |
| Backup Registers | Y   | Y           | Y           | -                 | Y      | -                 | Y       | -                 | Y    |
| DMA              | O   | O           | -           | -                 | -      | -                 | -       | -                 | -    |
| HSI              | O   | O           | OFF         | -                 | OFF    | -                 | OFF     | -                 | OFF  |
| HSE              | O   | O           | OFF         | -                 | OFF    | -                 | OFF     | -                 | OFF  |
| LSI              | O   | O           | O           | -                 | O      | -                 | O       | -                 | O    |
| LSE              | O   | O           | O           | -                 | O      | -                 | O       | -                 | O    |

| Peripheral                | Run | Sleep | Stop 0 |                   | Stop 2 |                   | Standby |                   | VBAT |
|---------------------------|-----|-------|--------|-------------------|--------|-------------------|---------|-------------------|------|
|                           |     |       | -      | Wakeup capability | -      | Wakeup capability | -       | Wakeup capability |      |
| CSS                       | 0   | 0     | -      | -                 | -      | -                 | -       | -                 | -    |
| RTC / Auto wakeup         | 0   | 0     | 0      | 0                 | 0      | 0                 | 0       | 0                 | 0    |
| Number of RTC Tamper pins | 1   | 1     | 1      | 0                 | 1      | 0                 | 1       | 0                 | 1    |
| USART1/2/3                | 0   | 0     | -      | -                 | -      | -                 | -       | -                 | -    |
| UART4/5/6/7               | 0   | 0     | -      | -                 | -      | -                 | -       | -                 | -    |
| I2C1/2/3/4                | 0   | 0     | -      | -                 | -      | -                 | -       | -                 | -    |
| SPI1/2/3                  | 0   | 0     | -      | -                 | -      | -                 | -       | -                 | -    |
| CAN1/2                    | 0   | 0     | -      | -                 | -      | -                 | -       | -                 | -    |
| USB                       | 0   | 0     | -      | -                 | -      | -                 | -       | -                 | -    |
| ETH MAC                   | 0   | 0     | -      | -                 | -      | -                 | -       | -                 | -    |
| QSPI                      | 0   | 0     | -      | -                 | -      | -                 | -       | -                 | -    |
| SDMMC                     | 0   | 0     | -      | -                 | -      | -                 | -       | -                 | -    |
| ADC                       | 0   | 0     | -      | -                 | -      | -                 | -       | -                 | -    |
| DAC                       | 0   | 0     | -      | -                 | -      | -                 | -       | -                 | -    |
| OPAMP                     | 0   | 0     | -      | -                 | -      | -                 | -       | -                 | -    |
| COMP                      | 0   | 0     | 0      | 0                 | -      | -                 | -       | -                 | -    |
| DVP                       | 0   | 0     | -      | -                 | -      | -                 | -       | -                 | -    |
| Tempsensor                | 0   | 0     | -      | -                 | -      | -                 | -       | -                 | -    |
| TIMx                      | 0   | 0     | -      | -                 | -      | -                 | -       | -                 | -    |
| IWDG                      | 0   | 0     | 0      | 0                 | 0      | 0                 | 0       | 0                 | -    |

| Peripheral | Run | Sleep | Stop 0 |                   | Stop 2 |                   | Standby |                   | VBAT |
|------------|-----|-------|--------|-------------------|--------|-------------------|---------|-------------------|------|
|            |     |       | -      | Wakeup capability | -      | Wakeup capability | -       | Wakeup capability |      |
| WWDG       | O   | O     | -      | -                 | -      | -                 | -       | -                 | -    |
| SysTick    | O   | O     | -      | -                 | -      | -                 | -       | -                 | -    |
| SAC        | O   | O     | -      | -                 | -      | -                 | -       | -                 | -    |
| RNG        | O   | O     | -      | -                 | -      | -                 | -       | -                 | -    |
| CRC        | O   | O     | -      | -                 | -      | -                 | -       | -                 | -    |
| GPIOs      | O   | O     | O      | O                 | O      | O                 | Y       | 2pins             | -    |

Note:

1. *Y means Yes (enable), O means Option (optional), - means invalid, OFF means close,*
2. *2pins represent 2 wakeup IOs, PA0\_WKUP and NRST*
3. *MR can select to work in normal mode or in low power mode*
4. *FLASH is in sleep (Flash itself) mode.*

## 4.2.1 SLEEP mode

The CPU stops and all peripherals including peripherals around the Cortex®-M4F core (such as NVIC, SysTick, etc.) can run and wake up the CPU when an interrupt or event occurs. In SLEEP mode, all I/O pins maintain the same state/function as in RUN mode.

### 4.2.1.1 Enter SLEEP mode

Enter SLEEP mode by executing WFI (wait for interrupt) or WFE (wait for event) instruction with SCB\_SCR.SLEEPDEEP = 0. Depending on the SCB\_SCR.SLEEPONEXIT, there are two options for SLEEP mode entry:

- SLEEP-NOW: If SCB\_SCR.SLEEPONEXIT = 0, then WFI or WFE instruction is executed immediately, and the system enters sleep mode immediately.
- SLEEP-ON-EXIT: If SCB\_SCR.SLEEPONEXIT = 1, the system immediately enters sleep mode when exiting from the lowest priority ISR.

In SLEEP mode, all I/O pins maintain the same state/function as in RUN mode.

### 4.2.1.2 Exit SLEEP mode

If WFI instruction is used to enter the SLEEP mode, any NVIC interrupts can wake up the device from the SLEEP mode.

If the WFE instruction is used to enter the SLEEP mode, MCU will exit the SLEEP mode immediately when the

event occurs. Wake-up events can be generated in the following ways:

- Enable an interrupt in the peripheral control register instead of NVIC, and enable the SCB\_SCR.SEVONPEND. When MCU wakes up by WFE, the peripheral interrupt suspend bit and the peripheral NVIC interrupt channel suspend bit (in NVIC interrupt clear suspend register) must be cleared.
- Configure an external or internal EXTI event mode. When the MCU wakes up, it is not necessary to clear the peripheral interrupt suspend bit and the peripheral NVIC interrupt channel suspend bit (in the NVIC interrupt clear suspend register) because the suspend bit corresponding to the event line is not set. This mode provides the shortest wake-up time because there is no time spent on interrupt entry or exit.

## 4.2.2 STOP0 mode

STOP0 mode is based on Cortex®-M4 deep sleep mode combined with peripheral clock control mechanism. The voltage regulator can be configured in normal or low power mode. In STOP0 mode, most of the clock sources in the core domain are disabled, such as PLL, HSI and HSE. But SRAM, R-SRAM and all register contents are preserved.

In STOP0 mode, all I/O pins maintain the same state as in RUN mode.

### 4.2.2.1 Enter STOP0 mode

When entering STOP0 mode, the main difference is to set SCB\_SCR.SLEEPDEEP=1, PWR\_CTRL.PDS=0. Another difference is that MR can run in normal mode or low power mode by configuring register PWR\_CTRL.LPS. When PWR\_CTRL.LPS = 1, MR runs in low power mode.

When PWR\_CTRL.LPS = 0, MR operates in normal mode.

In STOP0 mode, all I/O pins maintain the same state and function as in RUN mode.

If a FLASH operation is in progress, the time to enter STOP0 mode will be delayed until the memory access is completed.

If an access to the APB area is in progress, the time to enter STOP0 mode will be delayed until the APB access is complete.

In STOP0 mode, the following characteristics can be selected by programming the individual control bits:

- Independent watchdog (IWDG): The independent watchdog will be activated when its related registers are written by software or operated by hardware. Once activated, it will keep working until a reset message is generated.
- RTC: can be turned on by register RCC\_BDCTRL.RTCEN bit
- Internal RC oscillator (LSI RC): can be turned on by register RCC\_CTRLSTS.LSIEN bit
- External 32.768kHz crystal oscillator (LSE OSC): can be turned on by register RCC\_BDCTRL.LSEEN.

ADC or DAC can also consume power in STOP0 mode, ADC and DAC can be disabled before entering STOP0 mode.

*Note: If the application needs to disable the external clock before entering stop mode, it must first disable the RCC\_CTRL.HSEEN bit and then switch the system clock to HSI. Otherwise, if the RCC\_CTRL.HSEEN bit remains enabled when entering stop mode and the external clock (external oscillator) is removed, the Clock Safety System (CSS) feature must be enabled to detect any external oscillator failure and avoid entering stop Failed behavior when*

mode.

#### 4.2.2.2 Exit STOP0 mode

When an interrupt or wake-up event is generated to exit STOP0 mode, the HSI RC oscillator is selected as the system clock.

When the voltage regulator is operating in low power mode, there is an additional startup delay when waking up from STOP0 mode. In STOP0 mode, the internal regulator is in normal mode, which can reduce the startup time, but the corresponding power consumption will increase.

### 4.2.3 STOP2 mode

STOP2 mode is based on Cortex®-M4F deep sleep mode, all core digital logic areas are powered off. The main voltage regulator (MR) is turned off and the HSE/HSI/PLL is turned off. CPU register retention, LSE/LSI configurable, GPIO retention, peripheral IO multiplexing is not retained. 16K bytes R-SRAM retention, other SRAM and register data are lost. 84 bytes of backup register retention. GPIOs and EXTI enabled.

#### 4.2.3.1 Enter STOP2 mode

To enter STOP2 mode, should be configured: SCB\_SCR.SLEEPDEEP = 1, PWR\_CTRL2.STOP2S = 1, PWR\_CTRL.PDS = 0, PWR\_CTRL.LPS = 0.

In STOP2 mode, if FLASH is being operated, the time to enter STOP2 mode will be delayed until the memory access is completed.

If the access to the APB area is in progress, the time to enter the STOP2 mode will be delayed until the APB access is completed.

In STOP2 mode, the following peripherals are available:

- Independent Watchdog (IWDG) optional: Once enabled, it will keep counting until a reset is generated.
- RTC optional: It can be turned on by RCC\_BDCTRL.RTCEN.
- Internal RC oscillator (LSI RC) optional: It can be turned on by RCC\_CTRLSTS.LSIEN.
- External 32.768kHz crystal oscillator (LSE OSC) optional: It can be turned on by RCC\_BDCTRL.LSEEN bit.

*Note: If you want to keep data (global variables, stack, etc.) when entering STOP2, you should put it in R-SRAM.*

#### 4.2.3.2 Exit STOP2 mode

When the STOP2 mode is exited by generating an interrupt or a wake-up event, the HSI RC oscillator is selected as the system clock, and the code execution will continue from where it stopped.

*Note: Avoid exiting STOP2 mode within 100us after entering STOP2 mode.*

### 4.2.4 STANDBY mode

STANDBY mode is a Cortex®-M4 based Deep-Sleep mode. The core domain is completely closed, and the backup region is open to supply power to BKR.

#### 4.2.4.1 Enter STANDBY mode

When entering STANDBY mode. The main difference is to set SCB\_SCR.SLEEPDEEP=1, PWR\_CTRL.PDS=1.

In STANDBY mode, all I/O pins remain high impedance except NRST, PA0\_WKUP, PC13\_TAMPER, PC14, PC15.

If an operation is in progress on FLASH, the time to enter STANDBY mode will be delayed until the memory access is complete.

If an access to the APB area is in progress, the time to enter STANDBY mode will be delayed until the APB access is complete.

In STANDBY mode, the following features can be selected by programming individual control bits:

- Independent Watchdog (IWDG) optional: Once enabled, it will keep counting until a reset is generated.
- RTC optional: It can be turned on by RCC\_BDCTRL.RTCEN.
- Internal RC oscillator (LSI RC) optional: It can be turned on by RCC\_CTRLSTS.LSIEN.
- External 32.768kHz crystal oscillator (LSE OSC) optional: It can be turned on by RCC\_BDCTRL.LSEEN bit.
- R-SRAM data retention, which can be turned on by register PWR\_CTRL2.SR2STBRET.

#### 4.2.4.2 Exit STANDBY mode

MCU exits STANDBY mode when an external reset (NRST pin), IWDG reset, high level of the WKUP pin, or a high level of the RTC alarm event occurs. Except for the power status register (PWR\_CTRLSTS), all registers are reset after waking up from STANDBY state.

After waking up from STANDBY mode, code execution is the same as reset (detecting BOOT pin, getting reset vector, etc.). The PWR\_CTRLSTS.SBF status flag indicates that the MCU exits STANDBY mode.

### 4.2.5 VBAT mode

In VBAT mode the CPU is turned off, all peripherals are turned off, the main voltage regulator is turned off, the LSE/LSI is configurable, and the HSE/HSI/PLL is turned off. Except for NRST/PC13-TAMPER/PC14-OSC32\_IN/PC15-OSC32\_OUT, most IO ports are in high impedance state.

In VBAT mode, depending on the configuration before VDD is powered down, the following features are available:

- RTC optional: It can be turned on by RCC\_BDCTRL.RTCEN.
- Internal RC oscillator (LSI RC) optional: It can be turned on by RCC\_CTRLSTS.LSIEN.
- External 32.768kHz crystal oscillator (LSE OSC) optional: It can be turned on by RCC\_BDCTRL.LSEEN bit.
- R-SRAM data retention, which can be turned on by register PWR\_CTRL2.SR2STBRET.

#### 4.2.5.1 Enter VBAT mode

When VDD is powered down, it will enter VBAT mode at any time.

#### 4.2.5.2 Exit VBAT mode

When VDD returns to the power-on reset threshold, the MCU exits VBAT mode. After VDD is restored, the core area of the MCU will be completely executed according to the power-on sequence. After waking up from VBAT mode, code execution is identical to execution after reset. The PWR\_CTRLSTS.VBATF status flag indicates that the MCU exits from VBAT mode.

### 4.3 Low-power auto-wakeup (AWU) mode

In automatic wake-up mode, the RTC can be used to wake up from different low-power modes without relying on external interrupts. The RTC provides a programmable clock reference for timed wake-up from STOP0, STOP2 and STANDBY modes. To do this, two of the three optional RTC clock sources can be selected by software programming RCC\_BDCTRL.RTCSEL[1:0] as follows:

- 32.768kHz external crystal clock (LSE OSC)

This clock source provides an accurate clock reference with very low power consumption.

- RC internal crystal clock (LSI RC)

This clock source has the advantage of saving the cost of the 32.768 kHz crystal, but the clock accuracy is worse than the LSE.

To wake up from STOP2 mode using the RTC alarm event, you need:

- Configure EXTI 17 rising edge trigger.
- Configure RTC to enable RTC alarm event.

To wake up from STANDBY mode using RTC alarm event, EXTI 17 does not need to be configured.

VBAT mode cannot wake up via RTC.

### 4.4 PWR registers

#### 4.4.1 PWR register overview

Table 4-3 PWR register overview

| Offset | Register    | 31       | 30 | 29 | 28 | 27 | 26 | 25 | 24 | 23 | 22 | 21 | 20 | 19 | 18 | 17 | 16 | 15 | 14 | 13 | 12 | 11 | 10 | 9         | 8        | 7            | 6 | 5      | 4     | 3       | 2         | 1        | 0      |  |  |       |      |     |       |  |  |  |  |  |  |  |  |  |  |
|--------|-------------|----------|----|----|----|----|----|----|----|----|----|----|----|----|----|----|----|----|----|----|----|----|----|-----------|----------|--------------|---|--------|-------|---------|-----------|----------|--------|--|--|-------|------|-----|-------|--|--|--|--|--|--|--|--|--|--|
| 000h   | PWR_CTRL    | Reserved |    |    |    |    |    |    |    |    |    |    |    |    |    |    |    |    |    |    |    |    |    | MSB       | DBKP     | PRS[2:0]     |   |        | PVDEN | CSVBAT  | CWKUP     | PDS      | LPS    |  |  |       |      |     |       |  |  |  |  |  |  |  |  |  |  |
|        | Reset Value |          |    |    |    |    |    |    |    |    |    |    |    |    |    |    |    |    |    |    |    |    |    | 0         | 0        | 0            | 0 | 0      | 0     |         |           |          |        |  |  |       |      |     |       |  |  |  |  |  |  |  |  |  |  |
| 004h   | PWR_CTRLSTS | Reserved |    |    |    |    |    |    |    |    |    |    |    |    |    |    |    |    |    |    |    |    |    | WKUPEN    |          | Reserved     |   |        |       |         |           |          |        |  |  | VBATF | PVDO | SBF | WKUPF |  |  |  |  |  |  |  |  |  |  |
|        | Reset Value |          |    |    |    |    |    |    |    |    |    |    |    |    |    |    |    |    |    |    |    |    |    | 0         |          |              |   |        |       |         |           |          |        |  |  | 0     | 0    | 0   | 0     |  |  |  |  |  |  |  |  |  |  |
| 008h   | PWR_CTRL2   | Reserved |    |    |    |    |    |    |    |    |    |    |    |    |    |    |    |    |    |    |    |    |    | IWDGRSTEN | IWDGWPEN | LSITRIM[4:0] |   |        |       | TMPWPEN | SR2STBRET | SR2VBRET | STOP2S |  |  |       |      |     |       |  |  |  |  |  |  |  |  |  |  |
|        | Reset Value |          |    |    |    |    |    |    |    |    |    |    |    |    |    |    |    |    |    |    |    |    |    | 1         | 1        | 0            | 1 | 1      | 1     | 0       | 0         | 1        | 0      |  |  |       |      |     |       |  |  |  |  |  |  |  |  |  |  |
| 00Ch   | PWR_CTRL3   | Reserved |    |    |    |    |    |    |    |    |    |    |    |    |    |    |    |    |    |    |    |    |    |           |          |              |   | EXMODE |       |         |           |          |        |  |  |       |      |     |       |  |  |  |  |  |  |  |  |  |  |
|        | Reset Value |          |    |    |    |    |    |    |    |    |    |    |    |    |    |    |    |    |    |    |    |    |    |           |          |              |   | 0      |       |         |           |          |        |  |  |       |      |     |       |  |  |  |  |  |  |  |  |  |  |

#### 4.4.2 Power control register (PWR\_CTRL)

Address offset: 0x00

Reset value: 0x0000 0700 (reset by wakeup from STANDBY mode)

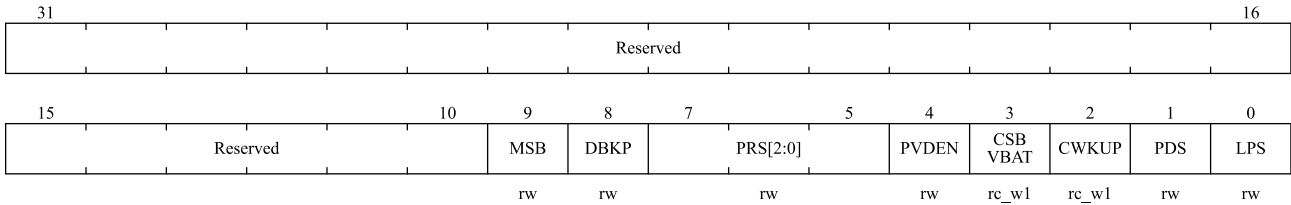

| Bit field       | Name     | Description   |                 |         |      |      |      |      |      |      |      |      |      |      |      |      |      |      |      |      |                 |         |      |       |      |       |      |       |      |       |      |       |      |       |      |       |      |       |
|-----------------|----------|---|-----------------|---------|------|------|------|------|------|------|------|------|------|------|------|------|------|------|------|------|-----------------|---------|------|-------|------|-------|------|-------|------|-------|------|-------|------|-------|------|-------|------|-------|
| 31:10           | Reserved | Reserved, the reset value must be maintained.   |                 |         |      |      |      |      |      |      |      |      |      |      |      |      |      |      |      |      |                 |         |      |       |      |       |      |       |      |       |      |       |      |       |      |       |      |       |
| 9               | MSB      | <p>4-bit PVD threshold setting bits.</p> <p>This bit is operational when PWR_CTRL3.EXMODE = 1.</p> <p>Therefore, the PWR_CTRL3.EXMODE bit needs to be configured first.</p> <p>When the MSB bit is 0, the threshold is as follows:</p> <table border="1" style="width: 100%; border-collapse: collapse; margin: 5px 0;"> <thead> <tr> <th style="text-align: left;">register(4bits)</th> <th style="text-align: left;">Voltage</th> </tr> </thead> <tbody> <tr><td>0000</td><td>2.2v</td></tr> <tr><td>0001</td><td>2.3v</td></tr> <tr><td>0010</td><td>2.4v</td></tr> <tr><td>0011</td><td>2.5v</td></tr> <tr><td>0100</td><td>2.6v</td></tr> <tr><td>0101</td><td>2.7v</td></tr> <tr><td>0110</td><td>2.8v</td></tr> <tr><td>0111</td><td>2.9v</td></tr> </tbody> </table> <p>When the MSB bit is 1, the threshold is as follows:</p> <table border="1" style="width: 100%; border-collapse: collapse; margin: 5px 0;"> <thead> <tr> <th style="text-align: left;">register(4bits)</th> <th style="text-align: left;">Voltage</th> </tr> </thead> <tbody> <tr><td>1000</td><td>1.78v</td></tr> <tr><td>1001</td><td>1.88v</td></tr> <tr><td>1010</td><td>1.98v</td></tr> <tr><td>1011</td><td>2.08v</td></tr> <tr><td>1100</td><td>3.06v</td></tr> <tr><td>1101</td><td>3.24v</td></tr> <tr><td>1110</td><td>3.42v</td></tr> <tr><td>1111</td><td>3.60v</td></tr> </tbody> </table> | register(4bits) | Voltage | 0000 | 2.2v | 0001 | 2.3v | 0010 | 2.4v | 0011 | 2.5v | 0100 | 2.6v | 0101 | 2.7v | 0110 | 2.8v | 0111 | 2.9v | register(4bits) | Voltage | 1000 | 1.78v | 1001 | 1.88v | 1010 | 1.98v | 1011 | 2.08v | 1100 | 3.06v | 1101 | 3.24v | 1110 | 3.42v | 1111 | 3.60v |
| register(4bits) | Voltage  |   |                 |         |      |      |      |      |      |      |      |      |      |      |      |      |      |      |      |      |                 |         |      |       |      |       |      |       |      |       |      |       |      |       |      |       |      |       |
| 0000            | 2.2v     |   |                 |         |      |      |      |      |      |      |      |      |      |      |      |      |      |      |      |      |                 |         |      |       |      |       |      |       |      |       |      |       |      |       |      |       |      |       |
| 0001            | 2.3v     |   |                 |         |      |      |      |      |      |      |      |      |      |      |      |      |      |      |      |      |                 |         |      |       |      |       |      |       |      |       |      |       |      |       |      |       |      |       |
| 0010            | 2.4v     |   |                 |         |      |      |      |      |      |      |      |      |      |      |      |      |      |      |      |      |                 |         |      |       |      |       |      |       |      |       |      |       |      |       |      |       |      |       |
| 0011            | 2.5v     |   |                 |         |      |      |      |      |      |      |      |      |      |      |      |      |      |      |      |      |                 |         |      |       |      |       |      |       |      |       |      |       |      |       |      |       |      |       |
| 0100            | 2.6v     |   |                 |         |      |      |      |      |      |      |      |      |      |      |      |      |      |      |      |      |                 |         |      |       |      |       |      |       |      |       |      |       |      |       |      |       |      |       |
| 0101            | 2.7v     |   |                 |         |      |      |      |      |      |      |      |      |      |      |      |      |      |      |      |      |                 |         |      |       |      |       |      |       |      |       |      |       |      |       |      |       |      |       |
| 0110            | 2.8v     |   |                 |         |      |      |      |      |      |      |      |      |      |      |      |      |      |      |      |      |                 |         |      |       |      |       |      |       |      |       |      |       |      |       |      |       |      |       |
| 0111            | 2.9v     |   |                 |         |      |      |      |      |      |      |      |      |      |      |      |      |      |      |      |      |                 |         |      |       |      |       |      |       |      |       |      |       |      |       |      |       |      |       |
| register(4bits) | Voltage  |   |                 |         |      |      |      |      |      |      |      |      |      |      |      |      |      |      |      |      |                 |         |      |       |      |       |      |       |      |       |      |       |      |       |      |       |      |       |
| 1000            | 1.78v    |   |                 |         |      |      |      |      |      |      |      |      |      |      |      |      |      |      |      |      |                 |         |      |       |      |       |      |       |      |       |      |       |      |       |      |       |      |       |
| 1001            | 1.88v    |   |                 |         |      |      |      |      |      |      |      |      |      |      |      |      |      |      |      |      |                 |         |      |       |      |       |      |       |      |       |      |       |      |       |      |       |      |       |
| 1010            | 1.98v    |   |                 |         |      |      |      |      |      |      |      |      |      |      |      |      |      |      |      |      |                 |         |      |       |      |       |      |       |      |       |      |       |      |       |      |       |      |       |
| 1011            | 2.08v    |   |                 |         |      |      |      |      |      |      |      |      |      |      |      |      |      |      |      |      |                 |         |      |       |      |       |      |       |      |       |      |       |      |       |      |       |      |       |
| 1100            | 3.06v    |   |                 |         |      |      |      |      |      |      |      |      |      |      |      |      |      |      |      |      |                 |         |      |       |      |       |      |       |      |       |      |       |      |       |      |       |      |       |
| 1101            | 3.24v    |   |                 |         |      |      |      |      |      |      |      |      |      |      |      |      |      |      |      |      |                 |         |      |       |      |       |      |       |      |       |      |       |      |       |      |       |      |       |
| 1110            | 3.42v    |   |                 |         |      |      |      |      |      |      |      |      |      |      |      |      |      |      |      |      |                 |         |      |       |      |       |      |       |      |       |      |       |      |       |      |       |      |       |
| 1111            | 3.60v    |   |                 |         |      |      |      |      |      |      |      |      |      |      |      |      |      |      |      |      |                 |         |      |       |      |       |      |       |      |       |      |       |      |       |      |       |      |       |
| 8               | DBKP     | <p>Cancel the write protection of the backup power domain.</p> <p>In the reset state, the RTC and backup domain registers should be protected to prevent illegal writing. This bit must be set to enable write access to these registers.</p> <p>0: Disable access to RTC and backup registers<br/>           1: Enable access to RTC and backup registers</p> <p><i>Note: This bit must remain 1 if the RTC clock is HSE/128.</i></p>  |                 |         |      |      |      |      |      |      |      |      |      |      |      |      |      |      |      |      |                 |         |      |       |      |       |      |       |      |       |      |       |      |       |      |       |      |       |
| 7:5             | PRS[2:0] | <p>PVD monitoring voltage selection.</p> <p>Combinations of different bits represent different voltage thresholds of the voltage detector.</p> <p>These bits need to be configured in conjunction with the MSB bit. For specific voltage thresholds, see the description of the MSB bit.</p> <p><i>NOTE: See the Electrical Characteristics section in the datasheet for detailed</i></p>   |                 |         |      |      |      |      |      |      |      |      |      |      |      |      |      |      |      |      |                 |         |      |       |      |       |      |       |      |       |      |       |      |       |      |       |      |       |

| Bit field | Name    | Description   |
|-----------|---------|---|
|           |         | <i>descriptions.</i>  |
| 4         | PVDEN   | Power supply voltage monitor (PVD) enabled.<br>0: Disable PVD<br>1: Enable PVD  |
| 3         | CSBVBAT | Clear STANDBY/VBAT bit.<br>always reads as 0<br>0: invalid<br>1: Clear PWR_CTRLSTS.SBF and PWR_CTRLSTS.VBATF standby bits (write)   |
| 2         | CWKUP   | Clear wakeup bit.<br>always reads as 0<br>0: invalid<br>1: Clear PWR_CTRLSTS.WKUPF wake-up bit after 2 system clock cycles (write)  |
| 1         | PDS     | Power-down deep-sleep bit.<br>Operates in conjunction with the LPS bit<br>0: Enters shutdown mode when the CPU enters deep sleep, the state of the voltage regulator is controlled by the LPS bit.<br>1: Enter standby mode when the CPU enters deep sleep. |
| 0         | LPS     | Low power consumption in deep sleep.<br>When PDS=0, cooperate with the PDS bit<br>0: Voltage regulator on in shutdown mode<br>1: Voltage regulator in low power mode in shutdown mode   |

#### 4.4.3 Power control status register(PWR\_CTRLSTS)

Address offset: 0x04

Reset value: 0x0000 0000 (not cleared when waking up from standby mode)

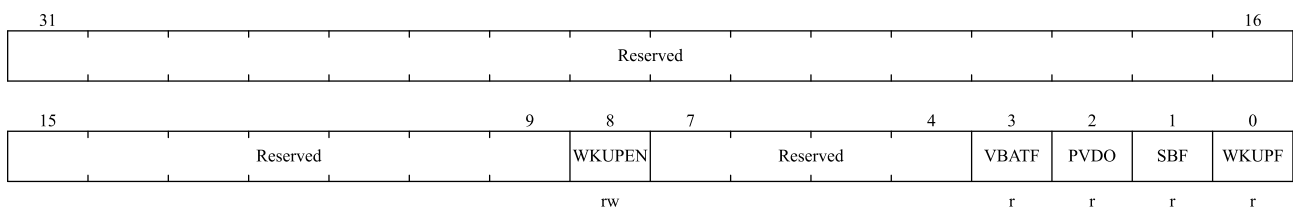

| Bit field | Name     | Description   |
|-----------|----------|---|
| 31:9      | Reserved | Reserved, the reset value must be maintained.   |
| 8         | WKUPEN   | Enable WKUP pin bit<br>0: The WKUP pin is a general purpose I/O. An event on the WKUP pin cannot wake the CPU from standby mode<br>1: WKUP pin is used to wake up CPU from standby mode, WKUP pin is forced to input pull-down configuration (rising edge on WKUP pin wakes up system from standby mode)<br><i>Note: This bit is cleared on system reset.</i> |
| 7:4       | Reserved | Reserved, the reset value must be maintained.   |

| Bit field | Name  | Description  |
|-----------|-------|--|
| 3         | VBATF | VBAT flag bit.<br>This bit is set by hardware and is only cleared by POR or PDR (power-on reset/power-down reset) or set by setting the PWR_CTRL.CSBVBAT bit.<br>0: The device is not in VBAT mode<br>1: The device is already in VBAT mode  |
| 2         | PVDO  | PVD output.<br>This bit is only valid when PVD is enabled by the PWR_CTRL.PVDEN bit<br>0: VDD/VDDA is higher than the PVD threshold selected by PWR_CTRL.PRS[2:0]<br>1: VDD/VDDA is lower than the PVD threshold selected by PWR_CTRL.PRS[2:0]<br><i>Note: PVD is stopped in standby mode. Therefore, after standby mode or after reset, this bit is 0 until the PWR_CTRL.PVDEN bit is set.</i>            |
| 1         | SBF   | Standby flag.<br>This bit is set by hardware and can only be cleared by POR/PDR (power-on/power-down reset) or by setting the PWR_CTRL.CSBVBAT bit.<br>0: The system is not in standby mode<br>1: The system enters standby mode   |
| 0         | WKUPF | Wake up flag.<br>This bit is set by hardware and can only be cleared by POR/PDR (power-on/power-down reset) or by setting the PWR_CTRL.CWKUP bit.<br>0: No wakeup event occurred<br>1: A wake-up event occurred on the WKUP pin or a RTC alarm event occurred.<br><i>Note: An additional event is detected when the WKUP pin is enabled (by setting the WKUPEN bit) when the WKUP pin is already high.</i> |

#### 4.4.4 Power control register 2 (PWR\_CTRL2)

Address offset: 0x08

Reset value: 0x0000 06E4 (reset by wakeup from STANDBY mode)

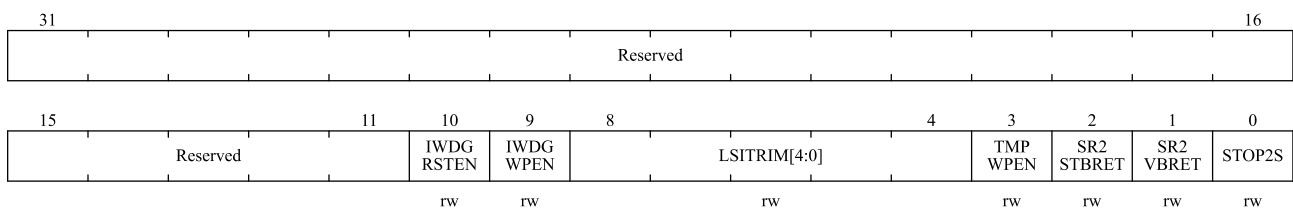

| Bit field | Name      | Description   |
|-----------|-----------|---|
| 31:11     | Reserved  | Reserved, the reset value must be maintained.   |
| 10        | IWDGRSTEN | Independent watchdog reset enable.<br>0: Independent watchdog cannot generate reset to RCC<br>1: Independent watchdog can generate reset to RCC |
| 9         | IWDGWPEN  | Independent watchdog wakeup enable.<br>0: Independent watchdog wakeup disable<br>1: Independent watchdog wake-up enable                         |

| Bit field | Name         | Description   |
|-----------|--------------|---|
| 8:4       | LSITRIM[4:0] | LSI correction value  |
| 3         | TMPWPEN      | TAMPER wake-up enable.<br>0: Disable<br>1: Enable   |
| 2         | SR2STBRET    | R-SRAM holds the enable bit in standby mode.<br>0: In standby mode, R-SRAM remains disable<br>1: In standby mode, R-SRAM remains enable |
| 1         | SR2VBRET     | R-SRAM holds the enable bit in VBAT mode.<br>0: In VBAT mode, R-SRAM remains disabled<br>1: In VBAT mode, R-SRAM remains enable         |
| 0         | STOP2S       | STOP2 mode enable bit.<br>0: Not used<br>1: Enable STOP2 mode   |

#### 4.4.5 Power control register 3 (PWR\_CTRL3)

Address offset: 0x0C

Reset value: 0x0000 5B70

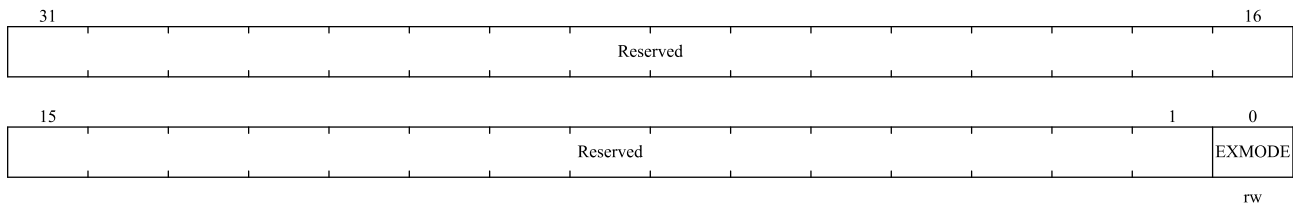

| Bit field | Name     | Description   |
|-----------|----------|---|
| 31:1      | Reserved | Reserved, the reset value must be maintained.                     |
| 0         | EXMODE   | Extended mode control bits.<br>0: Normal mode<br>1: Extended mode |

## 5 Backup registers (BKP)

### 5.1 Introduction

The backup memory is located in the backup domain, and is maintained by VBAT after the power supply VDD is turned off. BKP has a total of 42 16-bit registers that can be used to store and protect user application data. These 84 bytes are not affected by wake-up from system standby mode or system reset.

In addition, the BKP control register has a tamper detection function.

When the system is reset, all write operations are disabled to protect the backup domain from accidental operations. To enable, first set the `RCC_APB1PCLKEN.PWREN` and `RCC_APB1PCLKEN.BKPEN` bits to enable the power supply and the backup interface clock, and then set the `PWR_CTRL.DBKP` bit to enable the write operation to the backup register.

### 5.2 Main features

- Only need VBAT power supply to maintain 84-byte data backup register
- The effective level of the tamper source can be configured
- Can realize the control of tamper detection interrupt or event (`BKP_CTRLSTS`)

### 5.3 Function description

- **Power-down backup**
- **Tamper detection**

An tamper detection event clears all backup data register contents. The detection function of the TAMPER pin can be enabled by configuring the `BKP_CTRL.TP_EN` bit. It should be noted that the tamper detection signal is the logical AND of the level detection signal and the `BKP_CTRL.TP_EN` bit, so the tamper detection should be configured before the TAMPER pin is enabled.

When an tamper event is detected, the `BKP_CTRLSTS.TEF` bit is set to '1'. If the tamper detection interrupt is enabled (bit '1' in `BKP_CTRLSTS.TPINT_EN`), an interrupt will be generated.

In order to prevent the software from writing the backup data register when there is still an tamper event on the tamper detection pin, when the tamper event is cleared, the detection function of the tamper detection pin TAMPER should be turned off. After the backup data register operation is completed, set the `BKP_CTRL.TP_EN` bit to '1'.

The `BKP_CTRL.TP_ALEV` bit is used to set the active level of the tamper detection event. When `BKP_CTRL.TP_ALEV = 0` or `1`, if the TAMPER pin has been high or low before enabling, an additional tamper event will occur even though there is no rising or falling edge signal on the TAMPER pin. Therefore, the TAMPER pin should be connected to the correct level off-chip.

## 5.4 BKP registers

### 5.4.1 BKP register overview

The BKP register is a 16-bit addressable register.

Table 5-1 BKP Register overview

| Offset | Register    | 31       | 30 | 29 | 28 | 27 | 26 | 25 | 24 | 23 | 22 | 21 | 20 | 19 | 18 | 17 | 16 | 15        | 14  | 13       | 12 | 11 | 10 | 9        | 8       | 7       | 6     | 5 | 4 | 3 | 2 | 1 | 0 |
|--------|-------------|----------|----|----|----|----|----|----|----|----|----|----|----|----|----|----|----|-----------|-----|----------|----|----|----|----------|---------|---------|-------|---|---|---|---|---|---|
| 000h   | Reserved    |          |    |    |    |    |    |    |    |    |    |    |    |    |    |    |    |           |     |          |    |    |    |          |         |         |       |   |   |   |   |   |   |
| 004h   | BKP_DAT1    | Reserved |    |    |    |    |    |    |    |    |    |    |    |    |    |    |    | DAT[15:0] |     |          |    |    |    |          |         |         |       |   |   |   |   |   |   |
|        | Reset Value | 0        | 0  | 0  | 0  | 0  | 0  | 0  | 0  | 0  | 0  | 0  | 0  | 0  | 0  | 0  | 0  | 0         | 0   | 0        | 0  | 0  | 0  | 0        | 0       | 0       | 0     | 0 | 0 | 0 | 0 | 0 |   |
| 008h   | BKP_DAT2    | Reserved |    |    |    |    |    |    |    |    |    |    |    |    |    |    |    | DAT[15:0] |     |          |    |    |    |          |         |         |       |   |   |   |   |   |   |
|        | Reset Value | 0        | 0  | 0  | 0  | 0  | 0  | 0  | 0  | 0  | 0  | 0  | 0  | 0  | 0  | 0  | 0  | 0         | 0   | 0        | 0  | 0  | 0  | 0        | 0       | 0       | 0     | 0 | 0 | 0 | 0 | 0 |   |
| 00Ch   | BKP_DAT3    | Reserved |    |    |    |    |    |    |    |    |    |    |    |    |    |    |    | DAT[15:0] |     |          |    |    |    |          |         |         |       |   |   |   |   |   |   |
|        | Reset Value | 0        | 0  | 0  | 0  | 0  | 0  | 0  | 0  | 0  | 0  | 0  | 0  | 0  | 0  | 0  | 0  | 0         | 0   | 0        | 0  | 0  | 0  | 0        | 0       | 0       | 0     | 0 | 0 | 0 | 0 | 0 |   |
| 010h   | BKP_DAT4    | Reserved |    |    |    |    |    |    |    |    |    |    |    |    |    |    |    | DAT[15:0] |     |          |    |    |    |          |         |         |       |   |   |   |   |   |   |
|        | Reset Value | 0        | 0  | 0  | 0  | 0  | 0  | 0  | 0  | 0  | 0  | 0  | 0  | 0  | 0  | 0  | 0  | 0         | 0   | 0        | 0  | 0  | 0  | 0        | 0       | 0       | 0     | 0 | 0 | 0 | 0 | 0 |   |
| 014h   | BKP_DAT5    | Reserved |    |    |    |    |    |    |    |    |    |    |    |    |    |    |    | DAT[15:0] |     |          |    |    |    |          |         |         |       |   |   |   |   |   |   |
|        | Reset Value | 0        | 0  | 0  | 0  | 0  | 0  | 0  | 0  | 0  | 0  | 0  | 0  | 0  | 0  | 0  | 0  | 0         | 0   | 0        | 0  | 0  | 0  | 0        | 0       | 0       | 0     | 0 | 0 | 0 | 0 | 0 |   |
| 018h   | BKP_DAT6    | Reserved |    |    |    |    |    |    |    |    |    |    |    |    |    |    |    | DAT[15:0] |     |          |    |    |    |          |         |         |       |   |   |   |   |   |   |
|        | Reset Value | 0        | 0  | 0  | 0  | 0  | 0  | 0  | 0  | 0  | 0  | 0  | 0  | 0  | 0  | 0  | 0  | 0         | 0   | 0        | 0  | 0  | 0  | 0        | 0       | 0       | 0     | 0 | 0 | 0 | 0 | 0 |   |
| 01Ch   | BKP_DAT7    | Reserved |    |    |    |    |    |    |    |    |    |    |    |    |    |    |    | DAT[15:0] |     |          |    |    |    |          |         |         |       |   |   |   |   |   |   |
|        | Reset Value | 0        | 0  | 0  | 0  | 0  | 0  | 0  | 0  | 0  | 0  | 0  | 0  | 0  | 0  | 0  | 0  | 0         | 0   | 0        | 0  | 0  | 0  | 0        | 0       | 0       | 0     | 0 | 0 | 0 | 0 | 0 |   |
| 020h   | BKP_DAT8    | Reserved |    |    |    |    |    |    |    |    |    |    |    |    |    |    |    | DAT[15:0] |     |          |    |    |    |          |         |         |       |   |   |   |   |   |   |
|        | Reset Value | 0        | 0  | 0  | 0  | 0  | 0  | 0  | 0  | 0  | 0  | 0  | 0  | 0  | 0  | 0  | 0  | 0         | 0   | 0        | 0  | 0  | 0  | 0        | 0       | 0       | 0     | 0 | 0 | 0 | 0 | 0 |   |
| 024h   | BKP_DAT9    | Reserved |    |    |    |    |    |    |    |    |    |    |    |    |    |    |    | DAT[15:0] |     |          |    |    |    |          |         |         |       |   |   |   |   |   |   |
|        | Reset Value | 0        | 0  | 0  | 0  | 0  | 0  | 0  | 0  | 0  | 0  | 0  | 0  | 0  | 0  | 0  | 0  | 0         | 0   | 0        | 0  | 0  | 0  | 0        | 0       | 0       | 0     | 0 | 0 | 0 | 0 | 0 |   |
| 028h   | BKP_DAT10   | Reserved |    |    |    |    |    |    |    |    |    |    |    |    |    |    |    | DAT[15:0] |     |          |    |    |    |          |         |         |       |   |   |   |   |   |   |
|        | Reset Value | 0        | 0  | 0  | 0  | 0  | 0  | 0  | 0  | 0  | 0  | 0  | 0  | 0  | 0  | 0  | 0  | 0         | 0   | 0        | 0  | 0  | 0  | 0        | 0       | 0       | 0     | 0 | 0 | 0 | 0 | 0 |   |
| 02Ch   | Reserved    |          |    |    |    |    |    |    |    |    |    |    |    |    |    |    |    |           |     |          |    |    |    |          |         |         |       |   |   |   |   |   |   |
| 030h   | BKP_CTRL    | Reserved |    |    |    |    |    |    |    |    |    |    |    |    |    |    |    |           |     |          |    |    |    |          |         | TP_ALEV | TP_EN |   |   |   |   |   |   |
|        | Reset Value |          |    |    |    |    |    |    |    |    |    |    |    |    |    |    |    |           |     |          |    |    |    |          |         | 0       | 0     |   |   |   |   |   |   |
| 034h   | BKP_CTRLSTS | Reserved |    |    |    |    |    |    |    |    |    |    |    |    |    |    |    | TINTF     | TEF | Reserved |    |    |    | TPINT_EN | CLRTINT | CLRTE   |       |   |   |   |   |   |   |
|        | Reset Value |          |    |    |    |    |    |    |    |    |    |    |    |    |    |    |    | 0         | 0   |          |    |    |    | 0        | 0       | 0       |       |   |   |   |   |   |   |
| 038h   | Reserved    |          |    |    |    |    |    |    |    |    |    |    |    |    |    |    |    |           |     |          |    |    |    |          |         |         |       |   |   |   |   |   |   |
| 03Ch   | Reserved    |          |    |    |    |    |    |    |    |    |    |    |    |    |    |    |    |           |     |          |    |    |    |          |         |         |       |   |   |   |   |   |   |
| 040h   | BKP_DAT11   | Reserved |    |    |    |    |    |    |    |    |    |    |    |    |    |    |    | DAT[15:0] |     |          |    |    |    |          |         |         |       |   |   |   |   |   |   |
|        | Reset Value | 0        | 0  | 0  | 0  | 0  | 0  | 0  | 0  | 0  | 0  | 0  | 0  | 0  | 0  | 0  | 0  | 0         | 0   | 0        | 0  | 0  | 0  | 0        | 0       | 0       | 0     | 0 | 0 | 0 | 0 |   |   |
| 044h   | BKP_DAT12   | Reserved |    |    |    |    |    |    |    |    |    |    |    |    |    |    |    | DAT[15:0] |     |          |    |    |    |          |         |         |       |   |   |   |   |   |   |

| Offset | Register    | 31       | 30 | 29 | 28 | 27 | 26 | 25 | 24 | 23 | 22 | 21 | 20 | 19 | 18 | 17 | 16 | 15        | 14 | 13 | 12 | 11 | 10 | 9 | 8 | 7 | 6 | 5 | 4 | 3 | 2 | 1 | 0 |
|--------|-------------|----------|----|----|----|----|----|----|----|----|----|----|----|----|----|----|----|-----------|----|----|----|----|----|---|---|---|---|---|---|---|---|---|---|
|        | Reset Value |          |    |    |    |    |    |    |    |    |    |    |    |    |    |    |    | 0         | 0  | 0  | 0  | 0  | 0  | 0 | 0 | 0 | 0 | 0 | 0 | 0 | 0 | 0 | 0 |
| 048h   | BKP_DAT13   | Reserved |    |    |    |    |    |    |    |    |    |    |    |    |    |    |    | DAT[15:0] |    |    |    |    |    |   |   |   |   |   |   |   |   |   |   |
|        | Reset Value |          |    |    |    |    |    |    |    |    |    |    |    |    |    |    |    | 0         | 0  | 0  | 0  | 0  | 0  | 0 | 0 | 0 | 0 | 0 | 0 | 0 | 0 | 0 | 0 |
| 04Ch   | BKP_DAT14   | Reserved |    |    |    |    |    |    |    |    |    |    |    |    |    |    |    | DAT[15:0] |    |    |    |    |    |   |   |   |   |   |   |   |   |   |   |
|        | Reset Value |          |    |    |    |    |    |    |    |    |    |    |    |    |    |    |    | 0         | 0  | 0  | 0  | 0  | 0  | 0 | 0 | 0 | 0 | 0 | 0 | 0 | 0 | 0 | 0 |
| 050h   | BKP_DAT15   | Reserved |    |    |    |    |    |    |    |    |    |    |    |    |    |    |    | DAT[15:0] |    |    |    |    |    |   |   |   |   |   |   |   |   |   |   |
|        | Reset Value |          |    |    |    |    |    |    |    |    |    |    |    |    |    |    |    | 0         | 0  | 0  | 0  | 0  | 0  | 0 | 0 | 0 | 0 | 0 | 0 | 0 | 0 | 0 | 0 |
| 054h   | BKP_DAT16   | Reserved |    |    |    |    |    |    |    |    |    |    |    |    |    |    |    | DAT[15:0] |    |    |    |    |    |   |   |   |   |   |   |   |   |   |   |
|        | Reset Value |          |    |    |    |    |    |    |    |    |    |    |    |    |    |    |    | 0         | 0  | 0  | 0  | 0  | 0  | 0 | 0 | 0 | 0 | 0 | 0 | 0 | 0 | 0 | 0 |
| 058h   | BKP_DAT17   | Reserved |    |    |    |    |    |    |    |    |    |    |    |    |    |    |    | DAT[15:0] |    |    |    |    |    |   |   |   |   |   |   |   |   |   |   |
|        | Reset Value |          |    |    |    |    |    |    |    |    |    |    |    |    |    |    |    | 0         | 0  | 0  | 0  | 0  | 0  | 0 | 0 | 0 | 0 | 0 | 0 | 0 | 0 | 0 | 0 |
| 05Ch   | BKP_DAT18   | Reserved |    |    |    |    |    |    |    |    |    |    |    |    |    |    |    | DAT[15:0] |    |    |    |    |    |   |   |   |   |   |   |   |   |   |   |
|        | Reset Value |          |    |    |    |    |    |    |    |    |    |    |    |    |    |    |    | 0         | 0  | 0  | 0  | 0  | 0  | 0 | 0 | 0 | 0 | 0 | 0 | 0 | 0 | 0 | 0 |
| 060h   | BKP_DAT19   | Reserved |    |    |    |    |    |    |    |    |    |    |    |    |    |    |    | DAT[15:0] |    |    |    |    |    |   |   |   |   |   |   |   |   |   |   |
|        | Reset Value |          |    |    |    |    |    |    |    |    |    |    |    |    |    |    |    | 0         | 0  | 0  | 0  | 0  | 0  | 0 | 0 | 0 | 0 | 0 | 0 | 0 | 0 | 0 | 0 |
| 064h   | BKP_DAT20   | Reserved |    |    |    |    |    |    |    |    |    |    |    |    |    |    |    | DAT[15:0] |    |    |    |    |    |   |   |   |   |   |   |   |   |   |   |
|        | Reset Value |          |    |    |    |    |    |    |    |    |    |    |    |    |    |    |    | 0         | 0  | 0  | 0  | 0  | 0  | 0 | 0 | 0 | 0 | 0 | 0 | 0 | 0 | 0 | 0 |
| 068h   | BKP_DAT21   | Reserved |    |    |    |    |    |    |    |    |    |    |    |    |    |    |    | DAT[15:0] |    |    |    |    |    |   |   |   |   |   |   |   |   |   |   |
|        | Reset Value |          |    |    |    |    |    |    |    |    |    |    |    |    |    |    |    | 0         | 0  | 0  | 0  | 0  | 0  | 0 | 0 | 0 | 0 | 0 | 0 | 0 | 0 | 0 | 0 |
| 06Ch   | BKP_DAT22   | Reserved |    |    |    |    |    |    |    |    |    |    |    |    |    |    |    | DAT[15:0] |    |    |    |    |    |   |   |   |   |   |   |   |   |   |   |
|        | Reset Value |          |    |    |    |    |    |    |    |    |    |    |    |    |    |    |    | 0         | 0  | 0  | 0  | 0  | 0  | 0 | 0 | 0 | 0 | 0 | 0 | 0 | 0 | 0 | 0 |
| 070h   | BKP_DAT23   | Reserved |    |    |    |    |    |    |    |    |    |    |    |    |    |    |    | DAT[15:0] |    |    |    |    |    |   |   |   |   |   |   |   |   |   |   |
|        | Reset Value |          |    |    |    |    |    |    |    |    |    |    |    |    |    |    |    | 0         | 0  | 0  | 0  | 0  | 0  | 0 | 0 | 0 | 0 | 0 | 0 | 0 | 0 | 0 | 0 |
| 074h   | BKP_DAT24   | Reserved |    |    |    |    |    |    |    |    |    |    |    |    |    |    |    | DAT[15:0] |    |    |    |    |    |   |   |   |   |   |   |   |   |   |   |
|        | Reset Value |          |    |    |    |    |    |    |    |    |    |    |    |    |    |    |    | 0         | 0  | 0  | 0  | 0  | 0  | 0 | 0 | 0 | 0 | 0 | 0 | 0 | 0 | 0 | 0 |
| 078h   | BKP_DAT25   | Reserved |    |    |    |    |    |    |    |    |    |    |    |    |    |    |    | DAT[15:0] |    |    |    |    |    |   |   |   |   |   |   |   |   |   |   |
|        | Reset Value |          |    |    |    |    |    |    |    |    |    |    |    |    |    |    |    | 0         | 0  | 0  | 0  | 0  | 0  | 0 | 0 | 0 | 0 | 0 | 0 | 0 | 0 | 0 | 0 |
| 07Ch   | BKP_DAT26   | Reserved |    |    |    |    |    |    |    |    |    |    |    |    |    |    |    | DAT[15:0] |    |    |    |    |    |   |   |   |   |   |   |   |   |   |   |
|        | Reset Value |          |    |    |    |    |    |    |    |    |    |    |    |    |    |    |    | 0         | 0  | 0  | 0  | 0  | 0  | 0 | 0 | 0 | 0 | 0 | 0 | 0 | 0 | 0 | 0 |
| 080h   | BKP_DAT27   | Reserved |    |    |    |    |    |    |    |    |    |    |    |    |    |    |    | DAT[15:0] |    |    |    |    |    |   |   |   |   |   |   |   |   |   |   |
|        | Reset Value |          |    |    |    |    |    |    |    |    |    |    |    |    |    |    |    | 0         | 0  | 0  | 0  | 0  | 0  | 0 | 0 | 0 | 0 | 0 | 0 | 0 | 0 | 0 | 0 |
| 084h   | BKP_DAT28   | Reserved |    |    |    |    |    |    |    |    |    |    |    |    |    |    |    | DAT[15:0] |    |    |    |    |    |   |   |   |   |   |   |   |   |   |   |
|        | Reset Value |          |    |    |    |    |    |    |    |    |    |    |    |    |    |    |    | 0         | 0  | 0  | 0  | 0  | 0  | 0 | 0 | 0 | 0 | 0 | 0 | 0 | 0 | 0 | 0 |
| 088h   | BKP_DAT29   | Reserved |    |    |    |    |    |    |    |    |    |    |    |    |    |    |    | DAT[15:0] |    |    |    |    |    |   |   |   |   |   |   |   |   |   |   |
|        | Reset Value |          |    |    |    |    |    |    |    |    |    |    |    |    |    |    |    | 0         | 0  | 0  | 0  | 0  | 0  | 0 | 0 | 0 | 0 | 0 | 0 | 0 | 0 | 0 | 0 |
| 08Ch   | BKP_DAT30   | Reserved |    |    |    |    |    |    |    |    |    |    |    |    |    |    |    | DAT[15:0] |    |    |    |    |    |   |   |   |   |   |   |   |   |   |   |
|        | Reset Value |          |    |    |    |    |    |    |    |    |    |    |    |    |    |    |    | 0         | 0  | 0  | 0  | 0  | 0  | 0 | 0 | 0 | 0 | 0 | 0 | 0 | 0 | 0 | 0 |
| 090h   | BKP_DAT31   | Reserved |    |    |    |    |    |    |    |    |    |    |    |    |    |    |    | DAT[15:0] |    |    |    |    |    |   |   |   |   |   |   |   |   |   |   |
|        | Reset Value |          |    |    |    |    |    |    |    |    |    |    |    |    |    |    |    | 0         | 0  | 0  | 0  | 0  | 0  | 0 | 0 | 0 | 0 | 0 | 0 | 0 | 0 | 0 | 0 |
| 094h   | BKP_DAT32   | Reserved |    |    |    |    |    |    |    |    |    |    |    |    |    |    |    | DAT[15:0] |    |    |    |    |    |   |   |   |   |   |   |   |   |   |   |
|        | Reset Value |          |    |    |    |    |    |    |    |    |    |    |    |    |    |    |    | 0         | 0  | 0  | 0  | 0  | 0  | 0 | 0 | 0 | 0 | 0 | 0 | 0 | 0 | 0 | 0 |
| 098h   | BKP_DAT33   | Reserved |    |    |    |    |    |    |    |    |    |    |    |    |    |    |    | DAT[15:0] |    |    |    |    |    |   |   |   |   |   |   |   |   |   |   |
|        | Reset Value |          |    |    |    |    |    |    |    |    |    |    |    |    |    |    |    | 0         | 0  | 0  | 0  | 0  | 0  | 0 | 0 | 0 | 0 | 0 | 0 | 0 | 0 | 0 | 0 |
| 09Ch   | BKP_DAT34   | Reserved |    |    |    |    |    |    |    |    |    |    |    |    |    |    |    | DAT[15:0] |    |    |    |    |    |   |   |   |   |   |   |   |   |   |   |
|        | Reset Value |          |    |    |    |    |    |    |    |    |    |    |    |    |    |    |    | 0         | 0  | 0  | 0  | 0  | 0  | 0 | 0 | 0 | 0 | 0 | 0 | 0 | 0 | 0 | 0 |
| 0A0h   | BKP_DAT35   | Reserved |    |    |    |    |    |    |    |    |    |    |    |    |    |    |    | DAT[15:0] |    |    |    |    |    |   |   |   |   |   |   |   |   |   |   |

| Offset | Register    | 31       | 30 | 29 | 28 | 27 | 26 | 25 | 24 | 23 | 22 | 21 | 20 | 19 | 18 | 17 | 16 | 15        | 14 | 13 | 12 | 11 | 10 | 9 | 8 | 7 | 6 | 5 | 4 | 3 | 2 | 1 | 0 |   |   |   |   |   |   |   |   |   |   |   |   |   |   |   |
|--------|-------------|----------|----|----|----|----|----|----|----|----|----|----|----|----|----|----|----|-----------|----|----|----|----|----|---|---|---|---|---|---|---|---|---|---|---|---|---|---|---|---|---|---|---|---|---|---|---|---|---|
|        | Reset Value | Reserved |    |    |    |    |    |    |    |    |    |    |    |    |    |    |    | 0         | 0  | 0  | 0  | 0  | 0  | 0 | 0 | 0 | 0 | 0 | 0 | 0 | 0 | 0 | 0 | 0 | 0 | 0 | 0 | 0 | 0 | 0 | 0 | 0 | 0 | 0 | 0 | 0 | 0 | 0 |
| 0A4h   | BKP_DAT36   | Reserved |    |    |    |    |    |    |    |    |    |    |    |    |    |    |    | DAT[15:0] |    |    |    |    |    |   |   |   |   |   |   |   |   |   |   |   |   |   |   |   |   |   |   |   |   |   |   |   |   |   |
|        | Reset Value | Reserved |    |    |    |    |    |    |    |    |    |    |    |    |    |    |    | 0         | 0  | 0  | 0  | 0  | 0  | 0 | 0 | 0 | 0 | 0 | 0 | 0 | 0 | 0 | 0 | 0 | 0 | 0 | 0 | 0 | 0 | 0 | 0 | 0 | 0 | 0 | 0 | 0 | 0 | 0 |
| 0A8h   | BKP_DAT37   | Reserved |    |    |    |    |    |    |    |    |    |    |    |    |    |    |    | DAT[15:0] |    |    |    |    |    |   |   |   |   |   |   |   |   |   |   |   |   |   |   |   |   |   |   |   |   |   |   |   |   |   |
|        | Reset Value | Reserved |    |    |    |    |    |    |    |    |    |    |    |    |    |    |    | 0         | 0  | 0  | 0  | 0  | 0  | 0 | 0 | 0 | 0 | 0 | 0 | 0 | 0 | 0 | 0 | 0 | 0 | 0 | 0 | 0 | 0 | 0 | 0 | 0 | 0 | 0 | 0 | 0 | 0 | 0 |
| 0ACh   | BKP_DAT38   | Reserved |    |    |    |    |    |    |    |    |    |    |    |    |    |    |    | DAT[15:0] |    |    |    |    |    |   |   |   |   |   |   |   |   |   |   |   |   |   |   |   |   |   |   |   |   |   |   |   |   |   |
|        | Reset Value | Reserved |    |    |    |    |    |    |    |    |    |    |    |    |    |    |    | 0         | 0  | 0  | 0  | 0  | 0  | 0 | 0 | 0 | 0 | 0 | 0 | 0 | 0 | 0 | 0 | 0 | 0 | 0 | 0 | 0 | 0 | 0 | 0 | 0 | 0 | 0 | 0 | 0 | 0 | 0 |
| 0B0h   | BKP_DAT39   | Reserved |    |    |    |    |    |    |    |    |    |    |    |    |    |    |    | DAT[15:0] |    |    |    |    |    |   |   |   |   |   |   |   |   |   |   |   |   |   |   |   |   |   |   |   |   |   |   |   |   |   |
|        | Reset Value | Reserved |    |    |    |    |    |    |    |    |    |    |    |    |    |    |    | 0         | 0  | 0  | 0  | 0  | 0  | 0 | 0 | 0 | 0 | 0 | 0 | 0 | 0 | 0 | 0 | 0 | 0 | 0 | 0 | 0 | 0 | 0 | 0 | 0 | 0 | 0 | 0 | 0 | 0 | 0 |
| 0B4h   | BKP_DAT40   | Reserved |    |    |    |    |    |    |    |    |    |    |    |    |    |    |    | DAT[15:0] |    |    |    |    |    |   |   |   |   |   |   |   |   |   |   |   |   |   |   |   |   |   |   |   |   |   |   |   |   |   |
|        | Reset Value | Reserved |    |    |    |    |    |    |    |    |    |    |    |    |    |    |    | 0         | 0  | 0  | 0  | 0  | 0  | 0 | 0 | 0 | 0 | 0 | 0 | 0 | 0 | 0 | 0 | 0 | 0 | 0 | 0 | 0 | 0 | 0 | 0 | 0 | 0 | 0 | 0 | 0 | 0 | 0 |
| 0B8h   | BKP_DAT41   | Reserved |    |    |    |    |    |    |    |    |    |    |    |    |    |    |    | DAT[15:0] |    |    |    |    |    |   |   |   |   |   |   |   |   |   |   |   |   |   |   |   |   |   |   |   |   |   |   |   |   |   |
|        | Reset Value | Reserved |    |    |    |    |    |    |    |    |    |    |    |    |    |    |    | 0         | 0  | 0  | 0  | 0  | 0  | 0 | 0 | 0 | 0 | 0 | 0 | 0 | 0 | 0 | 0 | 0 | 0 | 0 | 0 | 0 | 0 | 0 | 0 | 0 | 0 | 0 | 0 | 0 | 0 | 0 |
| 0BCh   | BKP_DAT42   | Reserved |    |    |    |    |    |    |    |    |    |    |    |    |    |    |    | DAT[15:0] |    |    |    |    |    |   |   |   |   |   |   |   |   |   |   |   |   |   |   |   |   |   |   |   |   |   |   |   |   |   |
|        | Reset Value | Reserved |    |    |    |    |    |    |    |    |    |    |    |    |    |    |    | 0         | 0  | 0  | 0  | 0  | 0  | 0 | 0 | 0 | 0 | 0 | 0 | 0 | 0 | 0 | 0 | 0 | 0 | 0 | 0 | 0 | 0 | 0 | 0 | 0 | 0 | 0 | 0 | 0 | 0 | 0 |

### 5.4.2 Backup Data Register x (BKP\_DATx) (x = 1 ... 42)

Address offset: 0x04 to 0x28, 0x40 to 0xBC

Reset value: 0x0000 0000

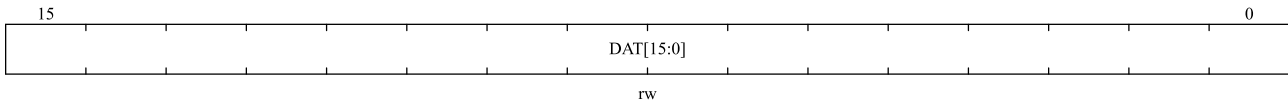

| Bit field | Name      | Description  |
|-----------|-----------|--|
| 15:0      | DAT[15:0] | backup data<br>These bits can be used to write user data.<br>Note: BKP_DATx registers are not reset by system reset, power reset, wake-up from standby mode. They can be reset by a backup domain reset or (if the tamper detection pin TAMPER function is enabled) by a tamper pin event. |

### 5.4.3 Backup Control Register (BKP\_CTRL)

Address offset: 0x30

Reset value: 0x0000 0000

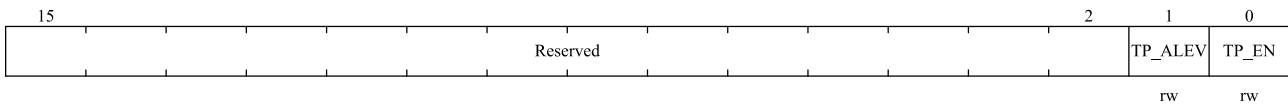

| Bit field | Name     | Description   |
|-----------|----------|---|
| 15:2      | Reserved | Reserved, the reset value must be maintained.   |
| 1         | TP_ALEV  | Tamper detection TAMPER pin active level<br>0: A high level on the tamper detection TAMPER pin clears all data backup registers<br>1: A low level on the tamper detection TAMPER pin clears all data backup registers |

| Bit field | Name  | Description   |
|-----------|-------|---|
| 0         | TP_EN | Start tamper detection TAMPER pin<br>0: Tamper detection TAMPER pin is used as a general IO port<br>1: Enable the tamper detection pin for tamper detection |

*Note: It is always safe to set the BKP\_CTRL.TP\_ALEV and BKP\_CTRL.TP\_EN bits at the same time. However, clearing both at the same time produces a false tamper event. Therefore, it is recommended to change the state of the BKP\_CTRL.TP\_ALEV bit only when BKP\_CTRL.TP\_EN is 0.*

#### 5.4.4 Backup Control/Status Register (BKP\_CTRLSTS)

Address offset: 0x34

Reset value: 0x0000 0000

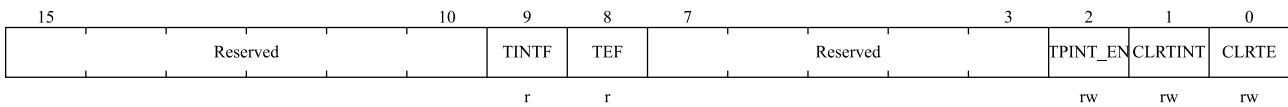

| Bit field | Name     | Description   |
|-----------|----------|---|
| 15:10     | Reserved | Reserved, the reset value must be maintained.   |
| 9         | TINTF    | Tamper interrupt flag<br>This bit is set by hardware when an tamper event is detected and the TPINT_EN bit is 1. This flag is cleared by writing a 1 to the CLRTINT bit (which also clears the interrupt). This bit is also cleared if the TPINT_EN bit is cleared.<br>0: No tamper interrupt<br>1: Generate tamper interrupt<br><i>Note: This bit is only reset after system reset or wake-up from standby mode</i>                |
| 8         | TEF      | Tamper event sign<br>This bit is set by hardware when an tamper event is detected. This flag can be cleared by writing a 1 to the CLRTE bit<br>0: No tamper event<br>1: Tamper event detected<br><i>Note: A tamper event resets all BKP_DATx registers. All BKP_DATx registers remain reset as long as TEF is 1. When this bit is set to 1, if a write operation is performed to BKP_DATx, the written value will not be saved.</i> |
| 7:3       | Reserved | Reserved, the reset value must be maintained.   |
| 2         | TPINT_EN | Allow tamper of TAMPER pin interrupt<br>0: Disable tamper detection interrupt<br>1: Tamper detection interrupt is enabled (the TP_EN bit of the BKP_CTRL register must also be set to 1)<br><i>Note 1: Intrusive interrupts cannot wake up the system core from low power modes.</i><br><i>Note 2: This bit is reset only after system reset or wake-up from standby mode.</i>  |
| 1         | CLRTINT  | Clear Tamper Detection Interrupt<br>This bit can only be written, and the read value is 0.<br>0: invalid  |

| Bit field | Name  | Description  |
|-----------|-------|--|
|           |       | 1: Clear the tamper detection interrupt and TINTF tamper detection interrupt flags   |
| 0         | CLRTE | Clear tamper detection events<br>This bit can only be written, and the read value is 0.<br>0: invalid<br>1: Clear the TEF tamper detection event flag (and reset the tamper detector). |

## 6 Reset and clock control (RCC)

### 6.1 Reset Control Unit

Supports the following three types of reset:

- Power Reset
- System Reset
- Backup domain Reset

#### 6.1.1 Power reset

A Power reset occurs in the following circumstances:

- Power-on reset (POR reset).
- Power-down reset(PDR reset).
- When exiting STANDBY mode.

Power resets will reset all registers except the backup domain (see Figure 4-1).

The reset source in the figure will finally act on the NRST pin and remain low during the reset process. The reset entry vector is fixed at address 0x0000\_0004. For more details, see Table 2-1 vector table.

#### 6.1.2 System reset

Except the reset flags in the Control/Status Register (RCC\_CTRLSTS) and the registers in the backup domain (see Figure 4-1), a system reset sets all registers to their reset values.

A system reset is generated when one of the following events occurs:

- A low level on the NRST pin (external reset)
- Window watchdog end of count condition (WWDG reset)
- Independent watchdog end of count condition (IWDG reset)
- Software reset (SW reset)
- Low power management reset
- Power reset
- MMU protection reset
- RAM parity error reset
- Backup domain EMC reset
- Retention domain EMC reset
- BOR reset

The source of the reset event can be identified by looking at the reset status flag bits in the RCC\_CTRLSTS control

status register.

### 6.1.2.1 Software reset

A software reset can be generated by setting the SYSRESETREQ bit in Cortex™-M4 Application Interrupt and Reset Control Register. Refer to Cortex™-M4 technical reference manual for further information.

### 6.1.2.2 Low-power management reset

Low-power management reset can be generated by using the following methods:

- Generate low power management reset when entering STANDBY mode: This reset is enabled by setting the nRST\_STDBY bit in the user option byte. At this time, even if the procedure to enter STANDBY mode is performed, the system will be reset instead of entering STANDBY mode.
- Generate low power management reset when entering STOP0/STOP2 mode: This reset is enabled by setting the nRST\_STOP bit in the user option byte. At this time, even if the process to enter STOP0/STOP2 mode is performed, the system will be reset instead of entering STOP0/STOP2 mode.

The system reset signal provided to the chip is output on the NRST pin. The pulse generator guarantees a minimum reset pulse duration of 20µs for each reset source (external or internal). For external reset, the reset pulse is generated while the NRST pin is asserted low.

The Figure below shows the system reset generation circuit.

Figure 6-1 System reset generation

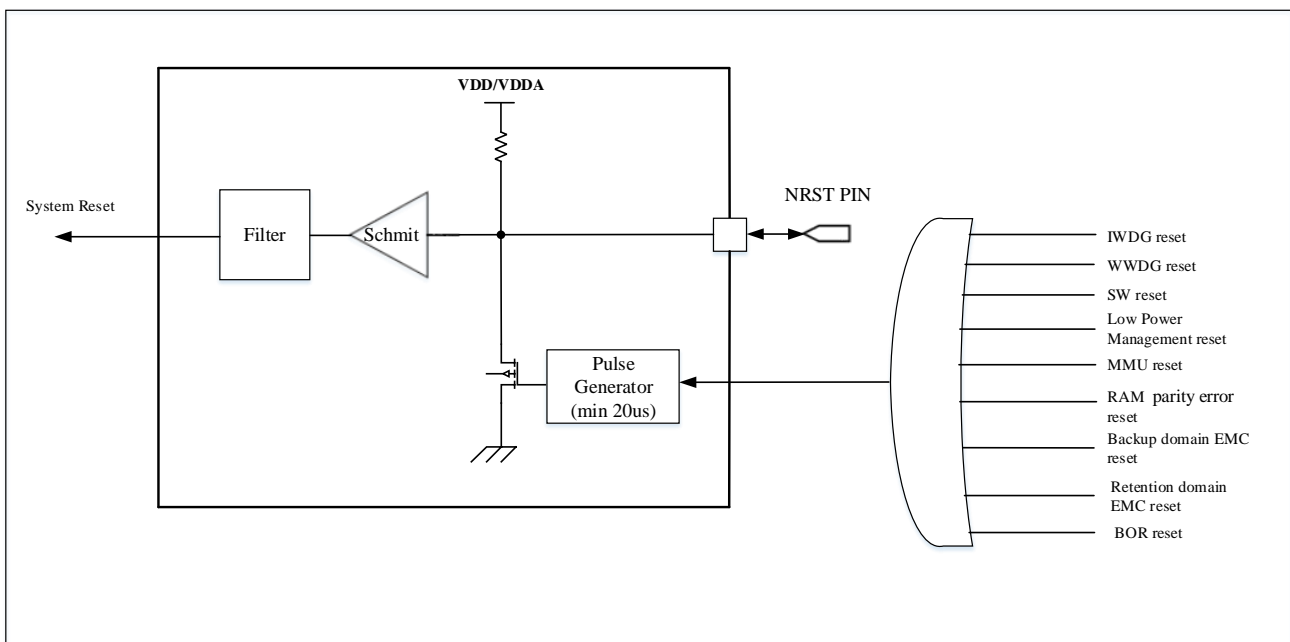

### 6.1.3 Backup domain reset

The backup domain has two dedicated resets that only affect the backup domain (see Figure 4-1 Power Supply Block Diagram).

The backup domain reset is generated when one of the following events occurs:

- Software reset: The backup domain reset can be generated by setting the RCC\_BDCTRL.BDSFTRST bit.

- Under the premise that both VDD and VBAT are powered off, the backup area will be reset only when VDD or VBAT is powered on.

## 6.2 Clock control unit

Three different clock sources can be used to drive the system clock (SYSCLK):

- HSI oscillator clock;
- HSE oscillator clock;
- PLL clock;

The devices have the following two secondary clock sources:

- LSI: 40 kHz low-speed internal RC which drives independent watchdog (IWDG) can be selected by software to drive RTC. RTC is used to automatically wake up the system from STOP0/STOP2/STANDBY mode.
- LSE: 32.768 kHz low-speed external crystal can also be selected by software to drive RTC(RTCCLK).

Each clock source can be turned on or off independently when it is not used to optimize power consumption.

Several prescalers can be used to configure the frequencies of the AHB, the high-speed APB (APB2), and the low-speed APB (APB1) domains. The maximum frequencies of the AHB, APB2, and APB1 domains are 144MHz, 72MHz, and 36MHz respectively. The clock frequency of the SDIO interface is fixed at HCLK/2.

RCC provides the Cortex System Timer (SysTick) external clock with the AHB clock (HCLK). The ADC clock is generated by dividing the AHB clock or PLL clock.

The clock frequencies of timers are automatically set by hardware. There are two scenarios:

- If the APB prescaler is 1, the timer clock frequencies are set to the same frequency as that of the APB domain to which the timers are connected.
- Otherwise, they are set to twice the frequency of the APB domain to which the timers are connected.

FCLK is the free-running clock of Cortex™-M4F. For more details, refer to the ARM Cortex™-M4 technical reference manual.

## 6.2.1 Clock Tree Diagram

Figure 6-2 Clock Tree

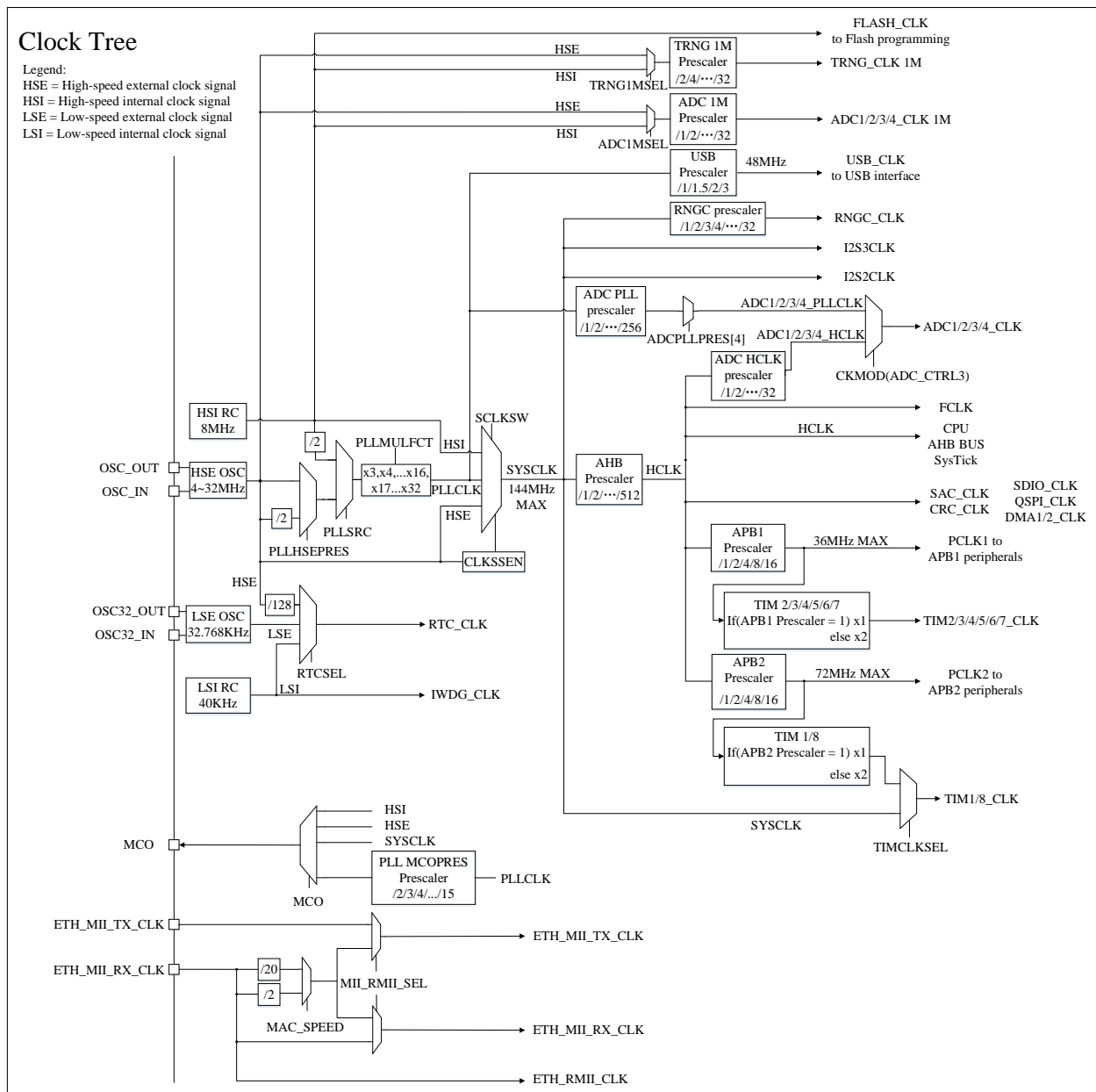

1. When HSI is used as the input of the PLL clock, the maximum frequency that the system clock can get is 128MHz.
2. For more details about the internal and external clock source characteristics, please refer to the "Electrical Characteristics" section in the product datasheet.
3. When PLL is selected as system clock source, PLL minimum clock output is 32MHz.

## 6.2.2 HSE clock

The high-speed external clock signal (HSE) can be generated from the following two clock sources:

- HSE external crystal/ceramic resonator

- HSE user external clock

To reduce distortion of the clock output and shorten the start-up Stabilize time, the crystal/ceramic resonator and load capacitor must be placed as close as possible to the oscillator pins. The load capacitance value must be adjusted according to the chosen oscillator.

Figure 6-3 HSE/LSE clock source

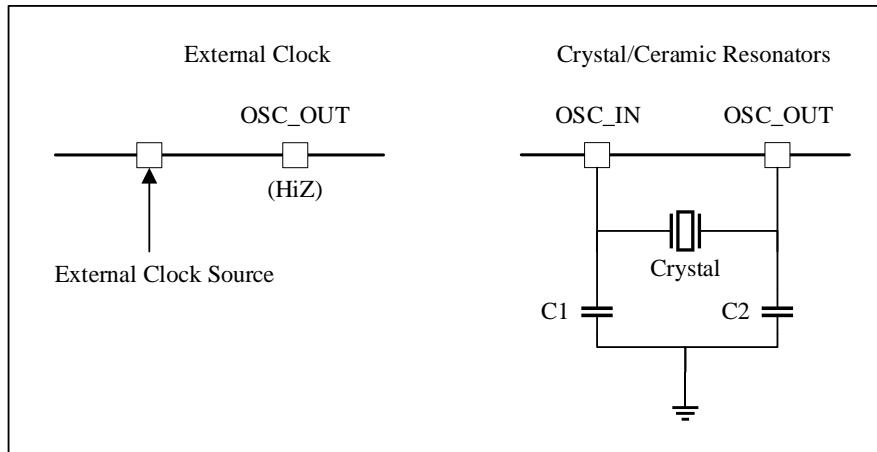

### 6.2.2.1 External clock source (HSE bypass)

In this mode, an external clock source must be provided. Its frequency can be up to 32MHz. Users can select this mode by setting the `RCC_CTRL.HSEBP` and `RCC_CTRL.HSEEN` bits. The external clock signal (50% duty cycle square, sine or triangle wave) must be connected to the `OSC_IN` pin while the `OSC_OUT` pin must be left floating (Hi-Z). See Figure 6-3.

### 6.2.2.2 External crystal/ceramic resonator (HSE crystal)

The 4 to 32 MHz external oscillator has the advantage of producing a more accurate master clock for the system. The associated hardware configuration is shown in See Figure 6-3. For more details, please refer to the electrical characteristics section of the datasheet.

The `RCC_CTRL.HSERDF` bit indicates whether the high-speed external oscillator is stable or not. At startup, the clock is not released until this bit is set by hardware. An interrupt can be generated if enabled in the Clock Interrupt Register (`RCC_CLKINT`).

HSE clock can be switched on and off by setting the `RCC_CTRL.HSEEN` bit.

## 6.2.3 HSI clock

The HSI (High Speed Internal) clock signal is generated by an internal 8MHz RC oscillator and can be used directly as system clock or as PLL input after dividing by 2. The HSI RC oscillator can provide a clock source without any external devices. It also has a shorter startup time than the HSE crystal oscillator. However, its frequency is less accurate even with calibration.

The HSI clock frequency of each chip has been calibrated to 1% (25°C) before leaving the factory. After the system reset, the factory calibration value is loaded into the `RCC_CTRL.HSICAL[7:0]` bits.

If the user application is subject to voltage or temperature variations, this may affect the accuracy of the RC oscillator. The HSI frequency can be trimmed by using the `RCC_CTRL.HSITRIM[4:0]` bits.

The `RCC_CTRL.HSIRDF` bit flag indicates if the HSI RC oscillator is stable. At startup, the HSI RC output clock is not released until this bit is set by hardware. HSI clock can be switched on and off using the `RCC_CTRL.HSIEN` bit. If the HSE crystal oscillator fails, the HSI clock is used as a backup clock source. Refer to Section 6.2.8 Clock Security System.

## 6.2.4 PLL clock

The internal PLL can be used to multiply the HSI or the HSE clock frequency. Refer to Figure 6-2 Clock Tree, The PLL configuration (selection of PLL input clock (HSI/HSE and divider) and multiplication factor) must be done before enabling PLL. Once the PLL is enabled, these parameters cannot be changed. The PLL can be configured using control bits in `RCC_CTRL` and `RCC_CFG` registers.

If the PLL interrupt is enabled in the clock interrupt register, an interrupt request can be generated when the PLL is ready.

If the USB interface needs to be used in the application, the PLL must be set to output 48, 72, 96, 144MHz clocks to provide the 48MHz USBCLK clock.

## 6.2.5 LSE clock

The LSE crystal is a 32.768KHz low speed external crystal or ceramic resonator. It provides a low-power and accurate clock source for the real-time clock or other timing functions.

The LSE clock is enabled and disabled by the `RCC_BDCTRL.LSEEN` bit.

The `RCC_BDCTRL.LSERD` bit indicates whether the LSE clock is stable. During the startup phase, the LSE clock signal is not released until this bit is set by hardware. If enabled in the clock interrupt register, an interrupt request can be generated.

### 6.2.5.1 LSE external clock source(LSE bypass)

In this mode, an external clock source with a frequency of up to 1 MHz can be provided. Users can select this mode by setting the `RCC_BDCTRL.LSEBP` and `RCC_BDCTRL.LSEEN` bits. The external clock signal (square, sine or triangle wave) with 50% duty cycle must be connected to the `OSC32_IN` pin while the `OSC32_OUT` pin must be left floating (Hi-Z).

## 6.2.6 LSI clock

The LSI RC can clock the IWDG and AWU in STOP0/STOP2 and STANDBY modes. The LSI clock frequency is about 40kHz. For further information please refer to the Electrical Characteristics section of the data sheet.

The LSI clock can be turned on or off using the `RCC_CTRLSTS.LSIEN` bit.

The `RCC_CTRLSTS.LSIRD` bit flag indicates if the LSI clock is stable. At startup, the clock is not released until this bit is set by hardware. An interrupt can be generated if enabled in the Clock Interrupt Register (`RCC_CLKINT`).

### 6.2.6.1 LSI calibration

The internal low-speed oscillator LSI can be calibrated to compensate for its frequency offset to obtain an RTC time base with acceptable accuracy, and an independent watchdog (IWDG) timeout (when these peripherals are clocked from the LSI).

Calibration can be achieved by measuring the LSI clock frequency using the TIM5's input clock (TIM5\_CLK). The measurement is guaranteed by the accuracy of the HSE. The software can obtain the accurate RTC clock base by adjusting the 20 bit prescaler of the RTC, and obtain the accurate independent watchdog (IWDG) timeout time by calculation.

The LSI calibration steps are as follows:

1. Turn on TIM5 and set channel 4 to input capture mode;
2. Set the AFIO\_RMP\_CFG.TIM5CH4\_RMP bit to 1, and connect the LSI to channel 4 of TIM5 internally;
3. Measure LSI clock frequency through TIM5 capture/compare 4 events or interrupts;
4. Set the 20 bit prescaler based on the measurement results and the desired RTC time base and independent watchdog timeout.

### 6.2.7 System clock (SYSCLK) selection

After a system reset, the HSI oscillator is selected as the system clock. It cannot be stopped when the clock source is used directly or indirectly through the PLL as the system clock.

Switching from one clock source to another will only occur when the target clock source is ready (either after a delay to start the stabilization phase or PLL stabilization). When the selected clock source is not ready, the switching of the system clock will not occur until the target clock source is ready.

Status bits in the clock control register (RCC\_CTRL) indicate which clock is ready and which clock is currently used as the system clock.

### 6.2.8 Clock security system (CLKSS)

Clock security system can be activated by software by setting the RCC\_CTRL.CLKSSSEN bit. Once activated, the clock detector is enabled after the startup delay of the HSE oscillator, and disabled when the HSE clock is turned off.

If the HSE clock fails, the HSE oscillator will be automatically turned off, and a clock failure event will be sent to the break input of the advanced timers (TIM1 and TIM8), and the Clock Security System Interrupt CLKSSIF will be generated, allowing the software to execute rescue operations. The CLKSSIF interrupt is connected to the NMI (Non-Maskable Interrupt) interrupt of the Cortex™-M4.

Once the CSS is activated and the HSE clock fails, the CSS interrupt is generated and the NMI is automatically generated. The NMI will be executed continuously until the CSS interrupt pending bit is cleared. Therefore, it is necessary to clear the CSS interrupt by setting the RCC\_CLKINT.CLKSSICLR bit in the NMI handler.

If the HSE oscillator is directly or indirectly used as the system clock (indirectly means: it is used as the PLL input clock, and the PLL clock is used as the system clock), the clock failure will cause a switch of the system clock to the HSI oscillator and the disabling of the external HSE oscillator. If HSE clock (divided or not) is selected as PLL input clock then upon HSE clock failure, the PLL will be turned off.

### 6.2.9 RTC clock

By programming RCC\_BDCTRL.RTCSEL[1:0] bits, the RTCCLK clock source can be either the HSE/128, LSE, or LSI clocks. This selection cannot be changed unless the backup domain is reset.

The LSE clock is in the backup domain, but the HSE and LSI clocks are not. therefore:

- If LSE is selected as RTC clock:
  - ◆ As long as VBAT remains powered, the RTC continues to work even though the VDD power supply is cut off.
- If LSI is selected as the automatic wake-up unit (AWU) clock:
  - ◆ If the VDD supply is cut off, the AWU status cannot be guaranteed. For LSI calibration, see Section 6.2.6 LSI Clock.
- If the HSE clock is divided by 128 as the RTC clock:
  - ◆ If the VDD power supply is cut off or the internal voltage regulator is turned off (the power supply in the 1.8V domain is cut off), the RTC state is indeterminate.
  - ◆ The PWR\_CTRL.DBKP bit of the power control register (see Section 4.4.2) must be set (to cancel the write protection of the backup power domain) to 1.

### 6.2.10 Watchdog clock

If the IWDG is started by either hardware option or software access, the LSI oscillator will be forced ON and cannot be disabled. After the LSI oscillator is stabilized, the clock is provided to the IWDG.

### 6.2.11 Clock output(MCO)

The microcontroller clock output (MCO) capability allows the clock signal to be output onto the external MCO pin.

The corresponding GPIO port register must be configured for the corresponding function. The following 4 clock signals can be selected as the MCO clock:

- SYSCLK
- HSI
- HSE
- PLL clock division

The clock selection is controlled by RCC\_CFG.MCO[2:0] bits.

## 6.3 RCC Registers

The RCC registers are accessible through AHB bus. The register description is as follows.

### 6.3.1 RCC register overview

Table 6-1 RCC register overview

| Offset | Register    | 31       | 30 | 29 | 28 | 27 | 26 | 25     | 24    | 23       | 22 | 21 | 20 | 19      | 18    | 17      | 16    | 15          | 14 | 13 | 12 | 11 | 10 | 9 | 8            | 7 | 6 | 5 | 4        | 3      | 2     | 1 | 0 |   |
|--------|-------------|----------|----|----|----|----|----|--------|-------|----------|----|----|----|---------|-------|---------|-------|-------------|----|----|----|----|----|---|--------------|---|---|---|----------|--------|-------|---|---|---|
| 000h   | RCC_CTRL    | Reserved |    |    |    |    |    | PLLRDF | PLLEN | Reserved |    |    |    | CLKSSEN | HSEBP | HSETRDF | HSEEN | HSICAL[7:0] |    |    |    |    |    |   | HSITRIM[4:0] |   |   |   | Reserved | HSIRDF | HSIEN |   |   |   |
|        | Reset Value |          |    |    |    |    |    | 0      | 0     |          |    |    |    | 0       | 0     | 0       | 0     | 0           | 0  | 0  | 0  | 0  | 0  | 0 | 0            | 0 | 1 | 0 | 0        | 0      | 0     | 0 | 1 | 1 |

| Offset | Register       | 31           | 30 | 29        | 28       | 27            | 26 | 25      | 24           | 23       | 22 | 21        | 20             | 19        | 18 | 17       | 16       | 15       | 14 | 13             | 12            | 11       | 10 | 9         | 8            | 7               | 6 | 5              | 4            | 3         | 2           | 1              | 0 |           |   |          |   |          |   |          |   |          |   |           |   |         |   |          |  |         |  |         |  |        |  |        |  |        |  |
|--------|----------------|--------------|----|-----------|----------|---------------|----|---------|--------------|----------|----|-----------|----------------|-----------|----|----------|----------|----------|----|----------------|---------------|----------|----|-----------|--------------|-----------------|---|----------------|--------------|-----------|-------------|----------------|---|-----------|---|----------|---|----------|---|----------|---|----------|---|-----------|---|---------|---|----------|--|---------|--|---------|--|--------|--|--------|--|--------|--|
| 004h   | RCC_CFG        | MCOPRES[3:0] |    |           | MCO[2:0] |               |    |         | USBPRES[1:0] |          |    |           | PLLMULFCT[3:0] |           |    |          | Reserved |          |    |                | APB2PRES[2:0] |          |    |           | AHBPRES[3:0] |                 |   |                | SCLKSTS[1:0] |           | SCLKSW[1:0] |                |   |           |   |          |   |          |   |          |   |          |   |           |   |         |   |          |  |         |  |         |  |        |  |        |  |        |  |
|        | Reset Value    | 0            | 0  | 1         | 0        | 0             | 0  | 0       | 0            | 0        | 0  | 0         | 0              | 0         | 0  | 0        | 0        | 0        | 0  | 0              | 0             | 0        | 0  | 0         | 0            | 0               | 0 | 0              | 0            | 0         | 0           | 0              | 0 | 0         |   |          |   |          |   |          |   |          |   |           |   |         |   |          |  |         |  |         |  |        |  |        |  |        |  |
| 008h   | RCC_CLKINT     | Reserved     |    |           |          |               |    |         |              |          |    | CLKSSICLR |                | Reserved  |    |          |          | Reserved |    |                |               | Reserved |    |           |              | PLLRDICLR       |   | HSERDICLR      |              | HSIRDICLR |             | LSERDICLR      |   | LSIRDICLR |   |          |   |          |   |          |   |          |   |           |   |         |   |          |  |         |  |         |  |        |  |        |  |        |  |
|        | Reset Value    | 0            |    |           |          |               |    |         |              |          |    | 0         | 0              |           |    |          | 0        |          |    |                | 0             |          |    |           | 0            | 0               |   | 0              |              | 0         |             | 0              |   | 0         |   |          |   |          |   |          |   |          |   |           |   |         |   |          |  |         |  |         |  |        |  |        |  |        |  |
| 00Ch   | RCC_APB2PRST   | Reserved     |    |           |          |               |    |         |              |          |    | I2C4RST   |                | I2C3RST   |    | UART7RST |          | UART6RST |    | DVPRST         |               | Reserved |    | USART1RST |              | TIM8RST         |   | SPI1RST        |              | TIM1RST   |             | Reserved       |   | IOPGRST   |   | IOPFRST  |   | IOPERST  |   | IOPDRST  |   | IOPCKRST |   | IOPBRST   |   | IOPARST |   | Reserved |  | AFIORST |  |         |  |        |  |        |  |        |  |
|        | Reset Value    | 0            |    |           |          |               |    |         |              |          |    | 0         | 0              |           | 0  |          | 0        |          | 0  |                | 0             |          | 0  |           | 0            |                 | 0 |                | 0            |           | 0           |                | 0 |           | 0 |          | 0 |          | 0 |          | 0 |          | 0 |           | 0 |         |   |          |  |         |  |         |  |        |  |        |  |        |  |
| 010h   | RCC_APB1PRST   | Reserved     |    | DACRST    |          | PWRST         |    | BKPRST  |              | CAN2RST  |    | CAN1RST   |                | Reserved  |    | USBRST   |          | I2C2RST  |    | I2C1RST        |               | UART5RST |    | UART4RST  |              | USART3RST       |   | USART2RST      |              | Reserved  |             | SPI3RST        |   | SPI2RST   |   | Reserved |   | WWDGRST  |   | Reserved |   | TIM7RST  |   | TIM6RST   |   | TIM5RST |   | TIM4RST  |  | TIM3RST |  | TIM2RST |  |        |  |        |  |        |  |
|        | Reset Value    | 0            |    | 0         |          | 0             |    | 0       |              | 0        |    | 0         |                | 0         |    | 0        |          | 0        |    | 0              |               | 0        |    | 0         |              | 0               |   | 0              |              | 0         |             | 0              |   | 0         |   | 0        |   | 0        |   | 0        |   | 0        |   | 0         |   | 0       |   | 0        |  |         |  |         |  |        |  |        |  |        |  |
| 014h   | RCC_AHBPCLKEN  | Reserved     |    |           |          |               |    |         |              |          |    | QSPIEN    |                | ETHMACEN  |    | ADC4EN   |          | ADC3EN   |    | ADC2EN         |               | ADC1EN   |    | SACEN     |              | SDIOEN          |   | RNGCEN         |              | Reserved  |             | CRCEEN         |   | Reserved  |   | FLITFEN  |   | Reserved |   | SRAMEN   |   | DMA2EN   |   | DMA1EN    |   |         |   |          |  |         |  |         |  |        |  |        |  |        |  |
|        | Reset Value    | 0            |    |           |          |               |    |         |              |          |    | 0         | 0              |           | 0  |          | 0        |          | 0  |                | 0             |          | 0  |           | 0            |                 | 0 |                | 0            |           | 0           |                | 0 |           | 0 |          | 0 |          | 0 |          | 0 |          | 0 |           | 0 |         | 0 |          |  |         |  |         |  |        |  |        |  |        |  |
| 018h   | RCC_APB2PCLKEN | Reserved     |    |           |          |               |    |         |              |          |    | I2C4EN    |                | I2C3EN    |    | UART7EN  |          | UART6EN  |    | DYPEN          |               | Reserved |    | USART1EN  |              | TIM8EN          |   | SPI1EN         |              | TIM1EN    |             | Reserved       |   | IOPGEN    |   | IOPPEN   |   | IOPDEN   |   | IOPEN    |   | IOPEN    |   | IOPEN     |   | IOPAEN  |   | Reserved |  | AFIOEN  |  |         |  |        |  |        |  |        |  |
|        | Reset Value    | 0            |    |           |          |               |    |         |              |          |    | 0         | 0              |           | 0  |          | 0        |          | 0  |                | 0             |          | 0  |           | 0            |                 | 0 |                | 0            |           | 0           |                | 0 |           | 0 |          | 0 |          | 0 |          | 0 |          | 0 |           | 0 |         | 0 |          |  |         |  |         |  |        |  |        |  |        |  |
| 01Ch   | RCC_APB1PCLKEN | OPAMPEN      |    | Reserved  |          | DACEN         |    | PWREN   |              | BKPEN    |    | CAN2EN    |                | CAN1EN    |    | Reserved |          | USBEN    |    | I2C2EN         |               | I2C1EN   |    | UART5EN   |              | UART4EN         |   | USART3EN       |              | USART2EN  |             | Reserved       |   | SPI3EN    |   | SPI2EN   |   | Reserved |   | WWDGEN   |   | Reserved |   | COMPFLTEN |   | COMPEN  |   | TIM7EN   |  | TIM6EN  |  | TIM5EN  |  | TIM4EN |  | TIM3EN |  | TIM2EN |  |
|        | Reset Value    | 0            |    | 0         |          | 0             |    | 0       |              | 0        |    | 0         |                | 0         |    | 0        |          | 0        |    | 0              |               | 0        |    | 0         |              | 0               |   | 0              |              | 0         |             | 0              |   | 0         |   | 0        |   | 0        |   | 0        |   | 0        |   | 0         |   | 0       |   | 0        |  | 0       |  | 0       |  |        |  |        |  |        |  |
| 020h   | RCC_BDCTRL     | Reserved     |    |           |          |               |    |         |              |          |    | BDSFTRST  |                | RTCEN     |    | Reserved |          |          |    |                |               |          |    |           |              | RTCSEL[1:0]     |   | Reserved       |              |           |             |                |   |           |   |          |   | LSEBPP   |   | LSERDIF  |   | LSEEN    |   |           |   |         |   |          |  |         |  |         |  |        |  |        |  |        |  |
|        | Reset Value    | 0            |    |           |          |               |    |         |              |          |    | 0         | 0              |           | 0  |          |          |          |    |                |               |          |    |           | 0            |                 | 0 |                |              |           |             |                |   |           |   |          | 0 |          | 0 |          | 0 |          |   |           |   |         |   |          |  |         |  |         |  |        |  |        |  |        |  |
| 024h   | RCC_CTRLSTS    | LPWRSTF      |    | WWDGRSTF  |          | IWDGRSTF      |    | SFTRSTF |              | PORRSTF  |    | PINRSTF   |                | MMURSTF   |    | RMRSTF   |          | RAMRSTF  |    | Reserved       |               | BKPEMCF  |    | RETEMCF   |              | BORRSTF         |   | Reserved       |              |           |             |                |   |           |   |          |   | LSIRD    |   | LSEEN    |   |          |   |           |   |         |   |          |  |         |  |         |  |        |  |        |  |        |  |
|        | Reset Value    | 0            |    | 0         |          | 0             |    | 0       |              | 1        |    | 1         |                | 0         |    | 0        |          | 0        |    | 0              |               | 0        |    | 0         |              | 0               |   | 0              |              |           |             |                |   |           |   |          |   | 1        |   | 1        |   |          |   |           |   |         |   |          |  |         |  |         |  |        |  |        |  |        |  |
| 028h   | RCC_AHBPRST    | Reserved     |    |           |          |               |    |         |              |          |    | QSPIRST   |                | ETHMACRST |    | ADC4RST  |          | ADC3RST  |    | ADC2RST        |               | ADC1RST  |    | SACRST    |              | Reserved        |   | RNGCRST        |              | Reserved  |             |                |   |           |   |          |   |          |   |          |   |          |   |           |   |         |   |          |  |         |  |         |  |        |  |        |  |        |  |
|        | Reset Value    | 0            |    |           |          |               |    |         |              |          |    | 0         | 0              |           | 0  |          | 0        |          | 0  |                | 0             |          | 0  |           | 0            |                 | 0 |                | 0            |           | 0           |                |   |           |   |          |   |          |   |          |   |          |   |           |   |         |   |          |  |         |  |         |  |        |  |        |  |        |  |
| 02Ch   | RCC_CFG2       | Reserved     |    | TIMCLKSEL |          | RNGCPRES[4:0] |    |         |              | Reserved |    |           |                |           |    |          |          |          |    | ADC1MPRES[4:0] |               |          |    | ADC1MSEL  |              | Reserved        |   | ADCPLLRES[4:0] |              |           |             | ADCHPRES [3:0] |   |           |   |          |   |          |   |          |   |          |   |           |   |         |   |          |  |         |  |         |  |        |  |        |  |        |  |
|        | Reset Value    | 0            |    | 0         |          | 0             |    |         |              | 0        |    |           |                |           |    |          |          |          |    | 0              |               |          |    | 0         |              | 0               |   | 0              |              |           |             | 0              |   |           |   |          |   |          |   |          |   |          |   |           |   |         |   |          |  |         |  |         |  |        |  |        |  |        |  |
| 030h   | RCC_CFG3       | Reserved     |    |           |          |               |    |         |              |          |    | TRNG1MEN  |                | TRNG1MSEL |    | Reserved |          |          |    |                |               |          |    |           |              | TRNG1MPRES[4:0] |   |                |              | Reserved  |             |                |   | BORRSTEN  |   | Reserved |   |          |   |          |   |          |   |           |   |         |   |          |  |         |  |         |  |        |  |        |  |        |  |
|        | Reset Value    | 0            |    |           |          |               |    |         |              |          |    | 0         |                | 0         |    | 0        |          |          |    |                |               |          |    |           |              | 0               |   |                |              | 0         |             |                |   | 1         |   | 0        |   |          |   |          |   |          |   |           |   |         |   |          |  |         |  |         |  |        |  |        |  |        |  |

### 6.3.2 Clock Control Register (RCC\_CTRL)

Address offset: 0x00

Reset value: 0x0000 0083

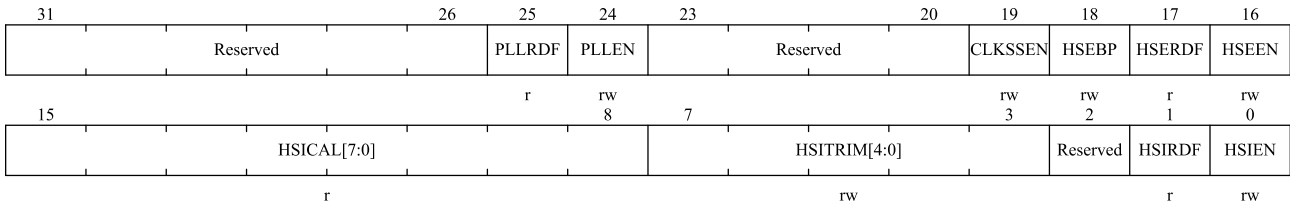

| Bit Field | Name        | Description  |
|-----------|-------------|--|
| 31:26     | Reserved    | Reserved, the reset value must be maintained.  |
| 25        | PLL RDF     | PLL clock ready flag<br>Set by hardware once PLL is ready.<br>0: PLL is not ready<br>1: PLL is ready   |
| 24        | PLLEN       | PLL enable<br>Set and cleared by software. When entering the stop0/stop2/standby mode, it is cleared by hardware. This bit cannot be cleared when PLL is used as the system clock.<br>When the HSI/HSE is used as the clock source for the PLL, the PLL will not be turned on until the HSI/HSE clock is ready.<br>0: Disable PLL<br>1: Enable PLL |
| 23:20     | Reserved    | Reserved, the reset value must be maintained.  |
| 19        | CLK SSEN    | Clock security system enable<br>Set and cleared by software.<br>0: Disable the clock detector<br>1: Enable the clock detector if the HSE oscillator is ready   |
| 18        | HSEBP       | External high-speed clock bypass enable<br>Set and cleared by software. This bit can only be written when the HSE oscillator is disabled.<br>0: Disable the bypass function of HSE oscillator<br>1: Enable the bypass function of HSE oscillator   |
| 17        | HSERDF      | External high-speed clock ready flag<br>Set by hardware once HSE is ready. This bit takes 6 HSE clock cycles to clear after the HSEEN bit is cleared.<br>0: HSE is not ready<br>1: HSE is ready  |
| 16        | HSEEN       | External high-speed clock enable<br>Set and cleared by software. When entering the stop0/stop2 or standby mode, it is cleared by hardware. This bit cannot be cleared when HSE is used directly or indirectly as the system clock.<br>0: Disable HSE oscillator<br>1: Enable HSE oscillator  |
| 15:8      | HSICAL[7:0] | Internal high-speed clock calibration value  |

| Bit Field | Name         | Description   |
|-----------|--------------|---|
|           |              | These bits are automatically initialized at startup.  |
| 7:3       | HSITRIM[4:0] | Internal high-speed clock correction value<br>Written by software. The values of these bits will be added to the HSICAL[7:0] bits in order to form the final value for calibrating the frequency of the internal HSI RC oscillator. The trimming step is around 40 kHz between two consecutive HSICAL steps, and the default value is 16, which can adjust the HSI to 8 MHz $\pm 1\%$ .             |
| 2         | Reserved     | Reserved, the reset value must be maintained.   |
| 1         | HSIRDF       | Internal high-speed clock ready flag<br>Set by hardware once HSI is stable. After the HSIEN bit is cleared, it takes 6 internal 8 MHz oscillator clock cycles to go low.<br>0: HSI is not ready<br>1: HSI is ready  |
| 0         | HSIEN        | Internal high-speed clock enable<br>Set and cleared by software. This bit cannot be cleared when HSI is used as the system clock. When returning from stop0/stop2 or standby mode or HSE failure occurs, set by hardware to enable the HSI oscillator. This bit cannot be reset if the HSI is used directly or indirectly as system clock.<br>0: Disable HSI oscillator<br>1: Enable HSI oscillator |

### 6.3.3 Clock Configuration Register (RCC\_CFG)

Address offset: 0x04

Reset value: 0x2000 0000

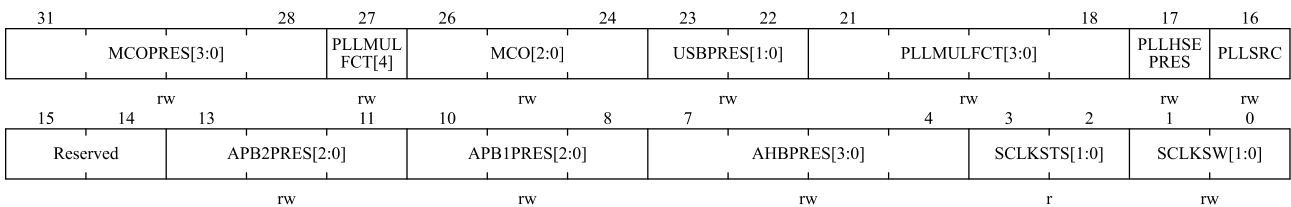

| Bit Field | Name         | Description  |
|-----------|--------------|--|
| 31:28     | MCOPRES[3:0] | MCO prescaler<br>Set and cleared by software.<br>0010: Divide PLL clock by 2 as MCO clock<br>0011: Divide PLL clock by 3 as MCO clock<br>0100: Divide PLL clock by 4 as MCO clock<br>0101: PLL clock divided by 5 as MCO clock<br>0110: Divide PLL clock by 6 as MCO clock<br>0111: Divide PLL clock by 7 as MCO clock<br>1000: Divide PLL clock by 8 as MCO clock<br>1001: PLL clock divided by 9 as MCO clock<br>1010: Divide PLL clock by 10 as MCO clock |

| Bit Field | Name           | Description  |
|-----------|----------------|--|
|           |                | 1011: Divide PLL clock by 11 as MCO clock<br>1100: PLL clock divided by 12 as MCO clock<br>1101: Divide PLL clock by 13 as MCO clock<br>1110: Divide PLL clock by 14 as MCO clock<br>1111: Divide PLL clock by 15 as MCO clock<br>Other values: not allowed to set   |
| 27        | PLLMULFCT[4]   | This bit is combined with bit[21:18] to form a PLL multiplication factor. Please refer to PLLMULFCT[3:0].  |
| 26:24     | MCO[2:0]       | Microcontroller clock output selection<br>Set and cleared by software.<br>0xx: no clock output<br>100: Select system clock (SYSCLK) output<br>101: select internal high-speed clock (HSI) output<br>110: select external high-speed clock (HSE) output<br>111: Select the output after PLL frequency division<br><i>Notice: This clock output may be truncated when starting and switching the MCO clock source.</i><br><i>When the system clock is output to the MCO pin, the output clock frequency should not exceed 50MHz (the highest frequency of the I/O port).</i>   |
| 23:22     | USBPRES[1:0]   | USB prescaler.<br>Set or cleared by software to generate a 48MHz USB clock. The values of these bits must be valid before enabling the USB clock in the RCC_APB1PCKEN register.<br>00: Divide the PLL clock by 1.5 as the USB clock<br>01: The PLL clock is directly used as the USB clock<br>10: Divide the PLL clock by 2 as the USB clock<br>11: Divide the PLL clock by 3 as the USB clock   |
| 21:18     | PLLMULFCT[3:0] | PLL multiplication factor (including bit 27)<br>Written by software to define PLL multiplication factor. These bits can only be written when the PLL is disabled. The PLL output frequency must not exceed 144MHz.<br>00000: PLL input clock $\times 2$<br>00001: PLL input clock $\times 3$<br>00010: PLL input clock $\times 4$<br>00011: PLL input clock $\times 5$<br>00100: PLL input clock $\times 6$<br>00101: PLL input clock $\times 7$<br>00110: PLL input clock $\times 8$<br>00111: PLL input clock $\times 9$<br>01000: PLL input clock $\times 10$<br>01001: PLL input clock $\times 11$<br>01010: PLL input clock $\times 12$<br>01011: PLL input clock $\times 13$ |

| Bit Field | Name          | Description  |
|-----------|---------------|--|
|           |               | 01100: PLL input clock $\times$ 14<br>01101: PLL input clock $\times$ 15<br>01110: PLL input clock $\times$ 16<br>01111: PLL input clock $\times$ 16<br>10000: PLL input clock $\times$ 17<br>10001: PLL input clock $\times$ 18<br>10010: PLL input clock $\times$ 19<br>10011: PLL input clock $\times$ 20<br>10100: PLL input clock $\times$ 21<br>10101: PLL input clock $\times$ 22<br>10110: PLL input clock $\times$ 23<br>10111: PLL input clock $\times$ 24<br>11000: PLL input clock $\times$ 25<br>11001: PLL input clock $\times$ 26<br>11010: PLL input clock $\times$ 27<br>11011: PLL input clock $\times$ 28<br>11100: PLL input clock $\times$ 29<br>11101: PLL input clock $\times$ 30<br>11110: PLL input clock $\times$ 31<br>11111: PLL input clock $\times$ 32 |
| 17        | PLLHSEPRES    | HSE prescaler for PLL input<br>Set and cleared by software to divide HSE before PLL entry. This bit can only be written when PLL is disabled.<br>0: HSE clock not divided<br>1: HSE divided by 2   |
| 16        | PLLSRC        | PLL clock source<br>Set and cleared by software to select PLL clock source. This bit can only be written when PLL is disabled.<br>0: HSI clock divided by 2 is used as the PLL input clock<br>1: HSE clock selected as PLL input clock   |
| 15:14     | Reserved      | Reserved, the reset value must be maintained.  |
| 13:11     | APB2PRES[2:0] | APB high-speed (APB2) prescaler<br>Set and cleared by software to configure the division factor of APB2 clock (PCLK2). Make sure that PCLK2 does not exceed 72MHz.<br>0xx: HCLK not divided<br>100: HCLK divided by 2<br>101: HCLK divided by 4<br>110: HCLK divided by 8<br>111: HCLK divided by 16   |
| 10:8      | APB1PRES[2:0] | APB low-speed (APB1) prescaler<br>Set and cleared by software to configure the division factor of APB1 clock (PCLK1). Make sure that PCLK1 does not exceed 36MHz.<br>0xx: HCLK not divided   |

| Bit Field | Name         | Description  |
|-----------|--------------|--|
|           |              | 100: HCLK divided by 2<br>101: HCLK divided by 4<br>110: HCLK divided by 8<br>111: HCLK divided by 16  |
| 7:4       | AHBPRES[3:0] | AHB prescaler<br>Set and cleared by software to configure the division factor of the AHB clock (HCLK).<br>0xxx: SYSCLK not divided<br>1000: SYSCLK divided by 2<br>1001: SYSCLK divided by 4<br>1010: SYSCLK divided by 8<br>1011: SYSCLK divided by 16<br>1100: SYSCLK divided by 64<br>1101: SYSCLK divided by 128<br>1110: SYSCLK divided by 256<br>1111: SYSCLK divided by 512 |
| 3:2       | SCLKSTS[1:0] | System clock switching status<br>Set and cleared by hardware to indicate which clock source is used as system clock<br>00: The system clock comes from HSI<br>01: The system clock comes from HSE<br>10: The system clock comes from the PLL output<br>11: Unavailable   |
| 1:0       | SCLKSW[1:0]  | System clock switch<br>Set and cleared by software to select the system clock source.<br>Set by hardware to force HSI selection when exiting from the stop2 or standby mode, or when the HSE oscillator fails (RCC_CTRL.CLKSSEN is enabled).<br>00: Select HSI as system clock<br>01: Select HSE as system clock<br>10: Select PLL output as system clock<br>11: Unavailable       |

### 6.3.4 Clock Interrupt Register (RCC\_CLKINT)

Address offset: 0x08

Reset value: 0x0000 0000

|          |  |  |  |              |              |              |              |               |          |          |               |               |               |               |               |         |        |        |
|----------|--|--|--|--------------|--------------|--------------|--------------|---------------|----------|----------|---------------|---------------|---------------|---------------|---------------|---------|--------|--------|
| 31       |  |  |  | 24           |              |              |              | 23            | 22       | 21       | 20            | 19            | 18            | 17            | 16            |         |        |        |
| Reserved |  |  |  |              |              |              |              | CLKSSI<br>CLR | Reserved |          | PLLRDI<br>CLR | HSERDI<br>CLR | HSIRDI<br>CLR | LSERDI<br>CLR | LSIRDI<br>CLR |         |        |        |
| 15       |  |  |  | 13           |              | 12           | 11           | 10            | 9        | 8        | w<br>7        | 6             | 5             | w<br>4        | w<br>3        | w<br>2  | w<br>1 | w<br>0 |
| Reserved |  |  |  | PLLRDI<br>EN | HSERDI<br>EN | HSIRDI<br>EN | LSERDI<br>EN | LSIRDI<br>EN  | CLKSSIF  | Reserved |               | PLLRDIF       | HSERDIF       | HSIRDIF       | LSERDIF       | LSIRDIF |        |        |
|          |  |  |  | rw           | rw           | rw           | rw           | rw            | r        |          |               | r             | r             | r             | r             | r       |        |        |

| Bit Field | Name      | Description   |
|-----------|-----------|---|
| 31:24     | Reserved  | Reserved, the reset value must be maintained.   |
| 23        | CLKSSICLR | Clock security system interrupt clear<br>Set by the software to clear the CLKSSIF flag.<br>0: No effect<br>1: Clear the CLKSSIF flag                                    |
| 22:21     | Reserved  | Reserved, the reset value must be maintained.   |
| 20        | PLLRDICLR | PLL ready interrupt clear<br>Set by the software to clear the PLLRDIF flag.<br>0: No effect<br>1: Clear the PLLRDIF flag  |
| 19        | HSERDICLR | HSE ready interrupt clear<br>Set by the software to clear the HSERDIF flag.<br>0: Not used<br>1: Clear HSERDIF flag   |
| 18        | HSIRDICLR | HSI ready interrupt clear<br>Set by the software to clear the HSIRDIF flag.<br>0: Not used<br>1: Clear the HSIRDIF flag   |
| 17        | LSERDICLR | LSE ready interrupt clear<br>Set by the software to clear the LSERDIF flag.<br>0: Not used<br>1: Clear LSERDIF flag   |
| 16        | LSIRDICLR | LSI ready interrupt clear<br>Set by software to clear the LSIRDIF flag.<br>0: Not used<br>1: Clear the LSIRDIF flag   |
| 15:13     | Reserved  | Reserved, the reset value must be maintained.   |
| 12        | PLLRDIEN  | PLL ready interrupt enable<br>Set and cleared by software to enable and disable PLL ready interrupt<br>0: Disable PLL ready interrupt<br>1: Enable PLL ready interrupt  |
| 11        | HSERDIEN  | HSE ready interrupt enable<br>Set and cleared by software to enable and disable HSE ready interrupt.<br>0: Disable HSE ready interrupt<br>1: Enable HSE Ready Interrupt |
| 10        | HSIRDIEN  | HSI ready interrupt enable<br>Set and cleared by software to enable and disable HSI ready interrupt.<br>0: Disable HSI ready interrupt<br>1: Enable HSI ready interrupt |
| 9         | LSERDIEN  | LSE ready interrupt enable<br>Set and cleared by software to enable and disable LSE ready interrupt.<br>0: Disable LSE ready interrupt<br>1: Enable LSE ready interrupt |

| Bit Field | Name     | Description  |
|-----------|----------|--|
| 8         | LSIRDIEN | LSI ready interrupt enable<br>Set and cleared by software to enable and disable LSI ready interrupt.<br>0: Disable LSI ready interrupt<br>1: Enable LSI ready interrupt  |
| 7         | CLKSSIF  | Clock security system interrupt flag<br>Set by hardware when a failure is detected in the external HSE oscillator.<br>0: No clock security system interrupt caused by HSE clock failure<br>1: Clock security system interrupt caused by HSE clock failure                      |
| 6:5       | Reserved | Reserved, the reset value must be maintained.  |
| 4         | PLLRDIF  | PLL ready interrupt flag<br>This bit is set by hardware when PLLRDIEN is set and PLL clock is ready.<br>This bit is cleared by software by setting the PLLRDICLR bit.<br>0: No clock ready interrupt caused by PLL lock<br>1: Clock ready interrupt caused by PLL lock         |
| 3         | HSERDIF  | HSE ready interrupt flag<br>Set by hardware when HSERDIEN is set and the HSE clock is ready.<br>This bit is cleared by software by setting the HSERDICLR bit.<br>0: No clock ready interrupt caused by HSE oscillator<br>1: Clock ready interrupt caused by HSE oscillator     |
| 2         | HSIRDIF  | HSI ready interrupt flag<br>Set by hardware when HSIRDIEN is set and the HSI clock is ready.<br>This bit is cleared by software by setting the HSERDICLR bit.<br>0: No clock ready interrupt caused by HSI oscillator<br>1: Clock ready interrupt caused by HSI oscillator     |
| 1         | LSERDIF  | LSE ready interrupt flag<br>Set by hardware when LSERDIEN is set and the LSE clock is ready.<br>This bit is cleared by the software by setting the LSERDICLR bit.<br>0: No clock ready interrupt caused by LSE oscillator<br>1: Clock ready interrupt caused by LSE oscillator |
| 0         | LSIRDIF  | LSI ready interrupt flag<br>Set by the hardware when LSIRDIEN is set and the LSI clock is ready.<br>This bit is cleared by software by setting the LSIRDICLR bit.<br>0: No clock ready interrupt caused by LSI oscillator<br>1: Clock ready interrupt caused by LSI oscillator |

### 6.3.5 APB2 Peripheral Reset Register (RCC\_APB2PRST)

Address offset: 0x0c

Reset value: 0x0000 0000

|          |           |         |         |         |          |   |         |         |         |          |         |         |         |          |    |          |         |          |          |         |         |          |          |        |    |    |
|----------|-----------|---------|---------|---------|----------|---|---------|---------|---------|----------|---------|---------|---------|----------|----|----------|---------|----------|----------|---------|---------|----------|----------|--------|----|----|
| 31       |           |         |         |         |          |   |         |         |         | 21       |         |         |         |          |    |          |         |          |          | 20      | 19      | 18       | 17       | 16     |    |    |
| Reserved |           |         |         |         |          |   |         |         |         | Reserved |         |         |         |          |    |          |         |          |          | I2C4RST | I2C3RST | UART7RST | UART6RST | DVPRST |    |    |
|          |           |         |         |         |          |   |         |         |         |          |         |         |         |          | rw | rw       | rw      | rw       | rw       | rw      | rw      | rw       | rw       | rw     | rw | rw |
| 15       | 14        | 13      | 12      | 11      | 10       | 9 | 8       | 7       | 6       | 5        | 4       | 3       | 2       | 1        | 0  | Reserved | AFIORST | Reserved | Reserved |         |         |          |          |        |    |    |
| Reserved | USART1RST | TIM8RST | SPI1RST | TIM1RST | Reserved |   | IOPGRST | IOPFRST | IOPERST | IOPDRST  | IOPCRST | IOPBRST | IOPARST | Reserved |    | AFIORST  |         |          |          |         |         |          |          |        |    |    |
| rw       | rw        | rw      | rw      | rw      |          |   | rw      | rw      | rw      | rw       | rw      | rw      | rw      | rw       | rw | rw       | rw      | rw       | rw       |         |         |          |          |        |    |    |

| Bit Field | Name      | Description   |
|-----------|-----------|---|
| 31:21     | Reserved  | Reserved, the reset value must be maintained.   |
| 20        | I2C4RST   | I2C4 reset<br>Set and cleared by software.<br>0: Clear the reset<br>1: Reset I2C4             |
| 19        | I2C3RST   | I2C3 reset<br>Set and cleared by software.<br>0: Clear the reset<br>1: Reset I2C3             |
| 18        | UART7RST  | UART7 reset<br>Set and cleared by software.<br>0: Clear the reset<br>1: Reset UART7           |
| 17        | UART6RST  | UART6 reset<br>Set and cleared by software.<br>0: Clear the reset<br>1: Reset UART6           |
| 16        | DVPRST    | DVP reset<br>Set and cleared by software.<br>0: Clear the reset<br>1: Reset DVP               |
| 15        | Reserved  | Reserved, the reset value must be maintained.   |
| 14        | USART1RST | USART1 reset<br>Set and cleared by software.<br>0: Clear the reset<br>1: Reset USART1         |
| 13        | TIM8RST   | TIM8 timer reset<br>Set and cleared by software.<br>0: Clear the reset<br>1: Reset TIM8 timer |
| 12        | SPI1RST   | SPI1 reset<br>Set and cleared by software.<br>0: Clear the reset<br>1: Reset SPI1             |
| 11        | TIM1RST   | TIM1 timer reset<br>Set and cleared by software.  |

| Bit Field | Name     | Description  |
|-----------|----------|--|
|           |          | 0: Clear the reset<br>1: Reset TIM1 timer  |
| 10:9      | Reserved | Reserved, the reset value must be maintained.  |
| 8         | IOPGRST  | GPIO port G reset.<br>Set or cleared by software.<br>0: Clear the reset<br>1: Reset GPIO port G                  |
| 7         | IOPFRST  | GPIO port F reset.<br>Set or cleared by software.<br>0: Clear the reset<br>1: Reset GPIO port F                  |
| 6         | IOPERST  | GPIO port E reset.<br>Set or cleared by software.<br>0: Clear the reset<br>1: Reset GPIO port E                  |
| 5         | IOPDRST  | GPIO port D reset.<br>Set or cleared by software.<br>0: Clear the reset<br>1: Reset GPIO port D                  |
| 4         | IOPCRST  | GPIO port C reset.<br>Set or cleared by software.<br>0: Clear the reset<br>1: Reset GPIO port C                  |
| 3         | IOPBRST  | GPIO port B reset.<br>Set or cleared by software.<br>0: Clear the reset<br>1: Reset GPIO port B                  |
| 2         | IOPARST  | GPIO port A reset.<br>Set or cleared by software.<br>0: Clear the reset<br>1: Reset GPIO port A                  |
| 1         | Reserved | Reserved, the reset value must be maintained.  |
| 0         | AFIORST  | Alternate function IO reset<br>Set and cleared by software.<br>0: Clear the reset<br>1: Reset Alternate Function |

### 6.3.6 APB1 Peripheral Reset Register (RCC\_APB1PRST)

Address offset: 0x10

Reset value: 0x0000 0000

|          |         |          |        |         |         |         |          |        |         |         |          |          |           |           |          |    |
|----------|---------|----------|--------|---------|---------|---------|----------|--------|---------|---------|----------|----------|-----------|-----------|----------|----|
| 31       | 30      | 29       | 28     | 27      | 26      | 25      | 24       | 23     | 22      | 21      | 20       | 19       | 18        | 17        | 16       |    |
| Reserved |         | DACRST   | PWRRST | BKPRST  | CAN2RST | CAN1RST | Reserved | USBRST | I2C2RST | I2C1RST | UART5RST | UART4RST | USART3RST | USART2RST | Reserved |    |
|          |         | rw       | rw     | rw      | rw      | rw      |          | rw     | rw      | rw      | rw       | rw       | rw        | rw        |          |    |
| 15       | 14      | 13       | 12     | 11      | 10      |         |          |        |         | 6       | 5        | 4        | 3         | 2         | 1        | 0  |
| SPI3RST  | SPI2RST | Reserved |        | WWDGRST |         |         | Reserved |        |         | TIM7RST | TIM6RST  | TIM5RST  | TIM4RST   | TIM3RST   | TIM2RST  |    |
| rw       | rw      |          |        | rw      |         |         |          |        |         | rw      | rw       | rw       | rw        | rw        | rw       | rw |

| Bit Field | Name     | Description   |
|-----------|----------|---|
| 31:30     | Reserved | Reserved, the reset value must be maintained.   |
| 29        | DACRST   | DAC interface reset.<br>Set or cleared by software.<br>0: Clear the reset<br>1: Reset the DAC interface       |
| 28        | PWRRST   | Power interface reset<br>Set and cleared by software.<br>0: Clear the reset<br>1: Reset the power interface   |
| 27        | BKPRST   | Backup interface reset.<br>Set or cleared by software.<br>0: Clear the reset<br>1: Reset the Backup interface |
| 26        | CAN2RST  | CAN2 reset<br>Set or cleared by software.<br>0: Clear the reset<br>1: Reset CAN2                              |
| 25        | CAN1RST  | CAN1 reset<br>Set or cleared by software.<br>0: Clear the reset<br>1: Reset CAN1                              |
| 24        | Reserved | Reserved, the reset value must be maintained.   |
| 23        | USBRST   | USB reset.<br>Set or cleared by software.<br>0: clear the reset<br>1: Reset USB                               |
| 22        | I2C2RST  | I2C2 reset<br>Set and cleared by software.<br>0: Clear the reset<br>1: Reset I2C2                             |
| 21        | I2C1RST  | I2C1 reset<br>Set and cleared by software.<br>0: Clear the reset<br>1: Reset I2C1                             |
| 20        | UART5RST | UART5 reset.<br>Set or cleared by software.   |

| Bit Field | Name      | Description   |
|-----------|-----------|---|
|           |           | 0: clear the reset<br>1: Reset UART5  |
| 19        | UART4RST  | UART4 reset<br>Set and cleared by software.<br>0: Clear the reset<br>1: Reset UART4                     |
| 18        | USART3RST | USART3 reset.<br>Set or cleared by software.<br>0: clear the reset<br>1: Reset USART3                   |
| 17        | USART2RST | USART2 reset<br>Set and cleared by software.<br>0: Clear the reset<br>1: Reset USART2                   |
| 16        | Reserved  | Reserved, the reset value must be maintained.   |
| 15        | SPI3RST   | SPI3 reset.<br>Set or cleared by software.<br>0: clear the reset<br>1: Reset SPI3                       |
| 14        | SPI2RST   | SPI2 reset.<br>Set or cleared by software.<br>0: clear the reset<br>1: Reset SPI2                       |
| 13:12     | Reserved  | Reserved, the reset value must be maintained.   |
| 11        | WWDGRST   | Window watchdog reset<br>Set and cleared by software.<br>0: Clear the reset<br>1: Reset window watchdog |
| 10:6      | Reserved  | Reserved, the reset value must be maintained.   |
| 5         | TIM7RST   | TIM7 timer reset.<br>Set or cleared by software.<br>0: clear the reset<br>1: Reset the TIM7 timer       |
| 4         | TIM6RST   | TIM6 timer reset<br>Set and cleared by software.<br>0: Clear the reset<br>1: Reset TIM6 timer           |
| 3         | TIM5RST   | TIM5 timer reset<br>Set and cleared by software.<br>0: Clear the reset<br>1: Reset TIM5 timer           |
| 2         | TIM4RST   | TIM4 timer reset<br>Set and cleared by software.  |

| Bit Field | Name    | Description   |
|-----------|---------|---|
|           |         | 0: Clear the reset<br>1: Reset TIM4 timer   |
| 1         | TIM3RST | TIM3 timer reset<br>Set and cleared by software.<br>0: Clear the reset<br>1: Reset TIM3 timer |
| 0         | TIM2RST | TIM2 timer reset<br>Set and cleared by software.<br>0: Clear the reset<br>1: Reset TIM2 timer |

### 6.3.7 AHB Peripheral Clock Enable Register (RCC\_AHBPCLEN)

Address offset: 0x14

Reset value: 0x0000 0014

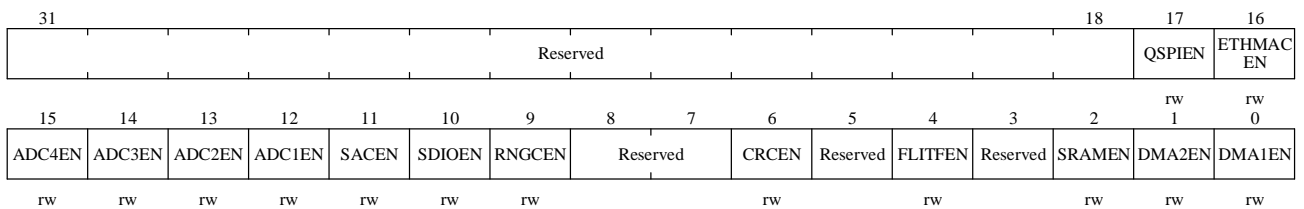

| Bit Field | Name     | Description  |
|-----------|----------|--|
| 31:18     | Reserved | Reserved, the reset value must be maintained.  |
| 17        | QSPIEN   | QSPI clock enable<br>Set and cleared by software.<br>0: QSPI clock disabled<br>1: QSPI clock enabled       |
| 16        | ETHMACEN | ETHMAC clock enable<br>Set and cleared by software.<br>0: ETHMAC clock disabled<br>1: ETHMAC clock enabled |
| 15        | ADC4EN   | ADC4 clock enable<br>Set and cleared by software.<br>0: ADC4 clock disabled<br>1: ADC4 clock enabled       |
| 14        | ADC3EN   | ADC3 clock enable<br>Set and cleared by software.<br>0: ADC3 clock disabled<br>1: ADC3 clock enabled       |
| 13        | ADC2EN   | ADC2 clock enable<br>Set and cleared by software.<br>0: ADC2 clock disabled                                |

| Bit Field | Name     | Description  |
|-----------|----------|--|
|           |          | 1: ADC2 clock enabled  |
| 12        | ADC1EN   | ADC1 clock enable<br>Set and cleared by software.<br>0: ADC1 clock disabled<br>1: ADC1 clock enabled   |
| 11        | SACEN    | SAC clock enable<br>Set and cleared by software.<br>0: SAC clock disabled<br>1: SAC clock enabled  |
| 10        | SDIOEN   | SAC clock enable<br>Set and cleared by software.<br>0: SAC clock disabled<br>1: SAC clock enabled  |
| 9         | RNGCEN   | RNGC clock enable<br>Set and cleared by software.<br>0: RNGC clock disabled<br>1: RNGC clock enabled   |
| 8:7       | Reserved | Reserved, the reset value must be maintained.  |
| 6         | CRCEN    | CRC clock enable<br>Set and cleared by software.<br>0: CRC clock disabled<br>1: CRC clock enabled  |
| 5         | Reserved | Reserved, the reset value must be maintained.  |
| 4         | FLITFEN  | Flash interface circuit clock enable.<br>Set or cleared by software.<br>0: Disable the clock of the flash interface circuit<br>1: Enable the clock of the flash interface circuit  |
| 3         | Reserved | Reserved   |
| 2         | SRAMEN   | SRAM interface clock enable<br>Set and cleared by software to disable/enable SRAM interface clock during Sleep mode.<br>0: SRAM interface clock disabled during Sleep mode.<br>1: SRAM interface clock enabled during Sleep mode |
| 0         | DMA2EN   | DMA2 clock enable<br>Set and cleared by software.<br>0: DMA2 clock disabled<br>1: DMA2 clock enabled   |
| 0         | DMA1EN   | DMA1 clock enable<br>Set and cleared by software.<br>0: DMA1 clock disabled<br>1: DMA1 clock enabled   |

### 6.3.8 APB2 Peripheral Clock Enable Register (RCC\_APB2PCLKEN)

Address offset: 0x18

Reset value: 0x0000 0000

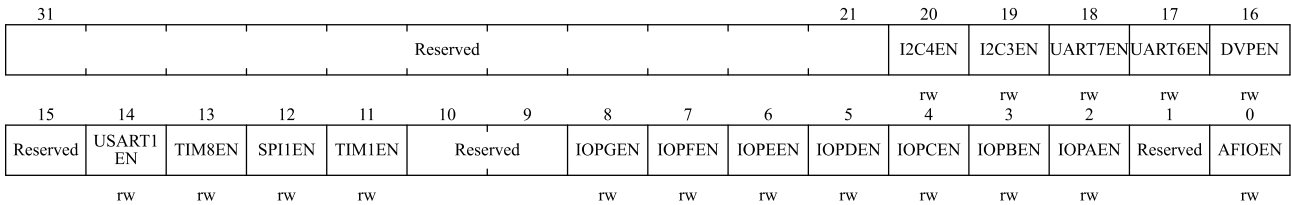

| Bit Field | Name     | Description  |
|-----------|----------|--|
| 31:21     | Reserved | Reserved, the reset value must be maintained.  |
| 20        | I2C4EN   | I2C4 clock enable<br>Set and cleared by software.<br>0: I2C4 clock disabled<br>1: I2C4 clock enabled                   |
| 19        | I2C3EN   | I2C3 clock enable<br>Set and cleared by software.<br>0: I2C3 clock disabled<br>1: I2C3 clock enabled                   |
| 18        | UART7EN  | UART7 clock enable<br>Set and cleared by software.<br>0: UART7 clock disabled<br>1: UART7 clock enabled                |
| 17        | UART6EN  | UART6 clock enable<br>Set and cleared by software.<br>0: UART6 clock disabled<br>1: UART6 clock enabled                |
| 16        | DVPEN    | DVP clock enable<br>Set and cleared by software.<br>0: DVP clock disabled<br>1: DVP clock enabled                      |
| 15        | Reserved | Reserved, the reset value must be maintained.  |
| 14        | USART1EN | USART1 clock enable<br>Set and cleared by software.<br>0: USART1 clock disabled<br>1: USART1 clock enabled             |
| 13        | TIM8EN   | TIM8 Timer clock enable<br>Set and cleared by software.<br>0: TIM8 timer clock disabled<br>1: TIM8 timer clock enabled |

| Bit Field | Name     | Description   |
|-----------|----------|---|
| 12        | SPI1EN   | SPI1 clock enable<br>Set and cleared by software.<br>0: SPI1 clock disabled<br>1: SPI1 clock enabled  |
| 11        | TIM1EN   | TIM1 timer clock enable<br>Set and cleared by software.<br>0: TIM1 timer clock disabled<br>1: TIM1 timer clock enabled                                  |
| 10:9      | Reserved | Reserved, the reset value must be maintained.   |
| 8         | IOPGEN   | IO Port G clock enable<br>Set and cleared by software.<br>0: IO Port G clock disabled<br>1: IO Port G clock enabled                                     |
| 7         | IOPFEN   | IO Port F clock enable<br>Set and cleared by software.<br>0: IO Port F clock disabled<br>1: IO Port F clock enabled                                     |
| 6         | IOPEEN   | IO Port E clock enable<br>Set and cleared by software.<br>0: IO Port E clock disabled<br>1: IO Port E clock enabled                                     |
| 5         | IOPDEN   | IO Port D clock enable<br>Set and cleared by software.<br>0: IO Port D clock disabled<br>1: IO Port D clock enabled                                     |
| 4         | IOPCEN   | IO Port C clock enable<br>Set and cleared by software.<br>0: IO Port C clock disabled<br>1: IO Port C clock enabled                                     |
| 3         | IOPBEN   | IO Port B clock enable<br>Set and cleared by software.<br>0: IO Port B clock disabled<br>1: IO Port B clock enabled                                     |
| 2         | IOPAEN   | IO Port A clock enable<br>Set and cleared by software.<br>0: IO Port A clock disabled<br>1: IO Port A clock enabled                                     |
| 1         | Reserved | Reserved, the reset value must be maintained.   |
| 0         | AFIOEN   | Alternate function IO clock enable<br>Set and cleared by software.<br>0: Alternate Function IO clock disabled<br>1: Alternate Function IO clock enabled |

### 6.3.9 APB1 Peripheral Clock Enable Register (RCC\_APB1PCLKEN)

Address offset: 0x1c

Reset value: 0x0000 0000

|             |          |          |       |            |        |          |          |                |        |        |         |         |              |              |          |
|-------------|----------|----------|-------|------------|--------|----------|----------|----------------|--------|--------|---------|---------|--------------|--------------|----------|
| 31          | 30       | 29       | 28    | 27         | 26     | 25       | 24       | 23             | 22     | 21     | 20      | 19      | 18           | 17           | 16       |
| OPAMP<br>EN | Reserved | DACEN    | PWREN | BKPEN      | CAN2EN | CAN1EN   | Reserved | USBEN          | I2C2EN | I2C1EN | UART5EN | UART4EN | USART3<br>EN | USART2<br>EN | Reserved |
| rw          |          | rw       | rw    | rw         | rw     | rw       |          | rw             | rw     | rw     | rw      | rw      | rw           | rw           |          |
| 15          | 14       | 13       | 12    | 11         | 10     | 9        | 8        | 7              | 6      | 5      | 4       | 3       | 2            | 1            | 0        |
| SPI3EN      | SPI2EN   | Reserved |       | WWDG<br>EN | TSCEN  | Reserved |          | COMP<br>FILTEN | COMPEN | TIM7EN | TIM6EN  | TIM5EN  | TIM4EN       | TIM3EN       | TIM2EN   |
| rw          | rw       |          |       | rw         | rw     |          |          | rw             | rw     | rw     | rw      | rw      | rw           | rw           | rw       |

| Bit Field | Name     | Description  |
|-----------|----------|--|
| 31        | OPAMPEN  | OPAMP clock enable.<br>Set or cleared by software.<br>0: Disable OPAMP clock<br>1: Enable OPAMP clock                                    |
| 30        | Reserved | Reserved, the reset value must be maintained.  |
| 29        | DACEN    | DAC interface clock enable<br>Set and cleared by software.<br>0: DAC interface clock disabled<br>1: DAC interface clock enable           |
| 28        | PWREN    | Power interface clock enable<br>Set and cleared by software.<br>0: Power interface clock disabled<br>1: Power interface clock enable     |
| 27        | BKPEN    | Backup interface clock enable<br>Set and cleared by software.<br>0: Backup interface clock disabled<br>1: Backup interface clock enabled |
| 26        | CAN2EN   | CAN2 clock enable<br>Set and cleared by software.<br>0: CAN2 clock disabled<br>1: CAN2 clock enabled                                     |
| 25        | CAN1EN   | CAN1 clock enable<br>Set and cleared by software.<br>0: CAN1 clock disabled<br>1: CAN1 clock enabled                                     |
| 24        | Reserved | Reserved, the reset value must be maintained.  |
| 23        | USBEN    | USB clock enable<br>Set and cleared by software.<br>0: USB clock disabled<br>1: USB clock enabled  |

| Bit Field | Name      | Description   |
|-----------|-----------|---|
| 22        | I2C2EN    | I2C2 clock enable<br>Set and cleared by software.<br>0: I2C2 clock disabled<br>1: I2C2 clock enabled                                  |
| 21        | I2C1EN    | I2C1 clock enable<br>Set and cleared by software.<br>0: I2C1 clock disabled<br>1: I2C1 clock enabled                                  |
| 20        | UART5EN   | UART5 clock enable<br>Set and cleared by software.<br>0: UART5 clock disabled<br>1: UART5 clock enabled                               |
| 19        | UART4EN   | UART4 clock enable<br>Set and cleared by software.<br>0: UART4 clock disabled<br>1: UART4 clock enabled                               |
| 18        | USART3EN  | USART2 clock enable<br>Set and cleared by software.<br>0: USART3 clock disabled<br>1: USART3 clock enabled                            |
| 17        | USART2EN  | USART2 clock enable<br>Set and cleared by software.<br>0: USART2 clock disabled<br>1: USART2 clock enabled                            |
| 16        | Reserved  | Reserved, the reset value must be maintained.   |
| 15        | SPI3EN    | SPI3 clock enable<br>Set and cleared by software.<br>0: SPI3 clock disabled<br>1: SPI3 clock enabled                                  |
| 14        | SPI2EN    | SPI2 clock enable<br>Set and cleared by software.<br>0: SPI2 clock disabled<br>1: SPI2 clock enabled                                  |
| 13:12     | Reserved  | Reserved, the reset value must be maintained.   |
| 11        | WWDGEN    | Window watchdog clock enable<br>Set and cleared by software.<br>0: Window watchdog clock disabled<br>1: Window watchdog clock enabled |
| 10:8      | Reserved  | Reserved, the reset value must be maintained.   |
| 7         | COMPFLTEN | COMP Filter clock enable<br>Set and cleared by software.<br>0: COMP Filter clock disabled<br>1: COMP Filter clock enabled             |

| Bit Field | Name   | Description  |
|-----------|--------|--|
| 6         | COMPEN | COMP clock enable<br>Set and cleared by software.<br>0: COMP clock disabled<br>1: COMP clock enabled       |
| 5         | TIM7EN | TIM7 timer clock enable<br>Set and cleared by software.<br>0: TIM7 clock disabled<br>1: TIM7 clock enabled |
| 4         | TIM6EN | TIM6 timer clock enable<br>Set and cleared by software.<br>0: TIM6 clock disabled<br>1: TIM6 clock enabled |
| 3         | TIM5EN | TIM5 timer clock enable<br>Set and cleared by software.<br>0: TIM5 clock disabled<br>1: TIM5 clock enabled |
| 2         | TIM4EN | TIM4 timer clock enable<br>Set and cleared by software.<br>0: TIM4 clock disabled<br>1: TIM4 clock enabled |
| 1         | TIM3EN | TIM3 timer clock enable<br>Set and cleared by software.<br>0: TIM3 clock disabled<br>1: TIM3 clock enabled |
| 0         | TIM2EN | TIM2 timer clock enable<br>Set and cleared by software.<br>0: TIM2 clock disabled<br>1: TIM2 clock enabled |

### 6.3.10 Backup Domain Control Register (RCC\_BDCTRL)

Address offset: 0x20

Reset value: 0x0000 0000

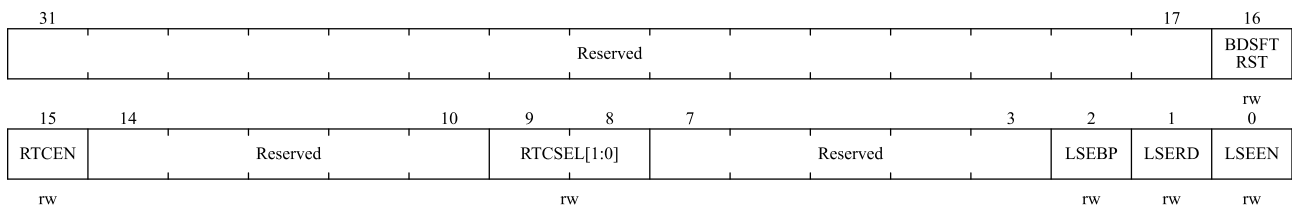

| Bit Field | Name     | Description                                   |
|-----------|----------|---|
| 31:17     | Reserved | Reserved, the reset value must be maintained. |
| 16        | BDSFTRST | Backup domain software reset.                 |

| Bit Field | Name        | Description  |
|-----------|-------------|--|
|           |             | Set or cleared by software.<br>0: No effect<br>1: Reset the entire backup domain   |
| 15        | RTCEN       | RTC clock enable<br>Set and cleared by software.<br>0: Disable RTC clock<br>1: Enable RTC clock  |
| 14:10     | Reserved    | Reserved, the reset value must be maintained.  |
| 9:8       | RTCSEL[1:0] | RTC clock source selection<br>Set by software to select RTC clock source. Once the RTC clock source is selected, it cannot be changed until the next backup domain is reset. These bits can be reset by setting the BDSFTRST bit.<br>00: No clock<br>01: LSE oscillator selected as RTC clock<br>10: LSI oscillator selected as RTC clock<br>11: HSE oscillator divided by 128 selected as RTC clock |
| 7:3       | Reserved    | Reserved, the reset value must be maintained.  |
| 2         | LSEBP       | External low-speed oscillator bypass<br>In debug mode, set and cleared by software to bypass oscillator. This bit can only be written when the external low-speed oscillator is disabled.<br>0: LSE oscillator not bypassed<br>1: LSE oscillator bypassed  |
| 1         | LSERD       | External low-speed clock oscillator ready<br>Set and cleared by hardware to indicate if the LSE oscillator is ready. After the LSEEN bit is cleared, LSERD goes low after 6 cycles of the LSE clock.<br>0: External low-speed oscillator not ready<br>1: External low-speed oscillator ready   |
| 0         | LSEEN       | External low-speed clock oscillator enable<br>Set and cleared by software.<br>0: Disable the external low-speed oscillator<br>1: Enable the external low-speed oscillator.   |

*Note: The `RCC_BDCTRL.LSEEN`, `RCC_BDCTRL.LSEBP`, `RCC_BDCTRL.RTCSEL` and `RCC_BDCTRL.RTCEN` bits are in the backup domain. Therefore, these bits are write-protected after reset and can only be changed after the `PWR_CTRL.DBKP` bit is set. These bits can only be cleared by a backup domain reset. Any internal or external reset will not affect these bits.*

### 6.3.11 Clock Control/Status Register (`RCC_CTRLSTS`)

Address offset: 0x24

Reset value: 0x0C000003

|           |           |           |          |          |         |          |        |          |          |          |          |          |          |       |       |
|-----------|-----------|-----------|----------|----------|---------|----------|--------|----------|----------|----------|----------|----------|----------|-------|-------|
| 31        | 30        | 29        | 28       | 27       | 26      | 25       | 24     | 23       | 22       | 21       | 20       | 19       | 18       | 16    |       |
| LPWR RSTF | WWDG RSTF | IWDG RSTF | SFT RSTF | POR RSTF | PINRSTF | MMU RSTF | RMRSTF | RAM RSTF | Reserved | BKP EMCF | RET EMCF | BOR RSTF | Reserved |       |       |
| r         | r         | r         | r        | r        | r       | r        | rw     | r        |          | r        | r        | r        |          |       |       |
| 15        |           |           |          |          |         |          |        |          |          |          |          |          | 2        | 1     | 0     |
|           |           |           |          |          |         |          |        |          |          |          |          |          | Reserved | LSIRD | LSIEN |
|           |           |           |          |          |         |          |        |          |          |          |          |          |          | r     | rw    |

| Bit Field | Name     | Description  |
|-----------|----------|--|
| 31        | LPWRRSTF | Low power reset flag<br>Set by hardware when a low-power management reset occurs.<br>Cleared by software by writing to the RMRSTF bit.<br>0: No low-power management reset occurred<br>1: A low-power management reset occurred          |
| 30        | WWDGRSTF | Window watchdog reset flag<br>Set by hardware when a window watchdog reset occurs.<br>Cleared by software by writing to the RMRSTF bit.<br>0: No windowed watchdog reset occurred<br>1: Window watchdog reset occurred                   |
| 29        | IWDGRSTF | Independent watchdog reset flag<br>Set by hardware when an independent watchdog reset occurs<br>Cleared by software by writing to the RMRSTF bit.<br>0: No independent watchdog reset occurred<br>1: Independent watchdog reset occurred |
| 28        | SFTRSTF  | Software reset flag<br>Set by hardware when a software reset occurs.<br>Cleared by software by writing to the RMRSTF bit.<br>0: No software reset occurred<br>1: Software reset occurred   |
| 27        | PORRSTF  | Power-on/power-down reset flag<br>Set by hardware when a power-on/power-down reset occurs<br>Cleared by software by writing to the RMRSTF bit.<br>0: No power on/power off reset occurred<br>1: Power-on/power-off reset occurred        |
| 26        | PINRSTF  | External pin reset flag<br>Set by hardware when a reset from the NRST pin occurs.<br>Cleared by software by writing to the RMRSTF bit.<br>0: No NRST pin reset occurred<br>1: NRST pin reset occurred                                    |
| 25        | MMURSTF  | MMU reset flag<br>Set by hardware when MMU reset occurs.<br>Cleared by software by writing to the RMRSTF bit.<br>0: No MMU reset occurred<br>1: MMU reset occurred   |
| 24        | RMRSTF   | Clear the reset flag<br>Set by the software to clear the reset flag.   |

| Bit Field | Name     | Description  |
|-----------|----------|--|
|           |          | 0: No effect<br>1: Clear the reset flag  |
| 23        | RAMRSTF  | RAM reset flag.<br>Set by hardware when a RAM reset occurs and cleared by software by writing to the RMRSTF bit.<br>0: No RAM reset occurred<br>1: A RAM reset has occurred  |
| 22        | Reserved | Reserved, the reset value must be maintained.  |
| 21        | BKPEMCF  | Backup domain EMC reset flag.<br>Set by hardware when a backup domain EMC reset occurs, and cleared by software writing the RMRSTF bit.<br>0: No backup domain EMC reset occurred<br>1: A backup domain EMC reset has occurred   |
| 20        | RETEMCF  | Retention domain EMC reset flag.<br>Set by hardware when a Retention domain EMC reset occurs, and cleared by software writing the RMRSTF bit.<br>0: No Retention domain EMC reset occurred<br>1: A Retention domain EMC reset has occurred   |
| 19        | BORRSTF  | BOR reset flag<br>Set by hardware when a BOR reset occurs, and cleared by software writing the RMRSTF bit.<br>0: No BOR reset occurred<br>1: A BOR reset has occurred  |
| 18:2      | Reserved | Reserved, the reset value must be maintained.  |
| 1         | LSIRD    | Internal low-speed oscillator ready<br>Set and cleared by hardware to indicate if the internal RC 40 KHz oscillator is ready. After LSIEN is cleared, LSIRD goes low after 3 internal RC 40 KHz oscillator clock cycles.<br>0: Internal 40KHz RC oscillator clock not ready<br>1: Internal 40KHz RC oscillator clock ready |
| 0         | LSIEN    | Internal low-speed oscillator enable<br>Set and cleared by software.<br>0: Disable the internal RC 40 kHz oscillator<br>1: Enable the internal RC 40 kHz oscillator  |

### 6.3.12 AHB Peripheral Reset Register (RCC\_AHBPRST)

Address offset: 0x28

Reset value: 0x0000 0000

|          |  |         |  |         |  |         |  |        |  |          |  |         |  |         |  |           |  |    |  |    |  |
|----------|--|---------|--|---------|--|---------|--|--------|--|----------|--|---------|--|---------|--|-----------|--|----|--|----|--|
| 31       |  |         |  |         |  |         |  |        |  |          |  |         |  | 18      |  |           |  | 17 |  | 16 |  |
| Reserved |  |         |  |         |  |         |  |        |  |          |  |         |  | QSPIRST |  | ETHMACRST |  |    |  |    |  |
|          |  |         |  |         |  |         |  |        |  |          |  |         |  | rw      |  | rw        |  |    |  |    |  |
| 15       |  | 14      |  | 13      |  | 12      |  | 11     |  | 10       |  | 9       |  | 8       |  | Reserved  |  |    |  |    |  |
| ADC4RST  |  | ADC3RST |  | ADC2RST |  | ADC1RST |  | SACRST |  | Reserved |  | RNGCRST |  |         |  |           |  |    |  |    |  |
| rw       |  | rw      |  | rw      |  | rw      |  | rw     |  |          |  | rw      |  |         |  |           |  |    |  |    |  |

| Bit Field | Name      | Description   |
|-----------|-----------|---|
| 31:18     | Reserved  | Reserved, the reset value must be maintained.   |
| 17        | QSPIRST   | QSPI reset<br>Set and cleared by software.<br>0: Clear the reset<br>1: Reset QSPI     |
| 16        | ETHMACRST | ETHMAC reset<br>Set and cleared by software.<br>0: Clear the reset<br>1: Reset ETHMAC |
| 15        | ADC4RST   | ADC4 reset<br>Set and cleared by software.<br>0: Clear the reset<br>1: Reset ADC4     |
| 14        | ADC3RST   | ADC3 reset<br>Set and cleared by software.<br>0: Clear the reset<br>1: Reset ADC3     |
| 13        | ADC2RST   | ADC2 reset<br>Set and cleared by software.<br>0: Clear the reset<br>1: Reset ADC2     |
| 12        | ADC1RST   | ADC1 reset<br>Set and cleared by software.<br>0: Clear the reset<br>1: Reset ADC1     |
| 11        | SACRST    | SAC reset<br>Set and cleared by software.<br>0: Clear the reset<br>1: Reset SAC       |
| 10        | Reserved  | Reserved, the reset value must be maintained.   |
| 9         | RNGCRST   | RNGC reset<br>Set and cleared by software.<br>0: Clear the reset<br>1: Reset RNGC     |
| 8:0       | Reserved  | Reserved, the reset value must be maintained.   |

### 6.3.13 Clock Configuration Register 2 (RCC\_CFG2)

Address offset: 0x2c

Reset value: 0x0000 3800

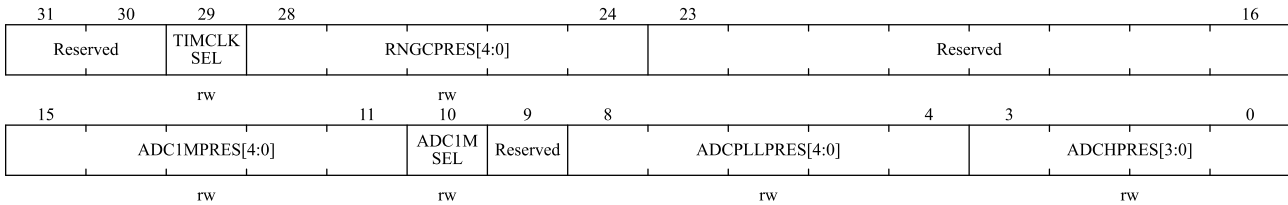

| Bit Field | Name           | Description  |
|-----------|----------------|--|
| 31:30     | Reserved       | Reserved, the reset value must be maintained.  |
| 29        | TIMCLKSEL      | TIM1/8 clock source selection<br>Set and cleared by software.<br>0: PCLK2 is selected as TIM1/8 clock source if APB2 prescaler is 1. Otherwise, PCLK2 × 2 is selected.<br>1: SYSCLK input clock is selected as TIM1/8 clock source.  |
| 28:24     | RNGCPRES[4:0]  | RNGC prescaler.<br>Software sets or clears these bits to configure the prescale factor for the RNGC clock.<br>00000: SYSCLK is not divided<br>00001: SYSCLK divided by 2<br>00010: SYSCLK divided by 3<br>...<br>11110: SYSCLK divided by 31<br>11111: SYSCLK divided by 32  |
| 23:16     | Reserved       | Reserved, the reset value must be maintained.  |
| 15:11     | ADC1MPRES[4:0] | ADC 1M clock prescaler<br>Set and cleared by software to configure the division factor of ADC 1M clock source.<br>00000: ADC 1M clock source not divided<br>00001: ADC 1M clock source divided by 2<br>00010: ADC 1M clock source divided by 3<br>...<br>11110: ADC 1M clock source divided by 31<br>11111: ADC 1M clock source divided by 32<br><i>Note: ADC clock must be configured to 1M</i> |
| 10        | ADC1MSEL       | ADC 1M clock source selection.<br>Set or cleared by software.<br>0: Select HSI oscillator clock as the input clock of ADC 1M<br>1: Select HSE oscillator clock as the input clock of ADC 1M  |
| 9         | Reserved       | Reserved, the reset value must be maintained.  |

| Bit Field | Name            | Description  |
|-----------|-----------------|--|
| 8:4       | ADCPLLPRES[4:0] | ADC PLL prescaler<br>Set and cleared by software to configure the division factor from the PLL clock to the ADC.<br>0xxxx: ADC PLL clock is disabled<br>10000: PLL clock not divided<br>10001: PLL clock divided by 2<br>10010: PLL clock divided by 4<br>10011: PLL clock divided by 6<br>10100: PLL clock divided by 8<br>10101: PLL clock divided by 10<br>10110: PLL clock divided by 12<br>10111: PLL clock divided by 16<br>11000: PLL clock divided by 32<br>11001: PLL clock divided by 64<br>11010: PLL clock divided by 128<br>11011: PLL clock divided by 256<br>Others: PLL clock divided by 256 |
| 3:0       | ADCHPRES[3:0]   | ADC HCLK prescaler<br>Set and cleared by software to configure the division factor from the HCLK clock to the ADC.<br>0000: HCLK clock not divided<br>0001: HCLK clock divided by 2<br>0010: HCLK clock divided by 4<br>0011: HCLK clock divided by 6<br>0100: HCLK clock divided by 8<br>0101: HCLK clock divided by 10<br>0110: HCLK clock divided by 12<br>0111: HCLK clock divided by 16<br>1000: HCLK clock divided by 32<br>Others: HCLK clock divided by 32   |

### 6.3.14 Clock Configuration Register 3 (RCC\_CFG3)

Address offset: 0x30

Reset value: 0x0000 3800

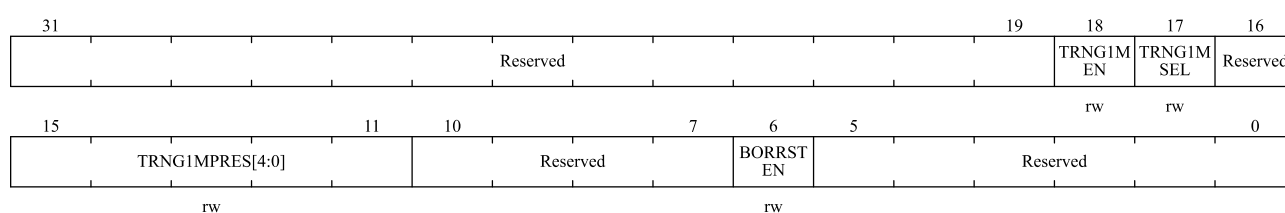

| Bit Field | Name            | Description  |
|-----------|-----------------|--|
| 31:19     | Reserved        | Reserved, the reset value must be maintained.  |
| 18        | TRNG1MEN        | TRNG analog interface clock enable.<br>Set or cleared by software.<br>0: Disable TRNG analog interface clock<br>1: Enable TRNG analog interface clock  |
| 17        | TRNG1MSEL       | TRNG 1M clock selection.<br>Set or cleared by software.<br>0: Select HSI oscillator as TRNG 1M input clock<br>1: Select HSE oscillator as TRNG 1M input clock  |
| 16        | Reserved        | Reserved, the reset value must be maintained.  |
| 15:11     | TRNG1MPRES[4:0] | TRNG 1M clock prescaler.<br>Software sets or clears these bits to generate the TRNG 1M clock.<br>0000x: TRNG 1M clock source divided by 2<br>0001x: TRNG 1M clock source divided by 4<br>0010x: TRNG 1M clock source divided by 6<br>0011x: TRNG 1M clock source divided by 8<br>0100x: TRNG 1M clock source divided by 10<br>...<br>1111x: TRNG 1M clock source divided by 32 |
| 10:7      | Reserved        | Reserved, the reset value must be maintained.  |
| 6         | BORRSTEN        | BOR reset enable<br>Set and cleared by software.<br>0: Disable BOR reset<br>1: Enable BOR reset  |
| 5:0       | Reserved        | Reserved, the reset value must be maintained.  |

## 7 GPIO and AFIO

### 7.1 Summary

GPIO is general purpose input/output, and AFIO is alternate function input/output. Up to 97 GPIO are supported on the chip, which are divided into 7 groups (GPIOA/GPIOB/GPIOC/GPIOD/GPIOE/GPIOF/GPIOG ) with 16 ports in each group (10 in group F and 7 in group G). GPIO port and other alternate peripherals share pins, which can be configured by users according to requirements. Each GPIO pin can be independently configured as an output, input or alternate peripheral function port. Except for the analog function pin, all other GPIO pins have the ability to pass large current.

GPIO ports can be configured in the following modes by software:

- Input floating
- Input pull-up
- Input pull-down
- Analog function
- Open drain output
- Push-pull output
- Push-pull alternate function
- Open-drain alternate function

Each I/O port bit can be programmed arbitrarily, but the I/O port register must be accessed as a 32-bit word (16-bit half word or 8-bit byte access is not allowed). The figure below shows the basic structure of an I/O port.

Figure 7-1 Basic structure of I/O port

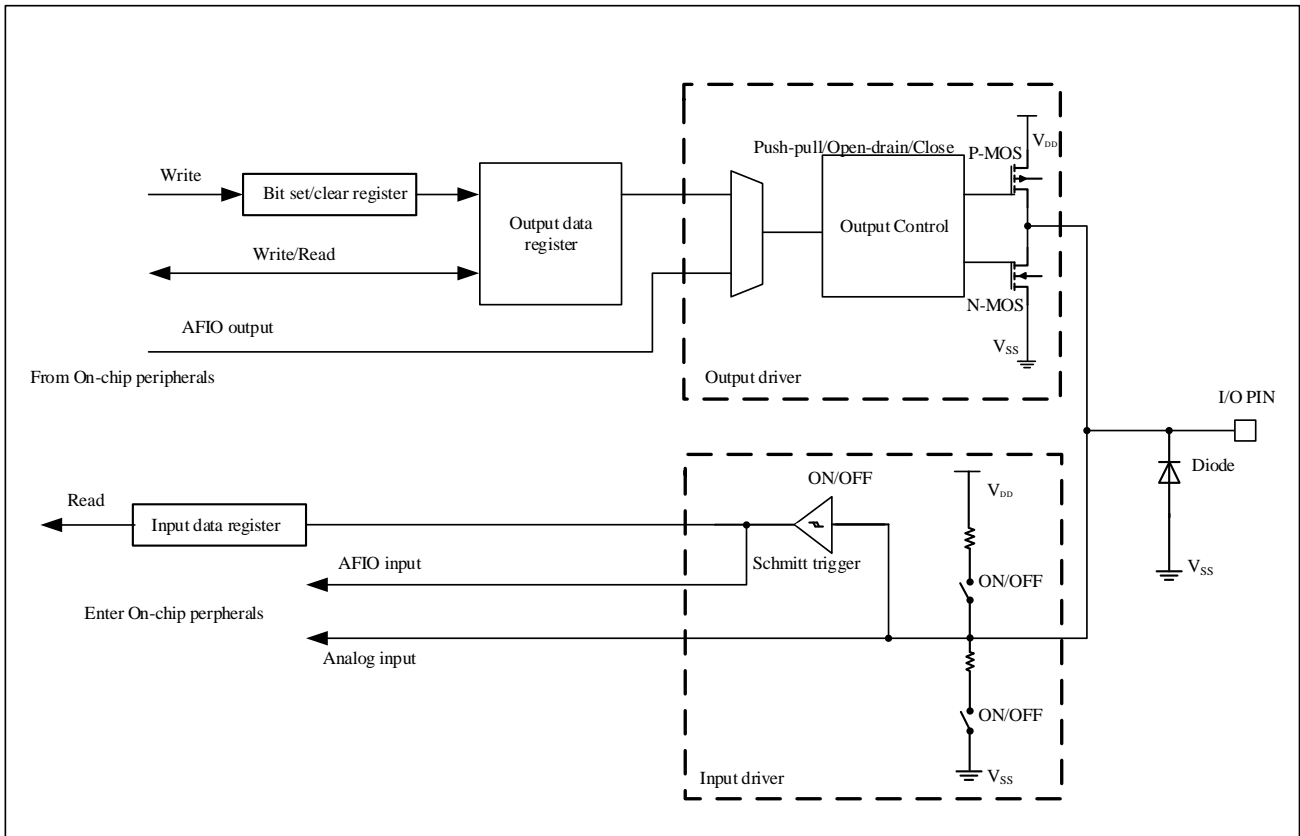

## 7.2 I/O function description

### 7.2.1 I/O mode configuration

I/O mode control is set by configuration registers GPIOx\_PL\_CFG, GPIOx\_PH\_CFG and output register GPIOx\_POD(x=A,B,C,D,E,F,G). The I/O configurations in different operation modes are shown in the following table:

Table 7-1 I/O mode and configuration relationship

| Configuration mode        |                 | PCFG1 | PCFG0 | PMODE1  | PMODE0 | PODx register |         |
|---------------------------|-----------------|-------|-------|---|--------|---------------|---------|
| Universal output          | Push-Pull       | 0     | 0     | 01: 10MHz max<br>10: 2MHz max<br>1: 50MHz max |        | 0 or 1        |         |
|                           | Open-Drain      |       | 1     |   |        | 0 or 1        |         |
| Alternate function output | Push-Pull       | 1     | 0     |   |        |               | Not use |
|                           | Open-Drain      |       | 1     |   |        | Not use       |         |
| Input                     | Analog mode     | 0     | 0     | 00: reserved                                  |        | Not use       |         |
|                           | Input floating  |       | 1     |   |        | Not use       |         |
|                           | Input pull-down | 1     | 0     |   |        | 0             |         |
|                           | Input pull-up   |       |       |   |        | 1             |         |

I/O characteristics under different configurations are shown in the following table:

Table 7-2 I/O characteristics of different I/O configurations

| Characteristic                     | GPIO input   | GPIO output   | Analog mode                                 | Peripheral alternate   |
|------------------------------------|--------------|---|---|--|
| Output buffer                      | Disable      | Enable  | Disable                                     | According to peripheral function configuration   |
| Schmitt trigger                    | Enable       | Enable  | Disable<br>The output value is forced to 0. | According to peripheral function configuration   |
| Pull up/Pull down/floating         | Configurable | Disable   | Disable                                     | According to peripheral function configuration   |
| Open-drain mode                    | Disable      | Configurable, GPIO outputs 0 when the data is "0" and high impedance when the data is "1" | Disable                                     | Configurable, GPIO outputs 0 when the data is "0" and high impedance when the data is "1". |
| Input data register (I/O status)   | Read-write   | Readable  | Read as 0.                                  | Readable   |
| Output data register (write value) | Invalid      | Read-write  | Invalid                                     | Readable   |

### 7.2.1.1 Input mode

When I/O port is configured in input mode:

- The data that appears on the I/O pin is sampled to the input data register on each APB2 clock.
- Read access to the input data register can get I/O status.
- Output buffer is disabled.
- Schmidt trigger input is activated.
- Weak pull-up and pull-down resistors are connected according to the input configuration (pull-up, pull-down or floating).

Figure 7-2 Input float/pull-up/pull-down configuration

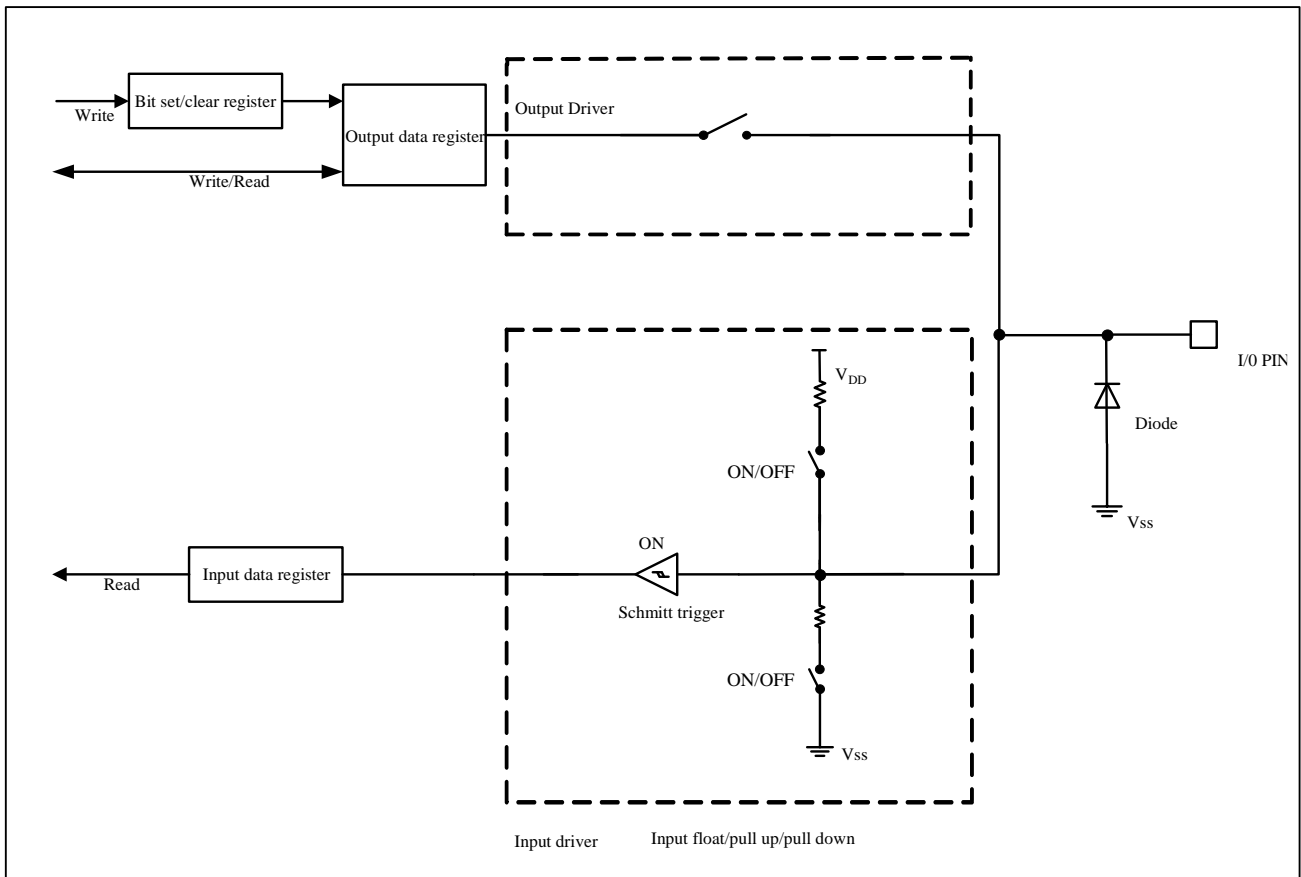

### 7.2.1.2 Output mode

When I/O port is configured as output mode:

- Schmidt trigger input is activated
- Weak pull-up and pull-down resistors are disabled.
- Output buffer is activated.
  - ◆ Open-drain mode: '0' on the output register activates N-MOS, and the pin outputs low level. '1' port on the output register make the pin in a high impedance state (P-MOS is never activated)
  - ◆ Push-pull mode: '0' on the output register activates N-MOS, and the pin outputs low level. '1' on the output register activates P-MOS, and the pin outputs high level.
- The data appearing on the I/O pin is sampled to the input data register at every APB2 clock cycle..
- Read access to the input data register can get I/O status.
- The read access to the output data register gets the last written value.

Figure 7-3 Output mode configuration

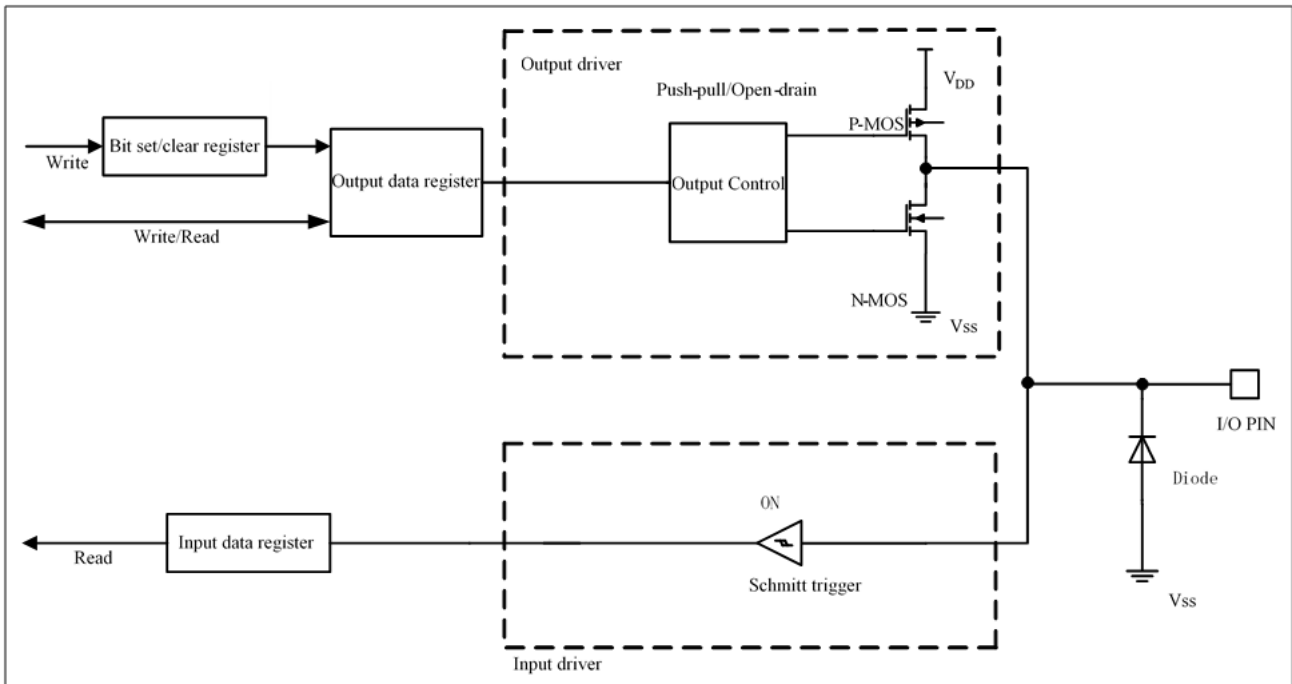

### 7.2.1.3 Alternate function mode

When I/O ports are configured for alternate function mode:

- Schmitt trigger input is activated.
- Weak pull-up and pull-down resistors are disabled.
- In the open-drain or push-pull configuration, the output buffer is turned on.
- Signals of built-in peripherals drive the output buffer.
- The data appearing on the I/O pin is sampled to the input data register at every APB2 clock cycle.
- I/O status can be obtained by reading and accessing the input data register.
- The read access to the output data register gets the last written value.

Figure 7-4 Alternate function configuration

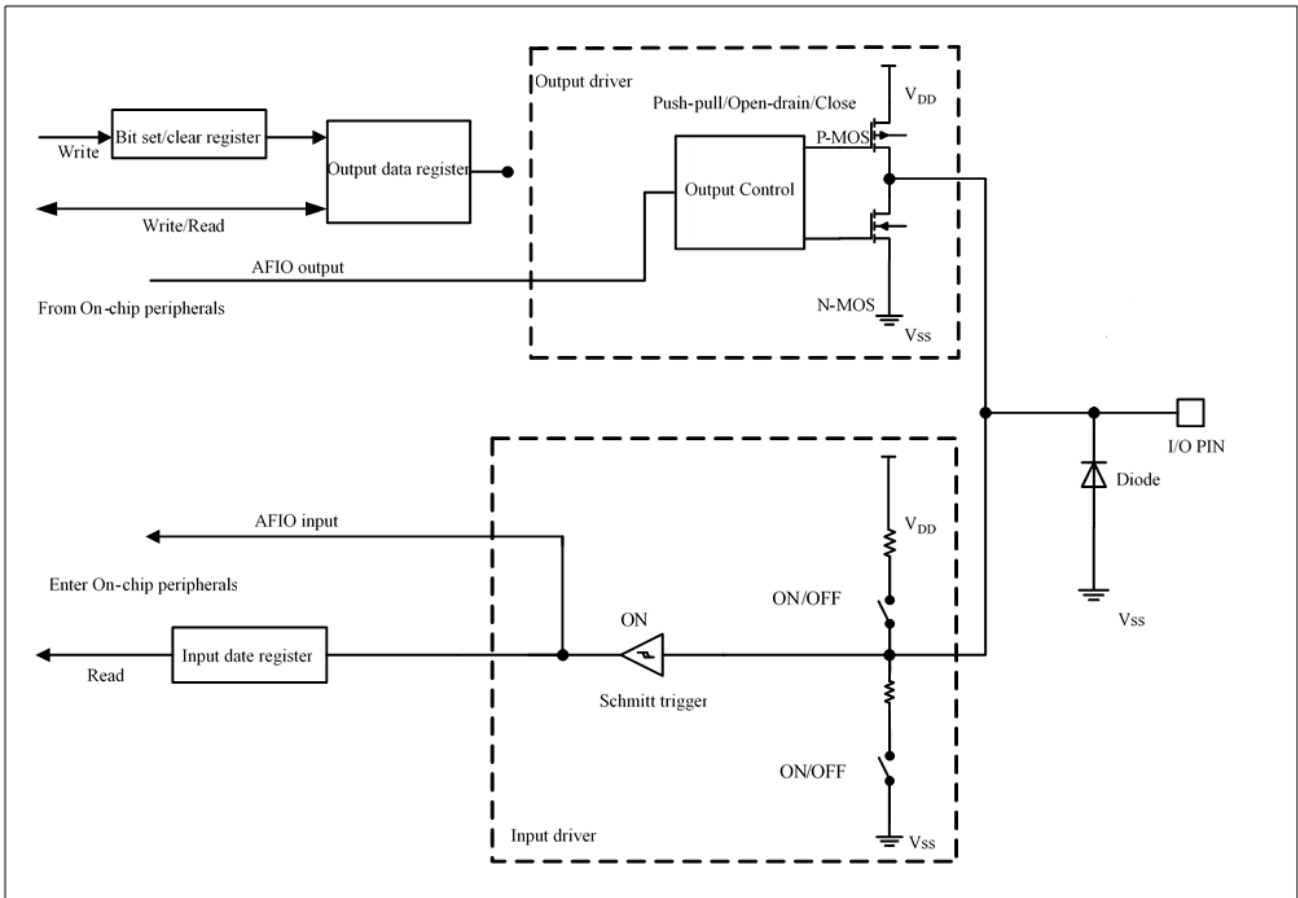

### 7.2.1.4 Analog mode

When the I/O port is configured in analog mode:

- Weak pull-up and pull-down resistors are disabled.
- Read access to the input data register gets the value "0".
- Output buffer is disabled.
- Schmitt trigger input is disabled and output value is forced to '0' (zero consumption on each analog I / O pin is achieved)

Figure 7-5 High impedance analog mode configuration

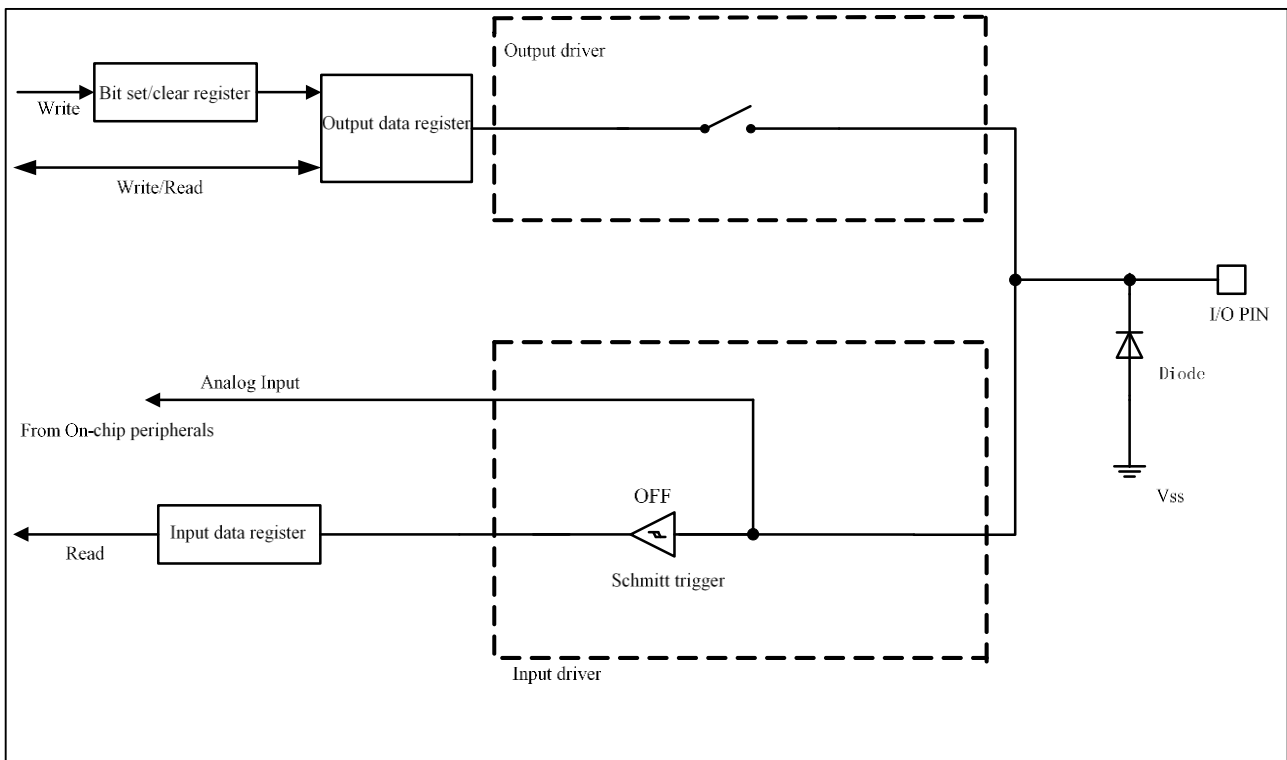

## 7.2.2 Status after reset

During and just after the reset, the alternate functions are not active, and the I/O port is configured to be in analog mode (PCFGy[1:0]=00b, PMODEy[1:0]=00b) by default. But there are several exceptional signals:

- BOOT0、NRST、OSC\_IN、OSC\_OUT has no GPIO function by default
  - ◆ BOOT0 pin default configuration is input pull down
  - ◆ NRST pull up input and output
- After the reset, the default state of the pin associated with the debug system is to enable the SWD-JTAG, and the JTAG pin is placed on the input pull-up or pull-down mode
  - PA15: JTDI is placed in input pull-up mode
  - PA14: JTCK is placed in input pull-down mode
  - PA13: JTMS is placed in input pull-up mode
  - PB4: NJTRST is placed in input pull-up mode
  - ◆ PB3:JTD0 is placed in the push-pull output without pull-down.
- PD0 and PD1:
  - ◆ PD0 and PD1 default to analog mode in 80 and above pin packages.
  - ◆ PD0 and PD1 are multiplexed to OSC\_IN/OUT for pin packages with less than 80 pins.
- PC13、PC14、PC15:

- ◆ PC13~15 are the three IOs in the backup domain. After the backup domain is powered on for the first time, these three IOs default to analog mode;
- PB2/BOOT1:
  - ◆ PB2/BOOT1 is in the pull-down input state by default;
  - ◆ BOOT0 default configuration is input pull-down. Refer to the following Table (If the BOOT pins are not connected, the main flash storage area is selected by default).

| Start mode select pin |       | Start mode        | Description                                    |
|-----------------------|-------|-------------------|--|
| BOOT1                 | BOOT0 |                   |  |
| x                     | 0     | Main flash memory | The main flash memory serves as the boot area. |
| 0                     | 1     | System memory     | System memory as boot area                     |
| 1                     | 1     | Built in SRAM     | Built-in SRAM as startup area                  |

### 7.2.3 Individual bit setting and bit clearing

By writing '1' to the bit to be changed in the set register (GPIOx\_PBSC) and reset register (GPIOx\_PBC), the individual bit operation of the data register (GPIOx\_POD) can be realized, and one or more bits can be set/reset. The bit written with '1' is set or cleared accordingly, and the bit not written with '1' will not be changed. The software does not need to disable interrupts, and is completed in a single APB2 write operation.

### 7.2.4 External interrupt/wake-up line

All ports have external interrupt capability, which can be configured in EXTI module:

- The port must be configured in input mode.
- All ports can be configured for wake-up in SLEEP/STOP0/STOP2 mode, and the rising or falling edge can be configured.
- PA0 can be used to wake up in STANDBY mode.
- The general purpose I/O port (as shown in External interrupt GPIO mapping) is connected to 16 external interrupt/event lines and is configured by register AFIO\_EXTI\_CFGx.

### 7.2.5 Alternate function

When I/O ports are configured for alternate function mode, the port bit configuration register (GPIOx\_PL\_CFG/GPIOx\_PH\_CFG) must be programmed before use, as follows:

- Input alternate function: The port must be configured in input mode (floating, pull-up or pull-down) and the input pin must be externally driven.
- Output alternate function: The port must be configured to alternate output mode (push-pull or open-drain).
- Bidirectional alternate function: The port bit must be configured with the alternate function output mode (push-pull or open-drain). At this time, the input driver is configured to input floating mode.

In the output alternate function mode, the pin is disconnected from the output data register and connected with the

output signal of the on-chip peripheral. If the software configures a GPIO pin as output alternate function, but the peripheral is not activated, then its output will be uncertain.

### 7.2.5.1 Clock output MCO

The microcontroller allows the clock signal to be output to the external MCO pin (PA8). PA8 must be configured to push-pull alternate output function mode. The following four clock signals can be selected as MCO clocks, and the selection of the clock is controlled by `RCC_CFG.MCO[2:0]` bits:

- SYSCLK divided clock
- HSI
- HSE
- PLL divided clock

### 7.2.5.2 Software remapping I/O alternate function

In order to expand the flexibility of alternate peripheral functions under different device packages, some peripheral alternate functions can be remapped to other pins. You can configure the corresponding register (`AFIO_RMP_CFG`, `AFIO_RMP_CFGx`) by software. At this time, the alternate function is disconnected from its original pin and remapped to the new pin.

*Note: When the I/O pin mapped by the peripheral is in a non-default alternate function (`REMAP != "00"`), if the I/O is used as an output, glitches may occur on the default alternate function pin upon reset. For example: when `TIM4_CH1` is remapped to `PD12` (`TIM4_REMAP = "01"`), if a reset occurs, glitches may appear on `PB6` (`TIM4_REMAP = "00"`).*

### 7.2.5.3 Functional remapping of backup domain pins PC13~PC15

#### 7.2.5.3.1 Functional description of backup power domain pins PC13~PC15

PC13~PC15 pins are located in the backup domain and can be used in GPIO mode or alternate function mode:

- When the backup domain is powered by VDD (internal analog switch connected to VDD), the following functions are available:
  - ◆ PC14 and PC15 can be used for GPIO or LSE pins.
  - ◆ PC13 can be used as a general-purpose I/O port, TAMPER pin, RTC calibration clock, RTC alarm clock or second output (see backup register 5.4 chapter)

*Note: Because the analog switch can only pass low current (3mA), the functions of I/O ports of PC13, PC14, PC15 in the output mode are limited: the speed must be limited below 2MHz, the maximum load is 30pF, and these I/O ports must not be used as current sources (such as driving LEDs).*

- When the backup domain is powered by VBAT (the analog switch is connected to VBAT after VDD is off), the following functions can be used:
  - ◆ PC14 and PC15 can only be used for LSE pins.
  - ◆ PC13 can be used as a TAMPER pin, RTC alarm clock or second output (see 14.2.8), and output RTC calibration clock, RTC alarm clock pulse or second pulse on PC13 pin (when this pin is not used for intrusion detection). For the convenience of measurement, the RTC clock can be divided by 64 and output to the intrusion detection pin TAMPER. Turn on this function by setting the `RTC_CTRL.COEN` bit.

### 7.2.5.3.2 PC13~PC15 function mapping

According to the previous description, the configuration conditions of different modes of PC13~PC15 are sorted out as follows:

| PC14 and PC15  | condition  | PAD mode configuration                       |
|--|--|--|
| GPIO mode  | LSE is off, the backup domain is powered by VDD, and it can only be used in GPIO mode when the 1.1V power supply is turned off without entering the low power mode(Standby, Stop2)           | The mode of GPIO depends on the application. |
| LSE mode   | The LSE priority is high, and the LSE mode will be entered if the above conditions are not met.  | Analog mode                                  |
| PC13   | condition  | PAD mode configuration                       |
| GPIO mode  | The backup domain is powered by VDD, and can only be used in GPIO mode when the 1.1V power supply is turned off without entering the the low power mode(Standby, Stop2)                      | The mode of GPIO depends on the application. |
| TAMPER pin   | You can configure this input at any time.  | Input floating                               |
| RTC calibration clock, RTC alarm clock pulse or second pulse | When this pin is not used for intrusion detection, it can be used to output RTC calibration clock, RTC alarm clock pulse or second pulse, so the priority is lower than the TAMPER function. | Alternate push-pull output                   |

From the above, the power domain division managed by the three pins PC13~PC15:

- GPIOx\_PH\_CFG/GPIOx\_PID/GPIOx\_POD/GPIOx\_PBSC/GPIOx\_PBC/GPIOx\_PLOCK\_CFG and other GPIO related configuration registers are in the Core power domain;

- The Mux logic of these three pins are in VBAT domain, and the default mode is GPIO input floating mode; PC14 and PC15 decide which mode and Mux they are in according to LSEEN, backup domain power supply control signal, chip mode signal, GPIOC\_PH\_CFG, TAMPER and clock output control.

*Note: The control signal of whether the backup domain is powered by VDD or VBAT is automatically switched by PWR module, which should be obtained by POR signal of VDD domain.*

### 7.2.5.4 Use the OSC\_IN/OSC\_OUT pin as the GPIO port PD0/PD1

If the external high-speed oscillator is not turned on in the application, the pin OSC\_IN/OSC\_OUT can be used as PD0/PD1 of GPIO, which is realized by setting the alternate remapping and debugging I/O configuration register (AFIO\_RMP\_CFG), as described below:

|        |  |
|--------|--|
| Bit 15 | <p>PD01_RMP: PD0/ PD1 is mapped to OSC_in/OSC_out (PD0/PD1 mapping on OSC_IN/OSC_OUT)</p> <p>This bit can be set to '1' or '0' by software. It controls the GPIO function image of PD0 and PD1. PD0 and PD1 can be mapped to the OSC_IN and OSC_OUT pins when the main oscillator HSE is not used (the system runs on the internal 8MHz RC oscillator).</p> <p>0: Do not remap PD0 and PD1;</p> <p>1: PD0 is mapped to OSC_in, and pd1 is mapped to OSC_OUT.</p> <p>This function can only be applied to 48-pin and 64-pin packages (there are PD0 and PD1 on 80-pin, 100-pin and 128-pin packages, and there is no need to remap them).</p> |
|--------|--|

*Note: The external interrupt/event function has not been remapped. On 48-pin and 64-pin packages, PD0 and PD1 cannot be used to generate external interrupts/events. That is, for LQFP48/64 package, there are only two pins OSC\_IN and OSC\_OUT (without PD0 and PD1), which can be mapped to PD0 and PD1 when external crystal oscillator is not used. For 80-pin and above packages, PD0 and PD1 pins are available, and OSC\_IN and OSC\_OUT are available, so there is no need to remap PD0/ PD1 to OSC\_IN/OSC\_OUT.*

*Note: When OSC\_IN and OSC\_OUT are remapped as PD0/PD1 (GPIO function), HSE enable must be disabled.*

### 7.2.5.5 JTAG/SWD alternate function remapping

The SWD-JTAG debug interface is enabled by default when the chip is powered on, and the debug interface is mapped to the GPIO port, as shown in the following Table.

| Alternate function | GPIO port |
|--------------------|-----------|
| JTMS/SWDIO         | PA13      |
| JTCK/SWCLK         | PA14      |
| JTDI               | PA15      |
| JTDO               | PB3       |
| NJTRST             | PB4       |

If you need to use its GPIO function during debugging, you can set the AFIO\_RMP\_CFG.SW\_JTAG\_CFG[2:0] bits can change the above remapping configuration. See the Table below.

Table 7-3 Debug port image

| SW_JTAG_CFG[2:0] | Possible debug ports for                               | SWJ I/O pin allocation  |                         |                      |                      |                      |
|------------------|--|-------------------------|-------------------------|----------------------|----------------------|----------------------|
|                  |  | PA13/<br>JTMS/<br>SWDIO | PA14/<br>JTCK/<br>SWCLK | PA15/ JTDI           | PB3/<br>JTDO         | PB4/<br>NJTRST       |
| 000              | Complete SWJ(JTAG-DP+SW-DP)<br>(reset state)           | I/O is not available    | I/O is not available    | I/O is not available | I/O is not available | I/O is not available |
| 001              | Complete SWJ(JTAG-DP+SW-DP)<br>But there is no NJTRST. | I/O is not available    | I/O is not available    | I/O is not available | I/O is not available | I/O available        |
| 010              | Turn off JTAG-DP and enable SW-DP.                     | I/O is not available    | I/O is not available    | I/O available        | I/O available        | I/O available        |
| 100              | Turn off JTAG-DP and SW-DP.                            | I/O available           | I/O available           | I/O available        | I/O available        | I/O available        |
| other            | Forbidden  |                         |                         |                      |                      |                      |

### 7.2.5.5.1 SWJ\_CFG configuration items

When the write buffer of APB bridge is full, one more APB cycle is needed when writing AFIO\_RMP\_CFG register. This is because the release of SWD\_JTAG pin takes two APB cycles to ensure that the input signals of NJTRST and JTCK are clean.

The first cycle: the signal input to the kernel by SWD\_JTAG with I/O input is connected to 0 or 1 (NJTRST /TDI/TMS is connected to 1, JTCK is connected to 0);

Second cycle: IOM controls the control signals of SWD\_JTAG pin (such as direction, pull-down, schmidt input, etc.).

### 7.2.5.5.2 Pull-down configuration

Since the pins of JTAG are directly connected to the internal debug register (JTCK/SWCLK is directly connected to the clock terminal), it is necessary to ensure that the input pins of JTAG cannot be floating. In order to avoid any uncontrollable I/O level, JTAG's input pin is fixed with internal pull-down and pull-up:

- NJTRST: internal pull-up
- JTDI: Internal pull-up
- JTMS/SWDIO: Internal pull-up
- JTCK/SWCLK: Internal pull-down

### 7.2.5.6 ADC external trigger alternate function remapping

The external trigger source of injection conversion and regular conversion of ADC supports remapping. See alternate remapping and debug I/O configuration register (AFIO\_RMP\_CFG).

Table 7-4 ADC1 external trigger injection conversion alternate function remapping

| Alternate function                         | ADC1_ETRI = 0  | ADC1_ETRI = 1   |
|--|--|---|
| ADC1 external trigger injection conversion | ADC1 external trigger injection conversion is connected to EXTI15. | ADC1 external trigger injection conversion is connected to TIM8_CH4 |

Table 7-5 ADC1 external trigger regular conversion alternate function remapping

| Alternate function                    | ADC1_ETRR = 0  | ADC1_ETRR = 1  |
|---------------------------------------|--|--|
| ADC1 external trigger rule conversion | ADC1 external trigger regular conversion is connected to EXTI11. | ADC1 external trigger regular conversion is connected to TIM8_TRGO |

Table 7-6 ADC2 external trigger injection conversion alternate function remapping

| Alternate function                         | ADC2_ETRI = 0  | ADC2_ETRI = 1   |
|--|--|---|
| ADC2 external trigger injection conversion | ADC2 external trigger injection conversion is connected to EXTI15. | ADC2 external trigger injection conversion is connected to TIM8_CH4 |

Table 7-7 ADC2 external trigger regular conversion alternate function remapping

| Alternate function                    | ADC2_ETRR = 0  | ADC2_ETRR = 1  |
|---------------------------------------|--|--|
| ADC2 external trigger rule conversion | ADC2 external trigger regular conversion is connected to EXTI11. | ADC2 external trigger regular conversion is connected to TIM8_TRGO |

Table 7-8 ADC3 external trigger injection conversion alternate function remapping

| Alternate function | ADC3_ETRI = 0 | ADC3_ETRI = 1 |
|--------------------|---------------|---------------|
|                    |               |               |

|  |  |   |
|--|--|---|
| ADC3 external trigger injection conversion | ADC3 external trigger injection conversion is connected to EXTI14. | ADC3 external trigger injection conversion is connected to TIM5_CH4 |
|--|--|---|

Table 7-9 ADC3 external trigger regular conversion alternate function remapping

| Alternate function                    | ADC3_ETRR = 0  | ADC3_ETRR = 1   |
|---------------------------------------|--|---|
| ADC3 external trigger rule conversion | ADC3 external trigger regular conversion is connected to EXTI10. | ADC3 external trigger regular conversion is connected to TIM5_CH3 |

Table 7-10 ADC4 external trigger injection conversion alternate function remapping

| Alternate function                         | ADC4_ETRI = 0  | ADC4_ETRI = 1   |
|--|--|---|
| ADC4 external trigger injection conversion | ADC4 external trigger injection conversion is connected to EXTI14. | ADC4 external trigger injection conversion is connected to TIM5_CH4 |

Table 7-11 ADC4 external trigger regular conversion alternate function remapping

| Alternate function                    | ADC4_ETRR = 0  | ADC4_ETRR = 1   |
|---------------------------------------|--|---|
| ADC4 external trigger rule conversion | ADC4 external trigger regular conversion is connected to EXTI10. | ADC4 external trigger regular conversion is connected to TIM5_CH3 |

### 7.2.5.7 TIMx alternate function remapping

Table 7-12 TIM5 alternate function remapping

| Alternate function | TIM5CH4_RMP = 0              | TIM5CH4_RMP = 1   |
|--------------------|------------------------------|---|
| TIM5_CH4           | TIM5_CH4 is connected to PA3 | The LSI internal oscillator is connected to TIM5_CH4 to calibrate the LSI |

Table 7-13 TIM4 alternate function remapping

| Alternate function | TIM4_RMP = 0 | TIM4_RMP = 1 |
|--------------------|--------------|--------------|
| TIM4_ETR           | PE0          |              |
| TIM4_CH1           | PB6          | PD12         |
| TIM4_CH2           | PB7          | PD13         |
| TIM4_CH3           | PB8          | PD14         |
| TIM4_CH4           | PB9          | PD15         |

Table 7-14 TIM3 alternate function remapping

| Alternate function | TIM3_RMP[1:0] = 00<br>(No remapping) | TIM3_RMP[1:0] = 10<br>(partial remapping) | TIM3_RMP[1:0] = 11<br>(Full remapping) |
|--------------------|--------------------------------------|---|--|
| TIM3_ETR           | PD2                                  |   |  |
| TIM3_CH1           | PA6                                  | PB4                                       | PC6                                    |
| TIM3_CH2           | PA7                                  | PB5                                       | PC7                                    |
| TIM3_CH3           | PB0                                  |   | PC8                                    |
| TIM3_CH4           | PB1                                  |   | PC9                                    |

Table 7-15 TIM2 alternate function remapping

| Alternate function | TIM2_RMP[1:0] = 00 | TIM2_RMP[1:0] = 01 | TIM2_RMP[1:0] = 10 | TIM2_RMP[1:0] = 11 |
|--------------------|--------------------|--------------------|--------------------|--------------------|
|                    |                    |                    |                    |                    |

|              | (No remapping) | (Partial remapping) | (Partial remapping) | (Full remapping) |
|--------------|----------------|---------------------|---------------------|------------------|
| TIM2_CH1_ETR | PA0            | PA15                | PA0                 | PA15             |
| TIM2_CH2     | PA1            | PB3                 | PA1                 | PB3              |
| TIM2_CH3     | PA2            |                     | PB10                |                  |
| TIM2_CH4     | PA3            |                     | PB11                |                  |

Table 7-16 TIM1 alternate function remapping

| Alternate function | TIM1_RMP[1:0] = 00<br>(No remapping) | TIM1_RMP[1:0] = 01<br>(Partial remapping) | TIM1_RMP[1:0] = 10<br>(Partial remapping) | TIM1_RMP[1:0] = 11<br>(Full remapping) |
|--------------------|--------------------------------------|---|---|--|
| TIM1_ETR           | PA12                                 |   | PA12                                      | PE7                                    |
| TIM1_CH1           | PA8                                  |   | PA8                                       | PE9                                    |
| TIM1_CH2           | PA9                                  |   | PA9                                       | PE11                                   |
| TIM1_CH3           | PA10                                 |   | PA10                                      | PE13                                   |
| TIM1_CH4           | PA11                                 |   | PA11                                      | PE14                                   |
| TEAM1_BKIN         | PB12                                 | PA6                                       | PB5                                       | PE15                                   |
| TIM1_CH1N          | PB13                                 | PA7                                       | PB13                                      | PE8                                    |
| TIM1_CH2N          | PB14                                 | PB0                                       | PB14                                      | PE10                                   |
| TIM1_CH3N          | PB15                                 | PB1                                       | PB15                                      | PE12                                   |

Table 7-17 TIM8 alternate function remapping

| Alternate function | TIM8_RMP[1:0] = 00<br>(No remapping) | TIM8_RMP[1:0] = 01<br>(Partial remapping) | TIM8_RMP[1:0] = 11<br>(Full remapping) |
|--------------------|--------------------------------------|---|--|
| TIM8_ETR           | PA0                                  | PB4                                       | PB4                                    |
| TIM8_CH1           | PC6                                  | PC6                                       | PD14                                   |
| TIM8_CH2           | PC7                                  | PC7                                       | PD15                                   |
| TIM8_CH3           | PC8                                  | PC8                                       | PC8                                    |
| TIM8_CH4           | PC9                                  | PC9                                       | PC9                                    |
| TEAM8_BKIN         | PA6                                  | PB3                                       | PB3                                    |
| TIM8_CH1N          | PA7                                  | PA15                                      | PA15                                   |
| TIM8_CH2N          | PB0                                  | PC12                                      | PC12                                   |
| TIM8_CH3N          | PB1                                  | PD2                                       | PD2                                    |

## 7.2.5.8 CAN alternate function remapping

### 7.2.5.8.1 CAN1 alternate function remapping

The CAN1 signal can be mapped to port A, port B or port D, as shown in the following Table. For port D, there is no remapping function on 48-pin and 64-pin packages (there are no PD0 and PD1 on these packages).

Table 7-18 CAN1 alternate function remapping

| Alternate function | CAN1_RMP[1:0] = 00 | CAN1_RMP[1:0] = 01 | CAN1_RMP[1:0] = 10 | CAN1_RMP[1:0] = 11 |
|--------------------|--------------------|--------------------|--------------------|--------------------|
| CAN1_RX            | PA11               | PD8                | PB8                | PD0                |
| CAN1_TX            | PA12               | PD9                | PB9                | PD1                |

### 7.2.5.8.2 CAN2 alternate function remapping

CAN2 signal can be mapped to port B or port D, as shown in the following Table.

Table 7-19 CAN2 alternate function remapping

| Alternate function | CAN2_RMP[1:0] = 00 | CAN2_RMP[1:0] = 01 | CAN2_RMP[1:0] = 11 |
|--------------------|--------------------|--------------------|--------------------|
| CAN2_RX            | PB12               | PB5                | PD10               |
| CAN2_TX            | PB13               | PB6                | PD11               |

### 7.2.5.9 DVP alternate function remapping

The mapping relationship of DVP signals is shown in the following Table.

Table 7-20 DVP alternate function remapping

| Alternate function | DVP_RMP[1:0] = 00 | DVP_RMP[1:0] = 01 | DVP_RMP[1:0] = 11 |
|--------------------|-------------------|-------------------|-------------------|
| DVP_HSYNC          | PA1               | PE2               | PE2               |
| DVP_VSYNC          | PA2               | PE3               | PE3               |
| DVP_PCLK           | PA3               | PE4               | PE4               |
| DVP_D0             | PA4               | PE5               | PE5               |
| DVP_D1             | PA5               | PE6               | PE6               |
| DVP_D2             | PA6               | PC0               | PC0               |
| DVP_D3             | PA7               | PB2               | PB2               |
| DVP_D4             | PC4               | PF12              | PB10              |
| DVP_D5             | PC5               | PF13              | PB11              |
| DVP_D6             | PB0               | PF14              | PF14              |
| DVP_D7             | PB1               | PF15              | PF15              |

### 7.2.5.10 USARTx alternate function remapping

#### 7.2.5.10.1 USART1 pin remapping

USART1/2/3 interfaces have remapping function. See the alternate remapping configuration register (AFIO\_RMP\_CFG).

Table 7-21 USART1 alternate function remapping

| Alternate function | USART1_RMP = 0 | USART1_RMP = 1 |
|--------------------|----------------|----------------|
| USART1_CTS         | PA11           |                |
| USART1_RTS         | PA12           |                |
| USART1_TX          | PA9            | PB6            |
| USART1_RX          | PA10           | PB7            |
| USART1_CK          | PA8            |                |

#### 7.2.5.10.2 USART2 pin remapping

Table 7-22 USART2 alternate function remapping

| Alternate function | USART2_RMP[1:0] = 00 | USART2_RMP[1:0] = 01 | USART2_RMP[1:0] = 10 | USART2_RMP [1:0] =11 |
|--------------------|----------------------|----------------------|----------------------|----------------------|
| USART2_CTS         | PA0                  | PD3                  | PC6                  | PA15                 |
| USART2_RTS         | PA1                  | PD4                  | PC7                  | PB3                  |
| USART2_TX          | PA2                  | PD5                  | PC8                  | PB4                  |
| USART2_RX          | PA3                  | PD6                  | PC9                  | PB5                  |
| USART2_CK          | PA4                  | PD7                  | /                    | PA4                  |

### 7.2.5.10.3 USART3 pin remapping

Table 7-23 USART3 alternate function remapping

| Alternate function | USART3_RMP[1:0] = 00 | USART3_RMP[1:0] = 01 | USART3_RMP[1:0] = 11 |
|--------------------|----------------------|----------------------|----------------------|
| USART3_TX          | PB10                 | PC10                 | PD8                  |
| USART3_RX          | PB11                 | PC11                 | PD9                  |
| USART3_CK          | PB12                 | PC12                 | PD10                 |
| USART3_CTS         | PB13                 |                      | PD11                 |
| USART3_RTS         | PB14                 |                      | PD12                 |

### 7.2.5.11 UARTx alternate function remapping

UART4/5/6/7 interfaces have remapping function. See the alternate remapping configuration register (AFIO\_RMP\_CFG3).

#### 7.2.5.11.1 UART4 pin remapping

Table 7-24 UART4 alternate function remapping

| Alternate function | UART4_RMP[1:0] = 00 | UART4_RMP[1:0] = 01 | UART4_RMP[1:0] = 10 | UART4_RMP [1:0] =11 |
|--------------------|---------------------|---------------------|---------------------|---------------------|
| UART4_TX           | PC10                | PB2                 | PA13                | PD0                 |
| UART4_RX           | PC11                | PE7                 | PA14                | PD1                 |

#### 7.2.5.11.2 UART5 pin remapping

Table 7-25 UART5 alternate function remapping

| Alternate function | UART5_RMP[1:0] = 00 | UART5_RMP[1:0] = 01 | UART5_RMP[1:0] = 10 | UART5_RMP [1:0] =11 |
|--------------------|---------------------|---------------------|---------------------|---------------------|
| UART5_TX           | PC12                | PB13                | PE8                 | PB8                 |
| UART5_RX           | PD2                 | PB14                | PE9                 | PB9                 |

#### 7.2.5.11.3 UART6 pin remapping

Table 7-26 UART6 alternate function remapping

| Alternate function | UART6_RMP[1:0] = 00 | UART6_RMP[1:0] = 10 | UART6_RMP[1:0] = 11 |
|--------------------|---------------------|---------------------|---------------------|
| UART6_TX           | PE2                 | PC0                 | PB0                 |
| UART6_RX           | PE3                 | PC1                 | PB1                 |

#### 7.2.5.11.4 UART7 pin remapping

Table 7-27 UART7 alternate function remapping

| Alternate function | UART7_RMP[1:0] = 00 | UART7_RMP[1:0] = 01 | UART7_RMP[1:0] = 11 |
|--------------------|---------------------|---------------------|---------------------|
| UART7_TX           | PC4                 | PC2                 | PG0                 |
| UART7_RX           | PC5                 | PC3                 | PG1                 |

### 7.2.5.12 I2C alternate function remapping

#### 7.2.5.12.1 I2C1 pin remapping

See alternate remapping configuration register (AFIO\_RMP\_CFG).

Table 7-28 I2C1 pin remapping

| Alternate function | I2C1_RMP= 0 | I2C1_RMP= 1 |
|--------------------|-------------|-------------|
| I2C1_SCL           | PB6         | PB8         |
| I2C1_SDA           | PB7         | PB9         |
| I2C1_SMBA          | PB5         |             |

### 7.2.5.12.2 I2C2 pin remapping

See alternate remapping configuration register (AFIO\_RMP\_CFG3).

Table 7-29 I2C2 pin remapping

| Alternate function | I2C2_RMP[1:0] = 00 | I2C2_RMP[1:0] = 01 | I2C2_RMP[1:0] = 11 |
|--------------------|--------------------|--------------------|--------------------|
| I2C2_SCL           | PB10               | PG2                | PA4                |
| I2C2_SDA           | PB11               | PG3                | PA5                |
| I2C2_SMBA          | PB12               |                    |                    |

### 7.2.5.12.3 I2C3 pin remapping

See alternate remapping configuration register (AFIO\_RMP\_CFG3).

Table 7-30 I2C3 pin remapping

| Alternate function | I2C3_RMP[1:0] = 00 | I2C3_RMP[1:0] = 10 | I2C3_RMP[1:0] = 11 |
|--------------------|--------------------|--------------------|--------------------|
| I2C3_SCL           | PC0                | PF4                | PC4                |
| I2C3_SDA           | PC1                | PF5                | PC5                |

### 7.2.5.12.4 I2C4 pin remapping

See alternate remapping configuration register (AFIO\_RMP\_CFG3).

Table 7-31 I2C4 pin remapping

| Alternate function | I2C4_RMP[1:0] = 00 | I2C4_RMP[1:0] = 01 | I2C4_RMP[1:0] = 11 |
|--------------------|--------------------|--------------------|--------------------|
| I2C4_SCL           | PC6                | PD14               | PA9                |
| I2C4_SDA           | PC7                | PD15               | PA10               |

## 7.2.5.13 SPI/I2S alternate function remapping

### 7.2.5.13.1 SPI1 pin remapping

See alternate remapping configuration register (AFIO\_RMP\_CFG).

Table 7-32 SPI1 pin remapping

| Alternate function | SPI1_RMP[1:0] = 00 | SPI1_RMP[1:0] = 01 | SPI1_RMP[1:0] = 10 | SPI1_RMP [1:0] =11 |
|--------------------|--------------------|--------------------|--------------------|--------------------|
| SPI1_NSS           | PA4                | PA15               | PB2                | PB2                |
| SPI1_SCK           | PA5                | PB3                | PA5                | PE7                |
| SPI1_MISO          | PA6                | PB4                | PA6                | PE8                |
| SPI1_MOSI          | PA7                | PB5                | PA7                | PE9                |

### 7.2.5.13.2 SPI2/I2S2 pin remapping

See alternate remapping configuration register (AFIO\_RMP\_CFG3).

Table 7-33 SPI2/I2S2 pin remapping

| Alternate function | SPI2_RMP[1:0] = 00 | SPI2_RMP[1:0] = 01 | SPI2_RMP[1:0] = 11 |
|--------------------|--------------------|--------------------|--------------------|
| SPI2_NSS/I2S2_WS   | PB12               | PC6                | PE10               |
| SPI2_SCK/I2S2_CK   | PB13               | PC7                | PE11               |
| SPI2_MISO          | PB14               | PC8                | PE12               |
| SPI2_MOSI/I2S2_SD  | PB15               | PC9                | PE13               |

### 7.2.5.13.3 SPI3/I2S3 pin remapping

See alternate remapping configuration register (AFIO\_RMP\_CFG3).

Table 7-34 SPI3/I2S3 pin remapping

| Alternate function | SPI3_RMP[1:0] = 00 | SPI3_RMP[1:0] = 01 | SPI3_RMP[1:0] = 10 | SPI3_RMP[1:0] = 11 |
|--------------------|--------------------|--------------------|--------------------|--------------------|
| SPI3_NSS/I2S3_WS   | PA15               | PD2                | PD8                | PC2                |
| SPI3_SCK/I2S3_CK   | PB3                | PC10               | PD9                | PC3                |
| SPI3_MISO          | PB4                | PC11               | PD11               | PA0                |
| SPI3_MOSI/I2S3_SD  | PB5                | PC12               | PD12               | PA1                |

### 7.2.5.14 SDIO alternate function remapping

See alternate remapping configuration register (AFIO\_RMP\_CFG3).

Table 7-35 SDIO pin remapping

| Alternate function | SDIO_RMP = 0 | SDIO_RMP = 1 |
|--------------------|--------------|--------------|
| SDIO_0             | PC8          | PE8          |
| SDIO_1             | PC9          | PE9          |
| SDIO_2             | PC10         | PE10         |
| SDIO_3             | PC11         | PE11         |
| SDIO_4             | PB8          |              |
| SDIO_5             | PB9          |              |
| SDIO_6             | PC6          |              |
| SDIO_7             | PC7          |              |
| SDIO_CK            | PC12         | PE12         |
| SDIO_CMD           | PD2          | PE13         |

### 7.2.5.15 QSPI alternate function remapping

QSPI only supports master mode, and does not support multi-master mode. In single-line mode, QSPI\_IO1 acts as MISO, supports push-pull alternate output, input floating or input pull-up. See alternate remapping configuration register (AFIO\_RMP\_CFG3).

Table 7-36 QSPI pin remapping

| Alternate function | QSPI_RMP[1:0] = 00 | QSPI_RMP[1:0] = 01 | QSPI_RMP[1:0] = 11 |
|--------------------|--------------------|--------------------|--------------------|
| QSPI_NSS           | PA4                | PF0                | PC10               |
| QSPI_CLK           | PA5                | PF1                | PC11               |
| QSPI_IO0           | PA6                | PF2                | PC12               |
| QSPI_IO1           | PA7                | PF3                | PD0                |

| Alternate function | QSPI_RMP[1:0] = 00 | QSPI_RMP[1:0] = 01 | QSPI_RMP[1:0] = 11 |
|--------------------|--------------------|--------------------|--------------------|
| QSPI_IO2           | PC4                | PF4                | PD1                |
| QSPI_IO3           | PC5                | PF5                | PD2                |

### 7.2.5.16 ETH alternate function remapping

See alternate remapping configuration register (AFIO\_RMP\_CFG).

Table 7-37 ETH pin remapping

| Alternate function                  | ETH_RMP[1:0] = 00 | ETH_RMP[1:0] = 01 | ETH_RMP[1:0] = 10 | ETH_RMP[1:0] = 11 |
|-------------------------------------|-------------------|-------------------|-------------------|-------------------|
| ETH_MII_MDC<br>ETH_RMII_MDC         | PC1               |                   |                   |                   |
| ETH_MII_TX2                         | PC2               |                   |                   |                   |
| ETH_MII_TX_CLK                      | PC3               |                   |                   |                   |
| ETH_MII_CRD_WKUP                    | PA0               |                   |                   |                   |
| ETH_MII_RX_CLK<br>ETH_RMII_REF_CLK  | PA1               |                   |                   |                   |
| ETH_MII_MDIO<br>ETH_RMII_MDIO       | PA2               |                   |                   |                   |
| ETH_MII_COL                         | PA3               |                   |                   |                   |
| ETH_MII_RX_DV<br>ETH_RMII_CRD_DV    | PA7               | PD8               | PA7               | PD8               |
| ETH_MII_RXD0<br>ETH_RMII_RXD0       | PC4               | PD9               | PC4               | PD9               |
| ETH_MII_RXD1<br>ETH_RMII_RXD1       | PC5               | PD10              | PC5               | PD10              |
| ETH_MII_RXD2                        | PB0               | PD11              | PB0               | PB0               |
| ETH_MII_RXD3                        | PB1               | PD12              | PB1               | PB1               |
| ETH_MII_RX_ER                       | PB10              |                   |                   |                   |
| Ethernet<br>Ethernet                | PB11              |                   |                   |                   |
| ETH_MII_TXD0<br>ETH_RMII_TXD0       | PB12              |                   |                   |                   |
| ETH_MII_TXD1<br>ETH_RMII_TXD1       | PB13              |                   |                   |                   |
| ETH_MII_PPS_OUT<br>ETH_RMII_PPS_OUT | PB5               |                   | PB6               |                   |
| ETH_MII_TXD3                        | PB8               |                   | PB7               |                   |

## 7.2.6 I/O configuration of peripherals

Table 7-38 ADC/DAC

| ADC/DAC pin | GPIO configuration |
|-------------|--------------------|
|-------------|--------------------|

|     |             |
|-----|-------------|
| ADC | Analog mode |
| DAC | Analog mode |

Table 7-39 TIM1/TIM8

| TIM1/TIM8 pin | Configuration                  | PAD configuration mode     |
|---------------|--------------------------------|----------------------------|
| TIM1/8_CHx    | Input capture channel x        | Input floating             |
|               | Output channel x               | Push-pull alternate output |
| TIM1/8_CHxN   | Complementary output channel x | Push-pull alternate output |
| TIM1/8_BKIN   | Brake input                    | Input floating             |
| TIM1/8_ETR    | External trigger clock input   | Input floating             |

Table 7-40 TIM2/3/4/5

| TIM2/3/4/5 pin | Configuration                | PAD configuration mode     |
|----------------|------------------------------|----------------------------|
| TIM2/3/4/5_CHx | Input capture channel x      | Input floating             |
|                | Output channel x             | Push-pull alternate output |
| TIM2/3/4/5_ETR | External trigger clock input | Input floating             |

Table 7-41 bxCAN

| bxCAN pin | GPIO configuration              |
|-----------|---------------------------------|
| CAN_TX    | Push-pull alternate output      |
| CAN_RX    | Input floating or input pull-up |

Table 7-42 DVP

| DVP pin   | GPIO configuration |
|-----------|--------------------|
| DVP_HSYNC | Input floating     |
| DVP_VSYNC | Input floating     |
| DVP_PCLK  | Input floating     |
| DVP_D0    | Input floating     |
| DVP_D1    | Input floating     |
| DVP_D2    | Input floating     |
| DVP_D3    | Input floating     |
| DVP_D4    | Input floating     |
| DVP_D5    | Input floating     |
| DVP_D6    | Input floating     |

| DVP pin | GPIO configuration |
|---------|--------------------|
| DVP_D7  | Input floating     |

Table 7-43 USART

| USART pin  | Configuration                | GPIO configuration                     |
|------------|------------------------------|--|
| USARTx_TX  | full duplex transmissions    | Push-pull alternate output             |
|            | Half duplex synchronous mode | Push-pull alternate output and pull-up |
| USARTx_RX  | full duplex transmissions    | input pull-up                          |
|            | Half duplex synchronous mode | Unused, can be used as general I/O.    |
| USARTx_CK  | Synchronous mode             | Push-pull alternate output             |
| USARTx_RTS | Hardware flow control        | Push-pull alternate output             |
| USARTx_CTS | Hardware flow control        | Input floating or input pull-up        |

Table 7-44 I2C

| I2C pin   | Description | GPIO configuration          |
|-----------|-------------|-----------------------------|
| I2Cx_SCL  | I2C clock   | Open-drain alternate output |
| I2Cx_SDA  | I2C data    | Open-drain alternate output |
| I2Cx_SMBA | SMBA data   | Push-pull alternate output  |

Table 7-45 SPI

| SPI pin   | Description                                 | GPIO configuration  |
|-----------|---|---|
| SPIx_SCK  | Master mode                                 | Push-pull alternate output                                    |
|           | Slave mode                                  | Input floating  |
| SPIx_MOSI | Full duplex mode/ Master mode               | Push-pull alternate output                                    |
|           | Full duplex mode/slave mode                 | Floating input or input pull-up or push-pull alternate output |
|           | Simple bidirectional data line/ Master mode | Push-pull alternate output                                    |
|           | Simple bidirectional data line/slave mode   | Unused, can be used as general I/O.                           |
| SPIx_MISO | Full duplex mode/ Master mode               | Floating input or input pull-up or push-pull alternate output |
|           | Full duplex mode/slave mode                 | Push-pull alternate output                                    |
|           | Simple bidirectional data line/ Master mode | Unused, can be used as general I/O.                           |

| SPI pin  | Description                               | GPIO configuration  |
|----------|---|---|
|          | Simple bidirectional data line/slave mode | Push-pull alternate output  |
| SPIx_NSS | Hardware master/slave mode                | Input floating or pull-up input or input pull-down  |
|          | Hardware mode /NSS output enable          | Push-pull alternate output (NSS can choose idle high resistance or idle is 1 when it is the master) |
|          | Software mode                             | Unused, can be used as general I/O.   |

Table 7-46 I2S

| I2S pin  | Configuration | GPIO configuration                                 |
|----------|---------------|--|
| I2Sx_WS  | Master mode   | Push-pull alternate output                         |
|          | Slave mode    | Floating input                                     |
| I2Sx_CK  | Master mode   | Push-pull alternate output                         |
|          | Slave mode    | Input floating                                     |
| I2Sx_SD  | transmitter   | Push-pull alternate output                         |
|          | receiver      | Input floating or pull-up input or input pull-down |
| I2Sx_MCK | Master mode   | Push-pull alternate output                         |
|          | Slave mode    | Unused, can be used as general I/O.                |

Table 7-47 SDIO

| SDIO pin    | GPIO configuration         |
|-------------|----------------------------|
| SDIO_CK     | Push-pull alternate output |
| SDIO_CMD    | Push-pull alternate output |
| SDIO[D7:D0] | Push-pull alternate output |

Table 7-48 QSPI

| QSPI pin | GPIO configuration         | remarks   |
|----------|----------------------------|---|
| QSPI_IO3 | Push-pull alternate output | QSPI only supports master mode, and does not support multi-master mode. |
| QSPI_IO2 | Push-pull alternate output |   |
| QSPI_IO1 | Push-pull alternate output |   |
| QSPI_IO0 | Push-pull alternate output |   |
| QSPI_CLK | Push-pull alternate output |   |
| QSPI_NSS | Push-pull alternate        |   |

| QSPI pin | GPIO configuration | remarks |
|----------|--------------------|---------|
|          | output             |         |

Table 7-49 ETH

| MAC signal                         | Pin configuration                              |
|------------------------------------|--|
| ETH_MDC                            | Push-pull alternate output, high speed (50MHz) |
| ETH_MII_TXD2                       | Push-pull alternate output                     |
| ETH_MII_TX_CLK                     | Input floating (reset state)                   |
| ETH_MII_CRS                        | Input floating (reset state)                   |
| ETH_MII_RX_CLK<br>ETH_RMII_REF_CLK | Input floating (reset state)                   |
| ETH_MDIO                           | Push-pull alternate output, high speed (50MHz) |
| ETH_MII_COL                        | Input floating (reset state)                   |
| ETH_MII_RX_DV<br>ETH_RMII_CRS_DV   | Input floating (reset state)                   |
| ETH_MII_RXD0<br>ETH_RMII_RXD0      | Input floating (reset state)                   |
| ETH_MII_RXD1<br>ETH_RMII_RXD1      | Input floating (reset state)                   |
| ETH_MII_RXD2                       | Input floating (reset state)                   |
| ETH_MII_RXD3                       | Input floating (reset state)                   |
| ETH MII RX ER                      | Input floating (reset state)                   |
| Ethernet<br>Ethernet               | Push-pull alternate output, high speed (50MHz) |
| ETH_MII_TXD0<br>ETH_RMII_TXD0      | Push-pull alternate output, high speed (50MHz) |
| ETH_MII_TXD1<br>ETH_RMII_TXD1      | Push-pull alternate output, high speed (50MHz) |
| ETH_PPS_OUT                        | Push-pull alternate output, high speed (50MHz) |
| ETH_MII_TXD3                       | Push-pull alternate output, high speed (50MHz) |
| ETH_RMII_CRS_DV                    | Input floating (reset state)                   |
| ETH_MII_RXD0<br>ETH_RMII_RXD0      | Input floating (reset state)                   |
| ETH_MII_RXD1<br>ETH_RMII_RXD1      | Input floating (reset state)                   |
| ETH_MII_RXD2                       | Input floating (reset state)                   |
| ETH_MII_RXD3                       | Input floating (reset state)                   |

Table 7-50 USB

| USB pin          | GPIO configuration  |
|------------------|---|
| USB_DM<br>USB_DP | Once the USB module is enabled, these pins are automatically connected to the internal USB transceiver. |

Table 7-51 Other

| pin             | Alternate function       | GPIO configuration   |
|-----------------|--------------------------|--|
| TAMPER-RTC      | RTC output               | When configuring BKP_CR and BKP_RTCCR registers, it is forced by hardware. |
|                 | Intrusion event input    |  |
| MCO             | Clock output             | Push-pull alternate output   |
| EXTI input line | External interrupt input | Input floating or pull-up input or input pull-down                         |

## 7.2.7 GPIO locking mechanism

The locking mechanism is used to freeze the I/O configuration to prevent accidental changes. When a LOCK program is executed on a port bit, the port configuration cannot be changed until the next reset. Refer to the port configuration lock register GPIOx\_PLOCK\_CFG.

- PLOCKK\_CFG is GPIOx\_PLOCK\_CFG[16], which will become 1 only after the PLOCKK\_CFG is operated according to the correct sequence w1->w0->w1->r0 (where r0 is required); After that, it will become 0 only after system reset.
- PLOCK\_CFGy is GPIOx\_PLOCK\_CFG [15:0], which can only be modified when PLOCKK\_CFG = 0, that is, it is unlocked.
- The sequence w1->w0->w1->r0 is valid only when the PLOCKK\_CFG is written at the same time as the non-zero GPIOx\_PLOCKK\_CFG [15: 0]. GPIOx\_PLOCK\_CFG [15:0] must not be changed during sequence writing;
- GPIOx\_PH\_CFG/GPIOx\_PL\_CFG bits can be modified as long as PLOCK\_CFG = 0, which is not affected by the configuration of GPIOx\_PLOCK\_CFG [15:0].
- PLOCKK\_CFG=1, GPIOx\_PH\_CFG/GPIOx\_PL\_CFG is controlled by GPIOx\_PLOCK\_CFG [15:0], corresponding to PLOCK\_CFGy (y = 0...15) =1 which is a locked configuration and cannot be modified, and PLOCK\_CFGy=0, can be modified.
- If the sequence operation is wrong, w1->w0->w1->r0 must be performed again to initiate the locking operation again.

## 7.3 GPIO registers

These peripheral registers must be operated as 32-bit words.

### 7.3.1 GPIO register overview

GPIOA base address: 0x40010800

GPIOB base address: 0x40010C00

GPIOC base address: 0x40011000

GPIOD base address: 0x40011400

GPIOE base address: 0x40011800

GPIOF base address: 0x40011C00

GPIOG base address: 0x40012000

Table 7-52 GPIO registers overview

| Offset | Register        | 31          | 30    | 29           | 28    | 27          | 26    | 25           | 24   | 23          | 22   | 21           | 20   | 19          | 18   | 17           | 16   | 15          | 14 | 13           | 12          | 11          | 10          | 9            | 8           | 7           | 6          | 5           | 4          | 3          | 2          | 1           | 0          |            |            |            |
|--------|-----------------|-------------|-------|--------------|-------|-------------|-------|--------------|------|-------------|------|--------------|------|-------------|------|--------------|------|-------------|----|--------------|-------------|-------------|-------------|--------------|-------------|-------------|------------|-------------|------------|------------|------------|-------------|------------|------------|------------|------------|
| 000h   | GPIOx_PL_CFG    | PCFG7[1:0]  |       | PMODE7[1:0]  |       | PCFG6[1:0]  |       | PMODE6[1:0]  |      | PCFG5[1:0]  |      | PMODE5[1:0]  |      | PCFG4[1:0]  |      | PMODE4[1:0]  |      | PCFG3[1:0]  |    | PMODE3[1:0]  |             | PCFG2[1:0]  |             | PMODE2[1:0]  |             | PCFG1[1:0]  |            | PMODE1[1:0] |            | PCFG0[1:0] |            | PMODE0[1:0] |            |            |            |            |
|        | Reset Value     | x=B<br>0 0  |       | 0 0          |       | 0 0         |       | 0 0          |      | 0 0         |      | 0 0          |      | 1 0         |      | 0 0          |      | 0 0         |    | 0 0          |             | 1 0         |             | 0 0          |             | 0 0         |            | 0 0         |            | 0 0        |            | 0 0         |            |            |            |            |
| 004h   | GPIOx_PH_CFG    | PCFG15[1:0] |       | PMODE15[1:0] |       | PCFG14[1:0] |       | PMODE14[1:0] |      | PCFG13[1:0] |      | PMODE13[1:0] |      | PCFG12[1:0] |      | PMODE12[1:0] |      | PCFG11[1:0] |    | PMODE11[1:0] |             | PCFG10[1:0] |             | PMODE10[1:0] |             | PCFG9[1:0]  |            | PMODE9[1:0] |            | PCFG8[1:0] |            | PMODE8[1:0] |            |            |            |            |
|        | Reset Value     | x=A<br>1 0  |       | 0 0          |       | 1 0         |       | 0 0          |      | 1 0         |      | 0 0          |      | 0 0         |      | 0 0          |      | 0 0         |    | 0 0          |             | 0 0         |             | 0 0          |             | 0 0         |            | 0 0         |            | 0 0        |            | 0 0         |            |            |            |            |
| 008h   | GPIOx_PID       | Reserved    |       |              |       |             |       |              |      |             |      |              |      |             |      |              |      |             |    | PID15        | PID14       | PID13       | PID12       | PID11        | PID10       | PID9        | PID8       | PID7        | PID6       | PID5       | PID4       | PID3        | PID2       | PID1       | PID0       |            |
|        | Reset Value     | 0           |       |              |       |             |       |              |      |             |      |              |      |             |      |              |      |             |    | 0            | 0           | 0           | 0           | 0            | 0           | 0           | 0          | 0           | 0          | 0          | 0          | 0           | 0          | 0          | 0          |            |
| 00Ch   | GPIOx_POD       | Reserved    |       |              |       |             |       |              |      |             |      |              |      |             |      |              |      |             |    | POD15        | POD14       | POD13       | POD12       | POD11        | POD10       | POD9        | POD8       | POD7        | POD6       | POD5       | POD4       | POD3        | POD2       | POD1       | POD0       |            |
|        | Reset Value     | 0           |       |              |       |             |       |              |      |             |      |              |      |             |      |              |      |             |    | 1            | 0           | 1           | 0           | 0            | 0           | 0           | 0          | 0           | 0          | 0          | 0          | 0           | 0          | 0          | 0          |            |
|        | x=A             | 0           |       |              |       |             |       |              |      |             |      |              |      |             |      |              |      |             |    | 0            | 0           | 0           | 0           | 0            | 0           | 0           | 0          | 0           | 0          | 0          | 0          | 0           | 0          | 0          | 0          |            |
|        | x=B             | 0           |       |              |       |             |       |              |      |             |      |              |      |             |      |              |      |             |    | 0            | 0           | 0           | 0           | 0            | 0           | 0           | 0          | 0           | 0          | 0          | 0          | 0           | 0          | 0          | 0          |            |
| 010h   | GPIOx_PBSC      | PBC15       | PBC14 | PBC13        | PBC12 | PBC11       | PBC10 | PBC9         | PBC8 | PBC7        | PBC6 | PBC5         | PBC4 | PBC3        | PBC2 | PBC1         | PBC0 |             |    |              |             |             |             |              |             |             |            |             |            |            |            |             |            |            |            |            |
|        | Reset Value     | 0           | 0     | 0            | 0     | 0           | 0     | 0            | 0    | 0           | 0    | 0            | 0    | 0           | 0    | 0            | 0    |             |    |              |             |             |             |              |             |             |            |             |            |            |            |             |            |            |            |            |
| 014h   | GPIOx_PBC       | Reserved    |       |              |       |             |       |              |      |             |      |              |      |             |      |              |      |             |    | PBC15        | PBC14       | PBC13       | PBC12       | PBC11        | PBC10       | PBC9        | PBC8       | PBC7        | PBC6       | PBC5       | PBC4       | PBC3        | PBC2       | PBC1       | PBC0       |            |
|        | Reset Value     | 0           |       |              |       |             |       |              |      |             |      |              |      |             |      |              |      |             |    | 0            | 0           | 0           | 0           | 0            | 0           | 0           | 0          | 0           | 0          | 0          | 0          | 0           | 0          | 0          | 0          |            |
| 018h   | GPIOx_PLOCK_CFG | Reserved    |       |              |       |             |       |              |      |             |      |              |      |             |      |              |      |             |    | PLOCKK_CFG   | PLOCK_CFG15 | PLOCK_CFG14 | PLOCK_CFG13 | PLOCK_CFG12  | PLOCK_CFG11 | PLOCK_CFG10 | PLOCK_CFG9 | PLOCK_CFG8  | PLOCK_CFG7 | PLOCK_CFG6 | PLOCK_CFG5 | PLOCK_CFG4  | PLOCK_CFG3 | PLOCK_CFG2 | PLOCK_CFG1 | PLOCK_CFG0 |
|        | Reset Value     | 0           |       |              |       |             |       |              |      |             |      |              |      |             |      |              |      |             |    | 0            | 0           | 0           | 0           | 0            | 0           | 0           | 0          | 0           | 0          | 0          | 0          | 0           | 0          | 0          | 0          |            |
| 01Ch   | Reserved        |             |       |              |       |             |       |              |      |             |      |              |      |             |      |              |      |             |    |              |             |             |             |              |             |             |            |             |            |            |            |             |            |            |            |            |
| 020h   | GPIOx_DS_CFG    | Reserved    |       |              |       |             |       |              |      |             |      |              |      |             |      |              |      |             |    | DS_CFG15     | DS_CFG14    | DS_CFG13    | DS_CFG12    | DS_CFG11     | DS_CFG10    | DS_CFG9     | DS_CFG8    | DS_CFG7     | DS_CFG6    | DS_CFG5    | DS_CFG4    | DS_CFG3     | DS_CFG2    | DS_CFG1    | DS_CFG0    |            |
|        | Reset Value     | 0           |       |              |       |             |       |              |      |             |      |              |      |             |      |              |      |             |    | 1            | 1           | 1           | 1           | 0            | 0           | 0           | 0          | 0           | 0          | 1          | 1          | 1           | 1          | 1          | 1          |            |
|        | x=F             | 0           |       |              |       |             |       |              |      |             |      |              |      |             |      |              |      |             |    | 1            | 1           | 1           | 1           | 0            | 0           | 0           | 0          | 0           | 0          | 1          | 1          | 1           | 1          | 1          | 1          |            |
|        | x=G             | 0           |       |              |       |             |       |              |      |             |      |              |      |             |      |              |      |             |    | 1            | 1           | 1           | 1           | 0            | 0           | 0           | 0          | 0           | 0          | 1          | 1          | 1           | 1          | 1          | 1          |            |
| 024h   | GPIOx_SR_CFG    | Reserved    |       |              |       |             |       |              |      |             |      |              |      |             |      |              |      |             |    | SR_CFG15     | SR_CFG14    | SR_CFG13    | SR_CFG12    | SR_CFG11     | SR_CFG10    | SR_CFG9     | SR_CFG8    | SR_CFG7     | SR_CFG6    | SR_CFG5    | SR_CFG4    | SR_CFG3     | SR_CFG2    | SR_CFG1    | SR_CFG0    |            |
|        | Reset Value     | 0           |       |              |       |             |       |              |      |             |      |              |      |             |      |              |      |             |    | 0            | 0           | 0           | 0           | 0            | 0           | 1           | 0          | 0           | 0          | 1          | 1          | 1           | 1          | 1          | 1          |            |
|        | x=F             | 0           |       |              |       |             |       |              |      |             |      |              |      |             |      |              |      |             |    | 0            | 0           | 0           | 0           | 0            | 0           | 1           | 0          | 0           | 0          | 1          | 1          | 1           | 1          | 1          | 1          |            |
|        | x=G             | 0           |       |              |       |             |       |              |      |             |      |              |      |             |      |              |      |             |    | 0            | 0           | 0           | 0           | 0            | 0           | 1           | 0          | 0           | 0          | 1          | 1          | 1           | 1          | 1          | 1          |            |
| 024h   | GPIOx_SR_CFG    | Reserved    |       |              |       |             |       |              |      |             |      |              |      |             |      |              |      |             |    | SR_CFG15     | SR_CFG14    | SR_CFG13    | SR_CFG12    | SR_CFG11     | SR_CFG10    | SR_CFG9     | SR_CFG8    | SR_CFG7     | SR_CFG6    | SR_CFG5    | SR_CFG4    | SR_CFG3     | SR_CFG2    | SR_CFG1    | SR_CFG0    |            |
|        | Reset Value     | 0           |       |              |       |             |       |              |      |             |      |              |      |             |      |              |      |             |    | 0            | 0           | 0           | 0           | 0            | 0           | 0           | 0          | 0           | 0          | 0          | 0          | 0           | 0          | 0          | 0          |            |

### 7.3.2 GPIO port low configuration register (GPIOx\_PL\_CFG)

Address offset: 0x00

Reset value: 0x0000 0000 (x=A, C, D, E, F, G); 0x0008 0800 (x=B)

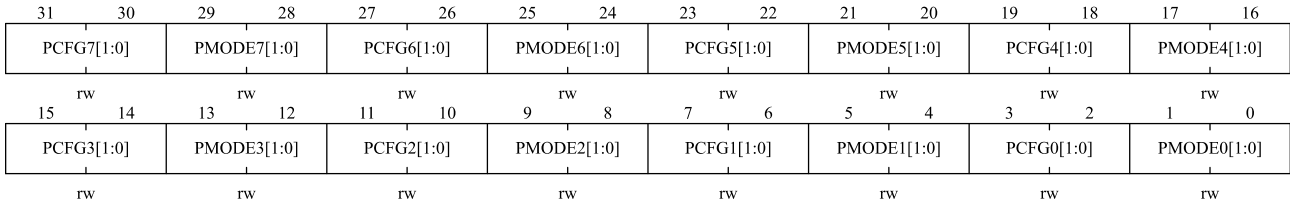

| Bit field  | Name        | Description  |
|--|-------------|--|
| 31:30<br>27:26<br>23:22<br>19:18<br>15:14<br>11:10<br>7:6<br>3:2 | PCFGy[1:0]  | Port x configuration bit (y = 0...7)<br><br>PMODE[1:0]=00 input mode:<br>00: analog function mode (state after reset)<br>01: Input floating mode<br><br>10: input pull-up/ input pull-down mode (note: when configuring the input pull-up/ input pull-down mode, you need to set/reset the corresponding GPIOx_POD register)<br>11: reserved<br><br>When PMODE[1:0]>00 output mode:<br>00: General push-pull output mode<br>01: General open-drain output mode<br>10: Alternate function push-pull output mode<br>11: Open-drain output mode of alternate function |
| 29:28<br>25:24<br>21:20<br>17:16<br>13:12<br>9:8<br>5:4<br>1:0   | PMODEy[1:0] | Mode bit of port x (y = 0...7)<br>00: input mode (state after reset)<br>01: output mode, maximum speed 2MHz<br>10: output mode, maximum speed 10MHz<br>11: output mode, maximum speed 50MHz  |

### 7.3.3 GPIO port high configuration register (GPIOx\_PH\_CFG)

Address offset: 0x04

Reset value: 0x8880 0000(x=A); 0x0000 0000(x=B,C,D,E,F,G)

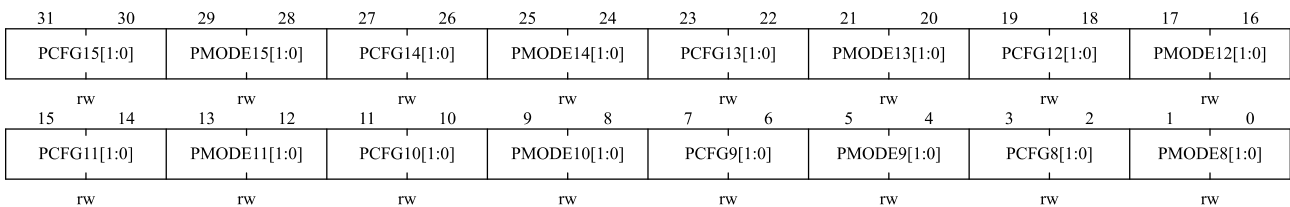

| Bit field                        | Name       | Description  |
|----------------------------------|------------|--|
| 31:30<br>27:26<br>23:22<br>19:18 | PCFGy[1:0] | Port x configuration bit (y = 8...15)<br><br>PMODE[1:0]=00 In input mode:<br>00: analog function mode (state after reset)<br>01: Input floating mode |

| Bit field  | Name        | Description   |
|--|-------------|---|
| 15:14<br>11:10<br>7:6<br>3:2                                   |             | 10: input pull-up/ input pull-down mode (note: when configuring the input pull-up/ input pull-down mode, you need to set/reset the corresponding GPIOx_POD register)<br>11: reserved<br>When MODE[1:0]>00 output mode:<br>00: General push-pull output mode<br>01: General open-drain output mode<br>10: Alternate function push-pull output mode<br>11: Open-drain output mode of alternate function |
| 29:28<br>25:24<br>21:20<br>17:16<br>13:12<br>9:8<br>5:4<br>1:0 | PMODEy[1:0] | Mode bit of port x (y = 8...15)<br>00: input mode (state after reset)<br>01: output mode, maximum speed 2MHz<br>10: output mode, maximum speed 10MHz<br>11: output mode, maximum speed 50MHz  |

### 7.3.4 GPIO port input data register (GPIOx\_PID)

Address offset: 0x08

Reset value: 0x0000 0000

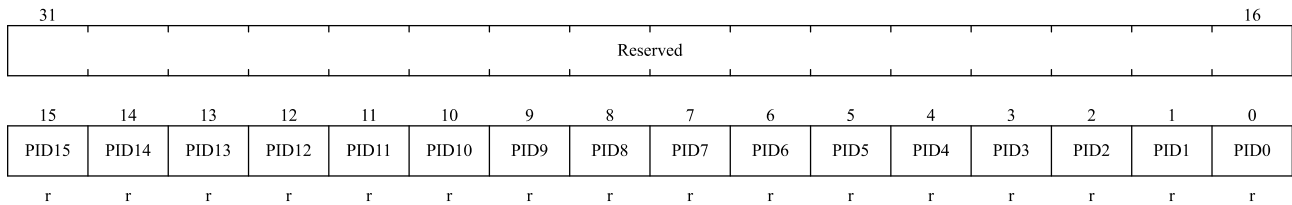

| Bit field | Name     | Description   |
|-----------|----------|---|
| 31:16     | Reserved | Reserved, the reset value must be maintained.   |
| 15:0      | PIDy     | Port input data (y = 0...15)<br>These bits are read-only and can only be read in the form of 16-bit words, and the read value is the state of the corresponding I/O port. |

### 7.3.5 GPIO port output data register (GPIOx\_POD)

Address offset: 0x0C

Reset value: 0x0000 A000(x=A); 0x0000 0010(x=B); 0x0000 0000(x=C,D,E,F,G)

|          |       |       |       |       |       |      |      |      |      |      |      |      |      |      |      |    |
|----------|-------|-------|-------|-------|-------|------|------|------|------|------|------|------|------|------|------|----|
| Reserved |       |       |       |       |       |      |      |      |      |      |      |      |      |      |      |    |
| 31       |       |       |       |       |       |      |      |      |      |      |      |      |      |      |      | 16 |
| 15       | 14    | 13    | 12    | 11    | 10    | 9    | 8    | 7    | 6    | 5    | 4    | 3    | 2    | 1    | 0    |    |
| POD15    | POD14 | POD13 | POD12 | POD11 | POD10 | POD9 | POD8 | POD7 | POD6 | POD5 | POD4 | POD3 | POD2 | POD1 | POD0 |    |
| rw       | rw    | rw    | rw    | rw    | rw    | rw   | rw   | rw   | rw   | rw   | rw   | rw   | rw   | rw   | rw   |    |

| Bit field | Name     | Description  |
|-----------|----------|--|
| 31:16     | Reserved | Reserved, the reset value must be maintained.  |
| 15:0      | PODy     | Port output data ( $y = 0 \dots 15$ )<br>These bits can only be read or written in the form of 16-bit words. GPIOx_PBSC( $x = A \dots G$ ) can be independently set/cleared for the corresponding POD bit. |

### 7.3.6 GPIO port bit setting/clearing register (GPIOx\_PBSC)

Address offset: 0x10

Reset value: 0x0000 0000

|       |       |       |       |       |       |      |      |      |      |      |      |      |      |      |      |
|-------|-------|-------|-------|-------|-------|------|------|------|------|------|------|------|------|------|------|
| 31    | 30    | 29    | 28    | 27    | 26    | 25   | 24   | 23   | 22   | 21   | 20   | 19   | 18   | 17   | 16   |
| PBC15 | PBC14 | PBC13 | PBC12 | PBC11 | PBC10 | PBC9 | PBC8 | PBC7 | PBC6 | PBC5 | PBC4 | PBC3 | PBC2 | PBC1 | PBC0 |
| w     | w     | w     | w     | w     | w     | w    | w    | w    | w    | w    | w    | w    | w    | w    | w    |
| 15    | 14    | 13    | 12    | 11    | 10    | 9    | 8    | 7    | 6    | 5    | 4    | 3    | 2    | 1    | 0    |
| PBS15 | PBS14 | PBS13 | PBS12 | PBS11 | PBS10 | PBS9 | PBS8 | PBS7 | PBS6 | PBS5 | PBS4 | PBS3 | PBS2 | PBS1 | PBS0 |
| w     | w     | w     | w     | w     | w     | w    | w    | w    | w    | w    | w    | w    | w    | w    | w    |

| Bit field | Name | Description   |
|-----------|------|---|
| 31:16     | PBCy | Clear bit $y$ of port GPIOx ( $y = 0 \dots 15$ )<br>These bits can only be written and operated as words (16 bits).<br>0: does not affect the corresponding PODy bit<br>1: Clear the corresponding PODy bit to 0<br><i>Note: if the corresponding bits of PBSy and PBCy are set at the same time, the PBSy bit works.</i> |
| 15:0      | PBSy | Set bit $y$ of port GPIOx ( $y = 0 \dots 15$ )<br>These bits can only be written and operated as words (16 bits).<br>0: does not affect the corresponding PODy bit<br>1: Set the corresponding PODy bit to 1  |

### 7.3.7 GPIO port bit clear register (GPIOx\_PBC)

Address offset: 0x14

Reset value: 0x0000 0000

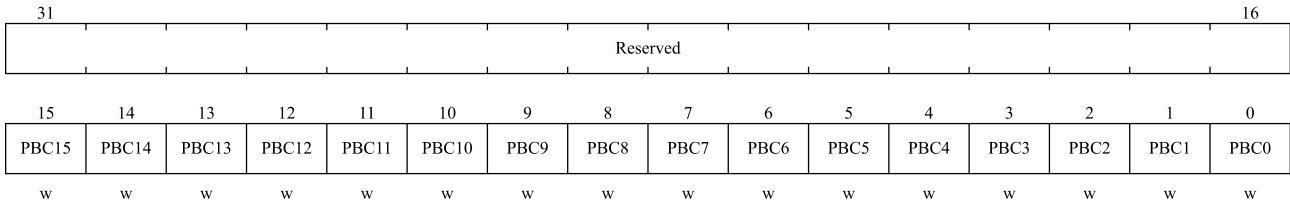

| Bit field | Name     | Description  |
|-----------|----------|--|
| 31:16     | Reserved | Reserved, the reset value must be maintained.  |
| 15:0      | PBCy     | Clear bit y of port GPIOx (y = 0...15)<br>These bits can only be written and operated as words (16 bits).<br>0: does not affect the corresponding PODy bit<br>1: Clear the corresponding PODy bit to 0 |

### 7.3.8 GPIO port lock configuration register (GPIOx\_PLOCK\_CFG )

Address offset: 0x18

Reset value: 0x0000 0000

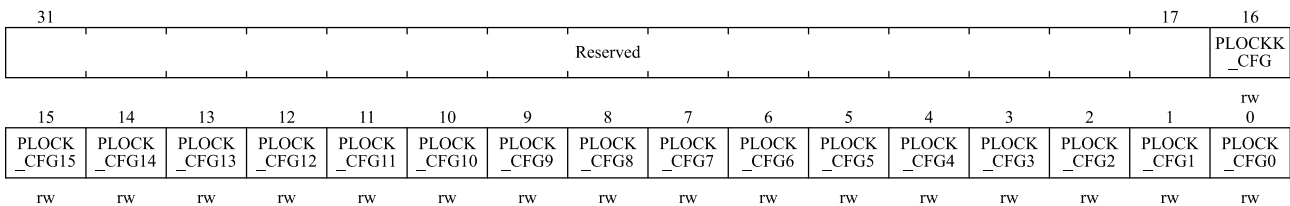

| Bit field | Name       | Description   |
|-----------|------------|---|
| 31:17     | Reserved   | Reserved, the reset value must be maintained.   |
| 16        | PLOCKK_CFG | Lock key. This bit can be read at any time, and it can only be modified by the key lock write sequence.<br>0: Port configuration lock key is activated<br>1: The port configuration lock key is activated, and the GPIOx_PLOCK_CFG register is locked before the next system reset. The write sequence of the lock key:<br>Write 1 -> write 0 -> write 1 -> read 0 -> read 1<br>The last reading can be omitted, but it can be used to confirm that the lock key has been activated.<br><i>Note: the value of PLOCK_CFG[15:0] cannot be changed when the writing sequence of lock key is operated. Any error in the operation key writing sequence will not activate the key.</i> |
| 15:0      | PLOCK_CFGy | Configuration lock bit y of port GPIOx (y = 0...15)<br>These bits are readable and writable but can only be written when the PLOCKK_CFG bit is 0.<br>0: Do not lock the configuration of the port<br>1: Lock the configuration of the port  |

### 7.3.9 GPIO driver capability configuration register (GPIOx\_DS\_CFG)

Address offset: 0x20

Reset value: 0x0000 FFFF (x = A,B,C,D,E) ; 0x0000 F03F (x=F) ; 0x0000 023F (x=G)

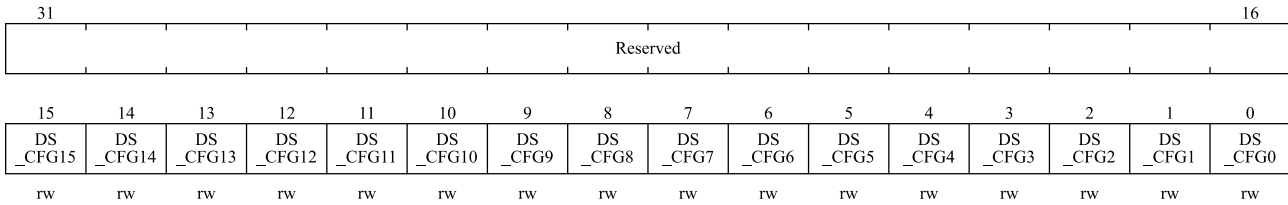

| Bit field | Name     | Description  |
|-----------|----------|--|
| 31:16     | Reserved | Reserved, the reset value must be maintained.  |
| 15:0      | DS_CFGy  | The drive capability configuration bit y of port GPIOx (y = 0...15)<br>These bits can only be read or written in the form of 16-bit words.<br>0: 2mA<br>1: Controlled by PMODEy of GPIOx_PH_CFG/GPIOx_PL_CFG.<br>PMODE: 00/01, 8mA;<br>PMODEy: 10, 4mA;<br>PMODEy: 11, 12mA. |

### 7.3.10 GPIO flip rate configuration register (GPIOx\_SR\_CFG)

Address offset: 0x24

Reset value: 0x0000 FFFF (x= A,B,C,D,E); 0x0000 F03F (x=F); 0x0000 023F (x=G)

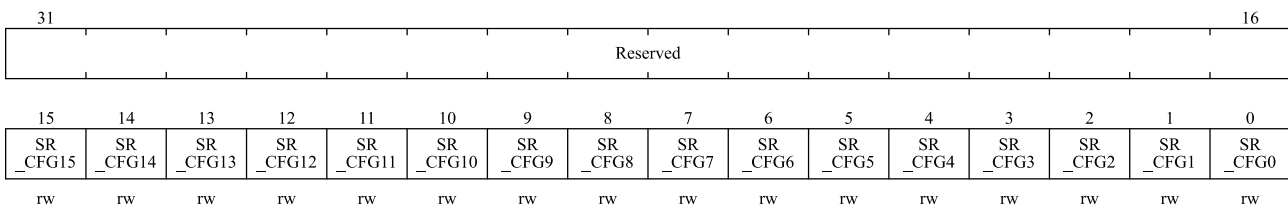

| Bit field | Name     | Description  |
|-----------|----------|--|
| 31:16     | Reserved | Reserved, the reset value must be maintained.  |
| 15:0      | SR_CFGy  | Port GPIOx flip rate configuration bit y (y = 0...15)<br>These bits can only be read or written in the form of 16-bit words.<br>0: fast flip<br>1: Slow flip |

## 7.4 AFIO registers

### 7.4.1 AFIO register overview

AFIO base address: 0x40010000

Table 7-53 AFIO register overview

| Offset | Register       | 31            | 30 | 29       | 28 | 27               | 26 | 25             | 24 | 23             | 22 | 21                | 20 | 19                | 18 | 17                | 16 | 15                | 14              | 13                 | 12 | 11                 | 10 | 9                  | 8               | 7                  | 6 | 5                    | 4 | 3                    | 2 | 1                    | 0 |                      |   |                |   |                 |   |                |   |                |   |                 |   |                 |   |                 |   |                 |   |                   |   |                   |   |                   |  |                   |  |
|--------|----------------|---------------|----|----------|----|------------------|----|----------------|----|----------------|----|-------------------|----|-------------------|----|-------------------|----|-------------------|-----------------|--------------------|----|--------------------|----|--------------------|-----------------|--------------------|---|----------------------|---|----------------------|---|----------------------|---|----------------------|---|----------------|---|-----------------|---|----------------|---|----------------|---|-----------------|---|-----------------|---|-----------------|---|-----------------|---|-------------------|---|-------------------|---|-------------------|--|-------------------|--|
| 000h   | AFIO_ECTRL     | Reserved      |    |          |    |                  |    |                |    |                |    |                   |    |                   |    |                   |    |                   |                 |                    |    |                    |    |                    |                 | EOE                |   | PORT_SEL[2:0]        |   | PIN_SEL[3:0]         |   |                      |   |                      |   |                |   |                 |   |                |   |                |   |                 |   |                 |   |                 |   |                 |   |                   |   |                   |   |                   |  |                   |  |
|        | Reset Value    | 0             |    |          |    |                  |    |                |    |                |    |                   |    |                   |    |                   |    |                   |                 |                    |    |                    |    |                    |                 | 0                  | 0 | 0                    | 0 | 0                    | 0 | 0                    | 0 | 0                    | 0 | 0              | 0 | 0               | 0 | 0              | 0 | 0              | 0 | 0               | 0 | 0               | 0 | 0               | 0 | 0               | 0 | 0                 | 0 | 0                 | 0 |                   |  |                   |  |
| 004h   | AFIO_RMP_CFG   | Reserved      |    |          |    | SW_JTAG_CFG[2:0] |    |                |    | MIL_RMIL_SEL   |    | Reserved          |    |                   |    | ADC2_ETRR         |    | ADC2_ETRI         |                 | ADC1_ETRR          |    | ADC1_ETRI          |    | TIM5CH4_RMP        |                 | PD01_RMP           |   | CAN1_RMP[1:0]        |   | TIM4_RMP             |   | TIM3_RMP[1:0]        |   | TIM2_RMP[1:0]        |   | TIM1_RMP[1:0]  |   | USART3_RMP[1:0] |   | USART2_RMP_0   |   | USART1_RMP     |   | I2C1_RMP        |   | SPI1_RMP_0      |   |                 |   |                 |   |                   |   |                   |   |                   |  |                   |  |
|        | Reset Value    | 0             |    |          |    | 0                |    |                |    | 0              |    | 0                 |    |                   |    | 0                 |    | 0                 |                 | 0                  |    | 0                  |    | 0                  |                 | 0                  |   | 0                    |   | 0                    |   | 0                    |   | 0                    |   | 0              |   | 0               |   | 0              |   | 0              |   |                 |   |                 |   |                 |   |                 |   |                   |   |                   |   |                   |  |                   |  |
| 008h   | AFIO_EXTI_CFG1 | Reserved      |    |          |    |                  |    |                |    |                |    |                   |    |                   |    | EXTI3_CFG[3:0]    |    |                   | EXTI2_CFG[3:0]  |                    |    | EXTI1_CFG[3:0]     |    |                    | EXTI0_CFG[3:0]  |                    |   |                      |   |                      |   |                      |   |                      |   |                |   |                 |   |                |   |                |   |                 |   |                 |   |                 |   |                 |   |                   |   |                   |   |                   |  |                   |  |
|        | Reset Value    | 0             |    |          |    |                  |    |                |    |                |    |                   |    |                   |    | 0                 |    |                   | 0               |                    |    | 0                  |    |                    | 0               |                    |   |                      |   |                      |   |                      |   |                      |   |                |   |                 |   |                |   |                |   |                 |   |                 |   |                 |   |                 |   |                   |   |                   |   |                   |  |                   |  |
| 00Ch   | AFIO_EXTI_CFG2 | Reserved      |    |          |    |                  |    |                |    |                |    |                   |    |                   |    | EXTI7_CFG[3:0]    |    |                   | EXTI6_CFG[3:0]  |                    |    | EXTI5_CFG[3:0]     |    |                    | EXTI4_CFG[3:0]  |                    |   |                      |   |                      |   |                      |   |                      |   |                |   |                 |   |                |   |                |   |                 |   |                 |   |                 |   |                 |   |                   |   |                   |   |                   |  |                   |  |
|        | Reset Value    | 0             |    |          |    |                  |    |                |    |                |    |                   |    |                   |    | 0                 |    |                   | 0               |                    |    | 0                  |    |                    | 0               |                    |   |                      |   |                      |   |                      |   |                      |   |                |   |                 |   |                |   |                |   |                 |   |                 |   |                 |   |                 |   |                   |   |                   |   |                   |  |                   |  |
| 010h   | AFIO_EXTI_CFG3 | Reserved      |    |          |    |                  |    |                |    |                |    |                   |    |                   |    | EXTI11_CFG[3:0]   |    |                   | EXTI10_CFG[3:0] |                    |    | EXTI9_CFG[3:0]     |    |                    | EXTI8_CFG[3:0]  |                    |   |                      |   |                      |   |                      |   |                      |   |                |   |                 |   |                |   |                |   |                 |   |                 |   |                 |   |                 |   |                   |   |                   |   |                   |  |                   |  |
|        | Reset Value    | 0             |    |          |    |                  |    |                |    |                |    |                   |    |                   |    | 0                 |    |                   | 0               |                    |    | 0                  |    |                    | 0               |                    |   |                      |   |                      |   |                      |   |                      |   |                |   |                 |   |                |   |                |   |                 |   |                 |   |                 |   |                 |   |                   |   |                   |   |                   |  |                   |  |
| 014h   | AFIO_EXTI_CFG4 | Reserved      |    |          |    |                  |    |                |    |                |    |                   |    |                   |    | EXTI15_CFG[3:0]   |    |                   | EXTI14_CFG[3:0] |                    |    | EXTI13_CFG[3:0]    |    |                    | EXTI12_CFG[3:0] |                    |   |                      |   |                      |   |                      |   |                      |   |                |   |                 |   |                |   |                |   |                 |   |                 |   |                 |   |                 |   |                   |   |                   |   |                   |  |                   |  |
|        | Reset Value    | 0             |    |          |    |                  |    |                |    |                |    |                   |    |                   |    | 0                 |    |                   | 0               |                    |    | 0                  |    |                    | 0               |                    |   |                      |   |                      |   |                      |   |                      |   |                |   |                 |   |                |   |                |   |                 |   |                 |   |                 |   |                 |   |                   |   |                   |   |                   |  |                   |  |
| 01Ch   | Reserved       |               |    |          |    |                  |    |                |    |                |    |                   |    |                   |    |                   |    |                   |                 |                    |    |                    |    |                    |                 |                    |   |                      |   |                      |   |                      |   |                      |   |                |   |                 |   |                |   |                |   |                 |   |                 |   |                 |   |                 |   |                   |   |                   |   |                   |  |                   |  |
| 020h   | AFIO_RMP_CFG3  | TIM8_RMP[1:0] |    | Reserved |    |                  |    | UART7_RMP[1:0] |    | UART6_RMP[1:0] |    | UART5_RMP[1:0]    |    | UART4_RMP[1:0]    |    | USART2_RMP_1      |    | SPI1_RMP_1        |                 | ETH_RMP[1:0]       |    | SPI3_RMP[1:0]      |    | SPI2_RMP[1:0]      |                 | I2C4_RMP[1:0]      |   | I2C3_RMP[1:0]        |   | I2C2_RMP[1:0]        |   | QSPI_RMP[1:0]        |   | Reserved             |   | CAN2_RMP[1:0]  |   | SDIO_RMP        |   |                |   |                |   |                 |   |                 |   |                 |   |                 |   |                   |   |                   |   |                   |  |                   |  |
|        | Reset Value    | 0             |    | 0        |    |                  |    | 0              |    | 0              |    | 0                 |    | 0                 |    | 0                 |    | 0                 |                 | 0                  |    | 0                  |    | 0                  |                 | 0                  |   | 0                    |   | 0                    |   | 0                    |   | 0                    |   | 0              |   | 0               |   |                |   |                |   |                 |   |                 |   |                 |   |                 |   |                   |   |                   |   |                   |  |                   |  |
| 024h   | AFIO_RMP_CFG4  | Reserved      |    |          |    | QSPI_MISO        |    | SPI3_NSS       |    | SPI2_NSS       |    | SPI1_NSS          |    | DVP_RMP[1:0]      |    | QSPI_XIP_EN       |    | Reserved          |                 | ADC4_ETRR          |    | ADC4_ETRI          |    | ADC3_ETRR          |                 | ADC3_ETRI          |   | Reserved             |   | COMP7_RMP            |   | COMP6_RMP[1:0]       |   | COMP5_RMP[1:0]       |   | COMP4_RMP[1:0] |   | COMP3_RMP[1:0]  |   | COMP2_RMP[1:0] |   | COMP1_RMP[1:0] |   |                 |   |                 |   |                 |   |                 |   |                   |   |                   |   |                   |  |                   |  |
|        | Reset Value    | 0             |    |          |    | 0                |    | 0              |    | 0              |    | 0                 |    | 0                 |    | 0                 |    | 0                 |                 | 0                  |    | 0                  |    | 0                  |                 | 0                  |   | 0                    |   | 0                    |   | 0                    |   | 0                    |   | 0              |   | 0               |   | 0              |   |                |   |                 |   |                 |   |                 |   |                 |   |                   |   |                   |   |                   |  |                   |  |
| 028h   | AFIO_RMP_CFG5  | Reserved      |    |          |    |                  |    |                |    |                |    | EMC_GB4_DETECT_EN |    | EMC_GB3_DETECT_EN |    | EMC_GB2_DETECT_EN |    | EMC_GB1_DETECT_EN |                 | EMC_GBN4_DETECT_EN |    | EMC_GBN3_DETECT_EN |    | EMC_GBN2_DETECT_EN |                 | EMC_GBN1_DETECT_EN |   | EMC_CLAMP4_DETECT_EN |   | EMC_CLAMP3_DETECT_EN |   | EMC_CLAMP2_DETECT_EN |   | EMC_CLAMP1_DETECT_EN |   | EMC_GB4_RST_EN |   | EMC_GB3_RST_EN  |   | EMC_GB2_RST_EN |   | EMC_GB1_RST_EN |   | EMC_GBN4_RST_EN |   | EMC_GBN3_RST_EN |   | EMC_GBN2_RST_EN |   | EMC_GBN1_RST_EN |   | EMC_CLAMP4_RST_EN |   | EMC_CLAMP3_RST_EN |   | EMC_CLAMP2_RST_EN |  | EMC_CLAMP1_RST_EN |  |
|        | Reset Value    | 0             |    |          |    |                  |    |                |    |                |    | 0                 |    | 0                 |    | 0                 |    | 0                 |                 | 0                  |    | 0                  |    | 0                  |                 | 0                  |   | 0                    |   | 0                    |   | 0                    |   | 0                    |   | 0              |   | 0               |   | 0              |   | 0              |   | 0               |   | 0               |   | 0               |   | 0               |   | 0                 |   |                   |   |                   |  |                   |  |

### 7.4.2 AFIO event control register (AFIO\_ECTRL)

Address offset: 0x00

Reset value: 0x0000 0000

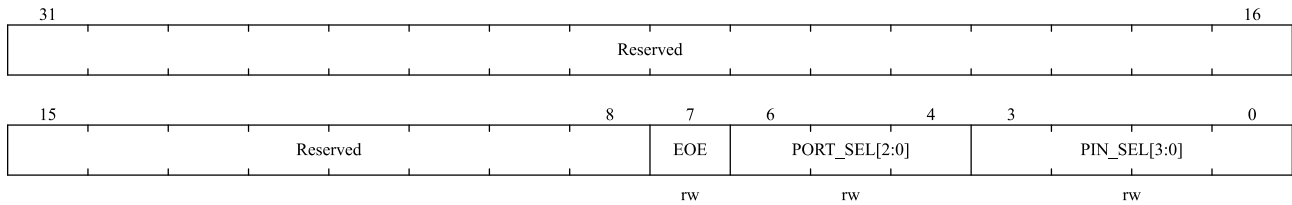

| Bit field | Name          | Description   |
|-----------|---------------|---|
| 31:8      | Reserved      | Reserved, the reset value must be maintained.   |
| 7         | EOE           | Event output enable bit.<br>When this bit is set, the Cortex event output signal will be connected to the I/O port selected by PORT_SEL[2:0] and PIN_SEL[3:0].<br>0: Output disable<br>1: Output enable   |
| 6:4       | PORT_SEL[2:0] | Port selection bit<br>Select the port used to output the event output signal of cortex:<br>000: select port A<br>001: select port B<br>010: select port C<br>011: select port D<br>100: select port E   |
| 3:0       | PIN_SEL[3:0]  | Pin select bit<br>Select the pin used to output the Cortex event output signal, (x=A...E) corresponding to the I/O selected by PORT_SEL[2:0].<br>0000: select Px0 0001: select Px1 0010: select Px2 0011: select Px3<br>0100: select Px4 0101: select Px5 0110: select Px6 0111: select Px7<br>1000: select Px8 1001: select Px9 1010: select Px10 1011: select Px11<br>1100: select Px12 1101: select Px13 1110: select Px14 1111: select Px15 |

### 7.4.3 AFIO alternate remap configuration register (AFIO\_RMP\_CFG)

Address offset: 0x04

Reset value: 0x0000 0000

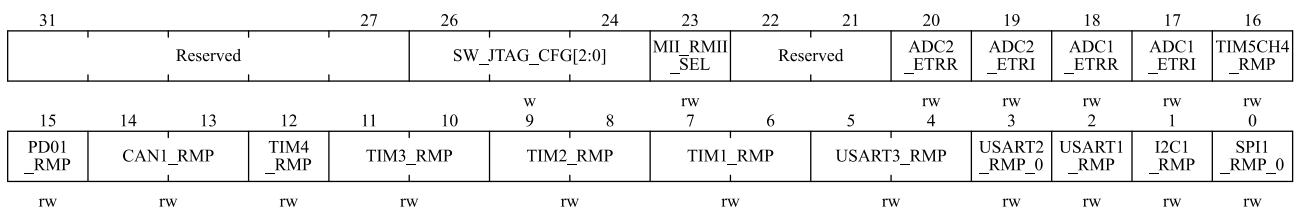

| Bit field | Name             | Description  |
|-----------|------------------|--|
| 31:27     | Reserved         | Reserved, the reset value must be maintained.  |
| 26:24     | SW_JTAG_CFG[2:0] | <p>Serial wire JTAG configuration</p> <p>These bits can only be written by software (reading these bits will return an undefined value) and are used to configure the I/O ports of the SWD-JTAG alternate function. SWD-JTAG (Serial Wire JTAG) supports JTAG or SWD to access Cortex's debug port. The default state after system reset is to enable SWD-JTAG. In this state, JTAG or SW (serial wire) mode can be selected through a specific signal on the JTMS/JTCK pin.</p> <p>000: Full SWJ (JTAG-DP + SW-DP): reset state;<br/>           001: Full SWJ (JTAG-DP + SW-DP) but no NJTRST;<br/>           010: Turn off JTAG-DP and enable SW-DP;<br/>           100: Turn off JTAG-DP, turn off SW-DP;<br/>           Other values: no effect.</p> |
| 23        | MII_RMII_SEL     | <p>Ethernet MAC connection mode selection bit.</p> <p>This bit can be set to '1' or set to '0' by software. It configures the internal Ethernet MAC to use the external MII interface or the transceiver PHY of the RMII interface.</p> <p>0: Configure the Ethernet MAC to use the transceiver of the external MII interface;<br/>           1: Configure the Ethernet MAC to use the transceiver of the external RMII interface.</p>   |
| 22:21     | Reserved         | Reserved, the reset value must be maintained.  |
| 20        | ADC2_ETRR        | <p>ADC2 regular conversion external trigger remapping</p> <p>This bit can be set to '1' or set to '0' by software. It controls the trigger input connected to the external trigger of ADC2 regular conversion.</p> <p>0: ADC2 regular conversion external trigger is connected to EXTI11<br/>           1: ADC2 regular conversion external trigger is connected to TIM8_TRGO</p>  |
| 19        | ADC2_ETRI        | <p>ADC2 injection conversion external trigger remapping</p> <p>This bit can be set to '1' or set to '0' by software. It controls the trigger input connected to the ADC2 injection conversion external trigger.</p> <p>0: ADC2 injection conversion external trigger is connected to EXTI15<br/>           1: ADC2 injection conversion external trigger is connected to TIM8_CH4.</p>   |
| 18        | ADC1_ETRR        | <p>ADC1 regular conversion external trigger remapping</p> <p>This bit can be set to '1' or set to '0' by software. It controls the trigger input connected to the external trigger of ADC1 regular conversion.</p> <p>0: ADC1 regular conversion external trigger is connected to EXTI11<br/>           1: ADC1 regular conversion external trigger is connected to TIM8_TRGO</p>  |
| 17        | ADC1_ETRI        | <p>ADC1 injection conversion external trigger remapping</p> <p>This bit can be set to '1' or set to '0' by software. It controls the trigger input connected to the ADC1 injection conversion external trigger.</p> <p>0: ADC1 injection conversion external trigger is connected to EXTI15<br/>           1: ADC1 injection conversion external trigger is connected to TIM8_CH4</p>  |
| 16        | TIM5CH4_RMP      | TIM5_CH4 internal remapping  |

| Bit field | Name          | Description  |
|-----------|---------------|--|
|           |               | <p>This bit can be set to '1' or set to '0' by software. It controls the internal image of TIM5_CH4.</p> <p>0: TIM5_CH4 is connected to PA3</p> <p>1: LSI internal oscillator is connected to TIM5_CH4, the purpose is to calibrate the LSI</p>  |
| 15        | PD01_RMP      | <p>PD0/PD1 mapping on OSC_IN/OSC_OUT (PD0/PD1 mapping on OSC_IN/OSC_OUT)</p> <p>This bit can be set to '1' or set to '0' by software. It controls the GPIO function image of PD0 and PD1. When the main oscillator HSE is not used (the system runs on the internal 8MHz RC oscillator), PD0 and PD1 can be mapped to the OSC_IN and OSC_OUT pins. This function can only be applied to packages with pins below 80 (PD0 and PD1 appear on packages with pins 80 and above and do not need to be remapped).</p> <p>0: Do not remap PD0 and PD1;</p> <p>1: PD0 is mapped to OSC_IN, PD1 is mapped to OSC_OUT.</p> |
| 14:13     | CAN1_RMP[1:0] | <p>CAN1 alternate function remapping</p> <p>These bits can be set to '1' or set to '0' by software to control the re-mapping of the alternate functions CAN1_RX and CAN1_TX on products with only a single CAN1 interface.</p> <p>00: CAN1_RX is mapped to PA11, CAN1_TX is mapped to PA12;</p> <p>01: CAN1_RX is mapped to PD8, CAN1_TX is mapped to PD9;</p> <p>10: CAN1_RX is mapped to PB8, CAN1_TX is mapped to PB9 (cannot be used for 36-pin package);</p> <p>11: CAN1_RX is mapped to PD0, CAN1_TX is mapped to PD1.</p>   |
| 12        | TIM4_RMP      | <p>Remapping of Timer 4</p> <p>This bit can be set to '1' or set to '0' by software to control the mapping of channels 1-4 of TIM4 to the GPIO port.</p> <p>0: No remapping (TIM4_CH1/PB6, TIM4_CH2/PB7, TIM4_CH3/PB8, TIM4_CH4/PB9);</p> <p>1: Full image (TIM4_CH1/PD12, TIM4_CH2/PD13, TIM4_CH3/PD14, TIM4_CH4/PD15).</p> <p><i>Note: Remapping does not affect TIM4_ETR on PE0.</i></p>  |
| 11:10     | TIM3_RMP[1:0] | <p>Remapping of Timer 3</p> <p>These bits can be set to '1' or set to '0' by software to control the image of Timer 3 channels 1 to 4 on the GPIO port.</p> <p>00: no remapping (CH1/PA6, CH2/PA7, CH3/PB0, CH4/PB1);</p> <p>01: unused combination;</p> <p>10: Partial image (CH1/PB4, CH2/PB5, CH3/PB0, CH4/PB1);</p> <p>11: Full image (CH1/PC6, CH2/PC7, CH3/PC8, CH4/PC9).</p> <p><i>Note: Remapping does not affect TIM3_ETR on PD2.</i></p>   |
| 9:8       | TIM2_RMP[1:0] | <p>Remapping of Timer 2</p> <p>These bits can be set to '1' or set to '0' by software to control the image of Timer 2 channels 1 to 4 and external trigger (ETR) on the GPIO port.</p>   |

| Bit field | Name            | Description   |
|-----------|-----------------|---|
|           |                 | 00: no remapping (CH1/ETR/PA0, CH2/PA1, CH3/PA2, CH4/PA3);<br>01: Partial image (CH1/ETR/PA15, CH2/PB3, CH3/PA2, CH4/PA3);<br>10: Partial image (CH1/ETR/PA0, CH2/PA1, CH3/PB10, CH4/PB11);<br>11: Complete image (CH1/ETR/PA15, CH2/PB3, CH3/PB10, CH4/PB11).  |
| 7:6       | TIM1_RMP[1:0]   | Remapping of Timer 1<br>These bits can be set to '1' or set to '0' by software to control timer 1 channels 1 to 4, 1N to 3N, external trigger (ETR) and brake input (BKIN) The image on the GPIO port.<br>00: no remap (ETR/PA12, CH1/PA8, CH2/PA9, CH3/PA10, CH4/PA11, BKIN/PB12, CH1N/PB13, CH2N/PB14, CH3N/PB15);<br>01: partial image (ETR/ PA12, CH1/PA8, CH2/PA9, CH3/PA10, CH4/PA11, BKIN/PA6, CH1N/PA7, CH2N/PB0, CH3N/PB1);<br>10: Partial image (ETR/PA12, CH1/PA8, CH2/PA9, CH3/PA10, CH4/PA11, BKIN/PB5, CH1N/PB13, CH2N/PB14, CH3N/PB15);<br>11: Full image (ETR/PE7, CH1/PE9, CH2/PE11, CH3/PE13, CH4/PE14, BKIN/PE15, CH1N/PE8, CH2N/PE10, CH3N/PE12). |
| 5:4       | USART3_RMP[1:0] | Remapping of USART3<br>These bits can be set to '1' or set to '0' by software to control the image of the CTS, RTS, CK, TX and RX alternate functions of USART3 on the GPIO port.<br>00: No remapping (TX/PB10, RX/PB11, CK/PB12, CTS/PB13, RTS/PB14);<br>01: Partial image (TX/PC10, RX/PC11, CK/PC12, CTS/PB13, RTS/PB14);<br>10: Unused combination;<br>11: Full image (TX/PD8, RX/PD9, CK/PD10, CTS/PD11, RTS/PD12)..   |
| 3         | USART2_RMP_0    | Remapping of USART2<br>These bits can be set to '1' or set to '0' by software and used in conjunction with USART2_RMP_1 to form USART2_RMP[1:0] to control the image of the CTS, RTS, CK, TX and RX alternate functions of USART2 on the GPIO port.<br>00: No remapping (CTS/PA0, RTS/PA1, TX/PA2, RX/PA3, CK/PA4);<br>01: Remapping (CTS/PD3, RTS/PD4, TX/PD5, RX/PD6, CK/PD7);<br>10: Remapping (CTS/PC6, RTS/PC7, TX/PC8, RX/PC9, CK/-);<br>11: Remapping (CTS/PA15, RTS/PB3, TX/PB4, RX/PB5, CK/PA4).<br><i>Note: Synchronous mode is not supported when the USART2_RMP[1:0] is 10 .</i>  |
| 2         | USART1_RMP[1:0] | Remapping of USART1<br>This bit can be set to '1' or set to '0' by software to control the image of the TX and RX alternate functions of USART1 on the GPIO port.<br>0: No remapping (TX/PA9, RX/PA10);<br>1: Remapping (TX/PB6, RX/PB7).   |
| 1         | I2C1_RMP        | Remapping of I2C1<br>This bit can be set to '1' or set to '0' by software to control the image of I2C1's SCL and SDA alternate functions on the GPIO port.<br>0: No remapping (SCL/PB6, SDA/PB7);<br>1: Remapping (SCL/PB8, SDA/PB9).   |
| 0         | SPI1_RMP_0      | Remapping of SPI1   |

| Bit field | Name | Description  |
|-----------|------|--|
|           |      | <p>This bit can be set to '1' or set to '0' by software and used in conjunction with SPI1_RMP_1 to form SPI1_RMP[1:0] to control the image of SPI1's NSS, SCK, MISO and MOSI alternate functions on the GPIO port.</p> <p>00: No remapping (NSS/PA4, SCK/PA5, MISO/PA6, MOSI/PA7);</p> <p>01: Remapping (NSS/PA15, SCK/PB3, MISO/PB4, MOSI/PB5);</p> <p>10: Remapping (NSS/PB2, SCK/PA5, MISO/PA6, MOSI/PA7);</p> <p>11: Remapping (NSS/PB2, SCK/PE7, MISO/PE8, MOSI/PE9);</p> |

#### 7.4.4 AFIO external interrupt configuration register 1(AFIO\_EXTI\_CFG1)

Address offset: 0x08

Reset value: 0x0000 0000

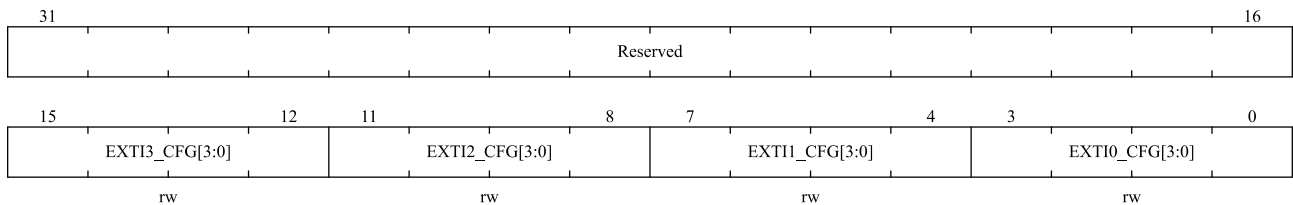

| Bit field | Name           | Description   |
|-----------|----------------|---|
| 31:16     | Reserved       | Reserved, the reset value must be maintained.   |
| 15:0      | EXT�x_CFG[3:0] | <p>EXT�x configuration (x = 0... 3)</p> <p>These bits can be read and written by software and used to select the input source of the EXT�x external interrupt.</p> <p>EXT�0 configuration:</p> <p>0000: PA0 pin    0001: PB0 pin    0010: PC0 pin<br/> 0011: PD0 pin    0100: PE0 pin    0101: Reserved<br/> 0110: PG0 pin</p> <p>EXT�1 configuration:</p> <p>0000: PA1 pin    0001: PB1 pin    0010: PC1 pin<br/> 0011: PD1 pin    0100: PE1 pin    0101: PF1 pin<br/> 0110: PG1 pin</p> <p>EXT�2 configuration:</p> <p>0000: PA2 pin    0001: PB2 pin    0010: PC2 pin<br/> 0011: PD2 pin    0100: PE2 pin    0101: PF2 pin<br/> 0110: PG2 pin</p> <p>EXT�3 configuration:</p> <p>0000: PA3 pin    0001: PB3 pin    0010: PC3 pin<br/> 0011: PD3 pin    0100: PE3 pin    0101: PF3 pin<br/> 0110: PG3 pin</p> |

### 7.4.5 AFIO external interrupt configuration register 2(AFIO\_EXTI\_CFG2)

Address offset: 0x0C

Reset value: 0x0000 0000

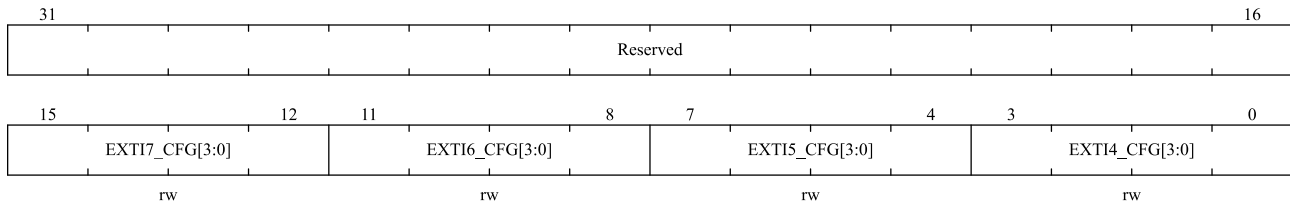

| Bit field | Name           | Description   |
|-----------|----------------|---|
| 31:16     | Reserved       | Reserved, the reset value must be maintained.   |
| 15:0      | EXTIx_CFG[3:0] | EXTIx configuration (x = 4... 7)<br>These bits can be read and written by software and used to select the input source of the EXTIx external interrupt.<br>EXTI4 configuration:<br>0000: PA4 pin    0001: PB4 pin    0010: PC4 pin<br>0011: PD4 pin    0100: PE4 pin    0101: PF4 pin<br>0110: PG4 pin<br>EXTI5 configuration:<br>0000: PA5 pin    0001: PB5 pin    0010: PC5 pin<br>0011: PD5 pin    0100: PE5 pin    0101: PF5 pin<br>0110: PG5 pin<br>EXTI6 configuration:<br>0000: PA6 pin    0001: PB6 pin    0010: PC6 pin<br>0011: PD6 pin    0100: PE6 pin    0101: Reserved<br>0110: Reserved<br>EXTI7 configuration:<br>0000: PA7 pin    0001: PB7 pin    0010: PC7 pin<br>0011: PD7 pin    0100: PE7 pin    0101: Reserved<br>0110: Reserved |

### 7.4.6 AFIO external interrupt configuration register 3(AFIO\_EXTI\_CFG3)

Address offset: 0x10

Reset value: 0x0000 0000

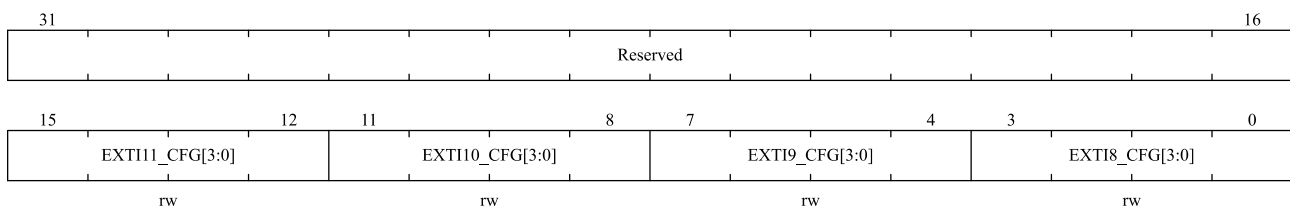

| Bit field | Name           | Description   |
|-----------|----------------|---|
| 31:16     | Reserved       | Reserved, the reset value must be maintained.   |
| 15:0      | EXTIx_CFG[3:0] | EXTIx configuration (x = 8... 11)<br>These bits can be read and written by software and used to select the input source of the EXTIx external interrupt.<br>EXTI8 configuration:<br>0000: PA8 pin    0001: PB8 pin    0010: PC8 pin<br>0011: PD8 pin    0100: PE8 pin    0101: Reserved<br>0110: Reserved<br>EXTI9 configuration:<br>0000: PA9 pin    0001: PB9 pin    0010: PC9 pin<br>0011: PD9 pin    0100: PE9 pin    0101: Reserved<br>0110: PG9 pin<br>EXTI10 configuration:<br>0000: PA10 pin    0001: PB10 pin    0010: PC10 pin<br>0011: PD10 pin    0100: PE10 pin    0101: Reserved<br>0110: Reserved<br>EXTI11 configuration:<br>0000: PA11 pin    0001: PB11 pin    0011: PC10 pin<br>0011: PD11 pin    0100: PE11 pin    0101: Reserved<br>0110: Reserved |

### 7.4.7 AFIO external interrupt configuration register 4(AFIO\_EXTI\_CFG4)

Address offset: 0x14

Reset value: 0x0000 0000

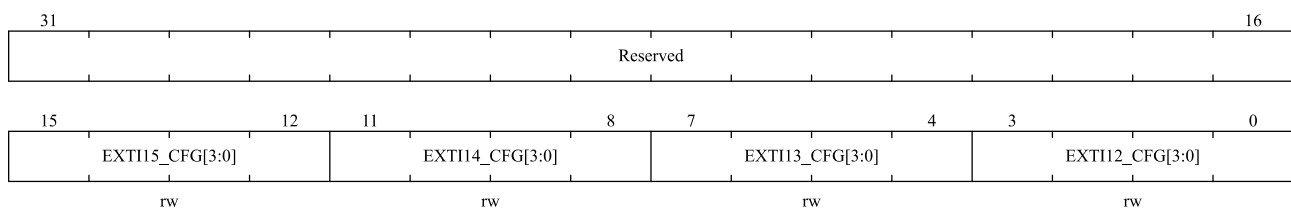

| Bit field | Name           | Description   |
|-----------|----------------|---|
| 31:16     | Reserved       | Reserved, the reset value must be maintained.   |
| 15:0      | EXTIx_CFG[3:0] | EXTIx configuration (x = 12... 15)<br>These bits can be read and written by software and used to select the input source of the EXTIx external interrupt.<br>EXTI12 configuration:<br>0000: PA12 pin    0001: PB12 pin    0011: PC12 pin<br>0011: PD12 pin    0100: PE12 pin    0101: PF12 pin<br>0110: Reserved<br>EXTI13 configuration:<br>0000: PA13 pin    0001: PB13 pin    0011: PC13 pin |

| Bit field | Name | Description  |
|-----------|------|--|
|           |      | 0011: PD13 pin 0100: PE13 pin 0101: PF13 pin<br>0110: Reserved<br>EXTI14 configuration:<br>0000: PA14 pin 0001: PB14 pin 0011: PC14 pin<br>0011: PD14 pin 0100: PE14 pin 0101: PF14 pin<br>0110: Reserved<br>EXTI15 configuration:<br>0000: PA15 pin 0001: PB15 pin 0011: PC15 pin<br>0011: PD15 pin 0100: PE15 pin 0101: PF15 pin<br>0110: Reserved |

### 7.4.8 AFIO alternate remapping configuration register 3(AFIO\_RMP\_CFG3)

Address offset: 0x20

Reset value: 0x0000 0000

|               |    |               |    |                |    |                |    |                |    |                |    |              |               |              |          |
|---------------|----|---------------|----|----------------|----|----------------|----|----------------|----|----------------|----|--------------|---------------|--------------|----------|
| 31            | 30 | 29            | 28 | 27             | 26 | 25             | 24 | 23             | 22 | 21             | 20 | 19           | 18            | 17           | 16       |
| TIM8_RMP[1:0] |    | Reserved      |    | UART7_RMP[1:0] |    | UART6_RMP[1:0] |    | UART5_RMP[1:0] |    | UART4_RMP[1:0] |    | USART2_RMP_1 | SPI1_RMP_1    | ETH_RMP[1:0] |          |
| rw            |    |               |    | rw             |    | rw             |    | rw             |    | rw             |    | rw           | rw            | rw           |          |
| 15            | 14 | 13            | 12 | 11             | 10 | 9              | 8  | 7              | 6  | 5              | 4  | 3            | 2             | 1            | 0        |
| SPI3_RMP[1:0] |    | SPI2_RMP[1:0] |    | I2C4_RMP[1:0]  |    | I2C3_RMP[1:0]  |    | I2C2_RMP[1:0]  |    | QSPI_RMP[1:0]  |    | Reserved     | CAN2_RMP[1:0] |              | SDIO_RMP |
| rw            |    | rw            |    | rw             |    | rw             |    | rw             |    | rw             |    |              | rw            |              | rw       |

| Bit field | Name           | Description  |
|-----------|----------------|--|
| 31:30     | TIM8_RMP[1:0]  | Remapping of Timer 8<br>These bits can be set to '1' or set to '0' by software to control the image of Timer 8 channels 1 to 2 on the GPIO port.<br>00: No remapping (ETR/PA0, CH1/PC6, CH2/PC7, CH3/PC8, CH4/PC9, BKIN/PA6, CH1N/PA7, CH2N/PB0, CH3N/PB1);<br>01: Partial image (ETR/PB4, CH1/PC6, CH2/PC7, CH3/PC8, CH4/PC9, BKIN/PB3, CH1N/PA15, CH2N/PC12, CH3N/PD2);<br>10: Unused combination;<br>11: Partial image (ETR/PB4, CH1/PD14, CH2/PD15, CH3/PC8, CH4/PC9, BKIN/PB3, CH1N/PA15, CH2N/PC12, CH3N/PD2). |
| 29:28     | Reserved       | Reserved, the reset value must be maintained.  |
| 27:26     | UART7_RMP[1:0] | Remapping of UART7<br>These bits can be set to '1' or set to '0' by software to control the image of the TX and RX alternate functions of UART7 on the GPIO port.<br>00: No remapping (TX/PC4, RX/PC5);<br>01: Remapping (TX/PC2, RX/PC3);<br>10: Unused combination;<br>11: Remapping (TX/PG0, RX/PG1).   |
| 25:24     | UART6_RMP[1:0] | Remapping of UART6   |

| Bit field | Name           | Description   |
|-----------|----------------|---|
|           |                | <p>These bits can be set to '1' or set to '0' by software to control the image of the TX and RX alternate functions of UART6 on the GPIO port.</p> <p>00: No remapping (TX/PE2, RX/PE3);</p> <p>01: Unused combination;</p> <p>10: Remapping (TX/PC0, RX/PC1);</p> <p>11: Remapping (TX/PB0, RX/PB1).</p>   |
| 23:22     | UART5_RMP[1:0] | <p>Remapping of UART5</p> <p>These bits can be set to '1' or set to '0' by software to control the image of the TX and RX alternate functions of UART5 on the GPIO port.</p> <p>00: No remapping (TX/PC12, RX/PD2);</p> <p>01: Remapping (TX/PB13, RX/PB14);</p> <p>10: Remapping (TX/PE8, RX/PE9);</p> <p>11: Remapping (TX/PB8, RX/PB9).</p>  |
| 21:20     | UART4_RMP[1:0] | <p>Remapping of UART4</p> <p>These bits can be set to '1' or set to '0' by software to control the image of the TX and RX alternate functions of UART4 on the GPIO port.</p> <p>00: No remapping (TX/PC10, RX/PC11);</p> <p>01: Remapping (TX/PB2, RX/PE7);</p> <p>10: Remapping (TX/PA13, RX/PA14);</p> <p>11: Remapping (TX/PD0, RX/PD1).</p>   |
| 19        | USART2_RMP_1   | <p>Remapping of USART2</p> <p>These bits can be set to '1' or set to '0' by software and used in conjunction with USART2_RMP_0 to form USART2_RMP[1:0] to control the image of the CTS, RTS, CK, TX and RX alternate functions of USART2 on the GPIO port.</p> <p>00: No remapping (CTS/PA0, RTS/PA1, TX/PA2, RX/PA3, CK/PA4);</p> <p>01: Remapping (CTS/PD3, RTS/PD4, TX/PD5, RX/PD6, CK/PD7);</p> <p>10: Remapping (CTS/PC6, RTS/PC7, TX/PC8, RX/PC9, CK/-);</p> <p>11: Remapping (CTS/PA15, RTS/PB3, TX/PB4, RX/PB5, CK/PA4).</p> <p><i>Note: Synchronous mode is not supported when the USART2_RMP[1:0] is 10 .</i></p> |
| 18        | SPI1_RMP_1     | <p>Remapping of SPI1</p> <p>This bit can be set to '1' or set to '0' by software and used in conjunction with SPI1_RMP_0 to form SPI1_RMP[1:0] to control the image of NSS, SCK, MISO and MOSI alternate functions of SPI1 on the GPIO port.</p> <p>00: No remapping (NSS/PA4, SCK/PA5, MISO/PA6, MOSI/PA7);</p> <p>01: Remapping (NSS/PA15, SCK/PB3, MISO/PB4, MOSI/PB5);</p> <p>10: Remapping (NSS/PB2, SCK/PA5, MISO/PA6, MOSI/PA7);</p> <p>11: Remapping (NSS/PB2, SCK/PE7, MISO/PE8, MOSI/PE9);</p>  |
| 17:16     | ETH_RMP[1:0]   | <p>Pin configuration of Ethernet MAC</p> <p>This bit can be set to '1' or '0' by software. It controls the connection of the Ethernet MAC to the external transceiver PHY.</p> <p>00: No remapping (RX_DV/CRS_DV/PA7, RXD0/PC4, RXD1/PC5, RXD2/PB0, RXD3/PB1, PPS_OUT/PB5, TXD3/PB8);</p> <p>01: Remapping (RX_DV/CRS_DV/PD8, RXD0/PD9, RXD1/PD10, RXD2/PD11,</p>   |

| Bit field | Name          | Description  |
|-----------|---------------|--|
|           |               | RXD3/PD12, PPS_OUT/PB5, TXD3/PB8);<br>10: Remapping (RX_DV/CRS_DV/PA7, RXD0/PC4, RXD1/PC5, RXD2/PB0, RXD3/PB1, PPS_OUT/PB6, TXD3/PB7);<br>11: Remapping (RX_DV/CRS_DV/PD8, RXD0/PD9, RXD1/PD10, RXD2/PB0, RXD3/PB1, PPS_OUT/PB6, TXD3/PB7).  |
| 15:14     | SPI3_RMP[1:0] | Remapping of SPI3<br>This bit can be set to '1' or set to '0' by software to control the image of the NSS, SCK, MISO and MOSI alternate functions of SPI3 on the GPIO port.<br>00: No remapping (NSS/WS/PA15, SCK/CK/PB3, MISO/PB4, MOSI/PB5);<br>01: Remapping (NSS/WS/PD2, SCK/CK/PC10, MISO/PC11, MOSI/PC12);<br>10: Remapping (NSS/WS/PD8, SCK/CK/PD9, MISO/PD11, MOSI/PD12);<br>11: Remapping (NSS/WS/PC2, SCK/CK/PC3, MISO/PA0, MOSI/PA1). |
| 13:12     | SPI2_RMP[1:0] | Remapping of SPI2<br>This bit can be set to '1' or set to '0' by software to control the image of the NSS, SCK, MISO and MOSI alternate functions of SPI2 on the GPIO port.<br>00: No remapping (NSS/WS/PB12, SCK/CK/PB13, MISO/PB14, MOSI/PB15);<br>01: Remapping (NSS/WS/PC6, SCK/CK/PC7, MISO/PC8, MOSI/PC9);<br>10: Unused combination;<br>11: Remapping (NSS/WS/PE10, SCK/CK/PE11, MISO/PE12, MOSI/PE13).                                   |
| 11:10     | I2C4_RMP[1:0] | I2C4 remapping<br>This bit can be set to '1' or set to '0' by software to control the image of I2C4's SDA and SCL alternate functions on the GPIO port.<br>00: No remapping (SCL/PC6, SDA/PC7);<br>01: Remapping (SCL/PD14, SDA/PD15);<br>10: Unused combination;<br>11: Remapping (SCL/PA9, SDA/PA10).  |
| 9:8       | I2C3_RMP[1:0] | I2C3 remapping<br>This bit can be set to '1' or set to '0' by software to control the image of I2C3's SDA and SCL alternate functions on the GPIO port.<br>00: No remapping (SCL/PC0, SDA/PC1);<br>01: Unused combination;<br>10: Remapping (SCL/PF4, SDA/PF5);<br>11: Remapping (SCL/PA4, SDA/PC5).   |
| 7:6       | I2C2_RMP[1:0] | I2C2 remapping<br>This bit can be set to '1' or set to '0' by software to control the image of I2C2's SDA and SCL alternate functions on the GPIO port.<br>00: No remapping (SCL/PB10, SDA/PB11);<br>01: Remapping (SCL/PG2, SDA/PG3);<br>10: Unused combination;<br>11: Remapping (SCL/PC4, SDA/PA5).   |
| 5:4       | QSPI_RMP[1:0] | Remapping of QSPI<br>This bit can be set to '1' or set to '0' by software to control the image of QSPI's IO0, IO1, IO2, IO3, CLK, and NSS alternate functions on the GPIO port.  |

| Bit field | Name          | Description   |
|-----------|---------------|---|
|           |               | 00: No remapping (NSS/PA4, SCK/PA5, IO0/PA6, IO1/PA7, IO2/PC4, IO3/PC5);<br>01: Unused combination;<br>10: Remapping (NSS/PF0, SCK/PF1, IO0/PF2, IO1/PF3, IO2/PF4, IO3/PF5);<br>11: Remapping (NSS/PC10, SCK/PC11, IO0/PC12, IO1/PD0, IO2/PD1, IO3/PD2).  |
| 3         | Reserved      | Reserved, the reset value must be maintained.   |
| 2:1       | CAN2_RMP[1:0] | CAN2 remapping<br>This bit can be set to '1' or set to '0' by software to control the image of the CAN2_RX and CAN2_TX alternate functions of CAN2 on the GPIO port.<br>00: No remapping (RX/PB12, TX/PB13);<br>01: Remapping (RX/PB5, TX/PB6);<br>10: Unused combination;<br>11: Remapping (RX/PD10, TX/PD11).               |
| 0         | SDIO_RMP      | SDIO remapping<br>This bit can be set to '1' or set to '0' by software to control the image of the alternate function port. D4/PB8, D5/PB9, D6/PC6, D7/PC7 are not re-imaged.<br>0: No remapping (DO/PC8, D1/PC9, D2/PC10, D3/PC11, CK/PC12, CMD/PD2);<br>1: Remapping (DO/PE8, D1/PE9, D2/PE10, D3/PE11, CK/PE12, CMD/PE13); |

### 7.4.9 AFIO alternate remap configuration register 4 (AFIO\_RMP\_CFG4)

Address offset: 0x24

Reset value: 0x0000 0000

|           |           |          |  |           |                |    |                |    |                |           |                |          |                |              |                |             |              |           |           |    |  |    |  |    |  |    |  |   |  |   |  |
|-----------|-----------|----------|--|-----------|----------------|----|----------------|----|----------------|-----------|----------------|----------|----------------|--------------|----------------|-------------|--------------|-----------|-----------|----|--|----|--|----|--|----|--|---|--|---|--|
| 31        |           |          |  | 26        |                |    |                | 25 |                | 24        |                | 23       |                | 22           |                | 21          |              | 20        |           | 19 |  | 18 |  | 17 |  | 16 |  |   |  |   |  |
| Reserved  |           |          |  |           |                |    |                |    |                | QSPI_MISO | SPI3_NSS       | SPI2_NSS | SPI1_NSS       | DVP_RMP[1:0] |                | QSPI_XIP_EN | TSC_OUT_CTRL | ADC4_ETRR | ADC4_ETRI |    |  |    |  |    |  |    |  |   |  |   |  |
| 15        |           | 14       |  | 13        |                | 12 |                | 11 |                | 10        |                | 9        |                | 8            |                | 7           |              | 6         |           | 5  |  | 4  |  | 3  |  | 2  |  | 1 |  | 0 |  |
| ADC3_ETRR | ADC3_ETRI | Reserved |  | COMP7_RMP | COMP6_RMP[1:0] |    | COMP5_RMP[1:0] |    | COMP4_RMP[1:0] |           | COMP3_RMP[1:0] |          | COMP2_RMP[1:0] |              | COMP1_RMP[1:0] |             |              |           |           |    |  |    |  |    |  |    |  |   |  |   |  |
| rw        | rw        |          |  | rw        | rw             |    | rw             |    | rw             |           | rw             |          | rw             |              | rw             |             |              |           |           |    |  |    |  |    |  |    |  |   |  |   |  |

| Bit field | Name      | Description   |
|-----------|-----------|---|
| 31:26     | Reserved  | Reserved, the reset value must be maintained.   |
| 25        | QSPI_MISO | The IO1 pin of QSPI is equivalent to MISO in standard single-wire mode, and the pin attributes can be configured as:<br>0: The QSPI module automatically controls whether it is input or output<br>1: Fixed as input floating |
| 24        | SPI3_NSS  | NSS mode bit of SPI3 (when NSS is configured as AFIO push-pull).<br>0: NSS is high impedance when idle<br>1: NSS is 1 when idle   |
| 23        | SPI2_NSS  | NSS mode bit of SPI2 (when NSS is configured as AFIO push-pull).<br>0: NSS is high impedance when idle<br>1: NSS is 1 when idle   |
| 22        | SPI1_NSS  | NSS mode bit of SPI1 (when NSS is configured as AFIO push-pull).<br>0: NSS is high impedance when idle  |

| Bit field | Name           | Description   |
|-----------|----------------|---|
|           |                | 1: NSS is 1 when idle   |
| 21:20     | DVP_RMP[1:0]   | Remapping of DVP<br>This bit can be set to '1' or '0' by software.<br>00: No remapping (HSYNC/PA1, VSYNC/PA2, CLK/PA3, D0/PA4, D1/PA5, D2/PA6, D3/PA7, D4/PC4, D5/PC5, D6/PB0, D7/PB1) ;<br>01: Remapping (HSYNC/PE2, VSYNC/PE3, CLK/PE4, D0/PE5, D1/PE6, D2/PC0, D3/PB2, D4/PF12, D5/PF13, D6/PF14, D7/PF15);<br>10: Unused combination;<br>11: Remapping (HSYNC/PE2, VSYNC/PE3, CLK/PE4, D0/PE5, D1/PE6, D2/PC0, D3/PB2, D4/PB10, D5/PB11, D6/PF14, D7/PF15). |
| 19        | QSPI_XIP_EN    | QSPI XIP memory mapping mode enable control<br>0: Disable<br>1: Enable  |
| 18        | Reserved       | Reserved, the reset value must be maintained.   |
| 17        | ADC4_ETRR      | ADC4 regular conversion external trigger remapping<br>This bit can be set to '1' or '0' by software. It controls the trigger input connected to the external trigger of ADC4 regular conversion.<br>0: ADC4 regular conversion external trigger is connected to EXTI10<br>1: ADC4 regular conversion external trigger is connected to TIM5_CH3  |
| 16        | ADC4_ETRI      | ADC4 injection conversion external trigger remapping<br>This bit can be set to '1' or '0' by software. It controls the trigger input connected to the ADC4 injection conversion external trigger.<br>0: ADC4 injection conversion external trigger is connected to EXTI14<br>1: ADC4 injection conversion external trigger is connected to TIM5_CH4.  |
| 15        | ADC3_ETRR      | ADC3 regular conversion external trigger remapping<br>This bit can be set to '1' or '0' by software. It controls the trigger input connected to the external trigger of ADC3 regular conversion.<br>0: ADC3 regular conversion external trigger is connected to EXTI10<br>1: ADC3 regular conversion external trigger is connected to TIM5_CH3  |
| 14        | ADC3_ETRI      | ADC3 injection conversion external trigger remapping<br>This bit can be set to '1' or '0' by software. It controls the trigger input connected to the ADC3 injection conversion external trigger.<br>0: ADC3 injection conversion external trigger is connected to EXTI14<br>1: ADC3 injection conversion external trigger is connected to TIM5_CH4   |
| 13        | Reserved       | Reserved, the reset value must be maintained.   |
| 12        | COMP7_RMP      | Remapping of COMP7_OUT<br>This bit can be set to '1' or '0' by software.<br>0: No remapping (COMP7_OUT/PC2);<br>1: Remapping (COMP7_OUT/PD12).  |
| 11:10     | COMP6_RMP[1:0] | Remapping of COMP6_OUT<br>This bit can be set to '1' or '0' by software.<br>00: No remapping (COMP6_OUT/PC9);<br>01: Remapping (COMP6_OUT/PA12);  |

| Bit field | Name           | Description   |
|-----------|----------------|---|
|           |                | 10: Unused combination;<br>11: Remapping (COMP6_OUT/PB7).   |
| 9:8       | COMP5_RMP[1:0] | Remapping of COMP5_OUT<br>This bit can be set to '1' or '0' by software.<br>00: No remapping (COMP5_OUT/PB0);<br>01: Remapping (COMP5_OUT/PB11);<br>10: Remapping (COMP5_OUT/PB6);<br>11: Remapping (COMP5_OUT/PA11). |
| 7:6       | COMP4_RMP[1:0] | Remapping of COMP4_OUT<br>This bit can be set to '1' or '0' by software.<br>00: No remapping (COMP4_OUT/PC5);<br>01: Remapping (COMP4_OUT/PB12);<br>10: Unused combination;<br>11: Remapping (COMP4_OUT/PC11).        |
| 5:4       | COMP3_RMP[1:0] | Remapping of COMP3_OUT<br>This bit can be set to '1' or '0' by software.<br>00: No remapping (COMP3_OUT/PB10);<br>01: Remapping (COMP3_OUT/PC10);<br>10: Unused combination;<br>11: Remapping (COMP3_OUT/PA2).        |
| 3:2       | COMP2_RMP[1:0] | Remapping of COMP2_OUT<br>This bit can be set to '1' or '0' by software.<br>00: No remapping (COMP2_OUT/PA6);<br>01: Remapping (COMP2_OUT/PA7);<br>10: Remapping (COMP2_OUT/PA12);<br>11: Remapping (COMP2_OUT/PB9).  |
| 1:0       | COMP1_RMP[1:0] | Remapping of COMP1_OUT<br>This bit can be set to '1' or '0' by software.<br>00: No remapping (COMP1_OUT/PA0);<br>01: Remapping (COMP1_OUT/PB1);<br>10: Remapping (COMP1_OUT/PA11);<br>11: Remapping (COMP1_OUT/PB8).  |

### 7.4.10 AFIO alternate remapping configuration register 5(AFIO\_RMP\_CFG5)

Address offset: 0x28

Reset value: 0x0000 0000

|          |         |         |         |         |         |         |         |         |         |         |         |         |         |         |         |         |         |         |         |         |         |         |         |         |         |         |         |         |    |   |  |
|----------|---------|---------|---------|---------|---------|---------|---------|---------|---------|---------|---------|---------|---------|---------|---------|---------|---------|---------|---------|---------|---------|---------|---------|---------|---------|---------|---------|---------|----|---|--|
| 31       |         |         |         | 24      |         |         |         | 23      |         | 22      |         | 21      |         | 20      |         | 19      |         | 18      |         | 17      |         | 16      |         |         |         |         |         |         |    |   |  |
| Reserved |         |         |         |         |         |         |         |         |         | EGB4    | EGB3    | EGB2    | EGB1    | EGBN4   | EGBN3   | EGBN2   | EGBN1   |         |         |         |         |         |         |         |         |         |         |         |    |   |  |
|          |         |         |         |         |         |         |         |         |         | _DET_EN | _DET_EN | _DET_EN | _DET_EN | _DET_EN | _DET_EN | _DET_EN | _DET_EN |         |         |         |         |         |         |         |         |         |         |         |    |   |  |
|          |         |         |         |         |         |         |         |         |         | rw      | rw      | rw      | rw      | rw      | rw      | rw      | rw      |         |         |         |         |         |         |         |         |         |         |         |    |   |  |
| 15       |         | 14      |         | 13      |         | 12      |         | 11      |         | 10      |         | 9       |         | 8       |         | 7       |         | 6       |         | 5       |         | 4       |         | 3       |         | 2       |         | 1       |    | 0 |  |
| ECLAMP4  | ECLAMP3 | ECLAMP2 | ECLAMP1 | EGB4    | EGB3    | EGB2    | EGB1    | EGBN4   | EGBN3   | EGBN2   | EGBN1   | ECLAMP4 | ECLAMP3 | ECLAMP2 | ECLAMP1 |         |         |         |         |         |         |         |         |         |         |         |         |         |    |   |  |
| _DET_EN  | _DET_EN | _DET_EN | _DET_EN | _RST_EN | _RST_EN | _RST_EN | _RST_EN | _RST_EN | _RST_EN | _RST_EN | _RST_EN | _RST_EN | _RST_EN | _RST_EN | _RST_EN | _RST_EN | _RST_EN | _RST_EN | _RST_EN | _RST_EN | _RST_EN | _RST_EN | _RST_EN | _RST_EN | _RST_EN | _RST_EN | _RST_EN | _RST_EN |    |   |  |
| rw       | rw      | rw      | rw      | rw      | rw      | rw      | rw      | rw      | rw      | rw      | rw      | rw      | rw      | rw      | rw      | rw      | rw      | rw      | rw      | rw      | rw      | rw      | rw      | rw      | rw      | rw      | rw      | rw      | rw |   |  |

| Bit field | Name           | Description   |
|-----------|----------------|---|
| 31:24     | Reserved       | Reserved, the reset value must be maintained.   |
| 23        | EGB4_DET_EN    | EMC GB4 detection enable bit (ground bounce detection).<br>0: Disable<br>1: Enable    |
| 22        | EGB3_DET_EN    | EMC GB3 detection enable bit.<br>0: Disable<br>1: Enable                              |
| 21        | EGB2_DET_EN    | EMC GB2 detection enable bit.<br>0: Disable<br>1: Enable                              |
| 20        | EGB1_DET_EN    | EMC GB1 detection enable bit.<br>0: Disable<br>1: Enable                              |
| 19        | EGBN4_DET_EN   | EMC GBN4 detection enable bit.<br>0: Disable<br>1: Enable                             |
| 18        | EGBN3_DET_EN   | EMC GBN3 detection enable bit.<br>0: Disable<br>1: Enable                             |
| 17        | EGBN2_DET_EN   | EMC GBN2 detection enable bit.<br>0: Disable<br>1: Enable                             |
| 16        | EGBN1_DET_EN   | EMC GBN1 detection enable bit.<br>0: Disable<br>1: Enable                             |
| 15        | ECLAMP4_DET_EN | EMC CLAMP4 detection enable bit for VDD_4.<br>0: Disable<br>1: Enable                 |
| 14        | ECLAMP3_DET_EN | EMC CLAMP3 detection enable bit for VDD_3.<br>0: Disable<br>1: Enable                 |
| 13        | ECLAMP2_DET_EN | EMC CLAMP2 detection enable bit for VDD_2.<br>0: Disable<br>1: Enable                 |
| 12        | ECLAMP1_DET_EN | EMC CLAMP1 detection enable bit for VDD_1.<br>0: Disable<br>1: Enable                 |
| 11        | EGB4_RST_EN    | When EMC GB4 detects it, the system resets the enable bit.<br>0: Disable<br>1: Enable |
| 10        | EGB3_RST_EN    | When EMC GB3 detects it, the system resets the enable bit.<br>0: Disable<br>1: Enable |

| Bit field | Name           | Description  |
|-----------|----------------|--|
| 9         | EGB2_RST_EN    | When EMC GB2 detects it, the system resets the enable bit.<br>0: Disable<br>1: Enable    |
| 8         | EGB1_RST_EN    | When EMC GB1 detects it, the system resets the enable bit.<br>0: Disable<br>1: Enable    |
| 7         | EGBN4_RST_EN   | When EMC GBN4 detects it, the system resets the enable bit.<br>0: Disable<br>1: Enable   |
| 6         | EGBN3_RST_EN   | When EMC GBN3 detects it, the system resets the enable bit.<br>0: Disable<br>1: Enable   |
| 5         | EGBN2_RST_EN   | When EMC GBN2 is detected, the system resets the enable bit.<br>0: Disable<br>1: Enable  |
| 4         | EGBN1_RST_EN   | When EMC GBN1 is detected, the system resets the enable bit.<br>0: Disable<br>1: Enable  |
| 3         | ECLAMP4_RST_EN | When EMC CLAMP4 detects it, the system resets the enable bit.<br>0: Disable<br>1: Enable |
| 2         | ECLAMP3_RST_EN | When EMC CLAMP3 detects, the system resets the enable bit.<br>0: Disable<br>1: Enable    |
| 1         | ECLAMP2_RST_EN | When EMC CLAMP2 detects, the system resets the enable bit.<br>0: Disable<br>1: Enable    |
| 0         | ECLAMP1_RST_EN | When EMC CLAMP1 detects, the system resets the enable bit.<br>0: Disable<br>1: Enable    |

## 8 DMA controller

### 8.1 Introduction

The DMA controller can access totally 8 AHB slaves: Flash, SRAM, ADC, SDIO, QSPI, ETH, APB1 and APB2. DMA Controller is controlled by CPU to perform fast data movement from source to destination. After configuration, data can be transferred without CPU intervention. Thus, CPU can be released for other computation/control tasks or save overall system power consumption.

The chip has two DMA (DMA1, DMA2) controllers, and each DMA controller has 8 logical channels. Each logic channel is to serve memory access requests from single or multiple peripherals. Internal arbiter controls the priority of different DMA channels.

### 8.2 Main features

- 16 independently configurable DMA channels: 8 channels each for DMA1 and DMA2.
- Support three transfer types which are Memory-to-Memory, Memory-to-Peripheral and Peripheral-to-Memory.
- Each DMA channel supports hardware requests and software triggers to initiate transfer, and is configured by software.
- Each DMA channel has dedicated software priority level (DMA\_CHCFGx.PRIOLVL [1:0] bits, corresponding to 4 levels of priority) which can be configured individually. Channels with the same software priority level will further compare hardware index (channel number) to decide final priority (lower index number channel will has higher priority).
- Configurable source and destination size. Address setting should correspond to data size.
- Configurable circular transfer mode for each channel.
- Each channel has 3 independent event flags and interrupts (Transfer complete, Half transfer, Transfer error), and 1 global interrupt flag (set by logical OR of 3 events).
- Access totally 8 AHB slaves: Flash, SRAM, ADC, SDIO, QSPI, ETH, APB1 and APB2.
- Configurable data transmit number (0~65535).

*Note: It is not recommended to use DMA to program the FLASH to avoid timing errors.*

## 8.3 Block diagram

Figure 8-1 DMA block diagram

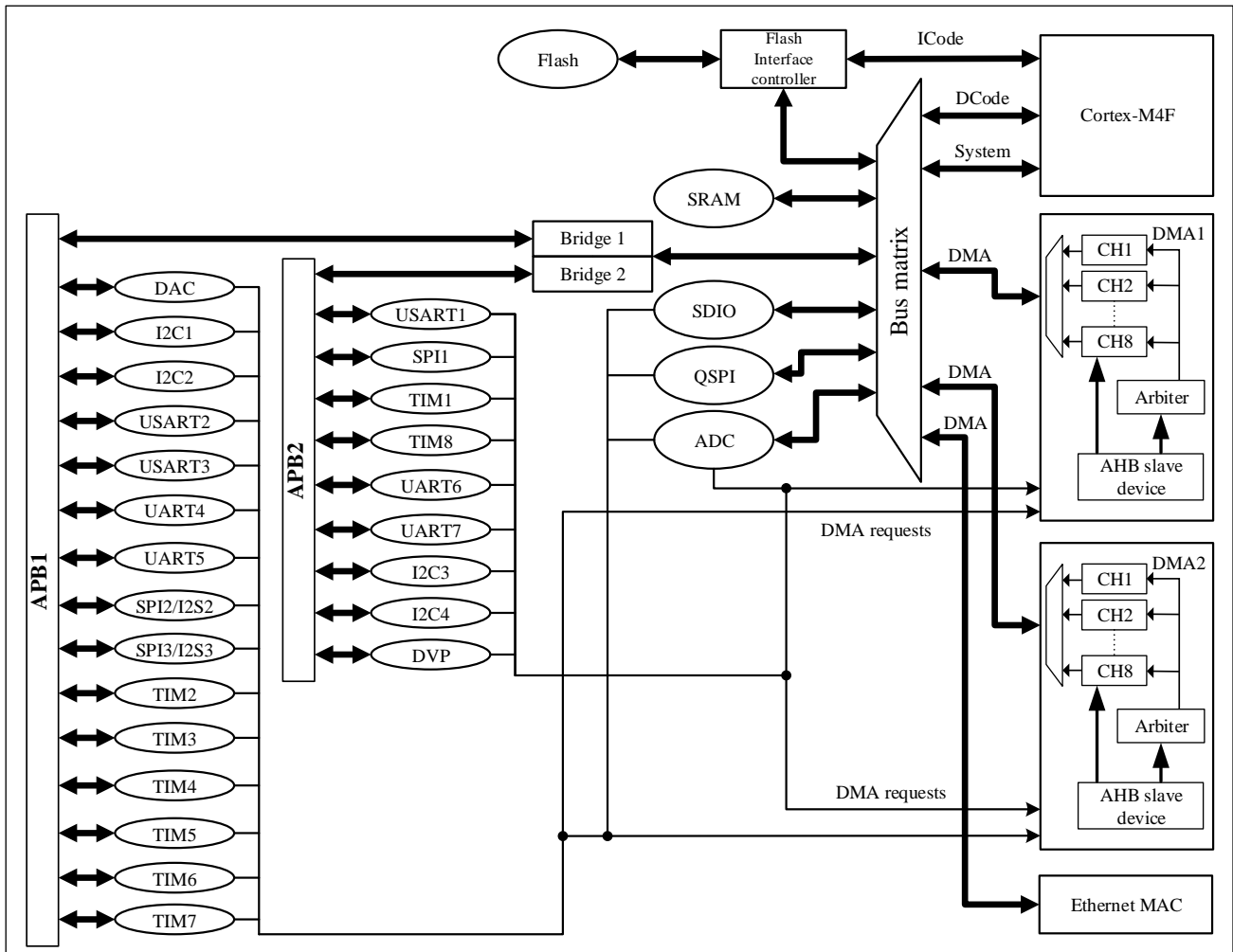

## 8.4 Function description

DMA controller and Cortex™-M4F core share the same system data bus. When CPU and DMA access the same target (RAM or peripheral) at the same time, DMA request will suspend CPU from accessing the system bus for several cycles, and the bus arbiter will perform cyclic scheduling. This allows the CPU to get at least half of the system bus (memory or peripheral) bandwidth.

### 8.4.1 DMA operation

A DMA request can be triggered by hardware peripherals or software, and the DMA controller processes the request according to the priority level of the channel. The data is read from the source address according to the configured transfer address and bit width, and then the read data is stored in the destination address space. After one operation, the controller calculates the number of remaining transfers and updates the source address and the destination address of the next transfer.

Each DMA data transfer consists of three operations:

- Data access: determine the source address (DMA\_PADDRx or DMA\_MADDRx) according to the transfer direction and read data from the source address.
- Data storage: determine the destination address (DMA\_PADDRx or DMA\_MADDRx) according to the transfer direction and store the read data into the destination address space.
- Calculate the number of outstanding operations, perform a decrement operation of the DMA\_TXNUMx register, and update the source and destination addresses of the next operation.

## 8.4.2 Channel priority and arbitration

The DMA uses an arbitration strategy to handle multiple requests from different channels. The priority of each channel is programmable in the channel control register (DMA\_CHCFGx).

4 levels of priority:

- ◆ Very high priority
- ◆ High priority
- ◆ Medium priority
- ◆ Low priority

By default, channel with lower index has higher priority if the programmed priority is the same.

## 8.4.3 DMA channels and number of transfers

Each channel can perform DMA transfer between the peripheral register at the specified address and the memory address. The number of data transferred by DMA is programmable, and the maximum supported value is 65535. The DMA\_TXNUM register is decremented after each transfer.

## 8.4.4 Programmable data bit width

Peripheral and memory transfer data bit width supports byte, half-word and word, which can be programmed through DMA\_CHCFGx.PSIZE and DMA\_CHCFGx.MSIZE.

When DMA\_CHCFGx.PSIZE and DMA\_CHCFGx.MSIZE are different, the DMA module aligns the data according to the Table 8-1 below.

Table 8-1 Programmable data width and endian operation (when PINC = MINC = 1)

| Source width (bit) | Destination width (bit) | Number of transfer (bit) | Source: Address / data | Transfer operations (R: Read, W: Write) | Destination: Address / data |
|--------------------|-------------------------|--------------------------|------------------------|---|-----------------------------|
| 8                  | 8                       | 4                        | 0x0 / B0               | 1: R B0 [7:0] @0x0, W B0 [7:0] @0x0     | 0x0 / B0                    |
|                    |                         |                          | 0x1 / B1               | 2: R B1 [7:0] @0x1, W B1 [7:0] @0x1     | 0x1 / B1                    |
|                    |                         |                          | 0x2 / B2               | 3: R B2 [7:0] @0x2, W B2 [7:0] @0x2     | 0x2 / B2                    |
|                    |                         |                          | 0x3 / B3               | 4: R B3 [7:0] @0x3, W B3 [7:0] @0x3     | 0x3 / B3                    |
| 8                  | 16                      | 4                        | 0x0 / B0               | 1: R B0 [7:0] @0x0, W 00B0 [15:0] @0x0  | 0x0 / 00B0                  |

| Source width (bit) | Destination width (bit) | Number of transfer (bit) | Source: Address / data   | Transfer operations (R: Read,W: Write)   | Destination: Address / data  |
|--------------------|-------------------------|--------------------------|--|--|--|
|                    |                         |                          | 0x1 / B1<br>0x2 / B2<br>0x3 / B3                                     | 2: R B1 [7:0] @0x1, W 00B1 [15:0] @0x2<br>3: R B2 [7:0] @0x2, W 00B2 [15:0] @0x4<br>4: R B3 [7:0] @0x3, W 00B3 [15:0] @0x6   | 0x2 / 00B1<br>0x4 / 00B2<br>0x6 / 00B3                               |
| 8                  | 32                      | 4                        | 0x0 / B0<br>0x1 / B1<br>0x2 / B2<br>0x3 / B3                         | 1: R B0 [7:0] @0x0, W 000000B0 [31:0] @0x0<br>2: R B1 [7:0] @0x1, W 000000B1 [31:0] @0x4<br>3: R B2 [7:0] @0x2, W 000000B2 [31:0] @0x8<br>4: R B3 [7:0] @0x3, W 000000B3 [31:0] @0xC                             | 0x0 / 000000B0<br>0x4 / 000000B1<br>0x8 / 000000B2<br>0xC / 000000B3 |
| 16                 | 8                       | 4                        | 0x0 / B1B0<br>0x2 / B3B2<br>0x4 / B5B4<br>0x6 / B7B6                 | 1: R B1B0 [15:0] @0x0, W B0 [7:0] @0x0<br>2: R B3B2 [15:0] @0x2, W B2 [7:0] @0x1<br>3: R B5B4 [15:0] @0x4, W B4 [7:0] @0x2<br>4: R B7B6 [15:0] @0x6, W B6 [7:0] @0x3   | 0x0 / B0<br>0x1 / B2<br>0x2 / B4<br>0x3 / B6                         |
| 16                 | 16                      | 4                        | 0x0 / B1B0<br>0x2 / B3B2<br>0x4 / B5B4<br>0x6 / B7B6                 | 1: R B1B0 [15:0] @0x0, W B1B0 [15:0] @0x0<br>2: R B3B2 [15:0] @0x2, W B3B2 [15:0] @0x2<br>3: R B5B4 [15:0] @0x4, W B5B4 [15:0] @0x4<br>4: R B7B6 [15:0] @0x6, W B7B6 [15:0] @0x6                                 | 0x0 / B1B0<br>0x2 / B3B2<br>0x4 / B5B4<br>0x6 / B7B6                 |
| 16                 | 32                      | 4                        | 0x0 / B1B0<br>0x2 / B3B2<br>0x4 / B5B4<br>0x6 / B7B6                 | 1: R B1B0 [15:0] @0x0, W 0000B1B0 [31:0] @0x0<br>2: R B3B2 [15:0] @0x2, W 0000B3B2 [31:0] @0x4<br>3: R B5B4 [15:0] @0x4, W 0000B5B4 [31:0] @0x8<br>4: R B7B6 [15:0] @0x6, W 0000B7B6 [31:0] @0xC                 | 0x0 / 0000B1B0<br>0x4 / 0000B3B2<br>0x8 / 0000B5B4<br>0xC / 0000B7B6 |
| 32                 | 8                       | 4                        | 0x0 / B3B2B1B0<br>0x4 / B7B6B5B4<br>0x8 / BBBAB9B8<br>0xC / BFBEBDBC | 1: R B3B2B1B0 [31:0] @0x0, W B0 [7:0] @0x0<br>2: R B7B6B5B4 [31:0] @0x4, W B4 [7:0] @0x1<br>3: R BBBAB9B8 [31:0] @0x8, W B8 [7:0] @0x2<br>4: R BFBEBDBC [31:0] @0xC, W BC [7:0] @0x3                             | 0x0 / B0<br>0x1 / B4<br>0x2 / B8<br>0x3 / BC                         |
| 32                 | 16                      | 4                        | 0x0 / B3B2B1B0<br>0x4 / B7B6B5B4<br>0x8 / BBBAB9B8<br>0xC / BFBEBDBC | 1: R B3B2B1B0 [31:0] @0x0, W B1B0 [15:0] @0x0<br>2: R B7B6B5B4 [31:0] @0x4, W B5B4 [15:0] @0x2<br>3: R BBBAB9B8 [31:0] @0x8, W B9B8 [15:0] @0x4<br>4: R BFBEBDBC [31:0] @0xC, W BDBC [15:0] @0x6                 | 0x0 / B1B0<br>0x2 / B5B4<br>0x4 / B9B8<br>0x6 / BDBC                 |
| 32                 | 32                      | 4                        | 0x0 / B3B2B1B0<br>0x4 / B7B6B5B4<br>0x8 / BBBAB9B8<br>0xC / BFBEBDBC | 1: R B3B2B1B0 [31:0] @0x0, W B3B2B1B0 [31:0] @0x0<br>2: R B7B6B5B4 [31:0] @0x4, W B7B6B5B4 [31:0] @0x4<br>3: R BBBAB9B8 [31:0] @0x8, W BBBAB9B8 [31:0] @0x8<br>4: R BFBEBDBC [31:0] @0xC, W BFBEBDBC [31:0] @0xC | 0x0 / B3B2B1B0<br>0x4 / B7B6B5B4<br>0x8 / BBBAB9B8<br>0xC / BFBEBDBC |

Note:

DMA always provide full 32-bits data to HWDATA[31:0] no matter what destination size it is (HSIZE still follows destination size setting for device supports byte/half-word operation). The HWDATA[31:0] it provides follow rules as follow:

- When source size is smaller than destination size, DMA pads the MSB with 0 until their sizes match and duplicates it to be 32 bits. E.g., source is 8 bits data 0x55 and destination size is 16 bits. DMA pads the source data with 0 to make it 16 bits and become 0x0055, then duplicate it to 32-bit data 0x0055\_0055 and provide to HWDATA[31:0]; (if destination size is 32-bit then DMA will only pad source data with 0).

- When source size is larger or equal to destination size and smaller than 32 bits, DMA duplicates source data to 32 bits data. E.g., source data is 8 bits data 0x1F, HWDATA[31:0] = 0x1F1F\_1F1F. if source data is 16 bits data 0x2345, then HWDATA[31:0] = 0x2345\_2345.

This guarantees peripherals that only support word operation won't generate bus error and the desired data can still move to the place we want with extra bits i.e. 0 padding. If user wants to configure an 8-bit register but is aligned to a 32-bit address boundary, the source size should be set to 8 bits and destination to 32 bits so extra bits will be padded with 0.

### 8.4.5 Peripheral/Memory address incrementation

DMA\_CHCFGx.PINC and DMA\_CHCFGx.MINC respectively control whether the peripheral address and memory address are enabled in auto-increment mode. The software cannot (can read) write the address register during transfer.

- In auto-increment mode, the next address to be transferred is automatically increased according to the data bit width (1, 2 or 4) after each transfer. The address of the first transfer is stored in DMA\_PADDRx or DMA\_MADDRx register.
- In fixed mode, the address is always fixed to the initial address.

At the end of transfer (i.e. the transfer count changes to 0), different processes will be carried out according to whether the current work is under circular mode or not.

- In acyclic mode, DMA stops after the transfer is completed. To start a new DMA transfer, need to rewrite the transfer number in the DMA\_TXNUMx register with the DMA channel disabled.
- In circular mode, at the end of a transfer, the content of the DMA\_TXNUMx register will be automatically reloaded to its initial value, and the current internal peripheral or memory address register will also be reloaded to the initial base address set by the DMA\_PADDRx or DMA\_MADDRx register.

### 8.4.6 Channel configuration procedure

The detail configuration flow is as below:

1. Configure interrupt mask bits, 1: enable interrupts, 0 disable interrupts.
2. Configure channel peripheral address and memory address and transfer direction.
3. Configure channel priority, 0: lowest, 3: highest.
4. Configure peripheral and memory address increment.
5. Configure channel transfer block size.
6. If necessary, configure circular mode.
7. If it is memory to memory, configure MEM2MEM mode.
8. Repeat step 1~8 on channel 1~8.
9. Enable corresponding channel.

If software is used to serve interrupt, software must enquire interrupt status register to check which interrupt occurred (software needs to write 1 to interrupt flag clear bit to clear the corresponding interrupt). Before enable channel, all interrupts corresponding to the channel should be cleared.

If the interrupt is transfer complete interrupt, software can configure the next transfer, or report to user this channel transformation is done.

*Note: Due to DMA user permission management, DMA configuration and enable must occur within the same user program area.*

## 8.4.7 Flow control

Three major flow controls are supported:

- Memory to memory
- Memory to peripheral
- Peripheral to memory

Flow control is controlled by two register bits in each DMA channel configuration register. Flow control is used to control source/destination and direction of DMA channel.

Table 8-2 Flow control table

| DMA_CHCFGx.MEM2MEM | DMA_CHCFGx.DIR | Source         | Destination    | Transfer   |
|--------------------|----------------|----------------|----------------|--|
| 1                  | x              | Memory         | Memory         | AHB read to AHB write, can do back2back transfer |
| 0                  | 1              | Memory         | AHB Peripheral | AHB read to AHB write, single transfer           |
|                    |                |                | APB Peripheral | AHB read to APB write, single transfer           |
| 0                  | 0              | AHB Peripheral | Memory         | AHB read to AHB write, single transfer           |
|                    |                | APB Peripheral |                | APB read to AHB write, single transfer           |

## 8.4.8 Circular mode

The circular mode is used to process circular buffers and continuous data transmission (such as ADC scan mode). The DMA\_CHCFGx.CIRC is used to enable this function. When the circular mode is activated, if the number of data to be transferred becomes 0, it will automatically be restored to the initial value when configuring the channel, and the DMA operation will continue.

If the user wants to turn off the circular mode, the user needs to write 0 to DMA\_CHCFGx.CHEN to disable the DMA channel, and then write 0 to DMA\_CHCFGx.CIRC (when DMA\_CHCFGx.CHEN is 1, other bits in the DMA\_CHCFGx register cannot be rewritten).

## 8.4.9 Error management

DMA access to a reserved address area will cause DMA transmission errors. When an error occurs, the transfer error flag is set, and the hardware automatically clears the current DMA channel enable bit (DMA\_CHCFGx.CHEN), and the channel operation is stopped. If the transfer error interrupt enable bit is set in the DMA\_CHCFGx register, an interrupt will be generated.

## 8.4.10 Interrupt

- Transfer complete interrupt:

An interrupt is generated when channel data transfer is complete. Interrupt is a level signal. Each channel has its dedicated interrupt, interrupt mask control and interrupt status bit. interrupt status bit is cleared when interrupt flag clear bit is set.

- Half transfer interrupt:

An interrupt is generated when half of the channel data is transferred. Interrupt is a level signal. Each channel has its dedicated interrupt, interrupt mask control and interrupt status bit. interrupt status bit is cleared when interrupt flag clear bit is set.

- Transfer error interrupt:

An interrupt is generated when bus returned error. Interrupt is a level signal. Each channel has its dedicated interrupt, interrupt mask control and interrupt status bit. interrupt status bit is cleared when interrupt flag clear bit is set.

Table 8-3 DMA interrupt request

| Interrupt event   | Event flag bit | Enable control bit |
|-------------------|----------------|--------------------|
| Half transfer     | HTXF           | HTXIE              |
| Transfer complete | TXCF           | TXCIE              |
| Transfer error    | ERRF           | ERRIE              |

## 8.4.11 DMA request mapping

### 8.4.11.1 DMA1 controller

The DMA1 request mapping is shown in the following figure. By configuring the registers of the corresponding peripherals, the DMA requests of each peripheral can be turned on or off independently, and according to the channel priority, only one request is valid at the same time.

Figure 8-2 DMA1 request mapping

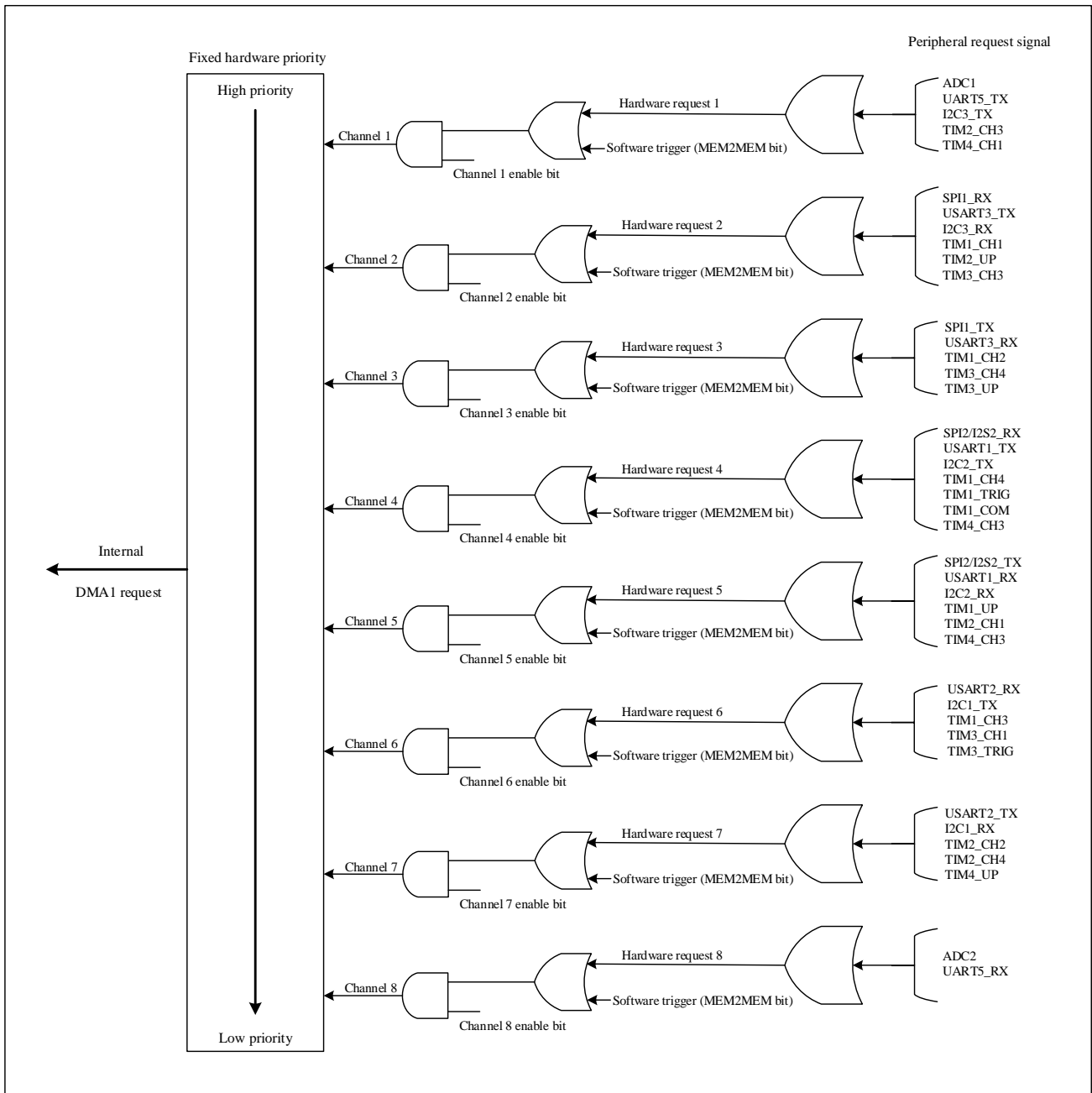

Table 8-4 DMA1 request mapping table for each channel

| Peripheral | Channel 1 | Channel 2 | Channel 3 | Channel 4                         | Channel 5    | Channel 6 | Channel 7 | Channel 8 |
|------------|-----------|-----------|-----------|-----------------------------------|--------------|-----------|-----------|-----------|
| ADC        | ADC1      | -         | -         | -                                 | -            | -         | -         | ADC2      |
| SPI/I2S    | -         | SPI1_RX   | SPI1_TX   | SPI2/I2S2_RX                      | SPI2/I2S2_TX | -         | -         | -         |
| USART      | UART5_TX  | USART3_TX | USART3_RX | USART1_TX                         | USART1_RX    | USART2_RX | USART2_TX | UART5_RX  |
| I2C        | I2C3_TX   | I2C3_RX   |           | I2C2_TX                           | I2C2_RX      | I2C1_TX   | I2C1_RX   |           |
| TIM1       | -         | TIM1_CH1  | TIM1_CH2  | TIM1_CH4<br>TIM1_TRIG<br>TIM1_COM | TIM1_UP      | TIM1_CH3  | -         | -         |
| TIM2       | TIM2_CH3  | TIM2_UP   | -         | -                                 | TIM2_CH1     | -         | TIM2_CH2  | -         |

| Peripheral | Channel 1 | Channel 2 | Channel 3           | Channel 4 | Channel 5 | Channel 6             | Channel 7 | Channel 8 |
|------------|-----------|-----------|---------------------|-----------|-----------|-----------------------|-----------|-----------|
|            |           |           |                     |           |           |                       | TIM2_CH4  |           |
| TIM3       | -         | TIM3_CH3  | TIM3_CH4<br>TIM3_UP | -         | -         | TIM3_CH1<br>TIM3_TRIG | -         | -         |
| TIM4       | TIM4_CH1  | -         | -                   | TIM4_CH2  | TIM4_CH3  | -                     | TIM4_UP   | -         |

*Note: Different DMA channels cannot use the same request source, otherwise only high priority channels will be triggered if multiple channels are enabled.*

#### **8.4.11.2 DMA2 controller**

The DMA2 request mapping is shown in the following figure. By configuring the registers of the corresponding peripherals, the DMA requests of each peripheral can be turned on or off independently, and according to the channel priority, only one request is valid at the same time.

Figure 8-3 DMA2 request mapping

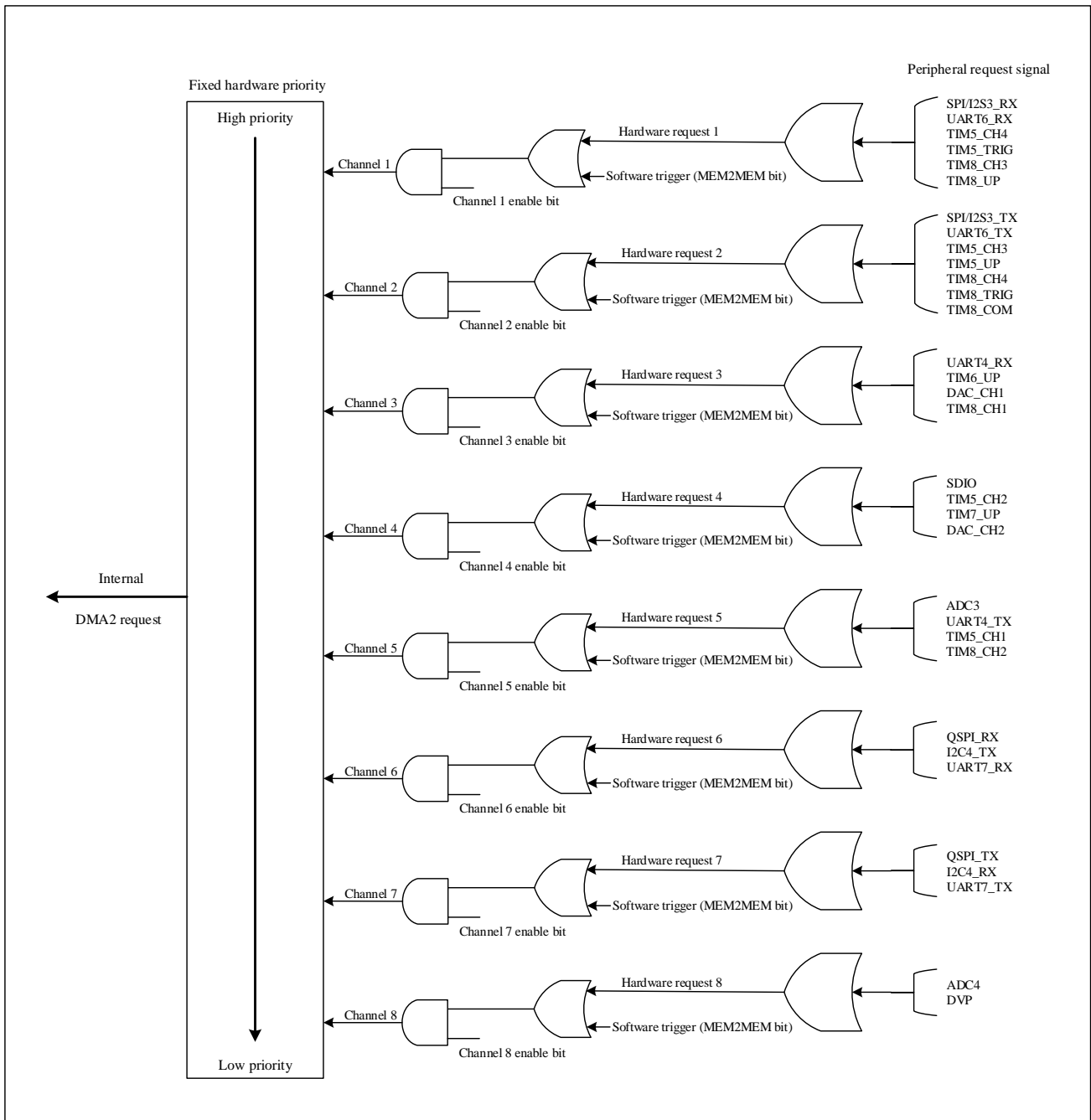

Table 8-5 DMA2 request mapping table for each channel

| Peripheral | Channel 1             | Channel 2           | Channel 3 | Channel 4 | Channel 5 | Channel 6 | Channel 7 | Channel 8 |
|------------|-----------------------|---------------------|-----------|-----------|-----------|-----------|-----------|-----------|
| ADC        | -                     | -                   | -         | -         | ADC3      | -         | -         | ADC4      |
| SPI/I2S    | SPI3/I2S3_RX          | SPI3/I2S3_TX        | -         | -         | -         | QSPI_RX   | QSPI_TX   | -         |
| I2C4       | -                     | -                   | -         | -         | -         | I2C4_TX   | I2C4_RX   | -         |
| UART       | UART6_RX              | UART6_TX            | UART4_RX  | -         | UART4_TX  | UART7_RX  | UART7_TX  | -         |
| SDIO       | -                     | -                   | -         | SDIO      | -         | -         | -         | -         |
| TIM5       | TIM5_CH4<br>TIM5_TRIG | TIM5_CH3<br>TIM5_UP | -         | TIM5_CH2  | TIM5_CH1  | -         | -         | -         |

| Peripheral | Channel 1           | Channel 2                         | Channel 3          | Channel 4          | Channel 5 | Channel 6 | Channel 7 | Channel 8 |
|------------|---------------------|-----------------------------------|--------------------|--------------------|-----------|-----------|-----------|-----------|
| TIM6/DAC   | -                   | -                                 | TIM6_UP<br>DAC_CH1 | -                  | -         | -         | -         | -         |
| TIM7/DAC   | -                   | -                                 | -                  | TIM7_UP<br>DAC_CH2 | -         | -         | -         | -         |
| TIM8       | TIM8_CH3<br>TIM8_UP | TIM8_CH4<br>TIM8_TRIG<br>TIM8_COM | TIM8_CH1           | -                  | TIM8_CH2  | -         | -         | -         |
| DVP        | -                   | -                                 | -                  | -                  | -         | -         | -         | DVP       |

Note: Different DMA channels cannot use the same request source, otherwise only high priority channels will be triggered if multiple channels are enabled.

## 8.5 DMA registers

DMA1 base address: 0x4002\_0000;

DMA2 base address: 0x4002\_0400.

### 8.5.1 DMA register overview

Table 8-6 DMA register overview

| Offset | Register    | 31         | 30     | 29     | 28     | 27     | 26     | 25     | 24     | 23     | 22     | 21     | 20     | 19     | 18     | 17     | 16         | 15     | 14      | 13            | 12     | 11         | 10     | 9          | 8      | 7           | 6      | 5      | 4      | 3      | 2      | 1      | 0      |   |   |   |   |   |   |   |
|--------|-------------|------------|--------|--------|--------|--------|--------|--------|--------|--------|--------|--------|--------|--------|--------|--------|------------|--------|---------|---------------|--------|------------|--------|------------|--------|-------------|--------|--------|--------|--------|--------|--------|--------|---|---|---|---|---|---|---|
| 000h   | DMA_INTSTS  | ERRF8      | HTXF8  | TXCF8  | GLBF8  | ERRF7  | HTXF7  | TXCF7  | GLBF7  | ERRF6  | HTXF6  | TXCF6  | GLBF6  | ERRF5  | HTXF5  | TXCF5  | GLBF5      | ERRF4  | HTXF4   | TXCF4         | GLBF4  | ERRF3      | HTXF3  | TXCF3      | GLBF3  | ERRF2       | HTXF2  | TXCF2  | GLBF2  | ERRF1  | HTXF1  | TXCF1  | GLBF1  |   |   |   |   |   |   |   |
|        | Reset Value | 0          | 0      | 0      | 0      | 0      | 0      | 0      | 0      | 0      | 0      | 0      | 0      | 0      | 0      | 0      | 0          | 0      | 0       | 0             | 0      | 0          | 0      | 0          | 0      | 0           | 0      | 0      | 0      | 0      | 0      | 0      | 0      |   |   |   |   |   |   |   |
| 004h   | DMA_INTCLR  | CERRF8     | CHTXF8 | CTXCF8 | CGLBF8 | CERRF7 | CHTXF7 | CTXCF7 | CGLBF7 | CERRF6 | CHTXF6 | CTXCF6 | CGLBF6 | CERRF5 | CHTXF5 | CTXCF5 | CGLBF5     | CERRF4 | CHTXF4  | CTXCF4        | CGLBF4 | CERRF3     | CHTXF3 | CTXCF3     | CGLBF3 | CERRF2      | CHTXF2 | CTXCF2 | CGLBF2 | CERRF1 | CHTXF1 | CTXCF1 | CGLBF1 |   |   |   |   |   |   |   |
|        | Reset Value | 0          | 0      | 0      | 0      | 0      | 0      | 0      | 0      | 0      | 0      | 0      | 0      | 0      | 0      | 0      | 0          | 0      | 0       | 0             | 0      | 0          | 0      | 0          | 0      | 0           | 0      | 0      | 0      | 0      | 0      | 0      | 0      |   |   |   |   |   |   |   |
| 008h   | DMA_CHCFG1  | Reserved   |        |        |        |        |        |        |        |        |        |        |        |        |        |        |            |        | MEM2MEM | PRIOL.VL[1:0] |        | MSIZE[1:0] |        | PSIZE[1:0] |        | MINC        | PINC   | CIRC   | DIR    | ERRIE  | HTXIE  | TXCIE  | CHEN   |   |   |   |   |   |   |   |
|        | Reset Value | 0          |        |        |        |        |        |        |        |        |        |        |        |        |        |        |            |        | 0       | 0             | 0      | 0          | 0      | 0          | 0      | 0           | 0      | 0      | 0      | 0      | 0      | 0      | 0      | 0 | 0 | 0 | 0 | 0 | 0 |   |
| 00Ch   | DMA_TXNUM1  | Reserved   |        |        |        |        |        |        |        |        |        |        |        |        |        |        | NDTX[15:0] |        |         |               |        |            |        |            |        |             |        |        |        |        |        |        |        |   |   |   |   |   |   |   |
|        | Reset Value | 0          |        |        |        |        |        |        |        |        |        |        |        |        |        |        | 0          | 0      | 0       | 0             | 0      | 0          | 0      | 0          | 0      | 0           | 0      | 0      | 0      | 0      | 0      | 0      | 0      | 0 | 0 | 0 | 0 | 0 | 0 | 0 |
| 010h   | DMA_PADDR1  | ADDR[31:0] |        |        |        |        |        |        |        |        |        |        |        |        |        |        |            |        |         |               |        |            |        |            |        |             |        |        |        |        |        |        |        |   |   |   |   |   |   |   |
|        | Reset Value | 0          | 0      | 0      | 0      | 0      | 0      | 0      | 0      | 0      | 0      | 0      | 0      | 0      | 0      | 0      | 0          | 0      | 0       | 0             | 0      | 0          | 0      | 0          | 0      | 0           | 0      | 0      | 0      | 0      | 0      | 0      | 0      |   |   |   |   |   |   |   |
| 014h   | DMA_MADDR1  | ADDR[31:0] |        |        |        |        |        |        |        |        |        |        |        |        |        |        |            |        |         |               |        |            |        |            |        |             |        |        |        |        |        |        |        |   |   |   |   |   |   |   |
|        | Reset Value | 0          | 0      | 0      | 0      | 0      | 0      | 0      | 0      | 0      | 0      | 0      | 0      | 0      | 0      | 0      | 0          | 0      | 0       | 0             | 0      | 0          | 0      | 0          | 0      | 0           | 0      | 0      | 0      | 0      | 0      | 0      | 0      |   |   |   |   |   |   |   |
| 018h   | DMA_CHSEL1  | Reserved   |        |        |        |        |        |        |        |        |        |        |        |        |        |        |            |        |         |               |        |            |        |            |        | CH_SEL[5:0] |        |        |        |        |        |        |        |   |   |   |   |   |   |   |
|        | Reset Value | 0          |        |        |        |        |        |        |        |        |        |        |        |        |        |        |            |        |         |               |        |            |        |            |        | 0           | 0      | 0      | 0      | 0      | 0      |        |        |   |   |   |   |   |   |   |
| 01Ch   | DMA_CHCFG2  | Reserved   |        |        |        |        |        |        |        |        |        |        |        |        |        |        |            |        | MEM2MEM | PRIOL.VL[1:0] |        | MSIZE[1:0] |        | PSIZE[1:0] |        | MINC        | PINC   | CIRC   | DIR    | ERRIE  | HTXIE  | TXCIE  | CHEN   |   |   |   |   |   |   |   |
|        | Reset Value | 0          |        |        |        |        |        |        |        |        |        |        |        |        |        |        |            |        | 0       | 0             | 0      | 0          | 0      | 0          | 0      | 0           | 0      | 0      | 0      | 0      | 0      | 0      | 0      | 0 |   |   |   |   |   |   |
| 020h   | DMA_TXNUM2  | Reserved   |        |        |        |        |        |        |        |        |        |        |        |        |        |        | NDTX[15:0] |        |         |               |        |            |        |            |        |             |        |        |        |        |        |        |        |   |   |   |   |   |   |   |
|        | Reset Value | 0          |        |        |        |        |        |        |        |        |        |        |        |        |        |        | 0          | 0      | 0       | 0             | 0      | 0          | 0      | 0          | 0      | 0           | 0      | 0      | 0      | 0      | 0      | 0      | 0      | 0 | 0 | 0 | 0 | 0 | 0 | 0 |
| 024h   | DMA_PADDR2  | ADDR[31:0] |        |        |        |        |        |        |        |        |        |        |        |        |        |        |            |        |         |               |        |            |        |            |        |             |        |        |        |        |        |        |        |   |   |   |   |   |   |   |
|        | Reset Value | 0          | 0      | 0      | 0      | 0      | 0      | 0      | 0      | 0      | 0      | 0      | 0      | 0      | 0      | 0      | 0          | 0      | 0       | 0             | 0      | 0          | 0      | 0          | 0      | 0           | 0      | 0      | 0      | 0      | 0      | 0      | 0      |   |   |   |   |   |   |   |
| 028h   | DMA_MADDR2  | ADDR[31:0] |        |        |        |        |        |        |        |        |        |        |        |        |        |        |            |        |         |               |        |            |        |            |        |             |        |        |        |        |        |        |        |   |   |   |   |   |   |   |
|        | Reset Value | 0          | 0      | 0      | 0      | 0      | 0      | 0      | 0      | 0      | 0      | 0      | 0      | 0      | 0      | 0      | 0          | 0      | 0       | 0             | 0      | 0          | 0      | 0          | 0      | 0           | 0      | 0      | 0      | 0      | 0      | 0      | 0      |   |   |   |   |   |   |   |
| 02Ch   | DMA_CHSEL2  | Reserved   |        |        |        |        |        |        |        |        |        |        |        |        |        |        |            |        |         |               |        |            |        |            |        | CH_SEL[5:0] |        |        |        |        |        |        |        |   |   |   |   |   |   |   |
|        | Reset Value | 0          |        |        |        |        |        |        |        |        |        |        |        |        |        |        |            |        |         |               |        |            |        |            |        | 0           | 0      | 0      | 0      | 0      | 0      |        |        |   |   |   |   |   |   |   |
| 030h   | DMA_CHCFG3  | Reserved   |        |        |        |        |        |        |        |        |        |        |        |        |        |        |            |        | MEM2MEM | PRIOL.VL[1:0] |        | MSIZE[1:0] |        | PSIZE[1:0] |        | MINC        | PINC   | CIRC   | DIR    | ERRIE  | HTXIE  | TXCIE  | CHEN   |   |   |   |   |   |   |   |
|        | Reset Value | 0          |        |        |        |        |        |        |        |        |        |        |        |        |        |        |            |        | 0       | 0             | 0      | 0          | 0      | 0          | 0      | 0           | 0      | 0      | 0      | 0      | 0      | 0      | 0      | 0 |   |   |   |   |   |   |

| Offset | Register    | 31         | 30 | 29 | 28 | 27 | 26 | 25 | 24 | 23 | 22 | 21 | 20 | 19 | 18 | 17 | 16         | 15           | 14          | 13         | 12   | 11   | 10   | 9   | 8     | 7           | 6     | 5    | 4 | 3 | 2 | 1 | 0 |   |   |   |   |   |   |   |   |   |   |   |   |   |   |   |
|--------|-------------|------------|----|----|----|----|----|----|----|----|----|----|----|----|----|----|------------|--------------|-------------|------------|------|------|------|-----|-------|-------------|-------|------|---|---|---|---|---|---|---|---|---|---|---|---|---|---|---|---|---|---|---|---|
| 034h   | Reset Value | Reserved   |    |    |    |    |    |    |    |    |    |    |    |    |    |    | 0          | 0            | 0           | 0          | 0    | 0    | 0    | 0   | 0     | 0           | 0     | 0    | 0 | 0 | 0 | 0 | 0 | 0 | 0 | 0 | 0 | 0 | 0 | 0 | 0 | 0 | 0 | 0 | 0 | 0 | 0 | 0 |
|        | DMA_TXNUM3  | Reserved   |    |    |    |    |    |    |    |    |    |    |    |    |    |    | NDTX[15:0] |              |             |            |      |      |      |     |       |             |       |      |   |   |   |   |   |   |   |   |   |   |   |   |   |   |   |   |   |   |   |   |
| 038h   | Reset Value | 0          |    |    |    |    |    |    |    |    |    |    |    |    |    |    |            |              |             |            |      |      |      |     |       |             |       |      |   |   |   |   |   |   |   |   |   |   |   |   |   |   |   |   |   |   |   |   |
|        | DMA_PADDR3  | ADDR[31:0] |    |    |    |    |    |    |    |    |    |    |    |    |    |    |            |              |             |            |      |      |      |     |       |             |       |      |   |   |   |   |   |   |   |   |   |   |   |   |   |   |   |   |   |   |   |   |
| 03Ch   | Reset Value | 0          |    |    |    |    |    |    |    |    |    |    |    |    |    |    |            |              |             |            |      |      |      |     |       |             |       |      |   |   |   |   |   |   |   |   |   |   |   |   |   |   |   |   |   |   |   |   |
|        | DMA_MADDR3  | ADDR[31:0] |    |    |    |    |    |    |    |    |    |    |    |    |    |    |            |              |             |            |      |      |      |     |       |             |       |      |   |   |   |   |   |   |   |   |   |   |   |   |   |   |   |   |   |   |   |   |
| 040h   | Reset Value | Reserved   |    |    |    |    |    |    |    |    |    |    |    |    |    |    |            |              |             |            |      |      |      |     |       | CH_SEL[5:0] |       |      | 0 | 0 | 0 | 0 | 0 | 0 |   |   |   |   |   |   |   |   |   |   |   |   |   |   |
|        | DMA_CHSEL3  | Reserved   |    |    |    |    |    |    |    |    |    |    |    |    |    |    |            |              |             |            |      |      |      |     |       | CH_SEL[5:0] |       |      | 0 | 0 | 0 | 0 | 0 | 0 |   |   |   |   |   |   |   |   |   |   |   |   |   |   |
| 044h   | Reset Value | Reserved   |    |    |    |    |    |    |    |    |    |    |    |    |    |    | MEM2MEM    | PRIOLVL[1:0] | Mysize[1:0] | PSIZE[1:0] | MINC | PINC | CIRC | DIR | ERRIE | HTXIE       | TXCIE | CHEN |   |   |   |   |   |   |   |   |   |   |   |   |   |   |   |   |   |   |   |   |
|        | DMA_CHCFG4  | Reserved   |    |    |    |    |    |    |    |    |    |    |    |    |    |    | MEM2MEM    | PRIOLVL[1:0] | Mysize[1:0] | PSIZE[1:0] | MINC | PINC | CIRC | DIR | ERRIE | HTXIE       | TXCIE | CHEN |   |   |   |   |   |   |   |   |   |   |   |   |   |   |   |   |   |   |   |   |
| 048h   | Reset Value | Reserved   |    |    |    |    |    |    |    |    |    |    |    |    |    |    | NDTX[15:0] |              |             |            |      |      |      |     |       |             |       |      |   |   |   |   |   |   |   |   |   |   |   |   |   |   |   |   |   |   |   |   |
|        | DMA_TXNUM4  | Reserved   |    |    |    |    |    |    |    |    |    |    |    |    |    |    | NDTX[15:0] |              |             |            |      |      |      |     |       |             |       |      |   |   |   |   |   |   |   |   |   |   |   |   |   |   |   |   |   |   |   |   |
| 04Ch   | Reset Value | 0          |    |    |    |    |    |    |    |    |    |    |    |    |    |    |            |              |             |            |      |      |      |     |       |             |       |      |   |   |   |   |   |   |   |   |   |   |   |   |   |   |   |   |   |   |   |   |
|        | DMA_PADDR4  | ADDR[31:0] |    |    |    |    |    |    |    |    |    |    |    |    |    |    |            |              |             |            |      |      |      |     |       |             |       |      |   |   |   |   |   |   |   |   |   |   |   |   |   |   |   |   |   |   |   |   |
| 050h   | Reset Value | 0          |    |    |    |    |    |    |    |    |    |    |    |    |    |    |            |              |             |            |      |      |      |     |       |             |       |      |   |   |   |   |   |   |   |   |   |   |   |   |   |   |   |   |   |   |   |   |
|        | DMA_MADDR4  | ADDR[31:0] |    |    |    |    |    |    |    |    |    |    |    |    |    |    |            |              |             |            |      |      |      |     |       |             |       |      |   |   |   |   |   |   |   |   |   |   |   |   |   |   |   |   |   |   |   |   |
| 054h   | Reset Value | Reserved   |    |    |    |    |    |    |    |    |    |    |    |    |    |    |            |              |             |            |      |      |      |     |       | CH_SEL[5:0] |       |      | 0 | 0 | 0 | 0 | 0 | 0 |   |   |   |   |   |   |   |   |   |   |   |   |   |   |
|        | DMA_CHSEL4  | Reserved   |    |    |    |    |    |    |    |    |    |    |    |    |    |    |            |              |             |            |      |      |      |     |       | CH_SEL[5:0] |       |      | 0 | 0 | 0 | 0 | 0 | 0 |   |   |   |   |   |   |   |   |   |   |   |   |   |   |
| 058h   | Reset Value | Reserved   |    |    |    |    |    |    |    |    |    |    |    |    |    |    | MEM2MEM    | PRIOLVL[1:0] | Mysize[1:0] | PSIZE[1:0] | MINC | PINC | CIRC | DIR | ERRIE | HTXIE       | TXCIE | CHEN |   |   |   |   |   |   |   |   |   |   |   |   |   |   |   |   |   |   |   |   |
|        | DMA_CHCFG5  | Reserved   |    |    |    |    |    |    |    |    |    |    |    |    |    |    | MEM2MEM    | PRIOLVL[1:0] | Mysize[1:0] | PSIZE[1:0] | MINC | PINC | CIRC | DIR | ERRIE | HTXIE       | TXCIE | CHEN |   |   |   |   |   |   |   |   |   |   |   |   |   |   |   |   |   |   |   |   |
| 05Ch   | Reset Value | Reserved   |    |    |    |    |    |    |    |    |    |    |    |    |    |    | NDTX[15:0] |              |             |            |      |      |      |     |       |             |       |      |   |   |   |   |   |   |   |   |   |   |   |   |   |   |   |   |   |   |   |   |
|        | DMA_TXNUM5  | Reserved   |    |    |    |    |    |    |    |    |    |    |    |    |    |    | NDTX[15:0] |              |             |            |      |      |      |     |       |             |       |      |   |   |   |   |   |   |   |   |   |   |   |   |   |   |   |   |   |   |   |   |
| 060h   | Reset Value | 0          |    |    |    |    |    |    |    |    |    |    |    |    |    |    |            |              |             |            |      |      |      |     |       |             |       |      |   |   |   |   |   |   |   |   |   |   |   |   |   |   |   |   |   |   |   |   |
|        | DMA_PADDR5  | ADDR[31:0] |    |    |    |    |    |    |    |    |    |    |    |    |    |    |            |              |             |            |      |      |      |     |       |             |       |      |   |   |   |   |   |   |   |   |   |   |   |   |   |   |   |   |   |   |   |   |
| 064h   | Reset Value | 0          |    |    |    |    |    |    |    |    |    |    |    |    |    |    |            |              |             |            |      |      |      |     |       |             |       |      |   |   |   |   |   |   |   |   |   |   |   |   |   |   |   |   |   |   |   |   |
|        | DMA_MADDR5  | ADDR[31:0] |    |    |    |    |    |    |    |    |    |    |    |    |    |    |            |              |             |            |      |      |      |     |       |             |       |      |   |   |   |   |   |   |   |   |   |   |   |   |   |   |   |   |   |   |   |   |
| 068h   | Reset Value | Reserved   |    |    |    |    |    |    |    |    |    |    |    |    |    |    |            |              |             |            |      |      |      |     |       | CH_SEL[5:0] |       |      | 0 | 0 | 0 | 0 | 0 | 0 |   |   |   |   |   |   |   |   |   |   |   |   |   |   |
|        | DMA_CHSEL5  | Reserved   |    |    |    |    |    |    |    |    |    |    |    |    |    |    |            |              |             |            |      |      |      |     |       | CH_SEL[5:0] |       |      | 0 | 0 | 0 | 0 | 0 | 0 |   |   |   |   |   |   |   |   |   |   |   |   |   |   |
| 06Ch   | Reset Value | Reserved   |    |    |    |    |    |    |    |    |    |    |    |    |    |    | MEM2MEM    | PRIOLVL[1:0] | Mysize[1:0] | PSIZE[1:0] | MINC | PINC | CIRC | DIR | ERRIE | HTXIE       | TXCIE | CHEN |   |   |   |   |   |   |   |   |   |   |   |   |   |   |   |   |   |   |   |   |
|        | DMA_CHCFG6  | Reserved   |    |    |    |    |    |    |    |    |    |    |    |    |    |    | MEM2MEM    | PRIOLVL[1:0] | Mysize[1:0] | PSIZE[1:0] | MINC | PINC | CIRC | DIR | ERRIE | HTXIE       | TXCIE | CHEN |   |   |   |   |   |   |   |   |   |   |   |   |   |   |   |   |   |   |   |   |
| 070h   | Reset Value | Reserved   |    |    |    |    |    |    |    |    |    |    |    |    |    |    | NDTX[15:0] |              |             |            |      |      |      |     |       |             |       |      |   |   |   |   |   |   |   |   |   |   |   |   |   |   |   |   |   |   |   |   |
|        | DMA_TXNUM6  | Reserved   |    |    |    |    |    |    |    |    |    |    |    |    |    |    | NDTX[15:0] |              |             |            |      |      |      |     |       |             |       |      |   |   |   |   |   |   |   |   |   |   |   |   |   |   |   |   |   |   |   |   |
| 074h   | Reset Value | 0          |    |    |    |    |    |    |    |    |    |    |    |    |    |    |            |              |             |            |      |      |      |     |       |             |       |      |   |   |   |   |   |   |   |   |   |   |   |   |   |   |   |   |   |   |   |   |
|        | DMA_PADDR6  | ADDR[31:0] |    |    |    |    |    |    |    |    |    |    |    |    |    |    |            |              |             |            |      |      |      |     |       |             |       |      |   |   |   |   |   |   |   |   |   |   |   |   |   |   |   |   |   |   |   |   |
| 078h   | Reset Value | 0          |    |    |    |    |    |    |    |    |    |    |    |    |    |    |            |              |             |            |      |      |      |     |       |             |       |      |   |   |   |   |   |   |   |   |   |   |   |   |   |   |   |   |   |   |   |   |
|        | DMA_MADDR6  | ADDR[31:0] |    |    |    |    |    |    |    |    |    |    |    |    |    |    |            |              |             |            |      |      |      |     |       |             |       |      |   |   |   |   |   |   |   |   |   |   |   |   |   |   |   |   |   |   |   |   |
| 07Ch   | Reset Value | Reserved   |    |    |    |    |    |    |    |    |    |    |    |    |    |    |            |              |             |            |      |      |      |     |       | CH_SEL[5:0] |       |      | 0 | 0 | 0 | 0 | 0 | 0 |   |   |   |   |   |   |   |   |   |   |   |   |   |   |
|        | DMA_CHSEL6  | Reserved   |    |    |    |    |    |    |    |    |    |    |    |    |    |    |            |              |             |            |      |      |      |     |       | CH_SEL[5:0] |       |      | 0 | 0 | 0 | 0 | 0 | 0 |   |   |   |   |   |   |   |   |   |   |   |   |   |   |
| 080h   | Reset Value | Reserved   |    |    |    |    |    |    |    |    |    |    |    |    |    |    | MEM2MEM    | PRIOLVL[1:0] | Mysize[1:0] | PSIZE[1:0] | MINC | PINC | CIRC | DIR | ERRIE | HTXIE       | TXCIE | CHEN |   |   |   |   |   |   |   |   |   |   |   |   |   |   |   |   |   |   |   |   |
|        | DMA_CHCFG7  | Reserved   |    |    |    |    |    |    |    |    |    |    |    |    |    |    | MEM2MEM    | PRIOLVL[1:0] | Mysize[1:0] | PSIZE[1:0] | MINC | PINC | CIRC | DIR | ERRIE | HTXIE       | TXCIE | CHEN |   |   |   |   |   |   |   |   |   |   |   |   |   |   |   |   |   |   |   |   |
| 084h   | Reset Value | Reserved   |    |    |    |    |    |    |    |    |    |    |    |    |    |    | NDTX[15:0] |              |             |            |      |      |      |     |       |             |       |      |   |   |   |   |   |   |   |   |   |   |   |   |   |   |   |   |   |   |   |   |
|        | DMA_TXNUM7  | Reserved   |    |    |    |    |    |    |    |    |    |    |    |    |    |    | NDTX[15:0] |              |             |            |      |      |      |     |       |             |       |      |   |   |   |   |   |   |   |   |   |   |   |   |   |   |   |   |   |   |   |   |
| 088h   | Reset Value | 0          |    |    |    |    |    |    |    |    |    |    |    |    |    |    |            |              |             |            |      |      |      |     |       |             |       |      |   |   |   |   |   |   |   |   |   |   |   |   |   |   |   |   |   |   |   |   |
|        | DMA_PADDR7  | ADDR[31:0] |    |    |    |    |    |    |    |    |    |    |    |    |    |    |            |              |             |            |      |      |      |     |       |             |       |      |   |   |   |   |   |   |   |   |   |   |   |   |   |   |   |   |   |   |   |   |
| 08Ch   | Reset Value | 0          |    |    |    |    |    |    |    |    |    |    |    |    |    |    |            |              |             |            |      |      |      |     |       |             |       |      |   |   |   |   |   |   |   |   |   |   |   |   |   |   |   |   |   |   |   |   |
|        | DMA_MADDR7  | ADDR[31:0] |    |    |    |    |    |    |    |    |    |    |    |    |    |    |            |              |             |            |      |      |      |     |       |             |       |      |   |   |   |   |   |   |   |   |   |   |   |   |   |   |   |   |   |   |   |   |
| 090h   | Reset Value | Reserved   |    |    |    |    |    |    |    |    |    |    |    |    |    |    |            |              |             |            |      |      |      |     |       | CH_SEL[5:0] |       |      | 0 | 0 | 0 | 0 | 0 | 0 |   |   |   |   |   |   |   |   |   |   |   |   |   |   |
|        | DMA_CHSEL7  | Reserved   |    |    |    |    |    |    |    |    |    |    |    |    |    |    |            |              |             |            |      |      |      |     |       | CH_SEL[5:0] |       |      | 0 | 0 | 0 | 0 | 0 | 0 |   |   |   |   |   |   |   |   |   |   |   |   |   |   |
| 094h   | Reset Value | Reserved   |    |    |    |    |    |    |    |    |    |    |    |    |    |    | MEM2MEM    | PRIOLVL[1:0] | Mysize[1:0] | PSIZE[1:0] | MINC | PINC | CIRC | DIR | ERRIE | HTXIE       | TXCIE | CHEN |   |   |   |   |   |   |   |   |   |   |   |   |   |   |   |   |   |   |   |   |
|        | DMA_CHCFG8  | Reserved   |    |    |    |    |    |    |    |    |    |    |    |    |    |    | MEM2MEM    | PRIOLVL[1:0] | Mysize[1:0] | PSIZE[1:0] | MINC | PINC | CIRC | DIR | ERRIE | HTXIE       | TXCIE | CHEN |   |   |   |   |   |   |   |   |   |   |   |   |   |   |   |   |   |   |   |   |
| 098h   | Reset Value | Reserved   |    |    |    |    |    |    |    |    |    |    |    |    |    |    | NDTX[15:0] |              |             |            |      |      |      |     |       |             |       |      |   |   |   |   |   |   |   |   |   |   |   |   |   |   |   |   |   |   |   |   |
|        | DMA_TXNUM8  | Reserved   |    |    |    |    |    |    |    |    |    |    |    |    |    |    | NDTX[15:0] |              |             |            |      |      |      |     |       |             |       |      |   |   |   |   |   |   |   |   |   |   |   |   |   |   |   |   |   |   |   |   |
| 09Ch   | Reset Value | 0          |    |    |    |    |    |    |    |    |    |    |    |    |    |    |            |              |             |            |      |      |      |     |       |             |       |      |   |   |   |   |   |   |   |   |   |   |   |   |   |   |   |   |   |   |   |   |
|        | DMA_PADDR8  | ADDR[31:0] |    |    |    |    |    |    |    |    |    |    |    |    |    |    |            |              |             |            |      |      |      |     |       |             |       |      |   |   |   |   |   |   |   |   |   |   |   |   |   |   |   |   |   |   |   |   |
| 0A0h   | Reset Value | 0          |    |    |    |    |    |    |    |    |    |    |    |    |    |    |            |              |             |            |      |      |      |     |       |             |       |      |   |   |   |   |   |   |   |   |   |   |   |   |   |   |   |   |   |   |   |   |
|        | DMA_MADDR8  | ADDR[31:0] |    |    |    |    |    |    |    |    |    |    |    |    |    |    |            |              |             |            |      |      |      |     |       |             |       |      |   |   |   |   |   |   |   |   |   |   |   |   |   |   |   |   |   |   |   |   |
| 0A4h   | Reset Value | Reserved   |    |    |    |    |    |    |    |    |    |    |    |    |    |    |            |              |             |            |      |      |      |     |       | CH_SEL[5:0] |       |      | 0 | 0 | 0 | 0 | 0 | 0 |   |   |   |   |   |   |   |   |   |   |   |   |   |   |
|        | DMA_CHSEL8  | Reserved   |    |    |    |    |    |    |    |    |    |    |    |    |    |    |            |              |             |            |      |      |      |     |       | CH_SEL[5:0] |       |      | 0 | 0 | 0 | 0 | 0 | 0 |   |   |   |   |   |   |   |   |   |   |   |   |   |   |

|        |             |          |    |    |    |    |    |    |    |    |    |    |    |    |    |    |    |    |    |    |    |    |    |   |   |   |   |        |   |   |   |   |   |
|--------|-------------|----------|----|----|----|----|----|----|----|----|----|----|----|----|----|----|----|----|----|----|----|----|----|---|---|---|---|--------|---|---|---|---|---|
| Offset | Register    | 31       | 30 | 29 | 28 | 27 | 26 | 25 | 24 | 23 | 22 | 21 | 20 | 19 | 18 | 17 | 16 | 15 | 14 | 13 | 12 | 11 | 10 | 9 | 8 | 7 | 6 | 5      | 4 | 3 | 2 | 1 | 0 |
| 0A8h   | DMA_CHMAPEN | Reserved |    |    |    |    |    |    |    |    |    |    |    |    |    |    |    |    |    |    |    |    |    |   |   |   |   | MAP_EN |   |   |   |   |   |
|        | Reset Value |          |    |    |    |    |    |    |    |    |    |    |    |    |    |    |    |    |    |    |    |    |    |   |   |   |   | 0      |   |   |   |   |   |

## 8.5.2 DMA interrupt status register (DMA\_INTSTS)

Address offset: 0x00

Reset value: 0x0000 0000

|       |       |       |       |       |       |       |       |       |       |       |       |       |       |       |       |
|-------|-------|-------|-------|-------|-------|-------|-------|-------|-------|-------|-------|-------|-------|-------|-------|
| 31    | 30    | 29    | 28    | 27    | 26    | 25    | 24    | 23    | 22    | 21    | 20    | 19    | 18    | 17    | 16    |
| ERRF8 | HTXF8 | TXCF8 | GLBF8 | ERRF7 | HTXF7 | TXCF7 | GLBF7 | ERRF6 | HTXF6 | TXCF6 | GLBF6 | ERRF5 | HTXF5 | TXCF5 | GLBF5 |
| r     | r     | r     | r     | r     | r     | r     | r     | r     | r     | r     | r     | r     | r     | r     | r     |
| 15    | 14    | 13    | 12    | 11    | 10    | 9     | 8     | 7     | 6     | 5     | 4     | 3     | 2     | 1     | 0     |
| ERRF4 | HTXF4 | TXCF4 | GLBF4 | ERRF3 | HTXF3 | TXCF3 | GLBF3 | ERRF2 | HTXF2 | TXCF2 | GLBF2 | ERRF1 | HTXF1 | TXCF1 | GLBF1 |
| r     | r     | r     | r     | r     | r     | r     | r     | r     | r     | r     | r     | r     | r     | r     | r     |

| Bit field             | Name  | Description   |
|-----------------------|-------|---|
| 31/27/23/19/15/11/7/3 | ERRFx | Transfer error flag for channel x (x=1...8).<br>Hardware sets this bit when transfer error happen. This bit is cleared by software by writing '1' to DMA_INTCLR.CERRFx bit.<br>0: Transfer error no happened on channel x.<br>1: Transfer error happened on channel x.  |
| 30/26/22/18/14/10/6/2 | HTXFx | Half transfer flag for channel x (x=1...8).<br>Hardware sets this bit when half transfer is done. This bit is cleared by software by writing '1' to DMA_INTCLR.CHTXFx bit.<br>0: Half transfer not yet done on channel x.<br>1: Half transfer was done on channel x.  |
| 29/25/21/17/13/9/5/1  | TXCFx | Transfer complete flag for channel x (x=1...8).<br>Hardware sets this bit when transfer is done. This bit is cleared by software by writing '1' to DMA_INTCLR.CTXCFx bit.<br>0: Transfer not yet done on channel x.<br>1: Transfer was done on channel x.   |
| 28/24/20/16/12/8/4/0  | GLBFx | Global flag for channel x (x=1...8).<br>Hardware sets this bit when any interrupt events happen in this channel. This bit is cleared by software by writing '1' to DMA_INTCLR.CGLBFx bit.<br>0: No transfer error, half transfer or transfer done event happen on channel x.<br>1: One of transfer error, half transfer or transfer done event happen on channel x. |

## 8.5.3 DMA interrupt flag clear register (DMA\_INTCLR)

Address offset: 0x04

Reset value: 0x0000 0000

|        |        |        |        |        |        |        |        |        |        |        |        |        |        |        |        |
|--------|--------|--------|--------|--------|--------|--------|--------|--------|--------|--------|--------|--------|--------|--------|--------|
| 31     | 30     | 29     | 28     | 27     | 26     | 25     | 24     | 23     | 22     | 21     | 20     | 19     | 18     | 17     | 16     |
| CERRF8 | CHTXF8 | CTXCF8 | CGLBF8 | CERRF7 | CHTXF7 | CTXCF7 | CGLBF7 | CERRF6 | CHTXF6 | CTXCF6 | CGLBF6 | CERRF5 | CHTXF5 | CTXCF5 | CGLBF5 |
| rw     | rw     | rw     | rw     | rw     | rw     | rw     | rw     | rw     | rw     | rw     | rw     | rw     | rw     | rw     | rw     |
| 15     | 14     | 13     | 12     | 11     | 10     | 9      | 8      | 7      | 6      | 5      | 4      | 3      | 2      | 1      | 0      |
| CERRF4 | CHTXF4 | CTXCF4 | CGLBF4 | CERRF3 | CHTXF3 | CTXCF3 | CGLBF3 | CERRF2 | CHTXF2 | CTXCF2 | CGLBF2 | CERRF1 | CHTXF1 | CTXCF1 | CGLBF1 |
| rw     | rw     | rw     | rw     | rw     | rw     | rw     | rw     | rw     | rw     | rw     | rw     | rw     | rw     | rw     | rw     |

| Bit field             | Name               | Description   |
|-----------------------|--------------------|---|
| 31/27/23/19/15/11/7/3 | CERRF <sub>x</sub> | Clear transfer error flag for channel x (x=1...8).<br>Software can set this bit to clear ERRF of corresponding channel.<br>0: No action.<br>1: Reset DMA_INTSTS.ERRF bit of corresponding channel.    |
| 30/26/22/18/14/10/6/2 | CHTXF <sub>x</sub> | Clear half transfer flag for channel x (x=1...8).<br>Software can set this bit to clear HTXF of corresponding channel.<br>0: No action.<br>1: Reset DMA_INTSTS.HTXF bit of corresponding channel.     |
| 29/25/21/17/13/9/5/1  | CTXCF <sub>x</sub> | Clear transfer complete flag for channel x (x=1...8).<br>Software can set this bit to clear TXCF of corresponding channel.<br>0: No action.<br>1: Reset DMA_INTSTS.TXCF bit of corresponding channel. |
| 28/24/20/16/12/8/4/0  | CGLBF <sub>x</sub> | Clear global event flag for channel x (x=1...8).<br>Software can set this bit to clear GLBF of corresponding channel.<br>0: No action.<br>1: Reset DMA_INTSTS.GLBF bit of corresponding channel.      |

## 8.5.4 DMA channel x configuration register (DMA\_CHCFG<sub>x</sub>)

The x is channel number, x = 1...8

Address offset: 0x08+20 \* (x-1)

Reset value: 0x0000 0000

|          |             |              |            |            |      |      |      |     |       |       |       |      |    |    |    |
|----------|-------------|--------------|------------|------------|------|------|------|-----|-------|-------|-------|------|----|----|----|
| 31       | Reserved    |              |            |            |      |      |      |     |       |       |       |      | 16 |    |    |
| 15       | 14          | 13           | 12         | 11         | 10   | 9    | 8    | 7   | 6     | 5     | 4     | 3    | 2  | 1  | 0  |
| Reserved | MEM2<br>MEM | PRIOLVL[1:0] | MSIZE[1:0] | PSIZE[1:0] | MINC | PINC | CIRC | DIR | ERRIE | HTXIE | TXCIE | CHEN |    |    |    |
|          | rw          | rw           | rw         | rw         | rw   | rw   | rw   | rw  | rw    | rw    | rw    | rw   | rw | rw | rw |

| Bit field | Name     | Description  |
|-----------|----------|--|
| 31:15     | Reserved | Reserved, the reset value must be maintained.  |
| 14        | MEM2MEM  | Memory to memory mode.<br>Software can configure this channel to memory to memory transfer when it is not yet enabled.<br>0: Channel transfer between memory and peripheral.<br>1: Channel set to memory to memory transfer. |

| Bit field | Name         | Description  |
|-----------|--------------|--|
| 13:12     | PRIOLVL[1:0] | Channel priority.<br>Software can program channel priority when channel is not enable.<br>00: Low<br>01: Medium<br>10: High<br>11: Very high   |
| 11:10     | MSIZE[1:0]   | Memory data size.<br>Software can configure data size read/write from/to memory address.<br>00: 8-bits<br>01: 16-bits<br>10: 32-bits<br>11: Reserved   |
| 9:8       | PSIZE[1:0]   | Peripheral data size.<br>Software can configure data size read/write from/to peripheral address.<br>00: 8-bits<br>01: 16-bits<br>10: 32-bits<br>11: Reserved   |
| 7         | MINC         | Memory increment mode.<br>Software can enable/disable memory address increment mode.<br>0: Memory address won't increase with each transfer.<br>1: Memory address increase with each transfer.                 |
| 6         | PINC         | Peripheral increment mode.<br>Software can enable/disable peripheral address increment mode.<br>0: Peripheral address won't increase with each transfer.<br>1: Peripheral address increase with each transfer. |
| 5         | CIRC         | Circular mode.<br>Software can set/clear this bit.<br>0: Channel will stop after one round of transfer.<br>1: Channel configure as circular mode.  |
| 4         | DIR          | Data transfer direction<br>Software can set/clear this bit.<br>0: Data transfer from Peripheral to Memory<br>1: Data transfer from Memory to Peripheral.   |
| 3         | ERRIE        | Transfer error interrupt enable.<br>Software can enable/disable transfer error interrupt.<br>0: Disable transfer error interrupt of channel x.<br>1: Enable transfer error interrupt of channel x.             |
| 2         | HTXIE        | Half transfer interrupt enable.<br>Software can enable/disable half transfer interrupt.<br>0: Disable half transfer interrupt of channel x.<br>1: Enable half transfer interrupt of channel x.                 |
| 1         | TXCIE        | Transfer complete interrupt enable.  |

| Bit field | Name | Description   |
|-----------|------|---|
|           |      | Software can enable/disable transfer complete interrupt.<br>0: Disable transfer complete interrupt of channel x.<br>1: Enable transfer complete interrupt of channel x. |
| 0         | CHEN | Channel enable.<br>Software can set/reset this bit.<br>0: Disable channel.<br>1: Enable channel.  |

### 8.5.5 DMA channel x transfer number register (DMA\_TXNUM<sub>x</sub>)

The x is channel number, x = 1...8

Address offset: 0x0c+20 \* (x-1)

Reset value: 0x0000 0000

This register can only be written if the channel is disabled (DMA\_CHCFG<sub>x</sub>.CHEN = 0).

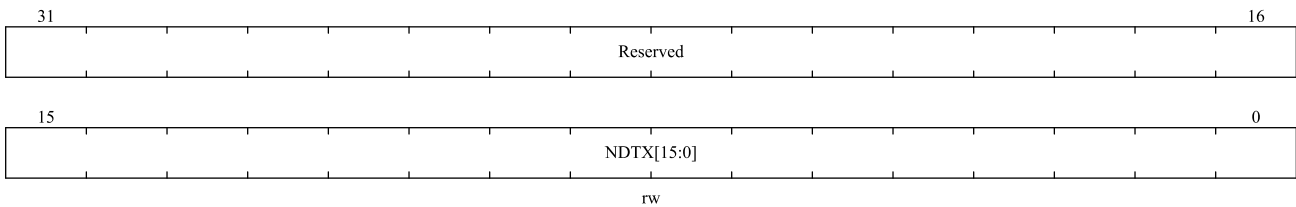

| Bit field | Name     | Description  |
|-----------|----------|--|
| 31:16     | Reserved | Reserved, the reset value must be maintained.  |
| 15:0      | NDTX     | Number of data to transfer.<br>Number of data to be transferred (0~65535). Software can read/write the number of transfers when channel is disable and it will be read only after channel enable. Every successful transfer of corresponding DMA channel will decrease this register by 1. If circular mode is enable, it will automatically reload pre-set value when it reach zero. Otherwise it will keep at zero and reset channel enable. |

### 8.5.6 DMA channel x peripheral address register (DMA\_PADDR<sub>x</sub>)

The x is channel number, x = 1...8

Address offset: 0x10+20 \* (x-1)

Reset value: 0x0000 0000

This register can only be written if the channel is disabled (DMA\_CHCFG<sub>x</sub>.CHEN = 0).

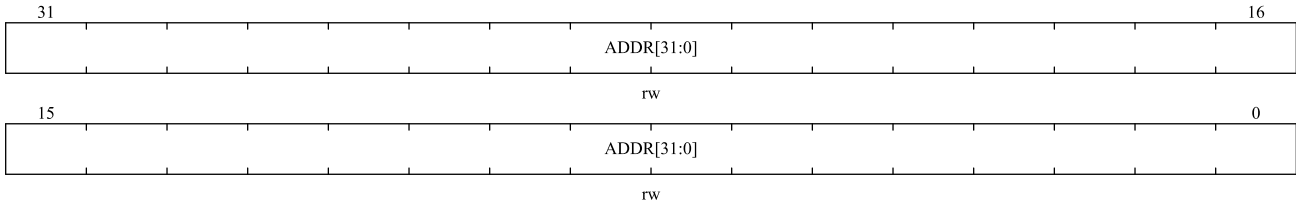

| Bit field | Name | Description  |
|-----------|------|--|
| 31:0      | ADDR | Peripheral address.<br>Peripheral starting address for DMA to read/write from/to.<br>Increment of address will be decided by DMA_CHCFGx.PSIZE. With DMA_CHCFGx.PSIZE equal to 01, DMA ignores bit 0 of PADDR and if DMA_CHCFGx.PSIZE equal to 10 DMA will ignore bit [1:0] of PADDR. |

### 8.5.7 DMA channel x memory address register (DMA\_MADDRx)

The x is channel number, x = 1...8

Address offset:  $0x14+20 * (x-1)$

Reset value: 0x0000 0000

This register can only be written if the channel is disabled (DMA\_CHCFGx.CHEN = 0).

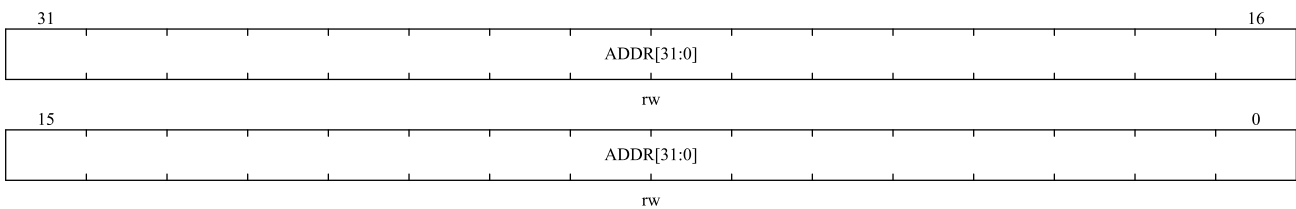

| Bit field | Name | Description   |
|-----------|------|---|
| 31:0      | ADDR | ADDR Memory address.<br>Memory starting address for DMA to read/write from/to.<br>Increment of address will be decided by DMA_CHCFGx.MSIZE. With DMA_CHCFGx.MSIZE equal to 01, DMA ignores bit 0 of MADDR and if DMA_CHCFGx.MSIZE equal to 10 DMA will ignore bit [1:0] of MADDR. |

### 8.5.8 DMA1 channel x channel request select register (DMA1\_CHSELx)

The x is channel number, x = 1...8

Address offset:  $0x18+20 * (x-1)$

Reset value: 0x0000 0000

Writing to this register is only valid when the channel MAP is enabled (DMA\_CHMAPEN.MAP\_EN=1). This register is used to manage the DMA1 channel mapped by the DMA1 peripheral request.

*Note: After the channel MAP is enabled, DMA channel selection register will change to the default value. It is necessary to configure the corresponding mapping for each channel that has been used. If it is not reconfigured, all*

channels of DMA1 will only respond to the DMA request of ADC1.

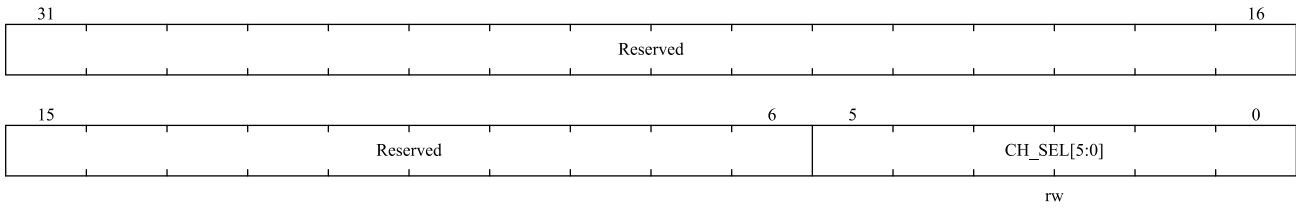

| Bit field | Name        | Description  |
|-----------|-------------|--|
| 31:6      | Reserved    | Reserved, the reset value must be maintained.  |
| 5:0       | CH_SEL[5:0] | DMA1 channel request source selection<br>40: UART5_RX<br>39: ADC2<br>38: I2C1_RX<br>37: TIM4_UP<br>36: TIM2_CH4<br>35: TIM2_CH2<br>34: USART2_TX<br>33: I2C1_TX<br>32: TIM3_TRIG<br>31: TIM3_CH1<br>30: TIM1_CH3<br>29: USART2_RX<br>28: I2C2_RX<br>27: TIM4_CH3<br>26: TIM2_CH1<br>25: SPI2/I2S2_TX<br>24: TIM1_UP<br>23: USART1_RX<br>22: I2C2_TX<br>21: SPI2/I2S2_RX<br>20: TIM4_CH2<br>19: TIM1_COM<br>18: TIM1_TRIG<br>17: TIM1_CH4<br>16: USART1_TX<br>15: SPI1_TX<br>14: TIM3_UP<br>13: TIM3_CH4<br>12: TIM1_CH2<br>11: USART3_RX<br>10: SPI1_RX<br>9: TIM3_CH3<br>8: TIM2_UP |

| Bit field | Name | Description   |
|-----------|------|---|
|           |      | 7: TIM1_CH1<br>6: I2C3_RX<br>5: USART3_TX<br>4: TIM4_CH1<br>3: TIM2_CH3<br>2: I2C3_TX<br>1: UART5_TX<br>0: ADC1 |

### 8.5.9 DMA2 channel x channel request select register (DMA2\_CHSELx)

The x is channel number,  $x = 1 \dots 8$

Address offset:  $0x18 + 20 * (x - 1)$

Reset value: 0x0000 0000

Writing to this register is only valid when the channel MAP is enabled (DMA\_CHMAPEN.MAP\_EN=1). This register is used to manage the DMA2 channel mapped by the DMA2 peripheral request.

*Note: After the channel MAP is enabled, DMA channel selection register will change to the default value. It is necessary to configure the corresponding mapping for each channel that has been used. If it is not reconfigured, all channels of DMA2 will only respond to the DMA request of TIM5\_CH4.*

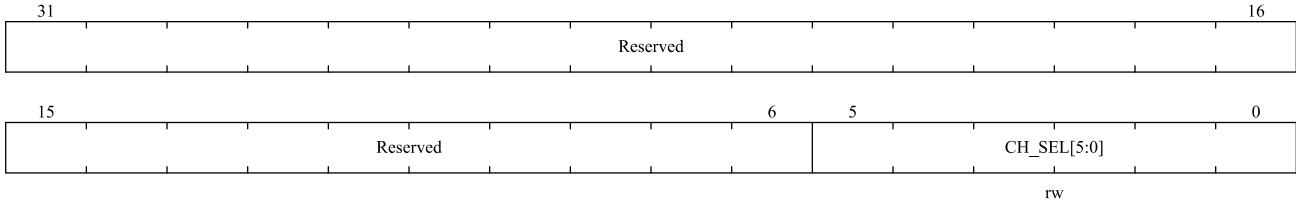

| Bit field | Name        | Description  |
|-----------|-------------|--|
| 31:6      | Reserved    | Reserved, the reset value must be maintained.  |
| 5:0       | CH_SEL[5:0] | DMA2 channel request source selection<br>32: DVP<br>31: ADC4<br>30: UART7_TX<br>29: I2C4_RX<br>28: QSPI_TX<br>27: UART7_RX<br>26: I2C4_TX<br>25: QSPI_RX<br>24: UART4_TX<br>23: TIM5_CH1<br>22: TIM8_CH2<br>21: ADC3<br>20: DAC2 |

| Bit field | Name | Description  |
|-----------|------|--|
|           |      | 19: TIM7_UP<br>18: SDIO<br>17: TIM5_CH2<br>16: DAC1<br>15: TIM6_UP<br>14: UART4_RX<br>13: TIM8_CH1<br>12: UART6_TX<br>11: SPI3/I2S3_TX<br>10: TIM5_UP<br>9: TIM5_CH3<br>8: TIM8_COM<br>7: TIM8_TRIG<br>6: TIM8_CH4<br>5: UART6_RX<br>4: SPI3/I2S3_RX<br>3: TIM8_UP<br>2: TIM8_CH3<br>1: TIM5_TRIG<br>0: TIM5_CH4 |

### 8.5.10 DMA channel MAP enable register (DMA\_CHMAPEN)

Address offset: 0xA8

Reset value: 0x0000 0000

*Note: After the MAP is enabled, DMA will respond to the DMA request according to the configuration of the selection register. It is necessary to configure the channel request selection of the peripheral. If it is not configured, DMA will only respond to the default value of the channel selection register (DMA1 is ADC1, DMA2 is TIM5\_CH4).*

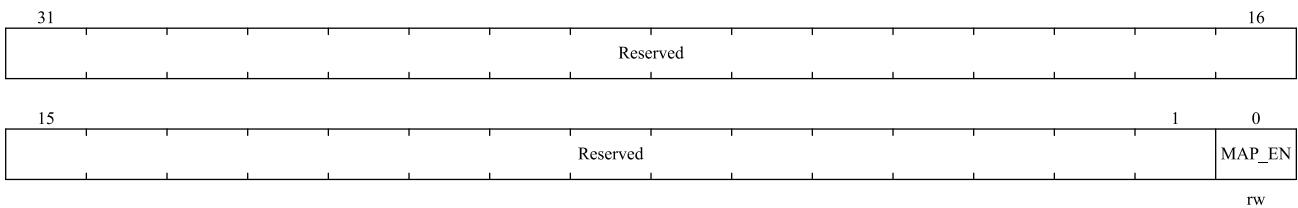

| Bit field | Name     | Description  |
|-----------|----------|--|
| 31:1      | Reserved | Reserved, the reset value must be maintained.                          |
| 0         | MAP_EN   | Channel MAP enable.<br>0: Disable channel MAP<br>1: Enable channel MAP |

## 9 Analog to digital conversion (ADC)

### 9.1 Introduction

The 12-bit ADC is a high-speed analog-to-digital converter using successive approximation. It has multiple channels. The A/D conversion of each channel has four execution modes: single, continuous, scan or discontinuous. ADC measurements are stored (left-aligned/ right-aligned) in 16-bit data registers. The application can detect that the input voltage is within user-defined high/low thresholds by analog watchdog and the maximum frequency of the input clock to the ADC is 80MHz.

### 9.2 Main features

- Supports 4 ADC, supports single-ended and differential inputs, and can measure up to 40 external and 7 internal sources.
- ADC1 supports 11 external channels, ADC2 supports 13 external channels, ADC3 supports 15 external channels, and ADC4 supports 13 external channels.
- Support 12-bit, 10-bit, 8-bit, 6-bit resolution configurable.
  - ◆ The highest sampling rate 4.7MSPS under 12bit resolution.
  - ◆ The highest sampling rate 6.1MSPS under 10bit resolution.
  - ◆ The highest sampling rate 7.3MSPS under 8bit resolution.
  - ◆ The highest sampling rate 8.9MSPS under 6bit resolution.
- ADC clock source is divided into working clock source, sampling clock source and timing clock source
  - ◆ Only AHB\_CLK can be configured as the working clock source, up to 144MHz.
  - ◆ PLL can be configured as a sampling clock source, up to 80MHz, support frequency division 1,2,4,6,8,10,12,16,32,64,128,256.
  - ◆ The AHB\_CLK can be configured as the sampling clock source, up to 80MHz, and supports frequency division 1,2,4,6,8,10,12,16,32.
  - ◆ The timing clock is used for internal timing functions and the frequency must be configured to 1MHz.
- Support trigger sampling, Including EXTI/TIMER.
- Programmable channel sampling interval.
- Support auto scan mode.
- Support 2 conversion modes.
  - ◆ Single conversion.
  - ◆ Continuous conversion.
- Support discontinuous mode.
- Support self-calibration.

- Support DMA.
- Interrupt generation.
  - ◆ At the end of conversion.
  - ◆ At the end of injection conversion.
  - ◆ Analog watchdog event.
- Data alignment with embedded data consistency.
- Both regular conversions and injection conversions have external triggering options.
- ADC power requirements: 1.8V to 3. 6V.
- ADC input voltage range:  $V_{REF-} \leq V_{IN} \leq V_{REF+}$ .
- Dual ADC mode, ADC1 and ADC2 combined, ADC3 and ADC4 combined.

### 9.3 Function Description

The block diagram and pin description of the ADC are as follows:

Figure 9-1 Block diagram of a single ADC

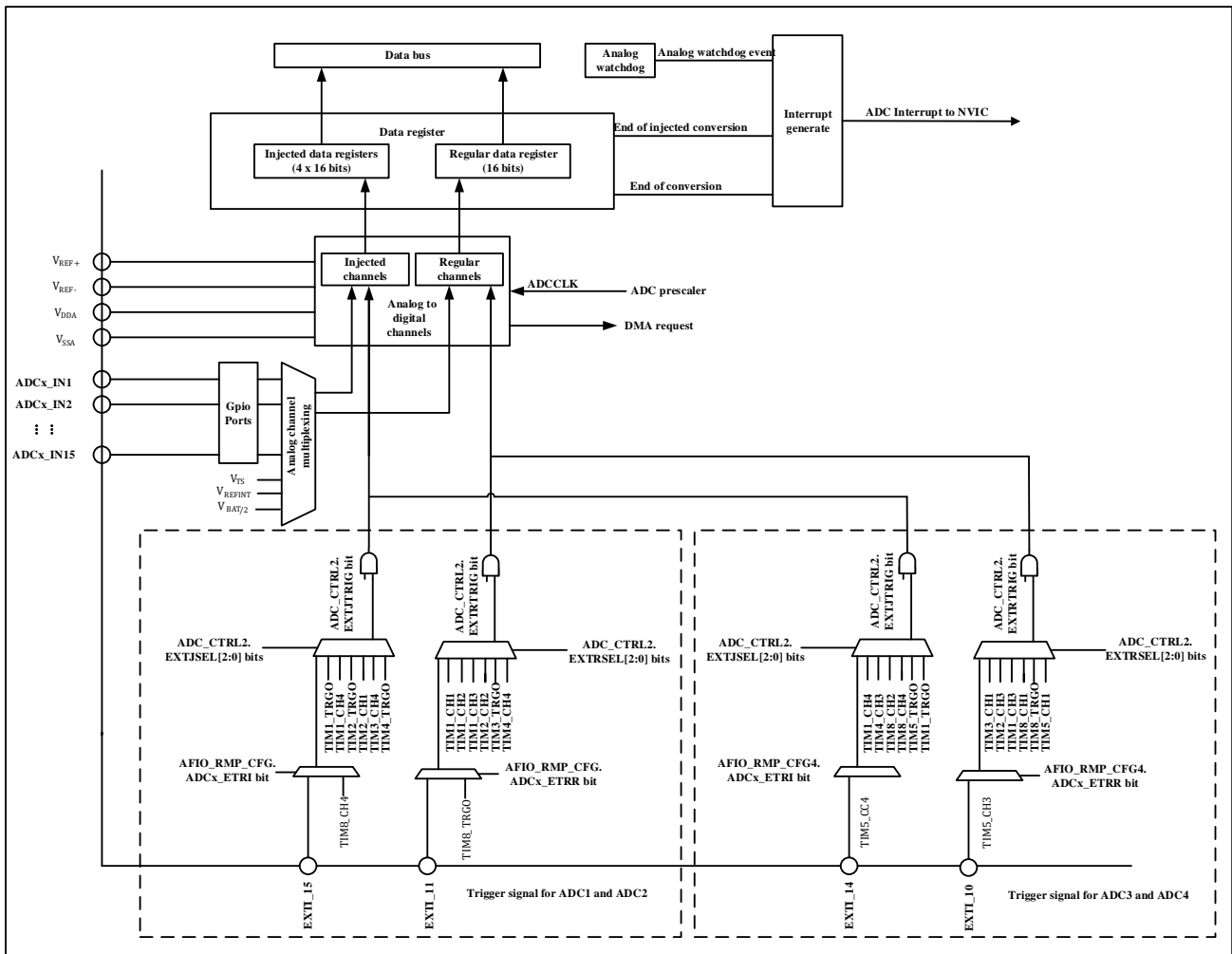

Table 9-1 ADC pins

| Name                 | Types                             | Description  |
|----------------------|-----------------------------------|--|
| V <sub>D</sub> DA    | Input, analog power supply        | Equivalent to V <sub>DD</sub> analog power supply and: $1.8V \leq V_{DDA} \leq V_{DD}(3.6V)$ |
| V <sub>S</sub> SA    | Input, analog power supply ground | Equivalent to V <sub>SS</sub> analog power supply ground                                     |
| V <sub>REF+</sub>    | Input, analog reference positive  | Positive reference voltage used by ADC, $1.8V \leq V_{REF+} \leq V_{DDA}$                    |
| V <sub>REF-</sub>    | Input, analog reference negative  | The low/negative reference voltage used by the ADC, $V_{REF-} = V_{SSA}$                     |
| ADC <sub>x</sub> _IN | Analog input signal               | Analog external input channels   |

Note:

1. V<sub>D</sub>DA and V<sub>S</sub>SA. They should be separately connected to V<sub>DD</sub> and V<sub>SS</sub>.
2. If there is a V<sub>REF-</sub> Pins (depending on the package), it must be connected to V<sub>S</sub>SA.
3. If there are no V<sub>REF+</sub> pins (depending on the package), try to ensure that the voltage values of V<sub>D</sub>DA and V<sub>DD</sub> are the same, otherwise the ADC accuracy will be affected.
4. External channel reference data sheet.

### 9.3.1 ADC clock

An ADC requires three clocks, HCLK, ADC\_CLK and ADC\_1MCLK.

- HCLK is used for the register access.
- ADC\_CLK is the working clock of ADC. ADC\_CLK has two sources (HCLK divider or PLL divider). HCLK divider and system are synchronous clock, while PLL divider and system are asynchronous clock. The advantage of using a synchronous clock is that there is no uncertainty when triggering the ADC to respond to the trigger. The advantage of using PLL's divider clock is that the ADC's working clock can be handled independently without affecting other modules attached to the HCLK
- ADC\_1MCLK for internal timing function, configured in RCC, frequency size must be configured to 1MHz

Note:

1. Configuration PLL as a clock source, up to 72 MHz, support frequency division 1,2,4,6,8,10,12,16,32, 64,128,256
2. The AHB\_CLK frequency division can be configured as a working clock up to 72MHz. The AHB\_CLK frequency division can be 1,2,4,6,8,10,12,16,32
3. When switching the ADC\_1M clock source, you need to ensure that the HSI clock is turned on

Figure 9-2 ADC clock

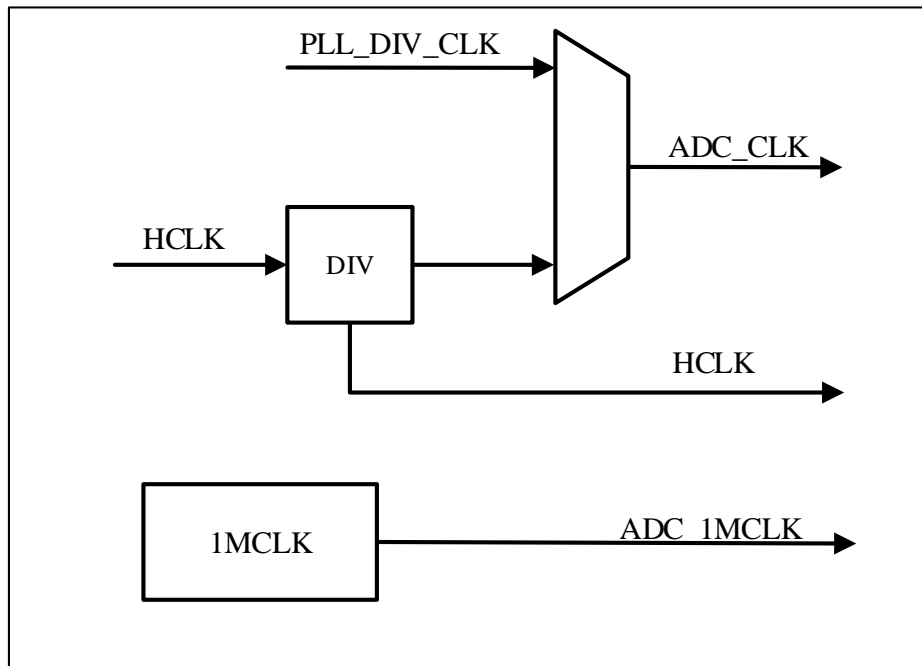

### 9.3.2 ADC switch control

You can proceed to the next step only after the power-up process is complete. You can check if the power-up is complete by polling the ADC\_CTRL3.RDY bit.

You can set the ADC\_CTRL2.ON bit to turn on the ADC. When the ADC\_CTRL2.ON bit is set for the first time, it wakes up the ADC from the power-off state. After a power-on delay of ADC ( $t_{STAB}$ ), and the conversion begins when the ADC\_CTRL2.ON bit is set again.

The conversion can be stopped by clearing the ADC\_CTRL2.ON bit and placing the ADC in power-off mode. In this mode, the ADC consumes almost no power (just a few  $\mu A$ ). Power-down can be checked by polling the ADC\_CTRL3.PDRDY bit.

When the ADC is disabled, the default mode is power-down. In this mode, as long as the power is on, there is no need to re-calibrate, and the calibration value is automatically maintained in the ADC. To further reduce power consumption, the ADC has a deep sleep mode. When ADC Disable is in deep sleep mode, the calibration value inside the ADC is lost and needs to be recalibrated. Deep sleep saves about  $0.2\mu A$  of power consumption.

*Note: That when in dual ADC mode, it is best to select the same sleep mode for both ADCs. Register ADC\_CTRL3.DPWMOD which controls ADC deep sleep mode.*

### 9.3.3 Channel selection

Each channel can be configured as a regular sequence and an injection sequence.

Injection sequence consists of multiple conversions, up to a maximum of 4. The ADC\_JSEQ register specifies the injection channel and the conversion order of the injection channel. The ADC\_JSEQ.JLEN[1:0] bits specified injection sequence length.

Regular sequence consists of multiple conversions, up to a maximum of 16. The ADC\_RSEQx registers specify the regular channels and the conversion order of the regular channels. The ADC\_RSEQ1.LEN[3:0] bits specified regular channel sequence length.

*Note: During conversion, changes to the ADC\_RSEQx or ADC\_JSEQ registers are prohibited; the ADC\_RSEQx or ADC\_JSEQ registers can only be changed when the ADC is idle.*

Figure 9-3 ADC1 and ADC2 channel pin connections

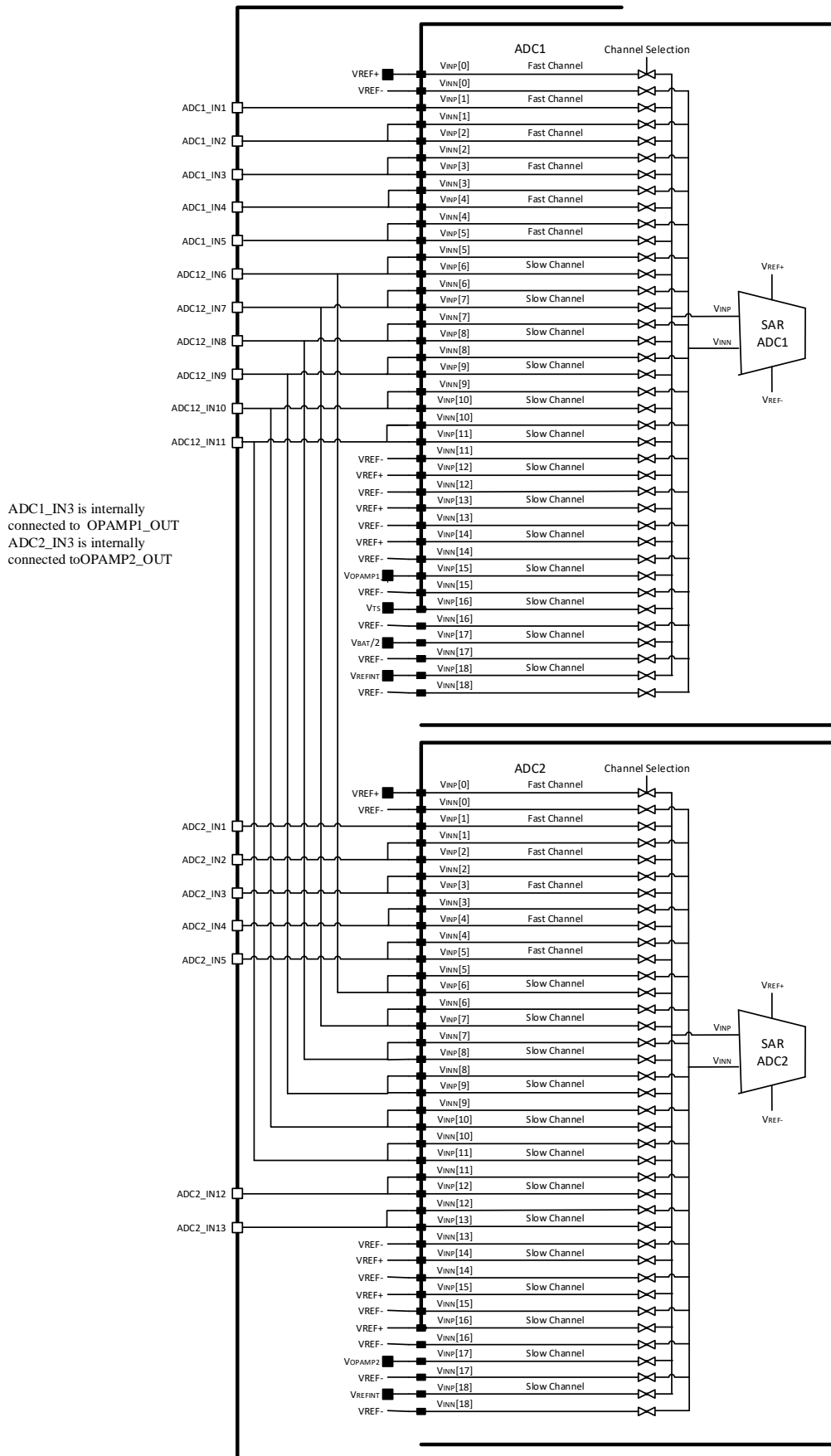
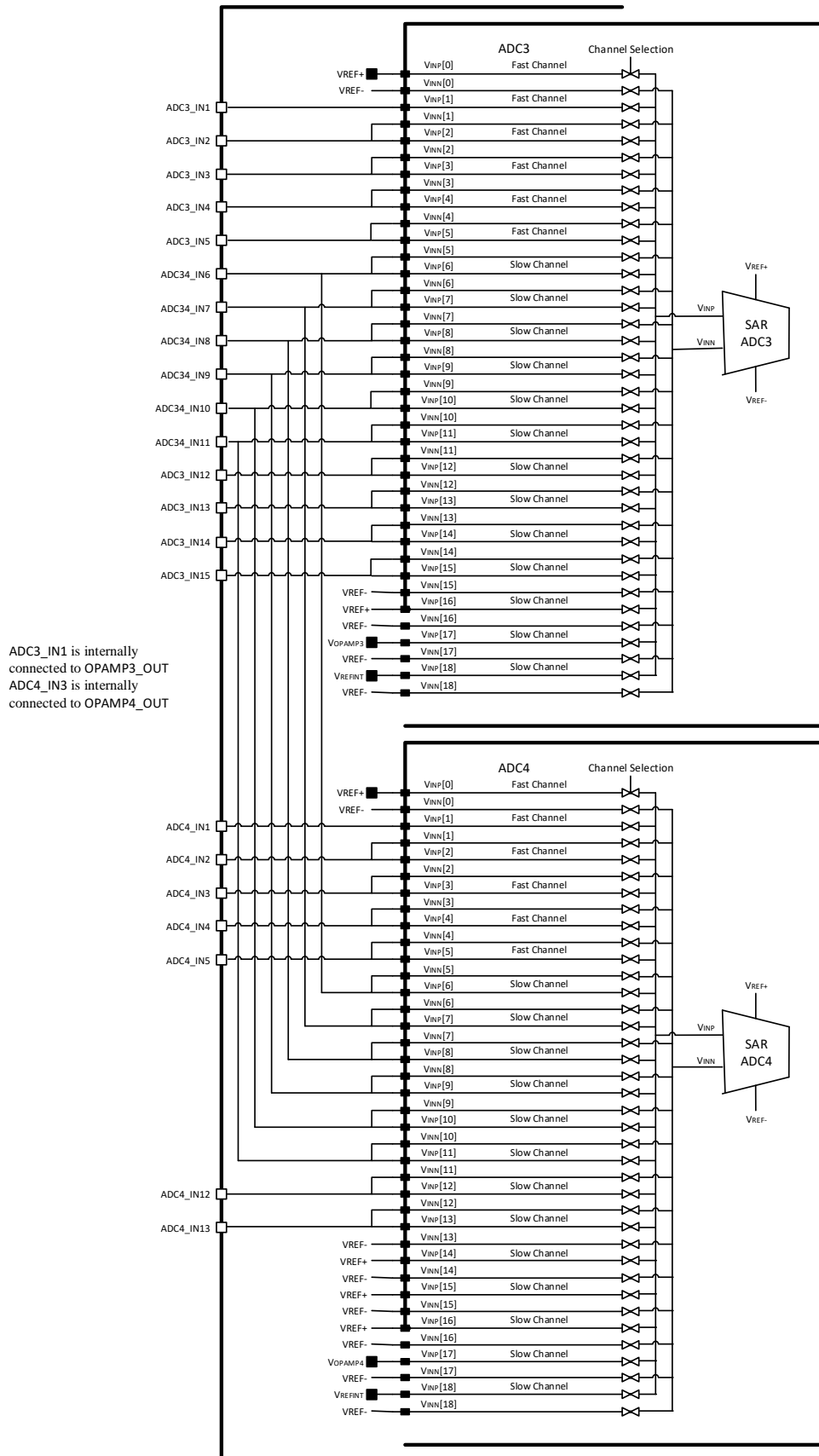

Figure 9-4 ADC3 and ADC4 channel pin connections



### 9.3.4 Internal channel

- The temperature sensor is connected to channel ADC1\_IN16.
- $V_{BAT/2}$  is connected to channel ADC1\_IN17.
- Internal reference voltage VREFINT is connected to ADC<sub>x</sub>\_IN18.
- V<sub>OP1OUT</sub> output is connected to channel ADC1\_IN3.
- V<sub>OP2OUT</sub> output is connected to channel ADC2\_IN3.
- V<sub>OP3OUT</sub> output is connected to channel ADC3\_IN1.
- V<sub>OP4OUT</sub> output is connected to channel ADC4\_IN3.

Internal channels can be converted by injection or regular channels.

*Note: The temperature sensor,  $V_{BAT/2}$  can only be used in the ADC1.*

### 9.3.5 Single conversion mode

The ADC can enter the single conversion mode by configuring ADC\_CTRL2.CTU to 0. In this mode, external triggering (for regular channels or injection channels) or setting ADC\_CTRL2.ON=1 (for regular channels only) can start the ADC to start conversion, and the ADC only performs one conversion.

After the conversion starts, when an injection channel conversion is completed, the injection channel conversion end flag (ADC\_STS.JENDC) will be set to 1. If the injection channel conversion end interrupt enable (ADC\_CTRL1.JENDCIEN) bit is set to 1, an interrupt will be generated at this time, and the converted data will be stored in the ADC\_JDAT<sub>x</sub> register.

After the conversion starts, when a regular channel conversion is completed, the regular channel conversion end flag (ADC\_STS.ENDC) will be set to 1. If the regular channel conversion end interrupt enable (ADC\_CTRL1.ENDCIEN) bit is set to 1, an interrupt will be generated at this time, and the converted data will be stored in the ADC\_DAT register.

After single conversion, the ADC stops.

### 9.3.6 Continuous conversion mode

The ADC can enter the continuous conversion mode by configuring ADC\_CTRL2.CTU to 1. In this mode, external triggering or setting ADC\_CTRL2.ON to 1 can start the ADC to start conversion, and the ADC will continuously convert the selected channel. Continuous mode is only valid for regular channels, not for injection channels.

After the conversion starts, when a regular channel conversion is completed, the regular channel end of conversion flag bit (ADC\_STS.ENDC) will be set to 1. If the regular channel conversion end interrupt enable bit (ADC\_CTRL1.ENDCIEN) is set to 1 at this time, an interrupt will be generated. The converted data will be stored in the ADC\_DAT register.

### 9.3.7 Timing diagram

When ADC\_CTRL2.ON is set to 1 for the first time, the ADC is powered on. After the ADC is powered on, the ADC needs a certain time ( $t_{STAB}$ ) to ensure its stability. After the ADC is stable, write 1 to ADC\_CTRL2.ON again, the ADC starts to convert, and the conversion end flag will be set to 1 after the conversion is completed.

Figure 9-5 Timing diagram

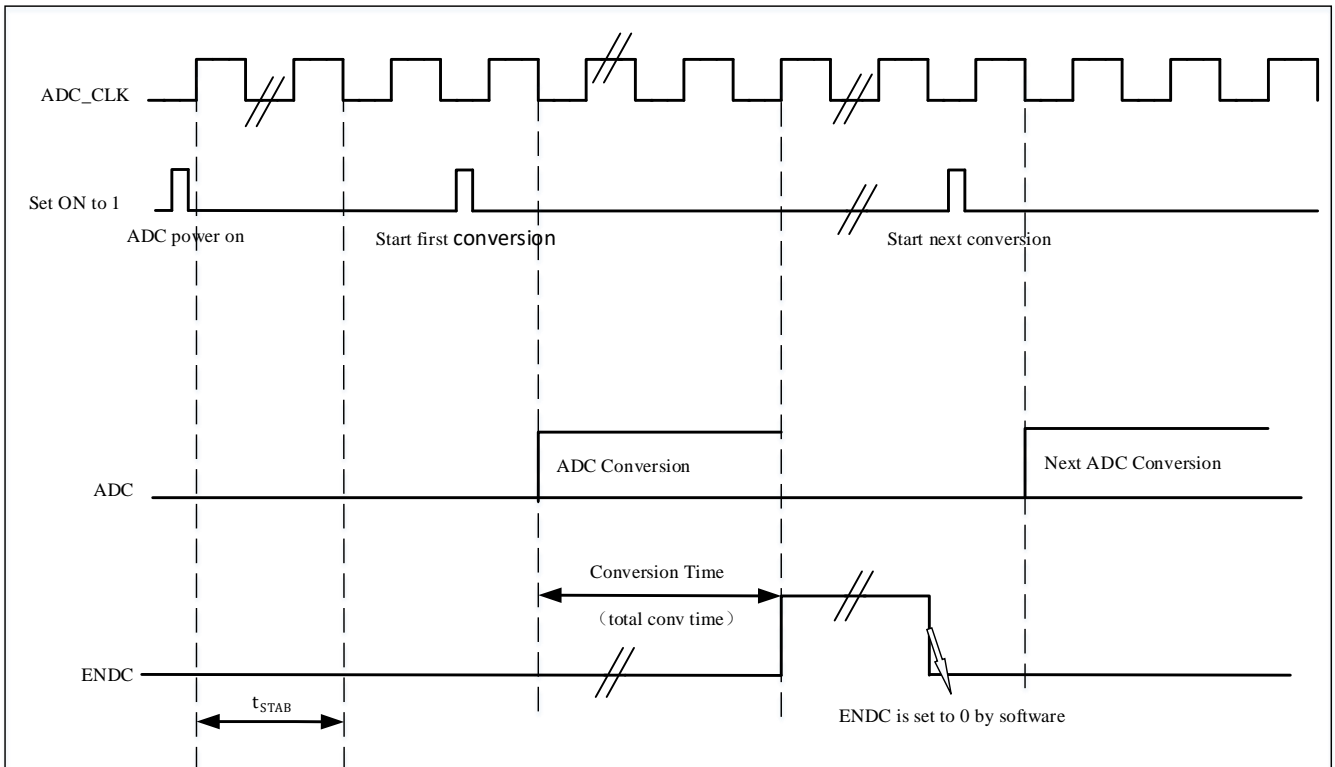

### 9.3.8 Analog watchdog

The analog watchdog can be enabled on the regular channel by setting ADC\_CTRL1.AWDGERCH to 1, or the analog watchdog on the injection channel can be enabled by setting ADC\_CTRL1.AWDGEJCH to 1. The high threshold of the analog watchdog can be set by configuring ADC\_WDGHIGH.HTH, and the low threshold of the analog watchdog can be set by configuring ADC\_WDGLOW.LTH. The threshold of the analog watchdog has nothing to do with the way of data alignment, because the comparison of the ADC's conversion value with the threshold is done before the alignment. When the value of ADC analog conversion is higher than the high threshold of the analog watchdog or lower than the low threshold of the analog watchdog, the analog watchdog flag (ADC\_STS.AWDG) will be set to 1, if ADC\_CTRL1.AWDGIEN has been configured to 1, an interrupt will be generated at this time. The analog watchdog can be controlled for one or more channels by configuring ADC\_CTRL1.AWDGSLEN and ADC\_CTRL1.AWDGCH[4:0].

Table 9-2 Analog watchdog channel selection

| Channel       | ADC_CTRL1 register control bit |          |          |
|---------------|--------------------------------|----------|----------|
|               | AWDGSLEN                       | AWDGERCH | AWDGEJCH |
| There is none | Any value                      | 0        | 0        |

|  |   |   |   |
|--|---|---|---|
| All injection channels                 | 0 | 0 | 1 |
| All regular channels                   | 0 | 1 | 0 |
| All injection and regular channels     | 0 | 1 | 1 |
| A single injection channel             | 1 | 0 | 1 |
| A single regulars of the channel       | 1 | 1 | 0 |
| A single injection or regular channels | 1 | 1 | 1 |

### 9.3.9 Scanning mode

By configuring ADC\_CTRL1.SCAMD to 1, the scan conversion mode can be turned on, and by configuring the four registers ADC\_RSEQ1, ADC\_RSEQ2, ADC\_RSEQ3, ADC\_JSEQ, the conversion sequence can be selected, and the ADC will scan and convert all the regular or Injected channels. After the conversion is started, the channels will be converted one by one. If ADC\_CTRL2.CTU is 1 at this time, the conversion will be restarted from the first channel of the conversion sequence after the conversion of all regular channels is completed. Injected channel does not support continuous mode. The DMA function can be turned on by setting ADC\_CTRL2.ENDDMA to 1, and the DMA will transfer the data to the SRAM after the regular channel conversion is completed.

*Note: In dual ADC mode, the DMA function on the regular channel of ADC2 needs to be completed by the DMA of ADC1, and the DMA function on the regular channel of ADC4 needs to be completed by the DMA of ADC3.*

### 9.3.10 Injection channel management

#### 9.3.10.1 Automatic injection

If ADC\_CTRL1.AUTOJC bit is set, then the Injected channels are automatically converted following the regular channels mentioned by ADC\_RSEQ and ADC\_JSEQx. A single trigger can convert up to 16+ 4 channels. Setting ADC\_CTRL2.CTU the conversion sequence will be converted continuously.

When this function is turned on, the external trigger of the injection channel needs to be turned off.

This function cannot be used with the discontinuous mode at the same time.

When the ADC clock prescale factor is 2, there is a delay of two ADC clock intervals when the conversion sequence changes from regular to injection or injection to regular. When the ADC clock prescale factor is 4 to 8, there is a delay of one ADC clock intervals when the conversion sequence changes from regular to injection or injection to regular.

#### 9.3.10.2 Trigger injection

Set ADC\_CTRL1.AUTOJC to 0 and ADC\_CTRL1.SCAMD to 1 to enable the trigger injection function. In this function, the regular channel of continuous conversion is triggered by setting ADC\_CTRL2.ON or by external trigger. When the regular channel is converted, if an external injection trigger is generated, the current conversion will be suspended, and the injection sequence channel will start conversion. When the injection sequence channel conversion is completed, the interrupted conversion of regular sequence channel will be resumed. If a regular event is generated during the injection conversion, the regular sequence channel will start conversion after the injection sequence channel conversion is completed.

When using this function, the time interval between the injection channel triggers needs to be greater than the time required for the injection sequence to complete the conversion.

Figure 9-6 Injection conversion delay

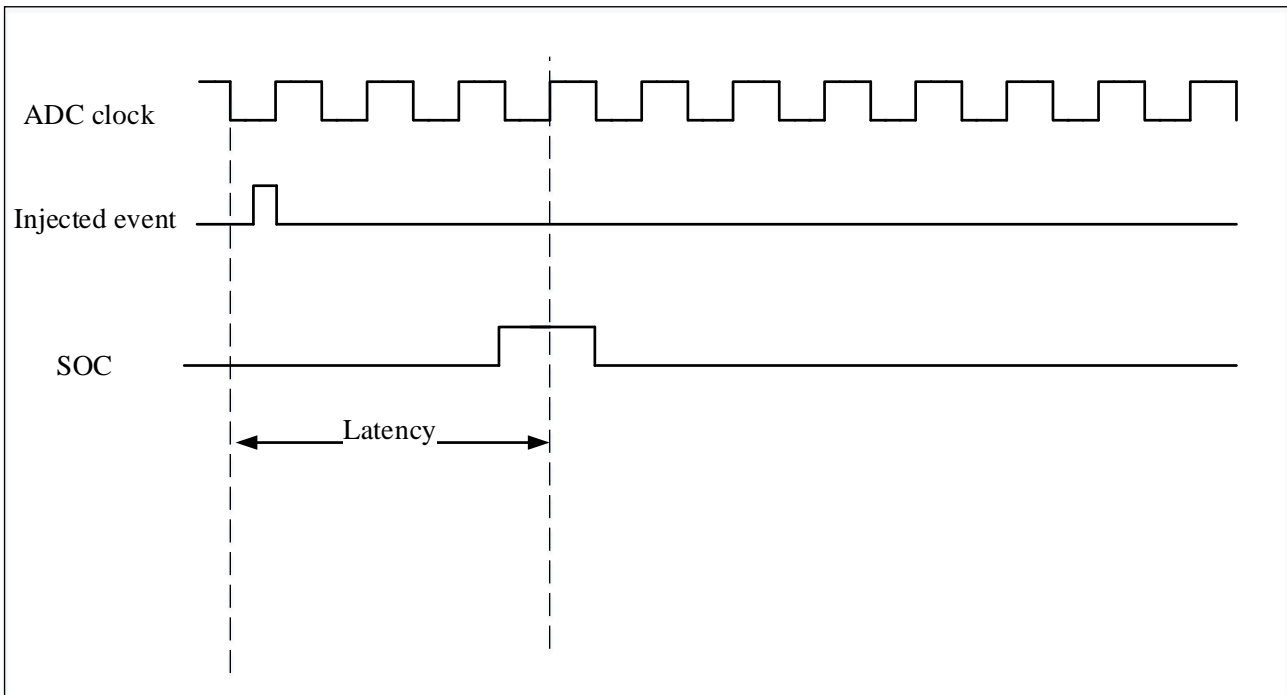

*Note: For the maximum delay value, please refer to the electrical characteristics section in the data manual.*

## 9.3.11 Discontinuous mode

### 9.3.11.1 Regular channels

Configure `ADC_CTRL1.DREGCH` to 1 to enable the discontinuous mode on the regular channel, obtain the regular sequence by configuring `ADC_RSEQ1`, `ADC_RSEQ2`, `ADC_RSEQ3`, and configure `ADC_CTRL1.DCTU[2:0]` to control the conversion of  $n$  channels each time a trigger signal is generated.

When the trigger signal is generated, it will convert  $n$  channels of the regular sequence and then stop, until the next trigger signal is generated. Next trigger will continue to convert  $n$  channels from the point where the previous conversion stopped, until all channels of the regular sequence are converted (If the last trigger occurs and the remaining channels in the conversion sequence are less than  $n$ , only the remaining channels will be converted and the conversion will be stopped), and the end of conversion flag bit will also be set to 1. When the conversion of all channels in the conversion sequence is completed, when the next trigger signal occurs, the conversion starts from the first channel of the regular sequence again.

### 9.3.11.2 Injection channels

Configure `ADC_CTRL1.DJCH` to 1 to enable the discontinuous mode on the injection channel, obtain the injection sequence by configuring `ADC_JSEQ`.

When the trigger signal is generated, it will convert 1 channel of the injection sequence and then stop. Until the next trigger signal is generated. Next trigger will continue to convert 1 channel from the point where the previous conversion stopped until all channels of the injection sequence are converted, and the end of conversion flag bit will also be set to 1. When the conversion of all channels in the conversion sequence is completed, when the next trigger

signal occurs ,the conversion starts from the first channel of the injection sequence again.

Only one of injection conversion and regular conversion can be set to discontinuous mode at the same time, and the automatic injection function and discontinuous mode cannot be set at the same time.

## 9.4 Calibration

In order to reduce the error, the ADC will have a built-in self-calibration mechanism. Before the A/D conversion, this self-calibration mechanism is used to calculate a calibration factor on each capacitor. Errors due to changes in the internal capacitor bank during conversion are eliminated by this calibration factor. The application program sets the ADC\_CTRL2.ENCAL bit to 1 to start self-calibration. During the calibration, the ADC\_CTRL2.ENCAL bit remains 1. After the calibration, the ADC\_CTRL2.ENCAL bit is cleared by hardware, and then the A/D conversion starts.

Note:

1. It is recommended to perform a calibration after each power-on. If the ADC has been converted and is in continuous conversion mode, the calibration operation cannot be completed..
2. The default is single-end calibration, and for differential automatic calibration, you must set ADC\_CTRL3.CALDIF to 1. Then write 1 to ADC\_CTRL2.ENCAL bit and wait for calibration to complete (ADC\_CTRL2.ENCAL bit will clear 0 automatically after calibration).

Figure 9-7 Calibration sequence diagram

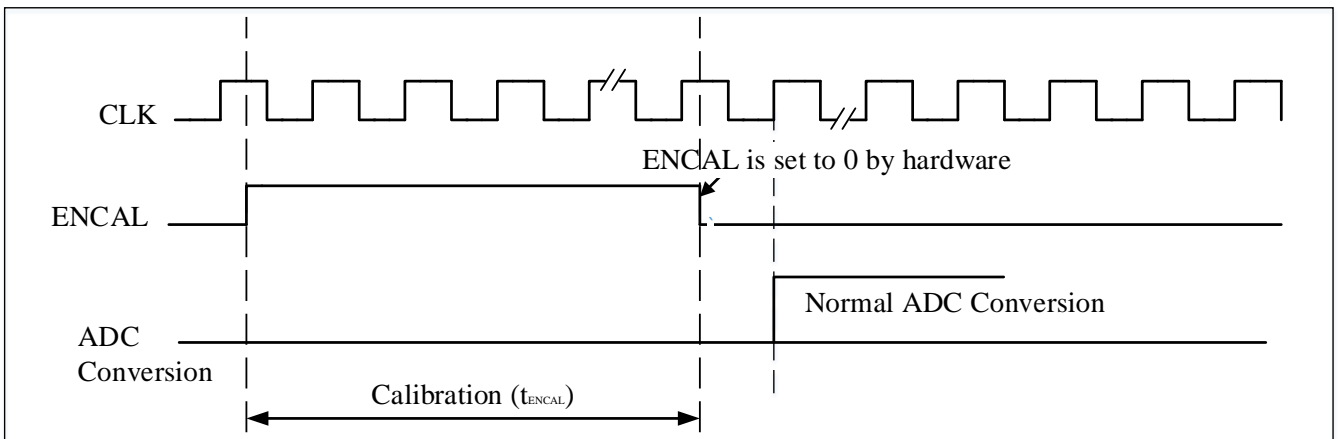

## 9.5 Data aligned

There are two alignment methods for data storage after conversion: left-aligned and right-aligned. The alignment can be set by the ADC\_CTRL2.ALIG bit. ADC\_CTRL2.ALIG = 0 is right-aligned, as shown in **Table 9-3**, ADC\_CTRL2.ALIG = 1 is left-aligned, as shown in **Table 9-4**.

For injection sequence , the SYM bit is the extended sign value, and the data stored in the register is the conversion result minus the user-defined offset in the ADC\_JOFFSETx register, so the result can be a negative value; for regular sequence , there is no need to subtract offset value.

Table 9-3 Right-align data

The Injection sequence

(12bit resolution)

|     |     |     |     |     |     |    |    |    |    |    |    |    |    |    |    |
|-----|-----|-----|-----|-----|-----|----|----|----|----|----|----|----|----|----|----|
| SYM | SYM | SYM | SYM | D11 | D10 | D9 | D8 | D7 | D6 | D5 | D4 | D3 | D2 | D1 | D0 |
|-----|-----|-----|-----|-----|-----|----|----|----|----|----|----|----|----|----|----|

The regular sequence

(12bit resolution)

|   |   |   |   |     |     |    |    |    |    |    |    |    |    |    |    |
|---|---|---|---|-----|-----|----|----|----|----|----|----|----|----|----|----|
| 0 | 0 | 0 | 0 | D11 | D10 | D9 | D8 | D7 | D6 | D5 | D4 | D3 | D2 | D1 | D0 |
|---|---|---|---|-----|-----|----|----|----|----|----|----|----|----|----|----|

Table 9-4 Left-aligne data

Injection sequence

(12bit resolution)

|     |     |     |    |    |    |    |    |    |    |    |    |    |   |   |   |
|-----|-----|-----|----|----|----|----|----|----|----|----|----|----|---|---|---|
| SYM | D11 | D10 | D9 | D8 | D7 | D6 | D5 | D4 | D3 | D2 | D1 | D0 | 0 | 0 | 0 |
|-----|-----|-----|----|----|----|----|----|----|----|----|----|----|---|---|---|

The regular sequence

(12bit resolution)

|     |     |    |    |    |    |    |    |    |    |    |    |   |   |   |   |
|-----|-----|----|----|----|----|----|----|----|----|----|----|---|---|---|---|
| D11 | D10 | D9 | D8 | D7 | D6 | D5 | D4 | D3 | D2 | D1 | D0 | 0 | 0 | 0 | 0 |
|-----|-----|----|----|----|----|----|----|----|----|----|----|---|---|---|---|

*Note: When the conversion digits are 10, 8, and 6, refer to the alignment with 12 conversion digits*

## 9.6 Programmable channel sampling time

Specify the number of sampling cycles of ADC in ADC\_SAMPTx.SAMPx[2:0], and then the ADC samples the input voltage in the specified sampling cycle. For different channels, you can select different sampling time. The total conversion time is calculated as follows:

$$T_{CONV} = \text{Sampling time} + 12.5 \text{ cycles}$$

Example:

ADCCLK=72MHz, the sampling time is 1.5 cycles and resolution is 12bit, the total conversion time is "1.5 + 12.5" ADCCLK cycles, that is:

$$T_{CONV} = 1.5 + 12.5 = 14 \text{ cycles} = 0.1944\mu\text{s}$$

*Note: An additional 3 cycles are required for the first conversion in continuous conversion mode and for each conversion in single conversion mode.*

*Example:*

*Single conversion mode, ADCCLK=72MHz, the sampling time is 1.5 cycles and resolution is 12bit:*

$$T_{CONV} = 3 + 1.5 + 12.5 = 17 \text{ cycles} = 0.2361\mu\text{s}$$

*Continuous conversion mode, ADCCLK=72MHz, the sampling time is 1.5 cycles and resolution is 12bit:*

$$\text{First conversion: } T_{CONV} = 3 + 1.5 + 12.5 = 17 \text{ cycles} = 0.2361\mu\text{s}$$

$$\text{Second and subsequent conversion: } T_{CONV} = 1.5 + 12.5 = 14 \text{ cycles} = 0.1944\mu\text{s}$$

## 9.7 Externally triggered conversion

For the regular sequence, software sets the ADC\_CTRL2.EXTRTRIG bit to 1, then the regular channel can use the rising edge of the external event to trigger the start conversion, and then the software sets the ADC\_CTRL2.EXTRSEL[2:0] bits to select the external trigger source of the regular sequence. The external trigger source selection is shown in the table below. If you select EXTI line 11 or TIM8\_TRGO as the external trigger source, you can set the AFIO\_RMP\_CFG.ADC1\_ETRR or AFIO\_RMP\_CFG.ADC2\_ETRR bit to implement; If you select EXTI line 10 or TIM5\_CC3 as the external trigger source, you can set the AFIO\_RMP\_CFG4.ADC3\_ETRR or AFIO\_RMP\_CFG4.ADC4\_ETRR bit to implement; if you select SWSTRRCH as the external trigger source, you can start the regular channel conversion by setting ADC\_CTRL2.SWSTRRCH to 1.

Table 9-5 External trigger for regular channels of ADC1 and ADC2

| EXTRSEL[2:0] | Trigger source              | Type  |
|--------------|-----------------------------|---|
| 000          | TIM1_CC1 event              | Internal signal from the on-chip timer          |
| 001          | TIM1_CC2 event              |   |
| 010          | TIM1_CC3 event              |   |
| 011          | TIM2_CC2 event              |   |
| 100          | TIM3_TRGO event             |   |
| 101          | TIM4_CC4 event              |   |
| 110          | EXTI line11/TIM8_TRGO event | External pin/internal signal from on-chip timer |
| 111          | SWSTRRCH                    | Software control bit                            |

Table 9-6 External trigger for regular channels of ADC3 and ADC4

| EXTRSEL [2:0] | Trigger source             | Type  |
|---------------|----------------------------|---|
| 000           | TIM3_CC1 event             | Internal signal from the on-chip timer          |
| 001           | TIM2_CC3 event             |   |
| 010           | TIM1_CC3 event             |   |
| 011           | TIM8_CC1 event             |   |
| 100           | TIM8_TRGO event            |   |
| 101           | TIM5_CC1 event             |   |
| 110           | EXTI line10/TIM5_CC3 event | External pin/internal signal from on-chip timer |
| 111           | SWSTRRCH                   | Software control bit                            |

For the injection sequence, the software sets the ADC\_CTRL2.EXTJTRIG bit to 1, then the injection channel can use the rising edge of the external event to trigger the start conversion, and the software sets the ADC\_CTRL2.EXTJSEL[2:0] bits to select the external trigger source of the injection sequence. The external trigger source selection is shown in the table below. If you select EXTI line 15 or TIM8\_CC4 as the external trigger source, you can set the AFIO\_RMP\_CFG.ADC1\_ETRI or AFIO\_RMP\_CFG.ADC2\_ETRI bit to implement; If you select EXTI line 14 or TIM5\_CC4 as the external trigger source, you can set the AFIO\_RMP\_CFG4.ADC3\_ETRI or AFIO\_RMP\_CFG4.ADC4\_ETRI bit to implement; if you select SWSTRJCH as the external trigger source, you can start the injection channel conversion by setting ADC\_CTRL2.SWSTRJCH to 1.

Table 9-7 External trigger for injection channel of ADC1 and ADC2

| EXTJSEL[2:0] | Trigger source             | Type  |
|--------------|----------------------------|---|
| 000          | TIM1_TRGO event            | Internal signal from the on-chip timer          |
| 001          | TIM1_CC4 event             |   |
| 010          | TIM2_TRGO event            |   |
| 011          | TIM2_CC1 event             |   |
| 100          | TIM3_CC4 event             |   |
| 101          | TIM4_TRGO event            |   |
| 110          | EXTI line15/TIM8_CC4 event | External pin/internal signal from on-chip timer |
| 111          | SWSTRJCH                   | Software control bit                            |

Table 9-8 External trigger for injection channel of ADC3 and ADC4

| EXTJSEL[2:0] | Trigger source             | Type                                   |
|--------------|----------------------------|--|
| 000          | TIM1_TRGO event            | Internal signal from the on-chip timer |
| 001          | TIM1_CC4 event             |  |
| 010          | TIM4_CC3 event             |  |
| 011          | TIM8_CC2 event             |  |
| 100          | TIM8_CC4 event             |  |
| 101          | TIM5_TRGO event            |  |
| 110          | EXTI line14/TIM5_CC4 event | Software control bit                   |
| 111          | SWSTRJCH                   |  |

Note: Injection triggers can interrupt conversion of the regular sequence.

## 9.8 DMA requests

In order to avoid the loss of the regular channel conversion result saved in the ADC\_DAT register due to excessive data when multiple regular channels are converted, the ADC\_CTRL2.ENDMA bit can be set to 1 to use DMA. When the ADC regular channel conversion ends, a DMA request is generated. After the DMA receives the request, it will transfer the converted data from the ADC\_DAT register to the destination address specified by the user.

Note: In independent ADC mode, ADC1, ADC2, ADC3, ADC4 have DMA function. In dual ADC mode, the data converted by ADC2 is in the data register of ADC1, and the data converted by ADC4 is in the data register of ADC3.

## 9.9 ADC Mode

ADC1 (master) and ADC2 (slave), ADC3 (master) and ADC4 (slave) can form a dual ADC mode.

The ADC working mode can be selected by configuring ADC\_CTRL1.DUSEL[3:0], which can be configured as independent mode or dual ADC mode. The ADC mode can be configured as the following working modes:

- Independent mode.
- Synchronous injection mode.
- Synchronous regular mode.
- Fast alternate mode.

- Slow alternate mode.
- Rotation trigger mode.
- Synchronous regular mode + synchronous injection mode.
- Synchronous regular mode + rotation trigger mode.
- Synchronous injection mode + alternate mode.

Note:

1. When configuring dual ADC mode, if external event trigger is required, it is necessary to configure the main ADC external event trigger, the slave ADC software trigger, the master ADC and the slave ADC external trigger must be enabled at the same time, so as to avoid the wrong trigger conversion of the slave ADC.

2. When working in dual ADC mode, even if DMA is not used to transfer data, DMA needs to be enabled, and the converted data from the ADC can be read through the data register of the main ADC.

Figure 9-8 Dual ADC Block Diagram

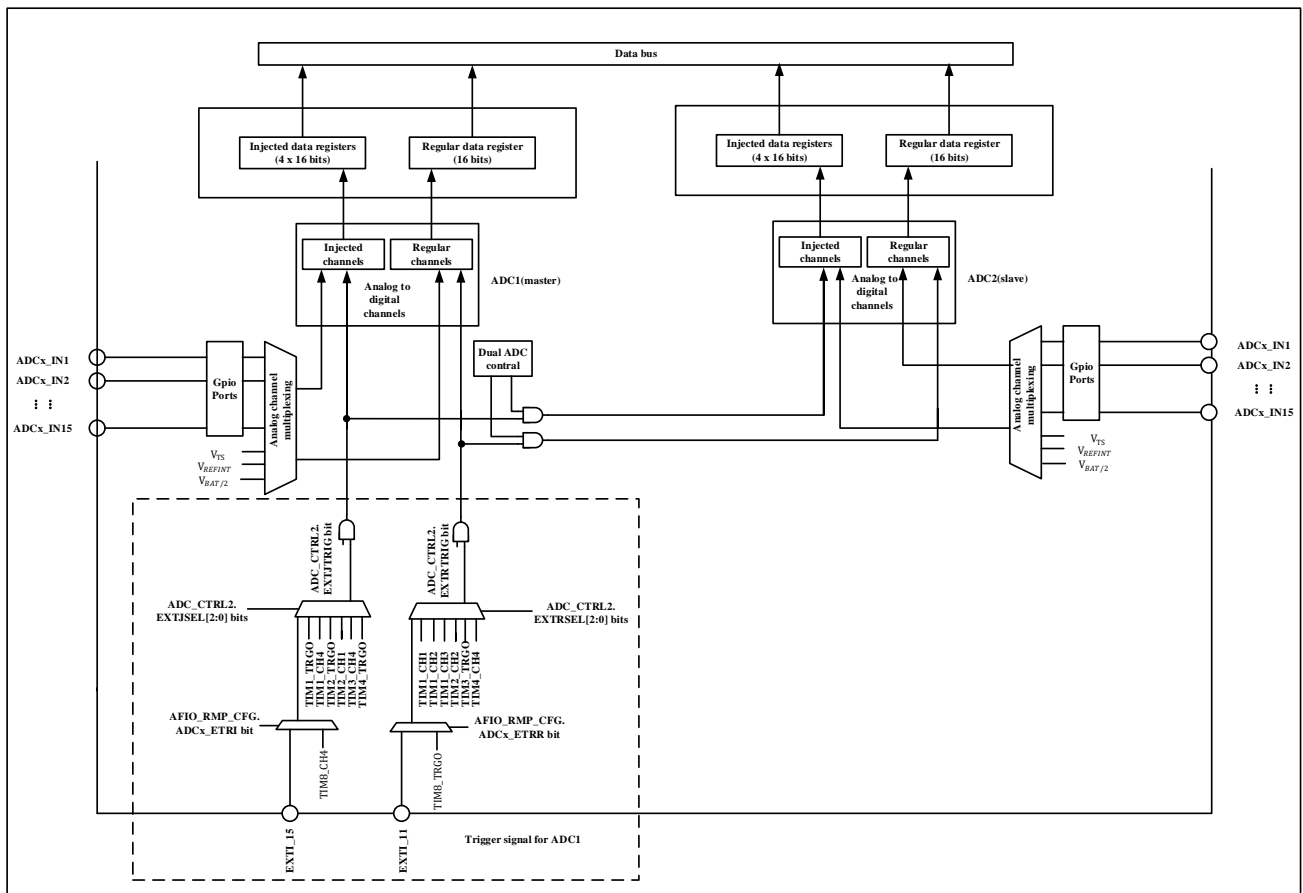

## 9.9.1 Independent mode

In this mode, each ADC works independently.

## 9.9.2 Synchronous regular mode

In this mode, a regular sequence is converted, and the external trigger comes from the multiplexer of ADC1, which is determined by ADC\_CTRL2.EXTRSEL[2:0], and ADC2 will be triggered synchronously.

If ADC1 or ADC2 sets ADC\_CTRL1.ENDCIEN, when the conversion of the regular sequence of ADC1 or ADC2 is completed, an ENDC interrupt will be generated, and the converted data will be stored in the ADC\_DAT register. The high half word of ADC\_DAT is the conversion data of ADC2. The low half word of ADC\_DAT is the conversion data of ADC1, and 32-bit DMA can be used to transfer the data of ADC\_DAT to SRAM.

*Note:*

1. Do not convert the same channel on 2 ADCs (the sampling times of two ADCs on the same channel cannot overlap).
2. In the synchronous regular mode, the synchronous conversion regular sequence of ADC1 and ADC2 needs to be set to the same time, or the interval of the trigger signal is longer than the sequence with longer conversion time. If the interval between the trigger signals is smaller than the conversion of the longer sequence, the shorter sequence may start to convert again when the longer sequence is not completed.

Figure 9-9 Schematic diagram of synchronous regular mode conversion of 16 channels

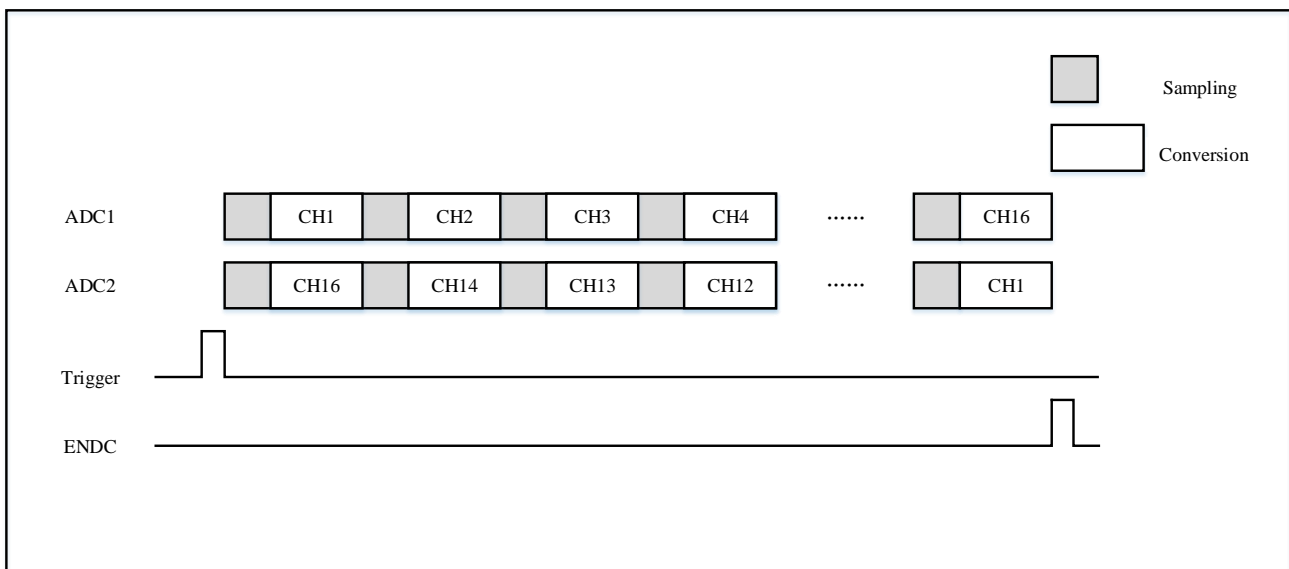

## 9.9.3 Synchronous injection mode

Converting an injection sequence in this mode, the external trigger comes from the multiplexer of ADC1, determined by ADC\_CTRL2.EXTJSEL[2:0], ADC2 will be triggered synchronously.

If ADC1 or ADC2 sets ADC\_CTRL1.JENDCIEN, a JENDC interrupt will be generated when the injection sequence of ADC1 and ADC2 is converted, and the converted data will be stored in the respective ADC\_JDATx registers.

*Note:*

1. Do not convert the same channel on 2 ADCs (the sampling times of two ADCs on the same channel cannot overlap).
2. In the synchronous injection mode, the injection sequence of the synchronous conversion of ADC1 and ADC2 needs to be set to the same time, or the interval of the trigger signal is longer than the sequence with a longer

conversion time. If the interval between the trigger signals is smaller than the conversion of the longer sequence, the shorter sequence may start to convert again when the longer sequence is not completed.

Figure 9-10 Schematic diagram of synchronous injection mode conversion of 4 channels

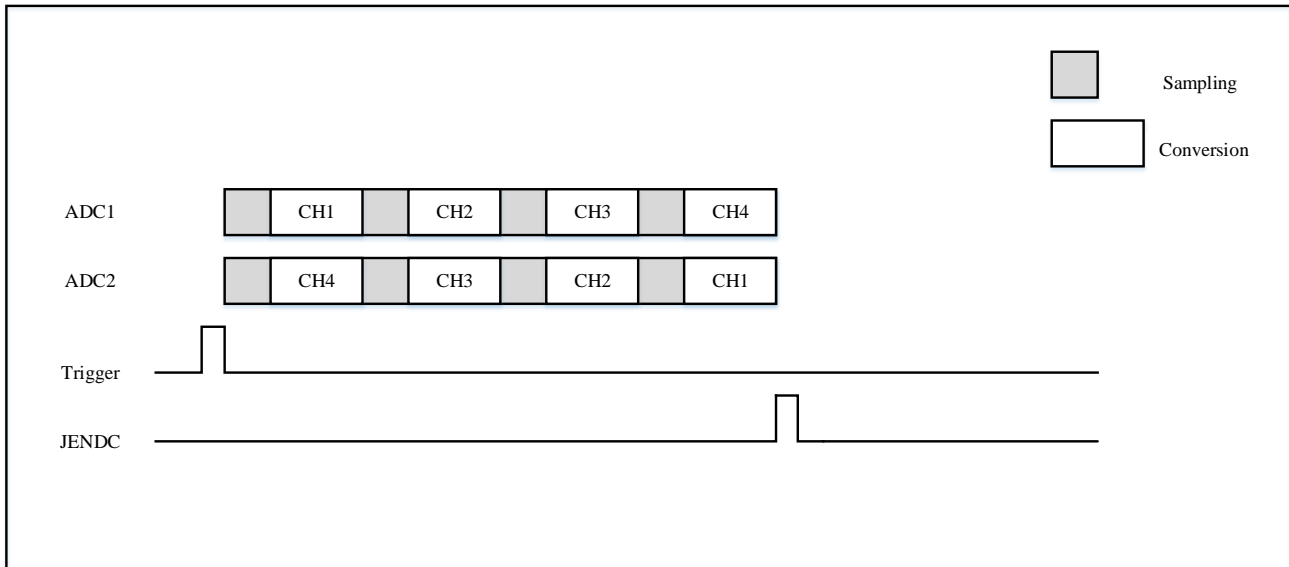

### 9.9.4 Fast alternate mode

This mode is for regular sequences (usually one channel). The external trigger comes from the multiplexer of ADC1, which is determined by `ADC_CTRL2.EXTRSEL[2:0]`. When the trigger occurs, ADC2 converts immediately and ADC1 starts converting after 7 ADC clock cycles. If `ADC_CTRL2.CTU` is set for ADC1 and ADC2, then the selected regular sequence will be converted continuously.

The converted data will be stored in the `ADC_DAT` register. The high halfword of `ADC_DAT` is the conversion data of ADC2, and the low halfword of `ADC_DAT` is the conversion data of ADC1. If ADC1 or ADC2 sets `ADC_CTRL1.ENDCIEN`, when the conversion of the regular sequence of ADC1 or ADC2 is completed, an ENDC interrupt will be generated. At this time, if `ADC_CTRL2.ENDMA` is set, a DMA transfer request can be generated, and the data of `ADC_DAT` can be passed through DMA transfers to SRAM.

*Note:*

1. When using fast alternate mode, make sure that no injection channel is externally triggered.
2. The sampling time must be less than 7 ADC clock cycles to avoid overlapping sampling cycles when ADC1 and ADC2 convert the same channel.

Figure 9-11 Schematic diagram of fast alternate mode conversion for continuous conversion of 1 channel

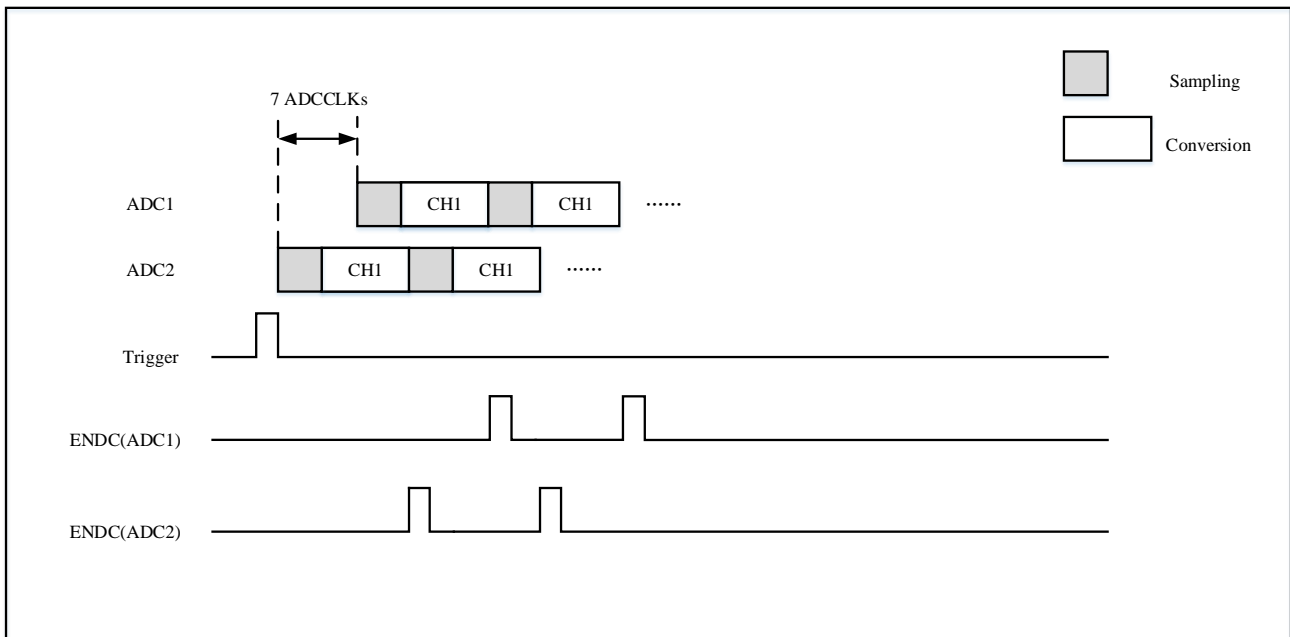

### 9.9.5 Slow alternate mode

This mode is for regular sequences (usually one channel). The external trigger comes from the multiplexer of ADC1, which is determined by `ADC_CTRL2.EXTRSEL[2:0]`. When the trigger is generated, ADC2 converts immediately, ADC1 starts to convert after 14 ADC clock cycles, ADC2 starts to convert again after 14 ADC clock cycles, and so on. This mode automatically continuously converts the regular sequence without the need to set `ADC_CTRL2.CTU`.

The converted data will be stored in the `ADC_DAT` register. The high half word of `ADC_DAT` is the conversion data of ADC2, and the low half word of `ADC_DAT` is the converted data of ADC1. If ADC1 or ADC2 sets `ADC_CTRL1.ENDCIEN`, when the conversion of the regular sequence of ADC1 or ADC2 is completed, an ENDC interrupt will be generated. At this time, if `ADC_CTRL2.ENDMA` is set, a DMA transfer request can be generated, and the data of `ADC_DAT` can be transferred to SRAM through DMA.

*Note:*

1. When using slow alternate mode, make sure that no injection channel is externally triggered.
2. The sampling time must be less than 14 ADC clock cycles to avoid overlapping sampling cycles when ADC1 and ADC2 convert the same channel.

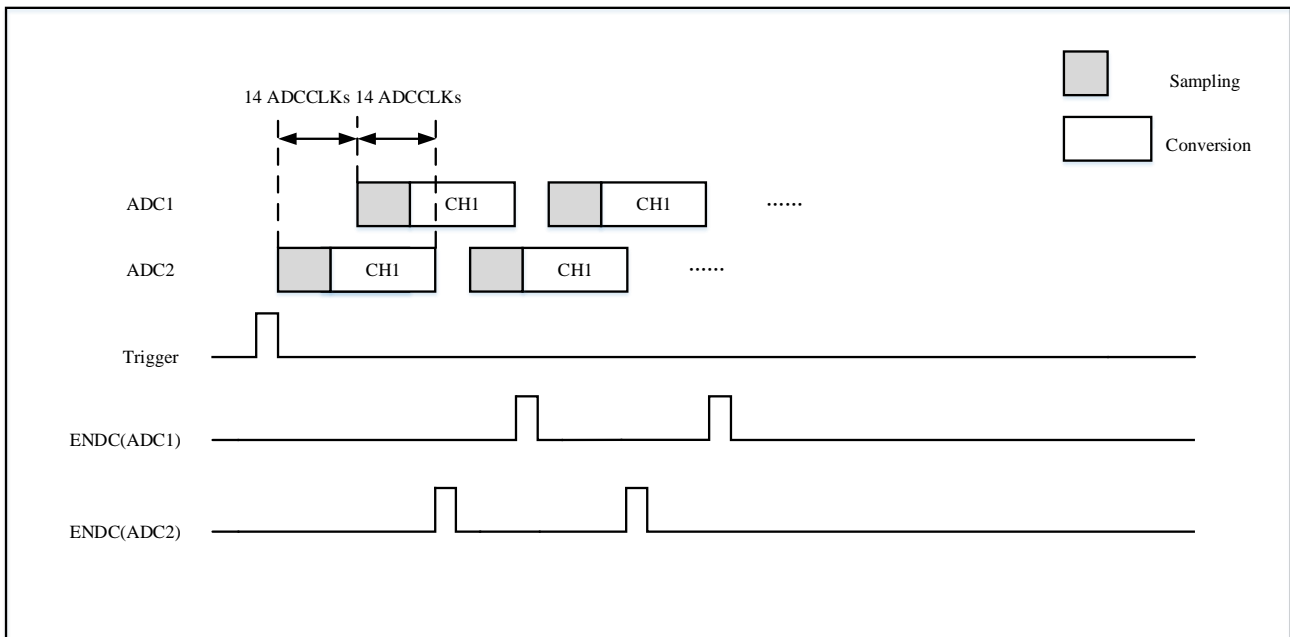
Figure 9-12 Schematic diagram of slow *alternate* mode conversion for 1 channel

## 9.9.6 Rotation trigger Mode

This mode is suitable for injection sequences. The external trigger comes from the multiplexer of ADC1, which is determined by `ADC_CTRL2.EXTJSEL[2:0]`. When the first trigger is generated, all injection channels of ADC1 are converted, when the second trigger is generated, all injection channels of ADC2 are converted, and so on. If ADC1 or ADC2 sets `ADC_CTRL1.JENDCIEN`, a JENDC interrupt will be generated when the conversion of the injection sequence of ADC1 or ADC2 is completed. When all injection sequences have been converted, another external trigger is generated, and the rotation trigger starts again.

Figure 9-13 Rotation triggering: injecting channel groups

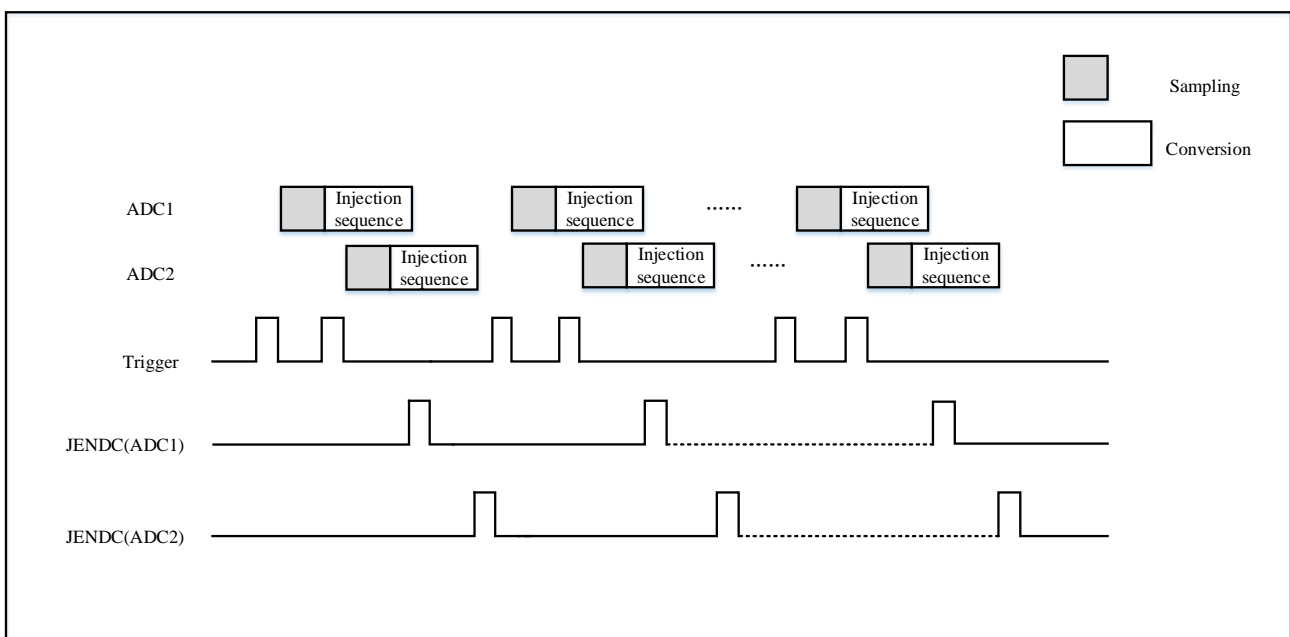

If the injection discontinuous mode is used on ADC1 and ADC2 at the same time, when the first trigger is generated, the first group of injection channels of ADC1 is converted; when the second trigger is generated, the first group of injection channels of ADC2 is converted; when the third trigger is generated, the second group of injection channels of ADC1 is converted. When the fourth trigger is generated, the second group of injection channels of ADC2 is converted, and the cycle is continues. If ADC1 or ADC2 sets ADC\_CTRL1.JENDCIEN, a JENDC interrupt will be generated when the conversion of the injection sequence of ADC1 or ADC2 is completed. When all injection sequences have been converted, another external trigger is generated, and the rotation trigger starts again.

Figure 9-14 Rotation trigger: inject channel group in discontinuous mode

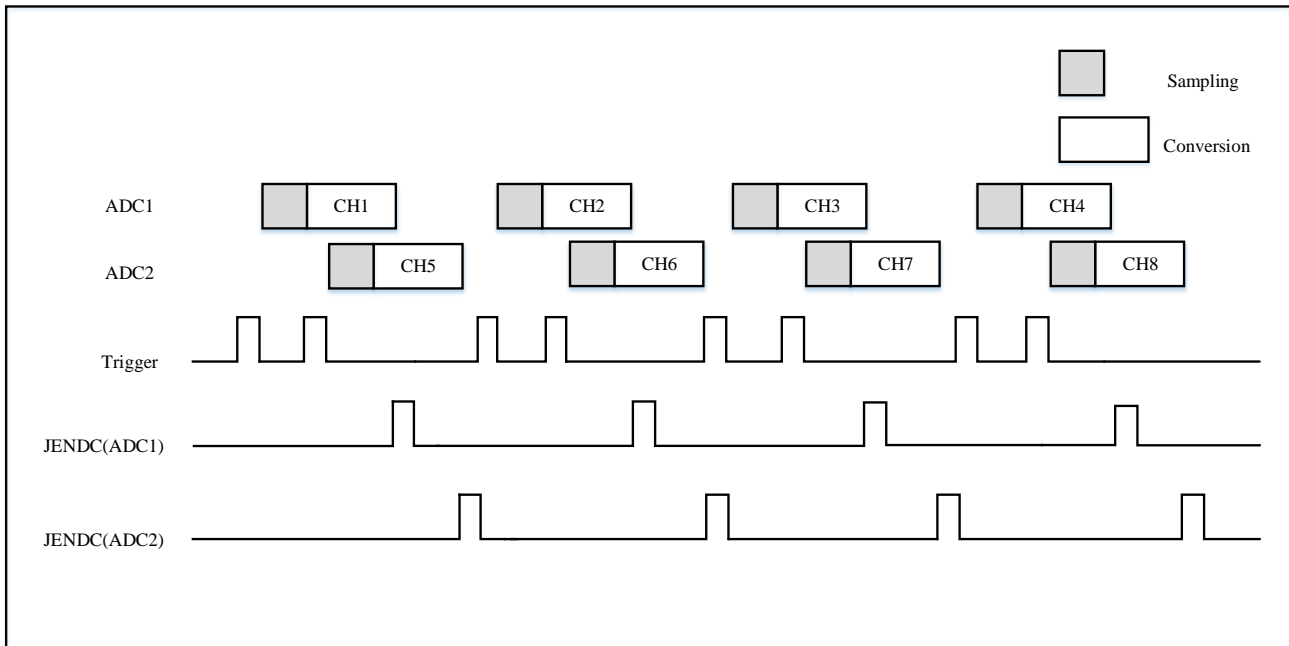

### 9.9.7 Mixed synchronous regular mode + synchronous injection mode

In this mode, the transition of the synchronous injection channel can interrupt the transition of the synchronous regular channel.

*Note: In this mode, the sequence of synchronous conversion of ADC1 and ADC2 needs to be set to the same time, or the interval of the trigger signal is greater than that of the sequence with longer conversion time. If the interval between the trigger signals is smaller than the conversion of the longer sequence, the shorter sequence may start to convert again when the longer sequence is not completed.*

### 9.9.8 Mixed synchronous regular mode + rotation trigger mode

Rotation triggered transitions of the injection channel can interrupt transitions of a synchronous regular channel.

When the injection channel event occurs, the injection rotation conversion starts immediately. If a regular conversion is in progress, both the master ADC and the slave ADC will stop the regular conversion to ensure that the regular conversion can be resumed synchronously after the injection conversion is completed.

*Note: In this mode, the sequence of synchronous conversion of ADC1 and ADC2 needs to be set to the same time, or the interval of the trigger signal is greater than that of the sequence with longer conversion time. If the interval between the trigger signals is smaller than the conversion of the longer sequence, the shorter sequence may start to*

convert again when the longer sequence is not completed.

Figure 9-15 Combination of rotation mode and synchronous regular mode

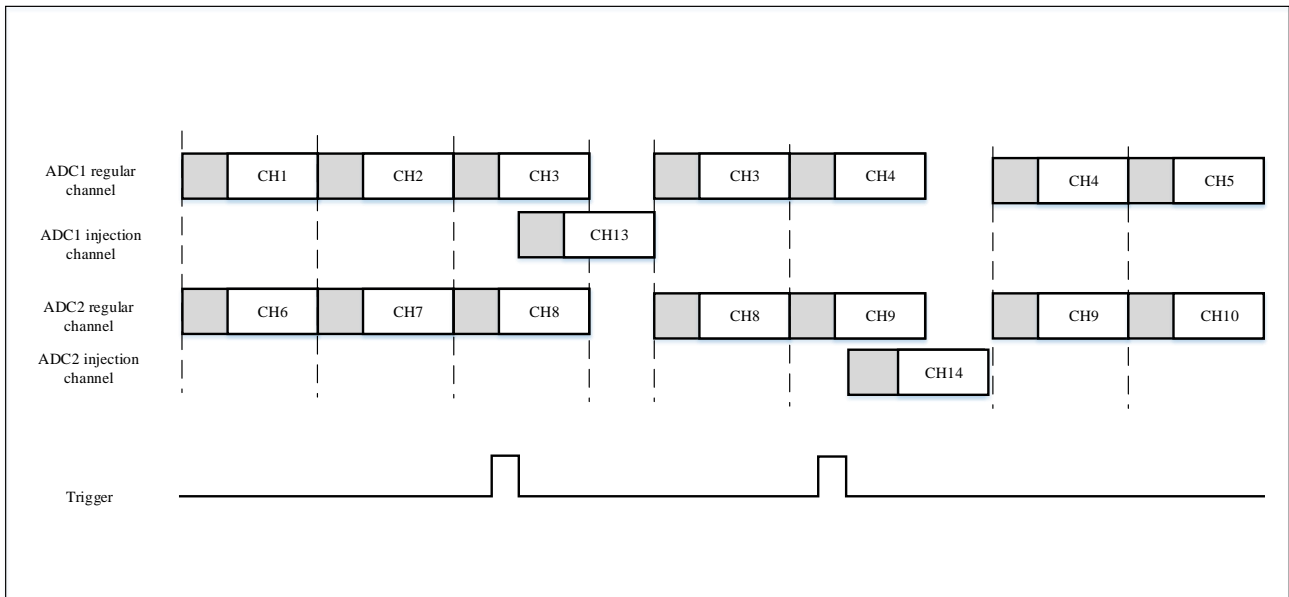

If another injection trigger occurs during the injection transition, this trigger will be ignored. As shown below:

Figure 9-16 Injection trigger occurs during injection transition

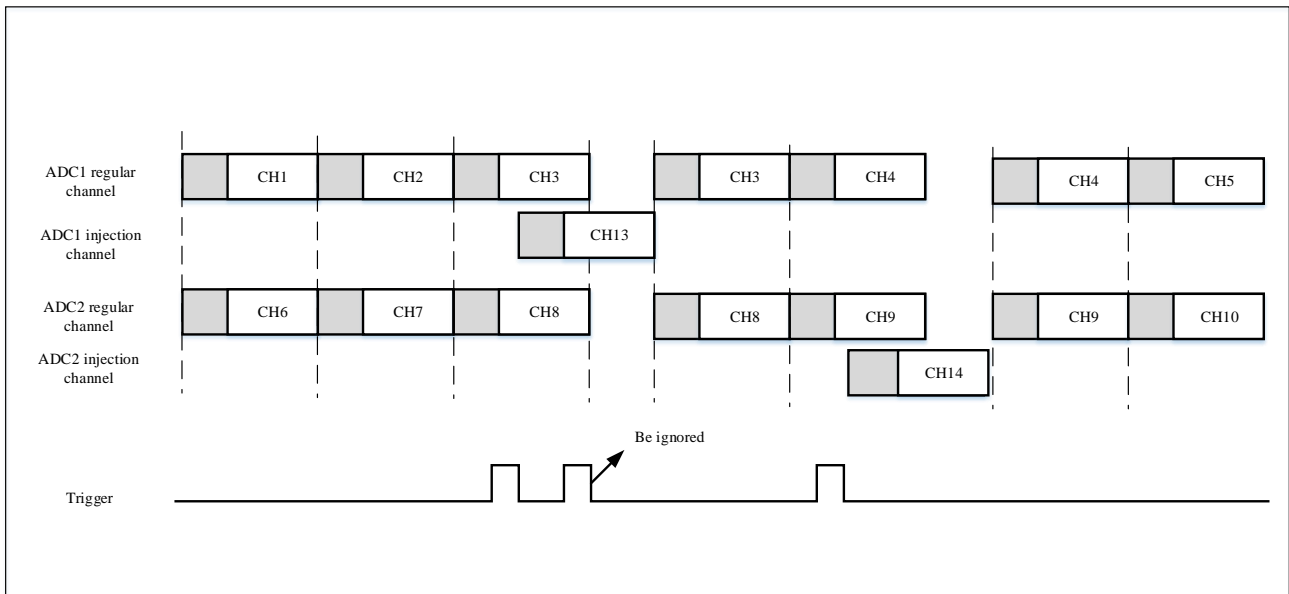

### 9.9.9 Mixed synchronous injection mode + alternate mode

In this mode, when the injection trigger occurs, the alternate conversion will be interrupted, the injection conversion will be started, and the alternate conversion will be resumed after the injection conversion is completed.

*Note: When the ADC clock prescale factor is set to 4, the sampling time will not be evenly distributed after the alternate mode recovery, and the sampling interval is 8 ADC clock cycles alternated with 6 ADC clock cycles instead of 7 ADCs evenly clock cycle.*

Figure 9-17 Alternate single-channel conversions are interrupted by injection sequences CH3 and CH4

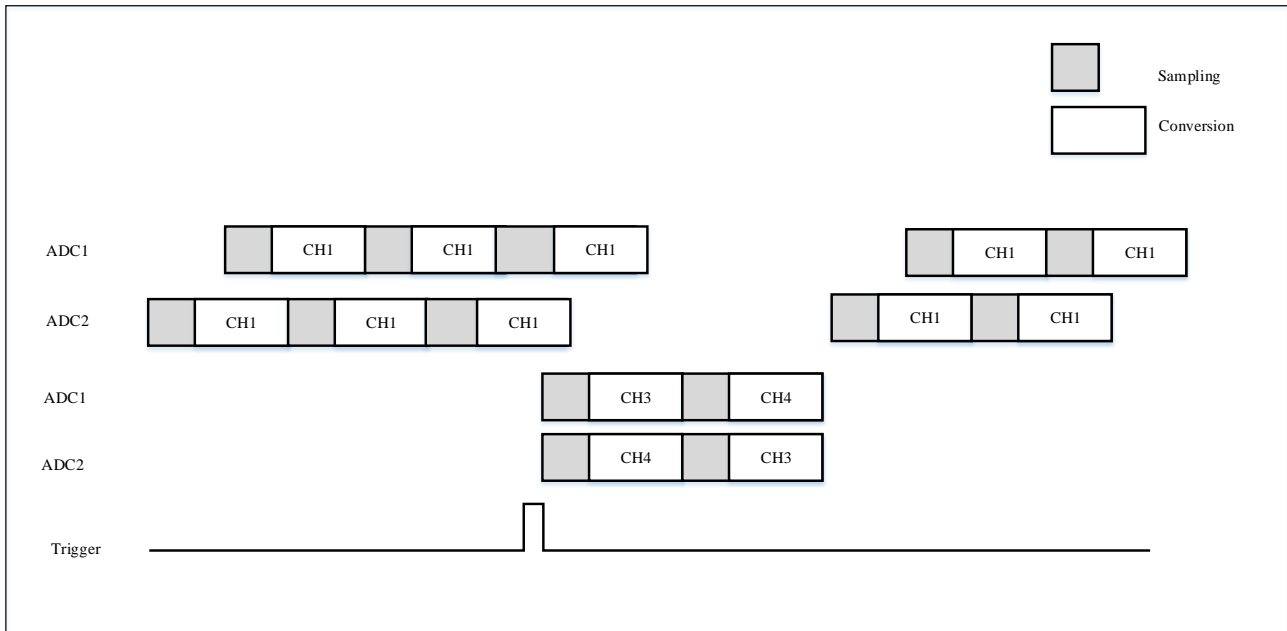

## 9.10 Temperature sensor

Set the ADC\_CTRL2.TEMPEN bit to 1, enable the temperature sensor and  $V_{REFINT}$ , and use the temperature sensor to detect the ambient temperature when the device is working. The output voltage sampled by the temperature sensor is converted into a digital value by the ADC\_IN16 channel. When the temperature sensor is working, the ideal sampling time is 17.1us; when the temperature sensor is not working, the ADC\_CTRL2.TEMPEN bit can be cleared by software to reduce power consumption. As follows is a block diagram of a temperature sensor.

The output voltage of the temperature sensor changes linearly with temperature. Different chips will have different offsets in the temperature curve due to different production processes. Through testing, it is found that the maximum offset is 3°C. This characteristic makes the internal temperature sensor more suitable for detecting temperature changes. Not suitable for measuring absolute temperature. When accurate temperature measurement is required, an external temperature sensor should be used.

Figure 9-18 Temperature sensor and VREFINT diagram of the channel

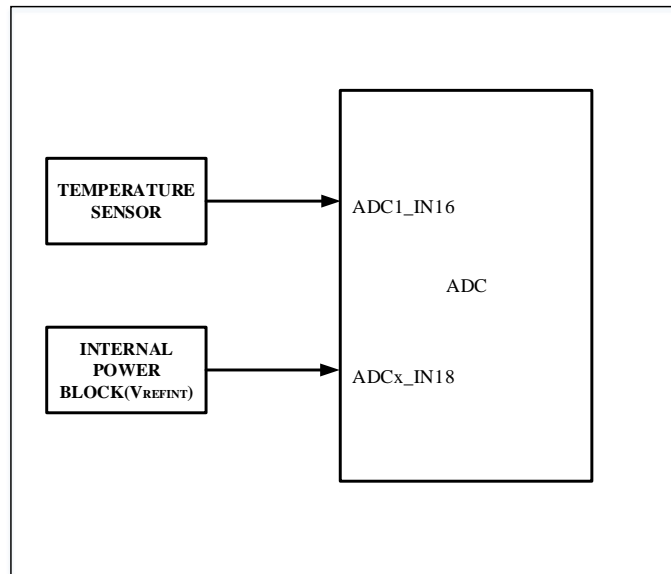

### 9.10.1 Temperature sensor using flow

- 1) Configure the channel (ADC\_IN16) and sampling time of the channel to be 17.1 us
- 2) Set ADC\_CTRL2.TEMPEN bit to 1 to enable temperature sensor and  $V_{REFINT}$
- 3) Set ADC\_CTRL2.ON bit to 1 to start ADC conversion (or through external trigger)
- 4) Read the temperature data in the ADC data register, and calculate the temperature value by the following formula:

$$\text{Temperature } (^{\circ}\text{C}) = \{(V_{30} - V_{SENSE}) / \text{Avg\_Slope}\} + 30 - T_{\text{offset}}$$

In which:

$V_{30} = V_{SENSE}$  at 30 degrees celsius

Avg\_Slope = temperature and Average slope of a  $V_{SENSE}$  curve (mV/ $^{\circ}\text{C}$  or  $\mu\text{V}/^{\circ}\text{C}$ )

$T_{\text{offset}}$  = empirical value for temperature error compensation ( $^{\circ}\text{C}$ )

Refer to the values of  $V_{30}$  and Avg\_Slope in the electrical characteristics chapter of the datasheet.

*Note: There is a settling time before the sensor wakes up from the power-off mode to the correct output of  $V_{SENSE}$ ; there is also a settling time after the ADC is powered on, so in order to shorten the delay, the ADC\_CTRL2.TEMPEN and ADC\_CTRL2.ON bits should be set at the same time.*

## 9.11 ADC interrupt

ADC interrupts can be from an end of regular or injection sequence conversion, an analog watchdog event when input voltage exceeds the threshold, any end of regular or injection channel conversion. These interrupts have independent interrupt enable bits.

There are 2 status flags in the ADC\_STS register: injection sequence channel conversion started (JSTR) and regular sequence channel conversion started (STR). But there are no interrupts associated with these two flags in the ADC.

Note: ADC1 and ADC2 share one interrupt entry, while ADC3 and ADC4 share one interrupt entry.

Table 9-9 ADC interrupt

| Interrupt event                                      | Event flags | Enable control bit |
|--|-------------|--------------------|
| Regular sequence or injection conversion is complete | ENDC        | ENDCIEN            |
| Injection sequence conversion is complete            | JENDC       | JENDCIEN           |
| Analog watchdog status bit is set                    | AWDG        | AWDGIEN            |
| Any regular channel interruption is enabled          | ENDCA       | ENDCAIEN           |
| Any injection channel interruption is enabled        | JENDCA      | JENDCAIEN          |

## 9.12 ADC registers

### 9.12.1 ADC register overview

Table 9-10 ADC register overview

| Offset | Register     | 31       | 30         | 29 | 28 | 27         | 26         | 25 | 24         | 23 | 22          | 21         | 20       | 19          | 18           | 17 | 16          | 15         | 14        | 13          | 12         | 11         | 10          | 9          | 8      | 7                | 6          | 5   | 4           | 3          | 2    | 1           | 0 |   |   |   |   |   |   |   |   |   |   |   |   |   |   |   |   |   |   |   |   |   |
|--------|--------------|----------|------------|----|----|------------|------------|----|------------|----|-------------|------------|----------|-------------|--------------|----|-------------|------------|-----------|-------------|------------|------------|-------------|------------|--------|------------------|------------|-----|-------------|------------|------|-------------|---|---|---|---|---|---|---|---|---|---|---|---|---|---|---|---|---|---|---|---|---|---|
| 000h   | ADC_STS      | Reserved |            |    |    |            |            |    |            |    |             |            |          |             |              |    |             |            |           |             |            |            |             |            |        | JENDCA           | ENDCA      | STR | JSTR        | JENDC      | ENDC | AWDG        |   |   |   |   |   |   |   |   |   |   |   |   |   |   |   |   |   |   |   |   |   |   |
|        | Reset Value  | 0        |            |    |    |            |            |    |            |    |             |            |          |             |              |    |             |            |           |             |            |            |             |            |        | 0                | 0          | 0   | 0           | 0          | 0    |             |   |   |   |   |   |   |   |   |   |   |   |   |   |   |   |   |   |   |   |   |   |   |
| 004h   | ADC_CTRL1    | Reserved |            |    |    |            |            |    |            |    | AWDGERCH    | AWDGEJCH   | Reserved | DUSEL       | DCTU         |    |             | DJCH       | DREGCH    | AUTOIC      | AWDGSGLN   | SCANMD     | JENDCIEN    | AWDGIEN    | ENDIEN | AWDGCH           |            |     |             |            |      |             |   |   |   |   |   |   |   |   |   |   |   |   |   |   |   |   |   |   |   |   |   |   |
|        | Reset Value  | 0        |            |    |    |            |            |    |            |    | 0           | 0          | 0        | 0           | 0            | 0  | 0           | 0          | 0         | 0           | 0          | 0          | 0           | 0          | 0      | 0                | 0          | 0   | 0           | 0          | 0    | 0           | 0 | 0 | 0 | 0 |   |   |   |   |   |   |   |   |   |   |   |   |   |   |   |   |   |   |
| 008h   | ADC_CTRL2    | Reserved |            |    |    |            |            |    |            |    | TEMPEN      | SWSTRRCH   | SWSTRJCH | EXTRTRIG    | EXTRSEL[2:0] |    |             | Reserved   | EXTTRIG   | EXTISEL     |            |            | ALIG        | Reserved   | ENDMA  | Reserved         |            |     |             | ENCAL      | CTU  | ON          |   |   |   |   |   |   |   |   |   |   |   |   |   |   |   |   |   |   |   |   |   |   |
|        | Reset Value  | 0        |            |    |    |            |            |    |            |    | 0           | 0          | 0        | 0           | 0            | 0  | 0           | 0          | 0         | 0           | 0          | 0          | 0           | 0          | 0      | 0                | 0          | 0   | 0           | 0          | 0    | 0           | 0 | 0 | 0 | 0 |   |   |   |   |   |   |   |   |   |   |   |   |   |   |   |   |   |   |
| 00Ch   | ADC_SAMPT1   | Reserved |            |    |    |            |            |    |            |    | SAMP17[2:0] |            |          | SAMP16[2:0] |              |    | SAMP15[2:0] |            |           | SAMP14[2:0] |            |            | SAMP13[2:0] |            |        | SAMP12[2:0]      |            |     | SAMP11[2:0] |            |      | SAMP10[2:0] |   |   |   |   |   |   |   |   |   |   |   |   |   |   |   |   |   |   |   |   |   |   |
|        | Reset Value  | 0        |            |    |    |            |            |    |            |    | 0           | 0          | 0        | 0           | 0            | 0  | 0           | 0          | 0         | 0           | 0          | 0          | 0           | 0          | 0      | 0                | 0          | 0   | 0           | 0          | 0    | 0           | 0 | 0 | 0 | 0 | 0 |   |   |   |   |   |   |   |   |   |   |   |   |   |   |   |   |   |
| 010h   | ADC_SAMPT2   | Reserved | SAMP9[2:0] |    |    | SAMP8[2:0] |            |    | SAMP7[2:0] |    |             | SAMP6[2:0] |          |             | SAMP5[2:0]   |    |             | SAMP4[2:0] |           |             | SAMP3[2:0] |            |             | SAMP2[2:0] |        |                  | SAMP1[2:0] |     |             | SAMP0[2:0] |      |             |   |   |   |   |   |   |   |   |   |   |   |   |   |   |   |   |   |   |   |   |   |   |
|        | Reset Value  | 0        | 0          | 0  | 0  | 0          | 0          | 0  | 0          | 0  | 0           | 0          | 0        | 0           | 0            | 0  | 0           | 0          | 0         | 0           | 0          | 0          | 0           | 0          | 0      | 0                | 0          | 0   | 0           | 0          | 0    | 0           |   |   |   |   |   |   |   |   |   |   |   |   |   |   |   |   |   |   |   |   |   |   |
| 014h   | ADC_JOFFSET1 | Reserved |            |    |    |            |            |    |            |    |             |            |          |             |              |    |             |            |           |             |            |            |             |            |        | OFFSETJCH2[11:0] |            |     |             |            |      |             |   |   |   |   |   |   |   |   |   |   |   |   |   |   |   |   |   |   |   |   |   |   |
|        | Reset Value  | 0        |            |    |    |            |            |    |            |    |             |            |          |             |              |    |             |            |           |             |            |            |             |            |        | 0                | 0          | 0   | 0           | 0          | 0    | 0           | 0 | 0 | 0 | 0 | 0 | 0 | 0 | 0 | 0 | 0 | 0 | 0 | 0 | 0 | 0 | 0 | 0 | 0 | 0 | 0 | 0 | 0 |
| 018h   | ADC_JOFFSET2 | Reserved |            |    |    |            |            |    |            |    |             |            |          |             |              |    |             |            |           |             |            |            |             |            |        | OFFSETJCH2[11:0] |            |     |             |            |      |             |   |   |   |   |   |   |   |   |   |   |   |   |   |   |   |   |   |   |   |   |   |   |
|        | Reset Value  | 0        |            |    |    |            |            |    |            |    |             |            |          |             |              |    |             |            |           |             |            |            |             |            |        | 0                | 0          | 0   | 0           | 0          | 0    | 0           | 0 | 0 | 0 | 0 | 0 | 0 | 0 | 0 | 0 | 0 | 0 | 0 | 0 | 0 | 0 | 0 | 0 | 0 | 0 | 0 | 0 | 0 |
| 01Ch   | ADC_JOFFSET3 | Reserved |            |    |    |            |            |    |            |    |             |            |          |             |              |    |             |            |           |             |            |            |             |            |        | OFFSETJCH3[11:0] |            |     |             |            |      |             |   |   |   |   |   |   |   |   |   |   |   |   |   |   |   |   |   |   |   |   |   |   |
|        | Reset Value  | 0        |            |    |    |            |            |    |            |    |             |            |          |             |              |    |             |            |           |             |            |            |             |            |        | 0                | 0          | 0   | 0           | 0          | 0    | 0           | 0 | 0 | 0 | 0 | 0 | 0 | 0 | 0 | 0 | 0 | 0 | 0 | 0 | 0 | 0 | 0 | 0 | 0 | 0 | 0 | 0 | 0 |
| 020h   | ADC_JOFFSET4 | Reserved |            |    |    |            |            |    |            |    |             |            |          |             |              |    |             |            |           |             |            |            |             |            |        | OFFSETJCH4[11:0] |            |     |             |            |      |             |   |   |   |   |   |   |   |   |   |   |   |   |   |   |   |   |   |   |   |   |   |   |
|        | Reset Value  | 0        |            |    |    |            |            |    |            |    |             |            |          |             |              |    |             |            |           |             |            |            |             |            |        | 0                | 0          | 0   | 0           | 0          | 0    | 0           | 0 | 0 | 0 | 0 | 0 | 0 | 0 | 0 | 0 | 0 | 0 | 0 | 0 | 0 | 0 | 0 | 0 | 0 | 0 | 0 | 0 | 0 |
| 024h   | ADC_WDGHIGH  | Reserved |            |    |    |            |            |    |            |    |             |            |          | HTH[11:0]   |              |    |             |            |           |             |            |            |             |            |        |                  |            |     |             |            |      |             |   |   |   |   |   |   |   |   |   |   |   |   |   |   |   |   |   |   |   |   |   |   |
|        | Reset Value  | 0        |            |    |    |            |            |    |            |    |             |            |          | 0           | 0            | 0  | 0           | 0          | 0         | 0           | 0          | 0          | 0           | 0          | 0      | 0                | 0          | 0   | 0           | 0          | 0    | 0           | 0 | 0 | 0 | 0 | 0 | 0 | 0 | 0 | 0 | 0 | 0 |   |   |   |   |   |   |   |   |   |   |   |
| 028h   | ADC_WDGLow   | Reserved |            |    |    |            |            |    |            |    |             |            |          | LTH[11:0]   |              |    |             |            |           |             |            |            |             |            |        |                  |            |     |             |            |      |             |   |   |   |   |   |   |   |   |   |   |   |   |   |   |   |   |   |   |   |   |   |   |
|        | Reset Value  | 0        |            |    |    |            |            |    |            |    |             |            |          | 0           | 0            | 0  | 0           | 0          | 0         | 0           | 0          | 0          | 0           | 0          | 0      | 0                | 0          | 0   | 0           | 0          | 0    | 0           | 0 | 0 | 0 | 0 | 0 | 0 | 0 | 0 | 0 | 0 | 0 | 0 |   |   |   |   |   |   |   |   |   |   |
| 02Ch   | ADC_RSEQ1    | Reserved |            |    |    |            |            |    |            |    | LEN[3:0]    |            |          | SEQ16[4:0]  |              |    |             | SEQ15[4:0] |           |             |            | SEQ14[4:0] |             |            |        | SEQ13[4:0]       |            |     |             |            |      |             |   |   |   |   |   |   |   |   |   |   |   |   |   |   |   |   |   |   |   |   |   |   |
|        | Reset Value  | 0        |            |    |    |            |            |    |            |    | 0           | 0          | 0        | 0           | 0            | 0  | 0           | 0          | 0         | 0           | 0          | 0          | 0           | 0          | 0      | 0                | 0          | 0   | 0           | 0          | 0    | 0           | 0 | 0 | 0 | 0 | 0 | 0 | 0 |   |   |   |   |   |   |   |   |   |   |   |   |   |   |   |
| 030h   | ADC_RSEQ2    | Reserved | SEQ12[4:0] |    |    |            | SEQ11[4:0] |    |            |    | SEQ10[4:0]  |            |          |             | SEQ9[4:0]    |    |             |            | SEQ8[4:0] |             |            |            | SEQ7[4:0]   |            |        |                  |            |     |             |            |      |             |   |   |   |   |   |   |   |   |   |   |   |   |   |   |   |   |   |   |   |   |   |   |
|        | Reset Value  | 0        | 0          | 0  | 0  | 0          | 0          | 0  | 0          | 0  | 0           | 0          | 0        | 0           | 0            | 0  | 0           | 0          | 0         | 0           | 0          | 0          | 0           | 0          | 0      | 0                | 0          | 0   | 0           | 0          | 0    | 0           | 0 | 0 |   |   |   |   |   |   |   |   |   |   |   |   |   |   |   |   |   |   |   |   |
| 034h   | ADC_RSEQ3    | Reserved | SEQ12[4:0] |    |    |            | SEQ11[4:0] |    |            |    | SEQ10[4:0]  |            |          |             | SEQ9[4:0]    |    |             |            | SEQ8[4:0] |             |            |            | SEQ7[4:0]   |            |        |                  |            |     |             |            |      |             |   |   |   |   |   |   |   |   |   |   |   |   |   |   |   |   |   |   |   |   |   |   |
|        | Reset Value  | 0        | 0          | 0  | 0  | 0          | 0          | 0  | 0          | 0  | 0           | 0          | 0        | 0           | 0            | 0  | 0           | 0          | 0         | 0           | 0          | 0          | 0           | 0          | 0      | 0                | 0          | 0   | 0           | 0          | 0    | 0           | 0 | 0 |   |   |   |   |   |   |   |   |   |   |   |   |   |   |   |   |   |   |   |   |

| Offset | Register    | 31       | 30 | 29 | 28 | 27 | 26 | 25 | 24 | 23 | 22 | 21 | 20            | 19         | 18        | 17       | 16       | 15         | 14  | 13    | 12     | 11         | 10       | 9       | 8         | 7          | 6 | 5             | 4 | 3 | 2 | 1 | 0 |   |   |   |   |   |   |   |   |   |   |
|--------|-------------|----------|----|----|----|----|----|----|----|----|----|----|---------------|------------|-----------|----------|----------|------------|-----|-------|--------|------------|----------|---------|-----------|------------|---|---------------|---|---|---|---|---|---|---|---|---|---|---|---|---|---|---|
| 038h   | ADC_JSEQ    | Reserved |    |    |    |    |    |    |    |    |    |    | JLEN[1:0]     | JSEQ4[4:0] |           |          |          | JSEQ3[4:0] |     |       |        | JSEQ2[4:0] |          |         |           | JSEQ1[4:0] |   |               |   |   |   |   |   |   |   |   |   |   |   |   |   |   |   |
|        | Reset Value |          |    |    |    |    |    |    |    |    |    |    | 0             | 0          | 0         | 0        | 0        | 0          | 0   | 0     | 0      | 0          | 0        | 0       | 0         | 0          | 0 | 0             | 0 | 0 | 0 | 0 | 0 | 0 | 0 | 0 | 0 | 0 | 0 | 0 | 0 | 0 | 0 |
| 03Ch   | ADC_JDAT1   | Reserved |    |    |    |    |    |    |    |    |    |    | JDAT1[15:0]   |            |           |          |          |            |     |       |        |            |          |         |           |            |   |               |   |   |   |   |   |   |   |   |   |   |   |   |   |   |   |
|        | Reset Value |          |    |    |    |    |    |    |    |    |    |    | 0             | 0          | 0         | 0        | 0        | 0          | 0   | 0     | 0      | 0          | 0        | 0       | 0         | 0          | 0 | 0             | 0 | 0 | 0 | 0 | 0 | 0 | 0 | 0 | 0 | 0 | 0 | 0 | 0 | 0 | 0 |
| 040h   | ADC_JDAT2   | Reserved |    |    |    |    |    |    |    |    |    |    | JDAT2[15:0]   |            |           |          |          |            |     |       |        |            |          |         |           |            |   |               |   |   |   |   |   |   |   |   |   |   |   |   |   |   |   |
|        | Reset Value |          |    |    |    |    |    |    |    |    |    |    | 0             | 0          | 0         | 0        | 0        | 0          | 0   | 0     | 0      | 0          | 0        | 0       | 0         | 0          | 0 | 0             | 0 | 0 | 0 | 0 | 0 | 0 | 0 | 0 | 0 | 0 | 0 | 0 | 0 | 0 | 0 |
| 044h   | ADC_JDAT3   | Reserved |    |    |    |    |    |    |    |    |    |    | JDAT3[15:0]   |            |           |          |          |            |     |       |        |            |          |         |           |            |   |               |   |   |   |   |   |   |   |   |   |   |   |   |   |   |   |
|        | Reset Value |          |    |    |    |    |    |    |    |    |    |    | 0             | 0          | 0         | 0        | 0        | 0          | 0   | 0     | 0      | 0          | 0        | 0       | 0         | 0          | 0 | 0             | 0 | 0 | 0 | 0 | 0 | 0 | 0 | 0 | 0 | 0 | 0 | 0 | 0 | 0 | 0 |
| 048h   | ADC_JDAT4   | Reserved |    |    |    |    |    |    |    |    |    |    | JDAT4[15:0]   |            |           |          |          |            |     |       |        |            |          |         |           |            |   |               |   |   |   |   |   |   |   |   |   |   |   |   |   |   |   |
|        | Reset Value |          |    |    |    |    |    |    |    |    |    |    | 0             | 0          | 0         | 0        | 0        | 0          | 0   | 0     | 0      | 0          | 0        | 0       | 0         | 0          | 0 | 0             | 0 | 0 | 0 | 0 | 0 | 0 | 0 | 0 | 0 | 0 | 0 | 0 | 0 | 0 | 0 |
| 04Ch   | ADC_DAT     | Reserved |    |    |    |    |    |    |    |    |    |    | DAT[15:0]     |            |           |          |          |            |     |       |        |            |          |         |           |            |   |               |   |   |   |   |   |   |   |   |   |   |   |   |   |   |   |
|        | Reset Value |          |    |    |    |    |    |    |    |    |    |    | 0             | 0          | 0         | 0        | 0        | 0          | 0   | 0     | 0      | 0          | 0        | 0       | 0         | 0          | 0 | 0             | 0 | 0 | 0 | 0 | 0 | 0 | 0 | 0 | 0 | 0 | 0 | 0 | 0 | 0 | 0 |
| 050h   | ADC_DIFSEL  | Reserved |    |    |    |    |    |    |    |    |    |    | DIFSEL[18:0]  |            |           |          |          |            |     |       |        |            |          |         |           |            |   | Reserved      |   |   |   |   |   |   |   |   |   |   |   |   |   |   |   |
|        | Reset Value |          |    |    |    |    |    |    |    |    |    |    | 0             | 0          | 0         | 0        | 0        | 0          | 0   | 0     | 0      | 0          | 0        | 0       | 0         | 0          | 0 | 0             | 0 | 0 | 0 | 0 | 0 | 0 | 0 | 0 | 0 | 0 | 0 | 0 | 0 | 0 | 0 |
| 054h   | ADC_CALFACT | Reserved |    |    |    |    |    |    |    |    |    |    | CALFACTD[6:0] |            |           |          | Reserved |            |     |       |        |            |          |         |           |            |   | CALFACTS[6:0] |   |   |   |   |   |   |   |   |   |   |   |   |   |   |   |
|        | Reset Value |          |    |    |    |    |    |    |    |    |    |    | 0             | 0          | 0         | 0        | 0        | 0          | 0   | 0     | 0      | 0          | 0        | 0       | 0         | 0          | 0 | 0             | 0 | 0 | 0 | 0 | 0 | 0 | 0 | 0 | 0 | 0 | 0 | 0 | 0 | 0 | 0 |
| 058h   | ADC_CTRL3   | Reserved |    |    |    |    |    |    |    |    |    |    | VBATMEN       | DPWMOD     | JENDCAIEN | ENDCAIEN | BPCAL    | PDRDY      | RDY | CKMOD | CALALD | CALDIF     | RES[1:0] |         |           |            |   |               |   |   |   |   |   |   |   |   |   |   |   |   |   |   |   |
|        | Reset Value |          |    |    |    |    |    |    |    |    |    |    | 0             | 0          | 0         | 0        | 0        | 0          | 0   | 0     | 0      | 0          | 0        | 0       | 0         | 0          | 0 | 0             | 0 | 0 | 0 |   |   |   |   |   |   |   |   |   |   |   |   |
| 05Ch   | ADC_SAMPT3  | Reserved |    |    |    |    |    |    |    |    |    |    | Reserved      |            |           |          |          |            |     |       |        |            |          | SAMPSEL | SAMP[2:0] |            |   |               |   |   |   |   |   |   |   |   |   |   |   |   |   |   |   |
|        | Reset Value |          |    |    |    |    |    |    |    |    |    |    |               |            |           |          |          |            |     |       |        |            |          | 0       | 0         | 0          | 0 |               |   |   |   |   |   |   |   |   |   |   |   |   |   |   |   |

### 9.12.2 ADC status register (ADC\_STS)

Address offset: 0x00

Reset value: 0x0000 0000

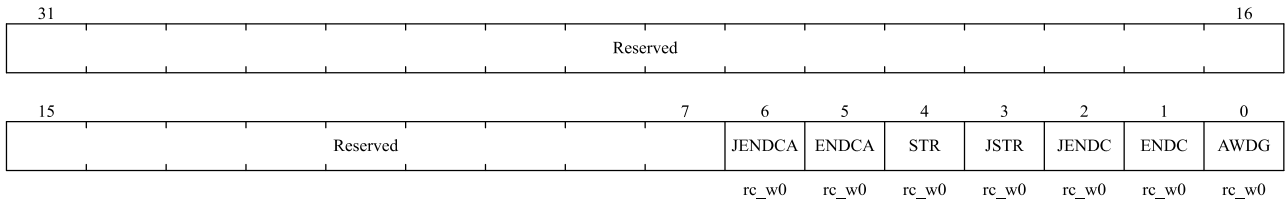

| Bit field | Name     | Description  |
|-----------|----------|--|
| 31:15     | Reserved | Reserved, the reset value must be maintained   |
| 6         | JENDCA   | Any injected channel end of conversion flag<br>This bit is set by hardware at the end of any injection channel conversion and cleared by software.<br>0: Conversion is not complete;<br>1: Conversion is complete.     |
| 5         | ENDCA    | Any channel end of conversion flag<br>This bit is set by hardware at the end of any channel (regular or injection) conversion and cleared by software.<br>0: Conversion is not complete;<br>1: Conversion is complete. |

| Bit field | Name  | Description  |
|-----------|-------|--|
| 4         | STR   | Regular channel start flag<br>This bit is set by hardware at the start of regular channel conversion and cleared by software.<br>0: Regular channel conversion has not started.<br>1: Regular channel conversion has started.                              |
| 3         | JSTR  | Injected channel start flag<br>This bit is set by hardware at the start of the injection channel conversion and cleared by software.<br>0: Injection sequence channel conversion has not started.<br>1: Injection sequence channel conversion has started. |
| 2         | JENDC | Injected channel end of conversion<br>This bit is set by hardware at the end of all injection sequence channel conversions and cleared by software<br>0: Conversion is not complete.<br>1: Conversion is complete.   |
| 1         | ENDC  | Conversion sequence channel end of conversion<br>This bit is set by hardware at the end of all regular( or injection) sequence channel conversion and cleared by software<br>0: Conversion is not complete.<br>1: Conversion is complete.                  |
| 0         | AWDG  | Analog watchdog flag<br>This bit is set by hardware and cleared by software when converted voltage values are outside the range defined by the ADC_LTR and ADC_HTR registers<br>0: Analog watchdog event not occurs;<br>1: Analog watchdog event occurs.   |

### 9.12.3 ADC control register 1 (ADC\_CTRL1)

Address offset: 0x04

Reset value: 0x0000 0000

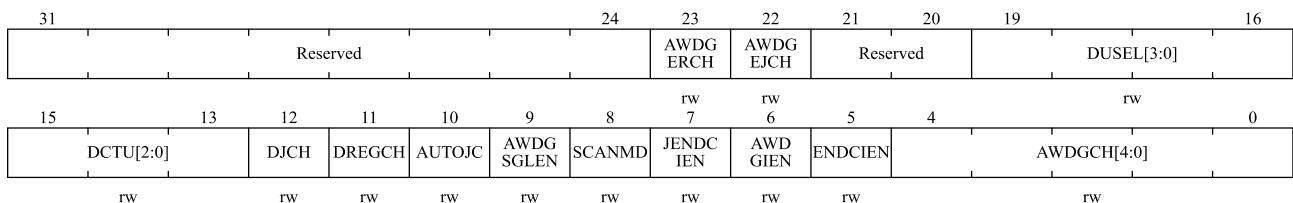

| Bit field | Name     | Description  |
|-----------|----------|--|
| 31:24     | Reserved | Reserved, the reset value must be maintained   |
| 23        | AWDGERCH | Analog watchdog enable on regular channels<br>This bit is set and cleared by the software.<br>0: Disables analog watchdog on regular channel.<br>1: Use analog watchdog on regular channels. |
| 22        | AWDGEJCH | Analog watchdog enable on injected channels<br>This bit is set and cleared by the software.  |

| Bit field | Name       | Description   |
|-----------|------------|---|
|           |            | 0: Disables analog watchdog on injection channel.<br>1: Use analog watchdog on the injection channel.   |
| 21:20     | Reserved   | Reserved, the reset value must be maintained  |
| 19:16     | DUSEL[3:0] | Dual mode selection<br>Software uses these bits to select modes of operation.<br>0000: independent mode;<br>0001: mixed synchronous regular mode + synchronous injection mode;<br>0010: mixed synchronous regular mode + rotation trigger mode;<br>0011: mixed synchronous injection mode + fast alternate mode;<br>0100: mixed synchronous injection mode + slow alternate mode;<br>0101: synchronous injection mode;<br>0110: synchronous regular mode;<br>0111: fast alternate mode;<br>1000: slow alternate mode;<br>1001: rotation trigger mode.<br>Note: These bits are reserved in ADC2 and ADC4. Changing the channel configuration in dual ADC mode will cause a restart condition. It is recommended to turn off the dual ADC mode before changing the configuration to avoid synchronization loss. |
| 15:13     | DCTU[2:0]  | Discontinuous mode channel count<br>The software uses these bits to define the number of channels for converting after receiving an external trigger in discontinuous mode<br>000: 1 channel<br>001: 2 channels<br>...<br>111: 8 channels   |
| 12        | DJCH       | Discontinuous mode on injected channels<br>This bit is set and cleared by the software. It is used to turn on or off discontinuous mode on injected channels.<br>0: Disable discontinuous mode on injection sequence channel<br>1: Enable discontinuous mode on injection sequence channel  |
| 11        | DREGCH     | Discontinuous mode is on regular channels.<br>This bit is set and cleared by the software. It is used to turn on or off discontinuous mode on regular channels.<br>0: Disable discontinuous mode on regular sequence channel<br>1: Enable discontinuous mode on regular sequence channel  |
| 10        | AUTOJC     | Automatic injected sequence conversion<br>This bit is set and cleared by the software to enable or disable automatic injection sequence channel conversion after regular sequence channel conversion is complete<br>0: Disable automatic injection channel conversion.<br>1: Enable automatic injection channel conversion.   |
| 9         | AWDGSLEN   | Enable the watchdog on a single channel in scan mode<br>This bit is set and cleared by software to enable or disable analog watchdog functions on channels specified by ADC_CTRL1.AWDGCH[4:0]   |

| Bit field | Name        | Description  |
|-----------|-------------|--|
|           |             | 0: Use watchdog on all channels.<br>1: Use watchdog on single channel.   |
| 8         | SCANMD      | Scan mode<br>This bit is set and cleared by the software to enable or disable scan mode. In scan mode, the conversion is made by ADC_RSEQx or the selected channel of the ADC_JSEQ register.<br>0: Disable scan mode.<br>1: Enable scan mode.<br><i>Note: If the ADC_CTRL1.ENDCIEN or ADC_CTRL1.JENDCIEN bits are set separately, ADC_STS.ENDC or ADC_STS.JENDC interrupts occur only after the last channel has been converted.</i> |
| 7         | JENDCIEN    | Interrupt enable for injected channels<br>This bit is set and cleared by the software to disallow or allow interrupts after all injection channel conversions have finished.<br>0: Disable JENDC interruption.<br>1: Enable JENDC interruption.  |
| 6         | AWDGIEN     | Analog watchdog interrupt enable<br>This bit is set and cleared by software to disallow or allow interrupt generated by analog watchdog. In scan mode, if the watchdog detects an out-of-range value, the scan is aborted only when that bit is set.<br>0: Disable analog watchdog interruption.<br>1: Enable analog watchdog interruption.  |
| 5         | ENDCIEN     | Interrupt enable for any channel<br>This bit is set and cleared by the software to disallow or allow interrupts to occur after the regular or injected channel conversion ends.<br>0: Disable ENDC interruption.<br>1: Enable ENDC interruption.   |
| 4:0       | AWDGCH[4:0] | Analog watchdog channel select bits<br>These bits are set and cleared by software to select input channels that analog watchdog protection.<br>00000: ADC analog input channel 0<br>00001: ADC analog input channel 1<br>...<br>01111: ADC analog input channel 15<br>10000: ADC analog input channel 16<br>10001: ADC analog input channel 17<br>10010: ADC analog input channel 18<br>Reserved all other values.                   |

### 9.12.4 ADC control register 2 (ADC\_CTRL2)

Address offset: 0x08

Reset value: 0x0000 0000

|              |  |              |  |      |  |          |  |       |  |          |              |              |              |              |  |     |          |    |  |          |  |   |  |
|--------------|--|--------------|--|------|--|----------|--|-------|--|----------|--------------|--------------|--------------|--------------|--|-----|----------|----|--|----------|--|---|--|
| 31           |  |              |  | 24   |  |          |  | 23    |  | 22       |              | 21           |              | 20           |  | 19  |          | 17 |  | 16       |  |   |  |
| Reserved     |  |              |  |      |  |          |  |       |  | TEMPEN   | SWSTR<br>RCH | SWSTR<br>JCH | EXT<br>RTRIG | EXTRSEL[2:0] |  |     | Reserved |    |  |          |  |   |  |
| 15           |  | 14           |  | 12   |  | 11       |  | 10    |  | 9        |              | 8            |              | 7            |  | 3   |          | 2  |  | 1        |  | 0 |  |
| EXT<br>JTRIG |  | EXTJSEL[2:0] |  | ALIG |  | Reserved |  | ENDMA |  | Reserved |              | Reserved     |              | ENCAL        |  | CTU |          | ON |  | Reserved |  |   |  |
| rw           |  | rw           |  | rw   |  | rw       |  | rw    |  | rw       |              | rw           |              | rw           |  | rw  |          | rw |  | rw       |  |   |  |

| Bit field | Name         | Description  |
|-----------|--------------|--|
| 31:24     | Reserved     | Reserved, the reset value must be maintained   |
| 23        | TEMPEN       | <p>Temperature sensor and V<sub>REFINT</sub> Enable</p> <p>This bit is set and cleared by the software to enable or disable the temperature sensor and V<sub>REFINT</sub> Channel.</p> <p>0: Disables the temperature sensor and V<sub>REFINT</sub>.</p> <p>1: Enable the temperature sensor and V<sub>REFINT</sub>.</p>   |
| 22        | SWSTRRCH     | <p>Start conversion of regular channels</p> <p>This bit is set by the software to start the conversion and cleared by the hardware as soon as the conversion begins. If SWSTRRCH is selected as the trigger event in the ADC_CTRL2.EXTRSEL[2:0] bit, which is used to initiate the conversion of a set of regular channels</p> <p>0: Reset state.</p> <p>1: Starts converting the regular channel.</p>   |
| 21        | SWSTRJCH     | <p>Start conversion of injected channels</p> <p>This bit is set by the software to initiate the conversion and can be cleared by the software or by the hardware as soon as the conversion begins. If SWSTRJCH is selected as the trigger event in the ADC_CTRL2.EXTJSEL[2:0] bit, which is used to initiate a conversion of a set of injected channels</p> <p>0: Reset state.</p> <p>1: Starts converting the injection channel.</p>  |
| 20        | EXTRTRIG     | <p>External trigger conversion mode for regular channels</p> <p>This bit is set and cleared by software to enable or disable external triggering events that can start regular sequence conversion.</p> <p>0: Start conversion without external events.</p> <p>1: Use an external event to start the conversion.</p>   |
| 19:17     | EXTRSEL[2:0] | <p>External event select for regular sequence</p> <p>These bits select external events to start the regular sequence conversion</p> <p>Trigger configuration for ADC1 and ADC2:</p> <p>000: TIM1_CC1 event;      100: TIM3_TRGO event;<br/>           001: TIM1_CC2 event;      101: TIM4_CC4 event;<br/>           010: TIM1_CC3 event;      110: EXTI line 11/TIM8_TRGO event;<br/>           011: TIM2_CC2 event;      111: SWSTRRCH.</p> <p>Trigger configuration for ADC3 and ADC4:</p> <p>000: TIM3_CC1 event;      100: TIM8_TRGO event;<br/>           001: TIM2_CC3 event;      101: TIM5_CC1 event;<br/>           010: TIM1_CC3 event;      110: EXTI line 10/TIM5_CC3 event;<br/>           011: TIM8_CC1 event;      111: SWSTRRCH.</p> |

| Bit field | Name         | Description  |
|-----------|--------------|--|
| 16        | Reserved     | Reserved, the reset value must be maintained   |
| 15        | EXTJTRIG     | External trigger conversion mode for injected channels<br>This bit is set and cleared by software to enable or disable external triggering events that can start injection sequence conversion.<br>0: Start conversion without external events.<br>1: Use an external event to start the conversion.   |
| 14:12     | EXTJSEL[2:0] | External event select for injected sequence<br>These bits select the External event used to trigger the injected sequence conversion.<br>Trigger configuration for ADC1 and ADC2:<br>000: TIM1_TRGO event;      100: TIM3_CC4 event;<br>001: TIM1_CC4 event;      101: TIM4_TRGO event;<br>010: TIM2_TRGO event;    110: EXTI line 15/TIM8_CC4 event;<br>011: TIM2_CC1 event;      111: SWSTRRCH.<br>Trigger configuration for ADC3 and ADC4:<br>000: TIM3_TRGO event;      100: TIM8_CC4 event;<br>001: TIM1_CC4 event;      101: TIM5_TRGO event;<br>010: TIM4_CC3 event;      110: EXTI line 14/TIM5_CC4 event;<br>011: TIM8_CC2 event;      111: SWSTRRCH. |
| 11        | ALIG         | Data alignment<br>This bit is set and cleared by the software. Refer to Table 9-3 and Table 9-4.<br>0: Right-aligned.<br>1: Left-aligned.  |
| 10:9      | Reserved     | Reserved, the reset value must be maintained   |
| 8         | ENDMA        | Direct memory access mode<br>This bit is set and cleared by the software. See the DMA Controller chapter for details.<br>0: Do not use DMA mode.<br>1: Use DMA mode.   |
| 7:3       | Reserved     | Reserved, the reset value must be maintained   |
| 2         | ENCAL        | A/D calibration<br>This bit is set by software to start calibration and cleared by hardware at the end of calibration.<br>0: Calibration completed;<br>1: Starts calibration.  |
| 1         | CTU          | Continuous conversion<br>This bit is set and cleared by the software. If this bit is set, the conversion continues until the bit is cleared.<br>0: Single conversion mode.<br>1: Continuous conversion mode.   |
| 0         | ON           | A/D converter ON/OFF<br>This bit is set and cleared by the software. When the bit is '0', writing '1' will wake the ADC from power-off mode.<br>When the bit is '1', writing '1' starts the conversion. The application should note that there is a delay $t_{STAB}$ between the time the converter is powered on and the time the conversion begins, see Figure 9-5.  |

| Bit field | Name | Description   |
|-----------|------|---|
|           |      | 0: Close ADC conversion/calibration and enter power-down mode.<br>1: Start ADC and start conversion.<br>Note: If there are other bits changed in this register along with ON, the conversion will not be triggered. This is to prevent the wrong conversion from being triggered. |

### 9.12.5 ADC sampling time register 1 (ADC\_SAMPT1)

Address offset: 0x0C

Reset value: 0x0000 0000

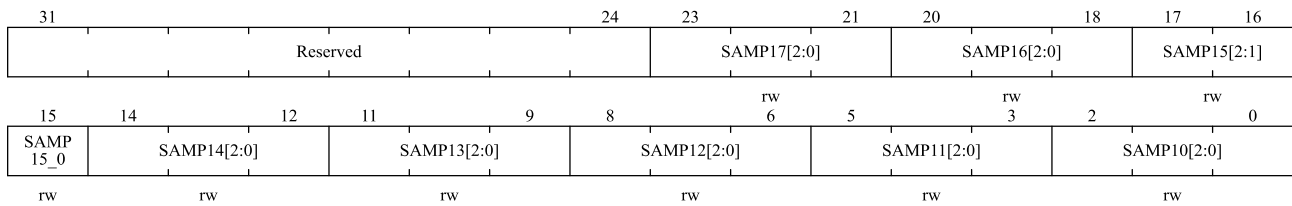

| Bit field | Name       | Description  |
|-----------|------------|--|
| 31:24     | Reserved   | Reserved, the reset value must be maintained   |
| 23:0      | SAMPx[2:0] | Channel x sample time selection<br>These bits are used to independently select the sampling time for each channel. The channel selection bit must remain constant during the sampling period.<br>ADC_SAMPT3.SAMPSEL = 0, the sampling time is set as follows:<br>000: 1.5 cycles                      100: 41.5 cycles<br>001: 7.5 cycles                      101: 55.5 cycles<br>010: 13.5 cycles                      110: 71.5 cycles<br>011: 28.5 cycles                      111: 239.5 cycles<br>ADC_SAMPT3.SAMPSEL = 1, the sampling time is set as follows:<br>000: 1.5 cycles                      100: 19.5 cycles<br>001: 2.5 cycles                      101: 61.5 cycles<br>010: 4.5 cycles                      110: 181.5 cycles<br>011: 7.5 cycles                      111: 601.5 cycles |

### 9.12.6 ADC sampling time register 2 (ADC\_SAMPT2)

Address offset: 0x10

Reset value: 0x0000 0000

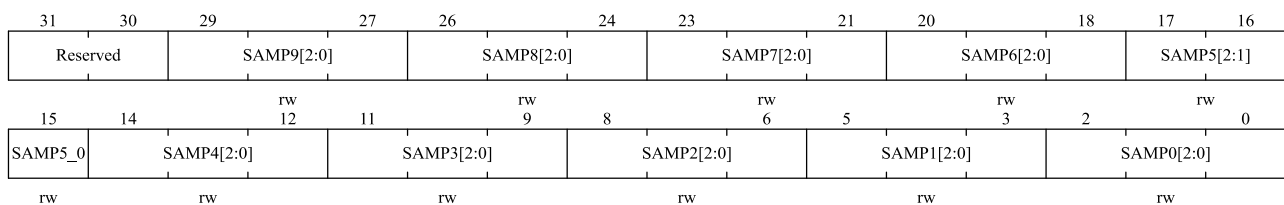

| Bit field | Name       | Description  |
|-----------|------------|--|
| 31:30     | Reserved   | Reserved, the reset value must be maintained   |
| 29:0      | SAMPx[2:0] | Channel x sample time selection<br>These bits are used to independently select the sampling time for each channel. The channel selection bit must remain constant during the sampling period.<br>ADC_SAMPT3.SAMPSEL = 0, the sampling time is set as follows:<br>000: 1.5 cycles            100: 41.5 cycles<br>001: 7.5 cycles            101: 55.5 cycles<br>010: 13.5 cycles           110: 71.5 cycles<br>011: 28.5 cycles           111: 239.5 cycles<br>ADC_SAMPT3.SAMPSEL = 1, the sampling time is set as follows:<br>000: 1.5 cycles            100: 19.5 cycles<br>001: 2.5 cycles            101: 61.5 cycles<br>010: 4.5 cycles            110: 181.5 cycles<br>011: 7.5 cycles            111: 601.5 cycles |

### 9.12.7 ADC injected channel data offset register x (ADC\_JOFFSETx) (x=1...4)

Address offset: 0x14-0x20

Reset value: 0x0000 0000

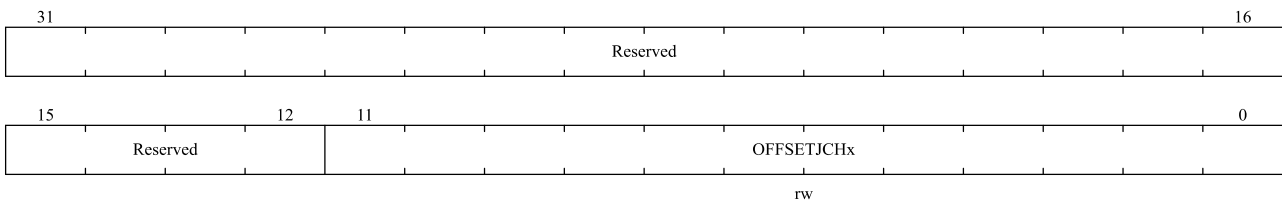

| Bit field | Name             | Description   |
|-----------|------------------|---|
| 31:12     | Reserved         | Reserved, the reset value must be maintained  |
| 11:0      | OFFSETJCHx[11:0] | Data offset for injected channel x<br>These bits define the values used to subtract from the original conversion data when the conversion is injected into the channel. The result of the conversion can be read in the ADC_JDATx register. |

### 9.12.8 ADC watchdog high threshold register (ADC\_WDGHIGH)

Address offset: 0x24

Reset value: 0x0000 0FFF

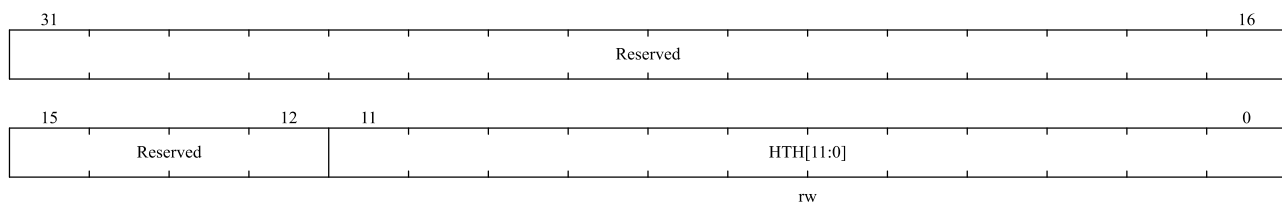

| Bit field | Name      | Description  |
|-----------|-----------|--|
| 31:12     | Reserved  | Reserved, the reset value must be maintained   |
| 11:0      | HTH[11:0] | Analog watchdog high threshold<br>These bits define the high thresholds for analog watchdog. |

### 9.12.9 ADC watchdog low threshold register (ADC\_WDGLow)

Address offset: 0x28

Reset value: 0x0000 0000

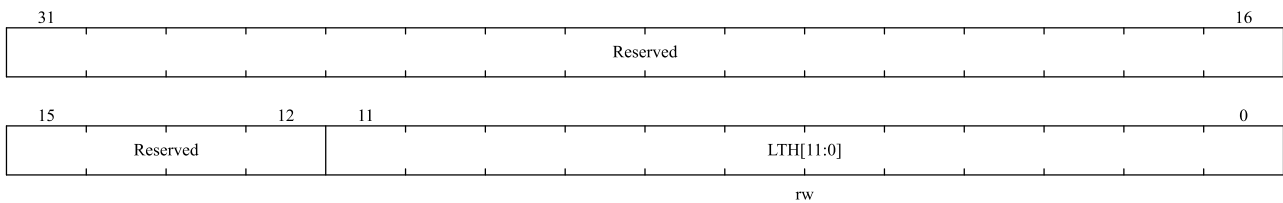

| Bit field | Name      | Description  |
|-----------|-----------|--|
| 31:12     | Reserved  | Reserved, the reset value must be maintained   |
| 11:0      | LTH[11:0] | Analog watchdog low threshold<br>These bits define the low thresholds for analog watchdog. |

### 9.12.10 ADC regular sequence register 1 (ADC\_RSEQ1)

Address offset: 0x2C

Reset value: 0x0000 0000

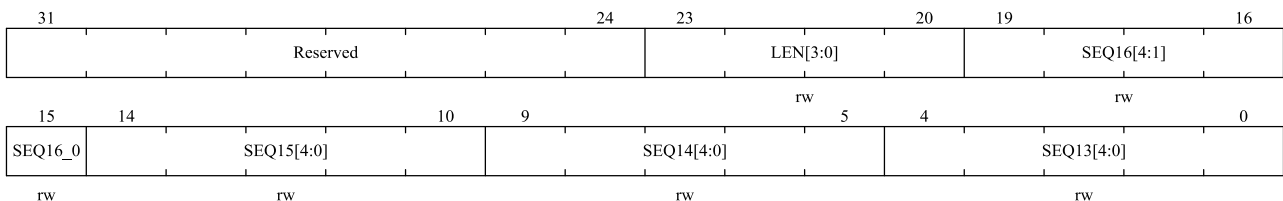

| Bit field | Name       | Description  |
|-----------|------------|--|
| 31:24     | Reserved   | Reserved, the reset value must be maintained   |
| 23:20     | LEN[3:0]   | Regular channel sequence length<br>These bits are software-defined as the number of channels in the regular sequence channel conversion.<br>0000: 1 conversion<br>0001: 2 conversions<br>...<br>1111: 16 conversions |
| 19:15     | SEQ16[4:0] | 16th conversion in regular sequence<br>These bits are software-defined as the number (0 to 18) of the 16th conversion channel in the conversion sequence.  |
| 14:10     | SEQ15[4:0] | 15th conversion in regular sequence  |
| 9:5       | SEQ14[4:0] | 14th conversion in regular sequence  |

| Bit field | Name       | Description                         |
|-----------|------------|-------------------------------------|
| 4:0       | SEQ13[4:0] | 13th conversion in regular sequence |

### 9.12.11 ADC regular sequence register 2 (ADC\_RSEQ2)

Address offset: 0x30

Reset value: 0x0000 0000

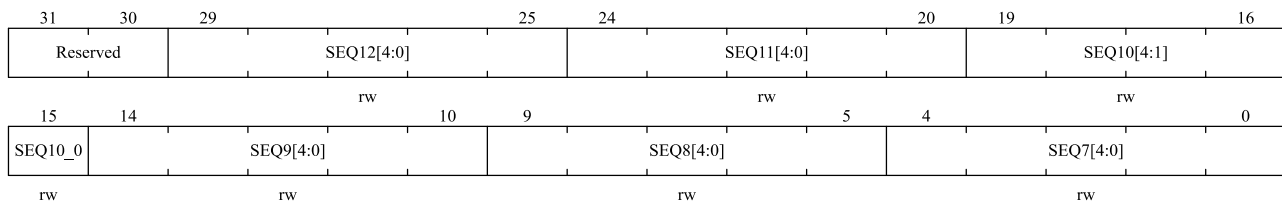

| Bit field | Name       | Description   |
|-----------|------------|---|
| 31:30     | Reserved   | Reserved, the reset value must be maintained  |
| 29:25     | SEQ12[4:0] | 12th conversion in regular sequence<br>These bits are software-defined as the number (0 to 18) of the 12th conversion channel in the conversion sequence. |
| 24:20     | SEQ11[4:0] | 11th conversion in regular sequence   |
| 19:15     | SEQ10[4:0] | 10th conversion in regular sequence   |
| 14:10     | SEQ9[4:0]  | 9th conversion in regular sequence  |
| 9:5       | SEQ8[4:0]  | 8th conversion in regular sequence  |
| 4:0       | SEQ7[4:0]  | 7th conversion in regular sequence  |

### 9.12.12 ADC regular sequence register 3 (ADC\_RSEQ3)

Address offset: 0x34

Reset value: 0x0000 0000

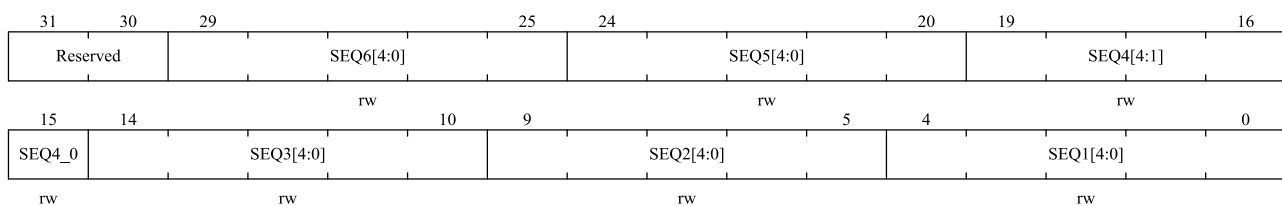

| Bit field | Name      | Description   |
|-----------|-----------|---|
| 31:30     | Reserved  | Reserved, the reset value must be maintained  |
| 29:25     | SEQ6[4:0] | 6th conversion in regular sequence<br>These bits are software-defined as the number (0 to 18) of the 6th transition channel in the conversion sequence. |
| 24:20     | SEQ5[4:0] | 5th conversion in regular sequence  |
| 19:15     | SEQ4[4:0] | 4th conversion in regular sequence  |
| 14:10     | SEQ3[4:0] | 3rd conversion in regular sequence  |
| 9:5       | SEQ2[4:0] | 2nd conversion in regular sequence  |

| Bit field | Name      | Description                        |
|-----------|-----------|------------------------------------|
| 4:0       | SEQ1[4:0] | 1st conversion in regular sequence |

### 9.12.13 ADC Injection sequence register (ADC\_JSEQ)

Address offset: 0x38

Reset value: 0x0000 0000

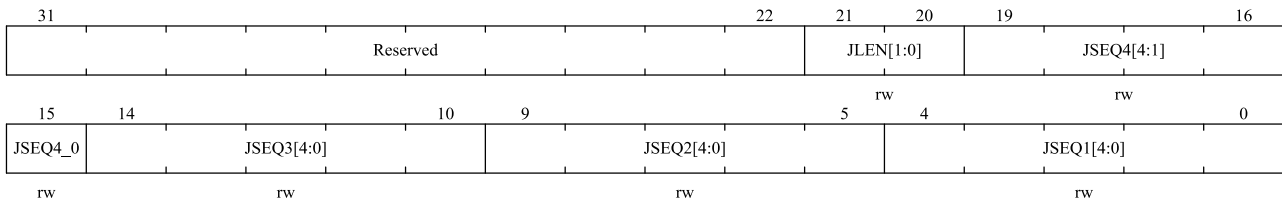

| Bit field | Name       | Description   |
|-----------|------------|---|
| 31:22     | Reserved   | Reserved, the reset value must be maintained  |
| 21:20     | JLEN[1:0]  | Injected sequence length<br>These bits are software-defined as the number of channels in the injected channel conversion sequence.<br>00: 1 conversion<br>01: 2 conversions<br>10: 3 conversions<br>11: 4 conversions   |
| 19:15     | JSEQ4[4:0] | This is the 4th conversion in the injected sequence.<br>These bits are software-defined as the number (0 to 18) of the fourth transition channel in the <i>conversion</i> sequence.<br><i>Note: Different from regular conversion sequences, if the length of ADC_JSEQ.JLEN[1:0] is less than 4, the sequence of conversion starts from (4-JLEN). For example, ADC_JSEQ[21:0] = 10 00011 00011 00111 00010 means that the scan conversion will be converted in the following channel order: 7, 3, 3 instead of 2, 7, 3.</i> |
| 14:10     | JSEQ3[4:0] | 3rd conversion in injected sequence   |
| 9:5       | JSEQ2[4:0] | 2nd conversion in injected sequence   |
| 4:0       | JSEQ1[4:0] | 1st conversion in injected sequence   |

### 9.12.14 ADC injection data register x (ADC\_JDATx) (x= 1...4)

Address offset: 0x3C - 0x48

Reset value: 0x0000 0000

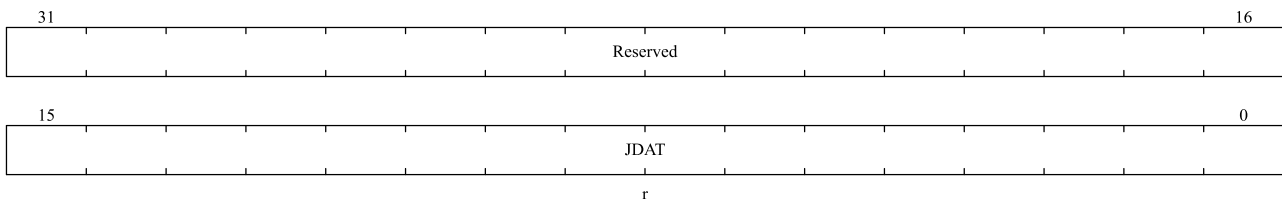

| Bit field | Name       | Description   |
|-----------|------------|---|
| 31:16     | Reserved   | Reserved, the reset value must be maintained  |
| 15:0      | JDAT[15:0] | Injected data for conversions<br>These bits are read-only and contain the conversion results of the injected channel. The data is left-aligned or right-aligned |

### 9.12.15 ADC regulars data register (ADC\_DAT)

Address offset: 0x4C

Reset value: 0x0000 0000

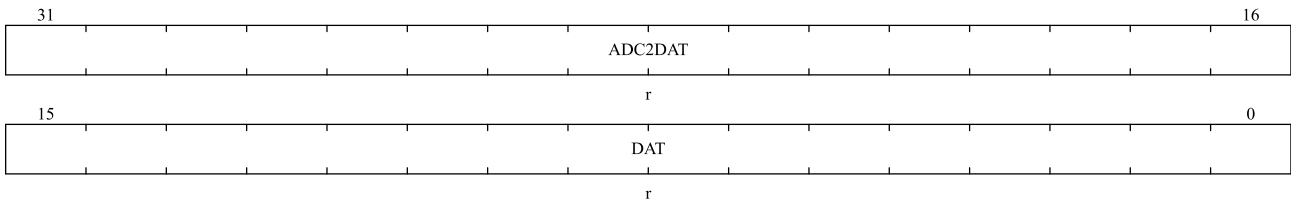

| Bit field | Name          | Description   |
|-----------|---------------|---|
| 31:16     | ADC2DAT[15:0] | Data converted by ADC2/ADC4 (ADC2 data, ADC4 data)<br>In ADC1 and ADC3: In dual ADC mode, these bits contain the regular channel data converted by ADC2 and ADC4.<br>In ADC2 and ADC4: These bits are not used. |
| 15:0      | DAT[15:0]     | Regular data for conversion<br>These bits are read-only and contain the conversion results of the regular channel. The data is left-aligned or right-aligned as shown in Table 9-3 and Table 9-4.               |

### 9.12.16 ADC differential mode selection register (ADC\_DIFSEL)

Address offset: 0x50

Reset value: 0x0000 0000

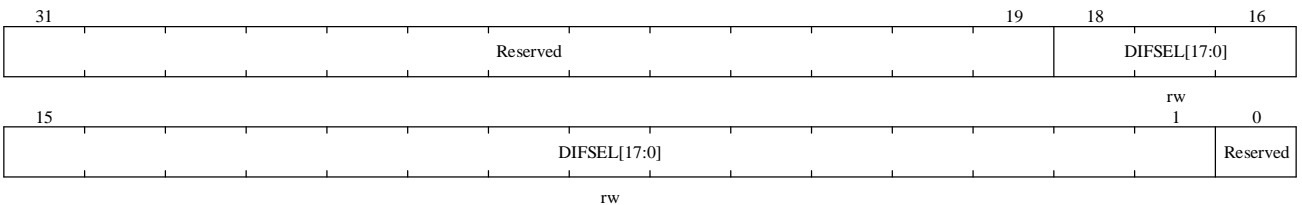

| Bit field | Name         | Description   |
|-----------|--------------|---|
| 31:19     | Reserved     | Reserved, the reset value must be maintained  |
| 18:1      | DIFSEL[17:0] | Differential mode for channels 18 to 1<br>DIFSEL[i] = 0: ADC channel input i+1 is configured in single-ended mode;<br>DIFSEL[i] = 1: ADC channel input i+1 is configured in differential mode |

| Bit field | Name     | Description                                  |
|-----------|----------|--|
| 0         | Reserved | Reserved, the reset value must be maintained |

### 9.12.17 ADC calibration factor (ADC\_CALFACT)

Address offset: 0x54

Reset value: 0x0000 0000

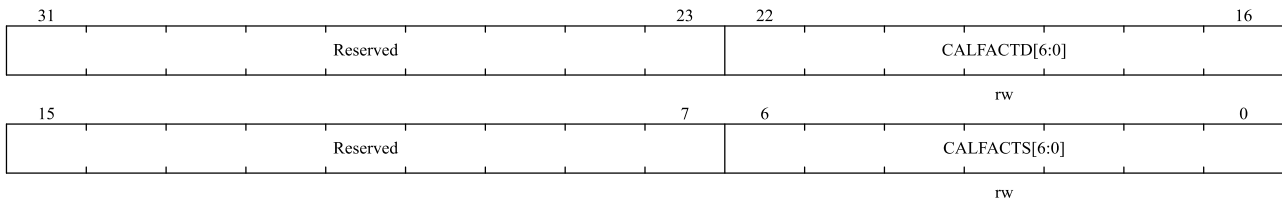

| Bit field | Name          | Description   |
|-----------|---------------|---|
| 31:23     | Reserved      | Reserved, the reset value must be maintained  |
| 22:16     | CALFACTD[6:0] | <p>Calibration factors in differential mode</p> <p>This bit can be written by hardware or software</p> <p>After the differential input calibration is complete, the hardware will update it according to the calibration coefficient.</p> <p>Software can write these bits with a new calibration factor. If the new calibration coefficient is different from the current coefficient stored in the analog ADC, the coefficient will be applied after a new differential calibration is initiated.</p> <p><i>Note: software allows write only when ADC_CTRL2.ON=1, ADC_STS.STR =0, ADC_STS.JSTR =0 (ADC does not process conversion or start conversion)</i></p> |
| 15:7      | Reserved      | Reserved, the reset value must be maintained  |
| 6:0       | CALFACTS[6:0] | <p>Calibration factors in Single-Ended mode</p> <p>This bit can be written by hardware or software</p> <p>After the single-end input calibration is completed, the hardware will update it according to the calibration coefficient.</p> <p>Software can write these bits with a new calibration factor. If the new calibration coefficient is different from the current coefficient stored in the analog ADC, the coefficient will be applied after a new single-ended calibration is initiated.</p> <p><i>Note: software allows write only when ADC_CTRL2.ON=1, ADC_STS.STR =0, ADC_STS.JSTR =0 (ADC does not process conversion or start conversion)</i></p>  |

### 9.12.18 ADC control register 3 (ADC\_CTRL3)

Address offset: 0x58

Reset value: 0x0000 0043

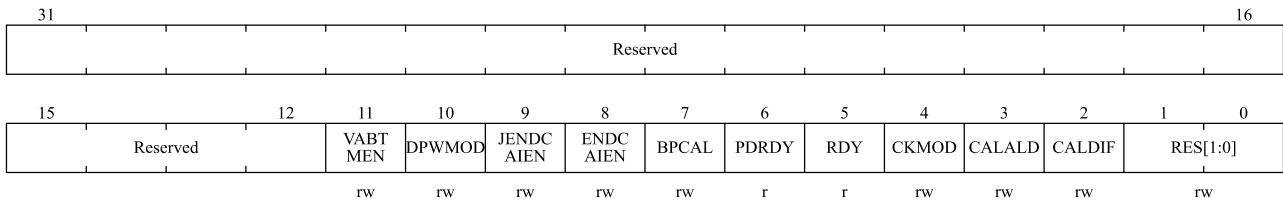

| Bit field | Name      | Description  |
|-----------|-----------|--|
| 31:12     | Reserved  | Reserved, the reset value must be maintained   |
| 11        | VBATMEN   | Vbat monitor enable<br>0: Disable<br>1: Enable   |
| 10        | DPWMOD    | Deep power mode<br>0: When the ADC is disabled, the ADC enters low power mode<br>1: When the ADC is disabled, the ADC enters deep sleep mode   |
| 9         | JENDCAIEN | Interrupt enable for any injected channels<br>This bit is set and cleared by the software to enable/disable the injection channel conversion end interrupt<br>0: ADC_STS.JENDCA interrupt is disabled<br>1: ADC_STS.JENDCA interrupt is enabled  |
| 8         | ENDCAIEN  | Interrupt enable for any regular channels<br>This bit is set and cleared by the software to enable/disable any channel conversion end interrupt<br>0: ADC_STS.ENDCA interrupt is disabled<br>1: ADC_STS.ENDCA interrupt is enabled   |
| 7         | BPCAL     | Bypass calibration<br>0: Disable<br>1: Enabled   |
| 6         | PDRDY     | ADC power down ready<br>0: Not ready<br>1: Get ready   |
| 5         | RDY       | ADC ready<br>0: Not ready<br>1: Get ready  |
| 4         | CKMOD     | Clock mode<br>0: Select AHB for synchronization clock<br>1: Select PLL for asynchronous clock  |
| 3         | CALALD    | Calibration auto load<br>0: Disables automatic loading<br>1: Enables automatic loading   |
| 2         | CALDIF    | Differential mode for calibration<br>This bit is set and cleared by software to configure the calibrated single-ended or differential input mode<br>0: Writing ADC_CTRL2.ENCAL bits will start calibration in single-ended input mode<br>1: Writing ADC_CTRL2.ENCAL bits will start calibration in differential input mode |

| Bit field | Name     | Description   |
|-----------|----------|---|
| 1:0       | RES[1:0] | Data resolution<br>This bit is set and cleared by the software to select the resolution of the conversion<br>00: 6-bits<br>01: 8-bits<br>10: 10-bits<br>11: 12-bits |

### 9.12.19 ADC sampling time register 3 (ADC\_SAMPT3)

Address offset: 0x5C

Reset value: 0x0000 0000

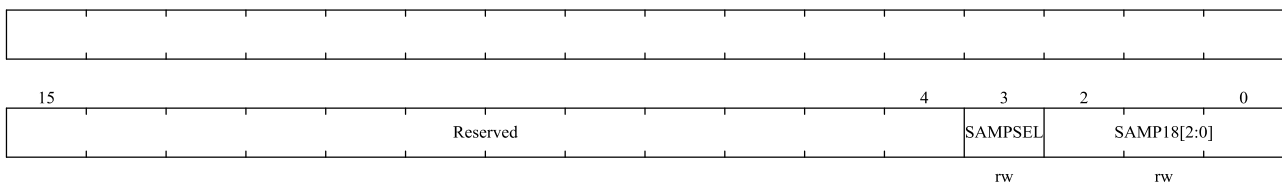

| Bit field | Name        | Description  |
|-----------|-------------|--|
| 31:4      | Reserved    | Reserved, the reset value must be maintained   |
| 3         | SAMPSEL     | Sample Time Selection<br>When SAMPSEL = 0, the value of SAMPx[2:0] is set as follows:<br>000: 1.5 cycles      100: 41.5 cycles<br>001: 7.5 cycles      101: 55.5 cycles<br>010: 13.5 cycles     110: 71.5 cycles<br>011: 28.5 cycles     111: 239.5 cycles<br>When SAMPSEL = 1, the value of SAMPx[2:0] is set as follows:<br>000: 1.5 cycles      100: 19.5 cycles<br>001: 2.5 cycles      101: 61.5 cycles<br>010: 4.5 cycles      110: 181.5 cycles<br>011: 7.5 cycles      111: 601.5 cycles |
| 2:0       | SAMP18[2:0] | Channel Sample Time<br>The channel sampling time definition is consistent with ADC_SAMPT2  |

## 10 Digital to analog conversion (DAC)

### 10.1 Introduction

DAC is a digital/analog converter, mainly digital input, voltage output. DAC data can be 8-bit or 12-bit and supports DMA functionality. When the DAC is configured in 12-bit mode, the DAC data can be right-aligned or left-aligned. When the DAC is configured in 8-bit mode, the DAC data can be right-aligned. The DAC output channel has 2, with independent converter. Both channels can be configured to convert independently or to convert simultaneously and update the output simultaneously.  $V_{REF+}$  is used as the DAC reference voltage through the pin input to make the DAC conversion data more accurate.

### 10.2 Main features

- Two independent DAC converter, corresponding to two output channel.
- Monotonous output.
- Support 8-bit or 12-bit output, data in 12-bit mode right-aligned and left-aligned two modes.
- Synchronous update.
- DMA support.
- Noise wave, triangular waveform generation.
- Input reference voltage  $V_{REF+}$ .
- External event triggers the conversion.
- Two DAC channels are synchronized or converted independently.

DAC block diagram and pins are shown below.

Figure 10-1 Block diagram of a DAC channel

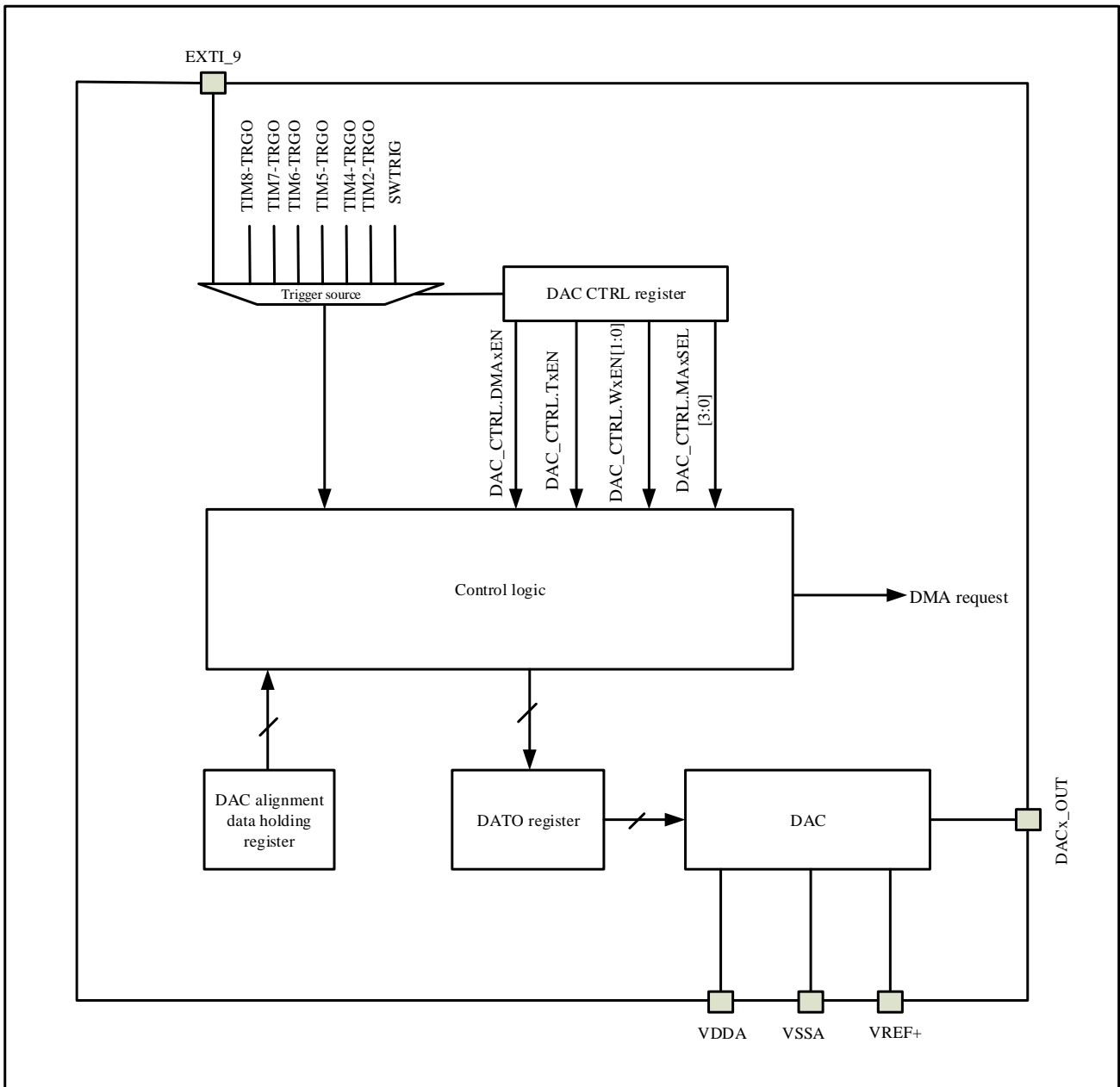

Table 10-1 DAC pins

| Name              | Description  | Type                                     |
|-------------------|--|--|
| V <sub>REF+</sub> | The positive reference voltage used by the DAC, $2.4V \leq V_{REF+} \leq V_{DDA}$ (3.3V) | Input, positive analog reference voltage |
| V <sub>DDA</sub>  | Analog power   | Input, analog power                      |
| V <sub>SSA</sub>  | Analog power ground  | Input, analog power ground               |
| DACx_OUT          | DAC analog output  | Analog output signal                     |

*Note: When the DACx is enabled, PA4 or PA5 needs to be configured as analog input mode. PA4 or PA5 will automatically connect to the output of the DACx.*

## 10.3 DAC function description and operation description

### 10.3.1 DAC enable

Powering on the DAC can be done by configuring DAC\_CTRL. CHxEN = 1. It takes some time for t<sub>WAKEUP</sub> to open the DAC.

### 10.3.2 DAC output buffer.

By configuring DAC\_CTRL.BxEN to disable or enable the output buffer of DAC, if the output buffer is enable, the output impedance is reduced, the driving ability is enhanced, and the external load can be driven without the external operational amplifier.

### 10.3.3 DAC data format

According to the data alignment configuration, the corresponding registers of the data configuration are as follows:

When the DAC outputs independently, there are 3 cases:

- When the configuration data is written to the DAC\_DR12CHx register, the data is written to DAC\_DR12CHx [11:0], and the 12-bit data is right-aligned. (Actually stored in the register DACCHxD [11:0] bits, DACCHxD is the internal data storage register)
- When the configuration data is written to the DAC\_DL12CHx register, the data is written to DAC\_DL12CHx [15:4], and the 12-bit data is left-aligned. (Actually stored in the register DACCHxD [11:0] bits, DACCHxD is the internal data storage register)
- When the configuration data is written to the DAC\_DR8CHx register, the data is written to DAC\_DR8CHx [7:0], and the 8-bit data is right-aligned. (Actually stored in the register DACCHxD[11:4] bits, DACCHxD is the internal data storage register)

Figure 10-2 Data format when DAC independent output

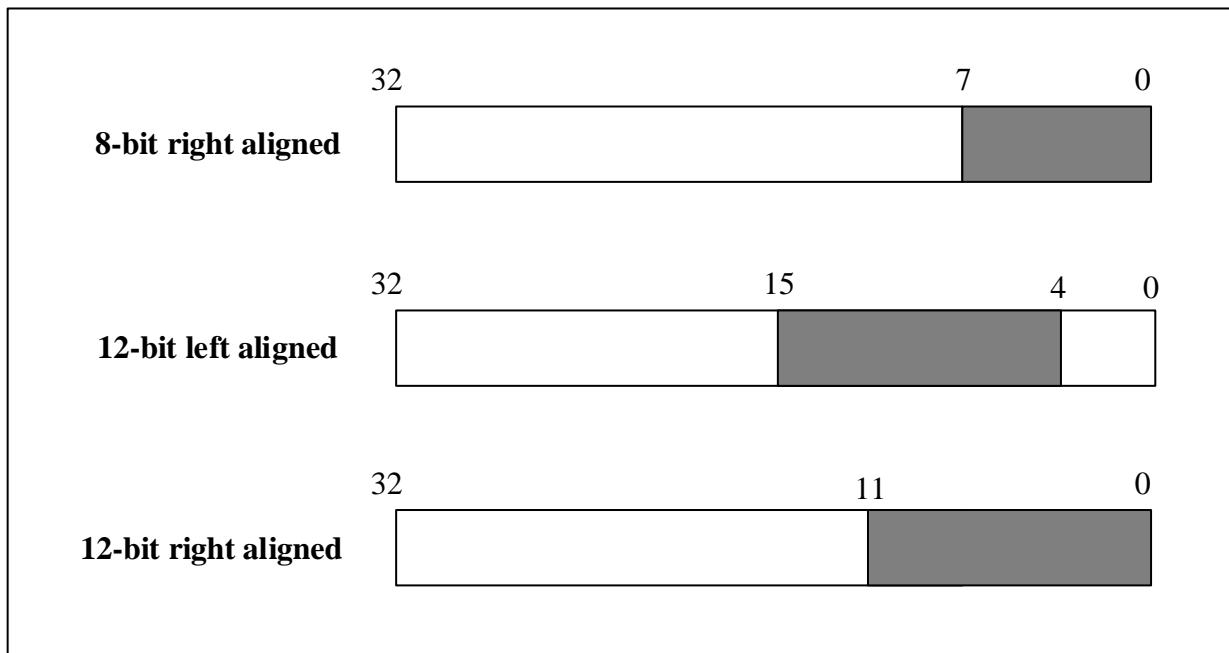

When the DAC outputs synchronously, there are 3 cases:

- When the configuration data is written to the DAC\_DR12DCH register, the DAC1 data is written to DAC\_DR12DCH [11:0] (Actually stored in the register DACCH1D [11:0] bits, DACCH1D is the internal data storage register), the DAC2 data is written to DAC\_DR12DCH [27:16] (Actually stored in the register DACCH2D [11:0] bits, DACCH2D is the internal data storage register).
- When the configuration data is written to the DAC\_DR12DCH register, the DAC1 data is written to DAC\_DR12DCH [15:4] (Actually stored in the register DACCH1D [11:0] bits, DACCH1D is the internal data storage register), the DAC2 data is written to DAC\_DR12DCH [31:20] (Actually stored in the register DACCH2D [11:0] bits, DACCH2D is the internal data storage register).
- When the configuration data is written to the DAC\_DR8DCH register, the DAC1 data is written to DAC\_DR8DCH [7:0] (Actually stored in the register DACCH1D [11:4] bits, DACCH1D is the internal data storage register), the DAC2 data is written to DAC\_DR8DCH [15:8] (Actually stored in the register DACCH2D [11:4] bits, DACCH2D is the internal data storage register).

Figure 10-3 Data format for DAC sync output

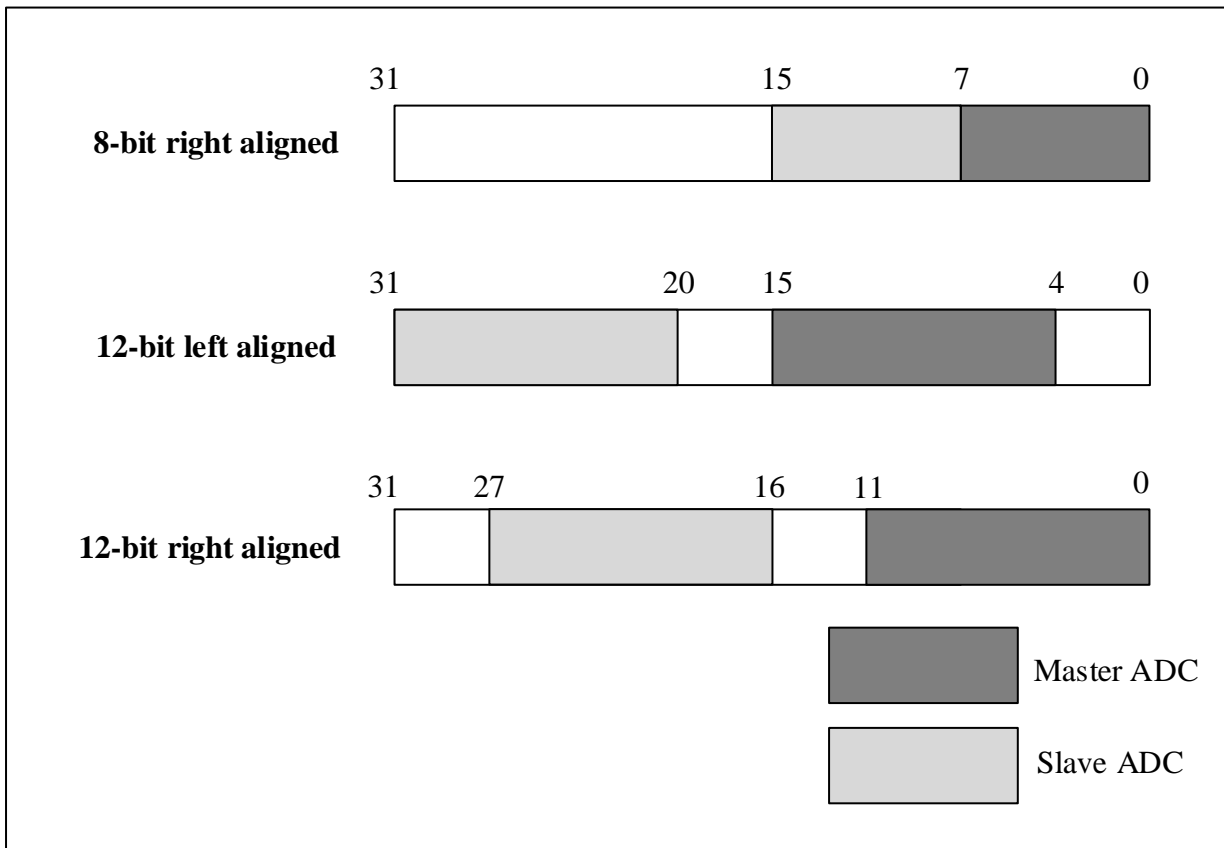

### 10.3.4 DAC trigger

Configure DAC\_CTRL. TEN = 1 enables the external trigger of the DAC, and DAC\_CTRL.TxSEL [2:0] is configured to select an external triggering event as the external triggering source for the DAC.

Table 10-2 DAC external trigger

| Trigger source              | Type                                   | TSEL[2:0] |
|-----------------------------|--|-----------|
| Timer 6 TRGO events         | Internal signal from the on-chip timer | 000       |
| Timer 8 TRGO events         |  | 001       |
| Timer 7 TRGO events         |  | 010       |
| Timer 5 TRGO events         |  | 011       |
| Timer 2 TRGO events         |  | 100       |
| Timer 4 TRGO events         |  | 101       |
| EXTI line 9                 | External pins                          | 110       |
| SWTRIG (Software Triggered) | Software control bit                   | 111       |

When the DAC is triggered by timer output or the rising edge of EXTI line 9, when triggered, the data in the aligned data hold register will be transferred to the DAC\_DATOx register. This data transfer process takes 3 APB1 clock cycles.

DAC\_SOTTR.TRxEN = 1 can enable the DAC software trigger. When the DAC is triggered by the software, the

data of the aligned data hold register will be transmitted to the DAC\_DATOx register.

*Note:*

1. Do not change the `DAC_CTRL.TxSEL[2:0]` bit when the DAC is enabled.
2. It takes 1 APB1 clock cycle for the data of the aligned data holding register to be transferred to the `DAC_DATOx` register when triggered by software..

### 10.3.5 DAC conversion

If DAC trigger is on, the data in the DAC alignment data hold register will be transferred to the `DAC_DATOx` register after three APB1 cycles according to the selected trigger event when the hardware trigger occurs. When the software trigger occurs, the data in the DAC alignment data hold register is transferred to the `DAC_DATOx` register after one APB1 cycle..

After the DAC transfers data to the `DAC_DATOx` register from its data hold register, the output is valid for the time  $t_{SETTLING}$ , which is related to the supply voltage and the analog output load.

Figure 10-4 Time diagram of transitions with trigger disabled

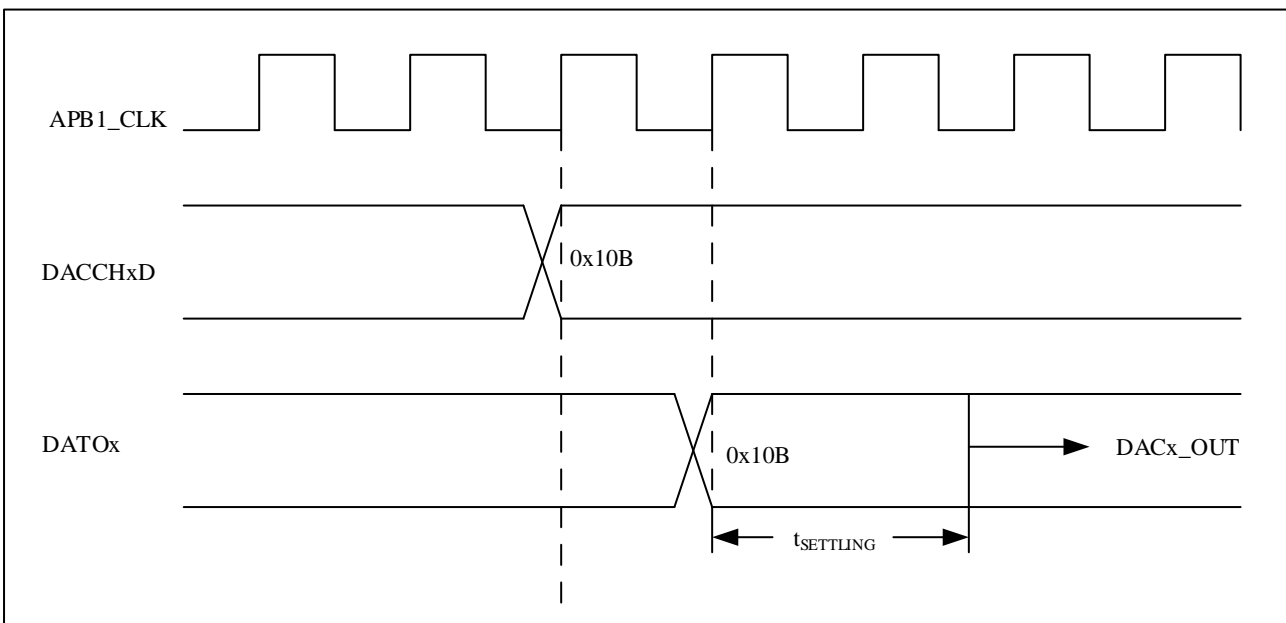

### 10.3.6 DAC output voltage

The digital input is converted to analog voltage output by a DAC module in a linear relationship ranging from 0 to  $V_{REF+}$ . The output voltage of DAC is calculated as follows:

$$\text{DAC output} = V_{REF} \times (\text{DATO} / 4095).$$

### 10.3.7 DMA requests

`DAC_CTRL.DMAxEN = 1` is configured to enable DMA function. 2 DMA channels correspond to two DACs respectively. When an external trigger occurs (not a software trigger), a DMA request is generated and the data aligned

with the data hold register is then transferred to the DAC\_DAT0x register.

When the dual DAC mode is turned on, only one DMA is needed to transmit data, so only one DAC is used to turn on the DMA function, and two DMA requests will appear when two DACs are turned on.

*Note: DMA requests for DAC have no accumulative function, and when the second external trigger occurs before the response to the first external trigger, the second DMA request cannot be processed and there is no error reporting mechanism.*

### 10.3.8 The noise

DAC can generate noise, by configuring DAC\_CTRL.WxEN[1:0] to "01" to turn on the noise function, by configuring DAC\_CTRL.MAxSEL[3:0] to select which bits of the linear feedback shift register (LFSR) are masked, the value of LFSR is added to the value of the DAC alignment data holding register and written to the DAC\_DAT0x register (overflow bits are discarded). The initial value of LFSR is 0xAAA, and the value of LFSR is updated after 3 APB1 cycles after the trigger event occurs.

Figure 10-5 LFSR algorithm for DAC

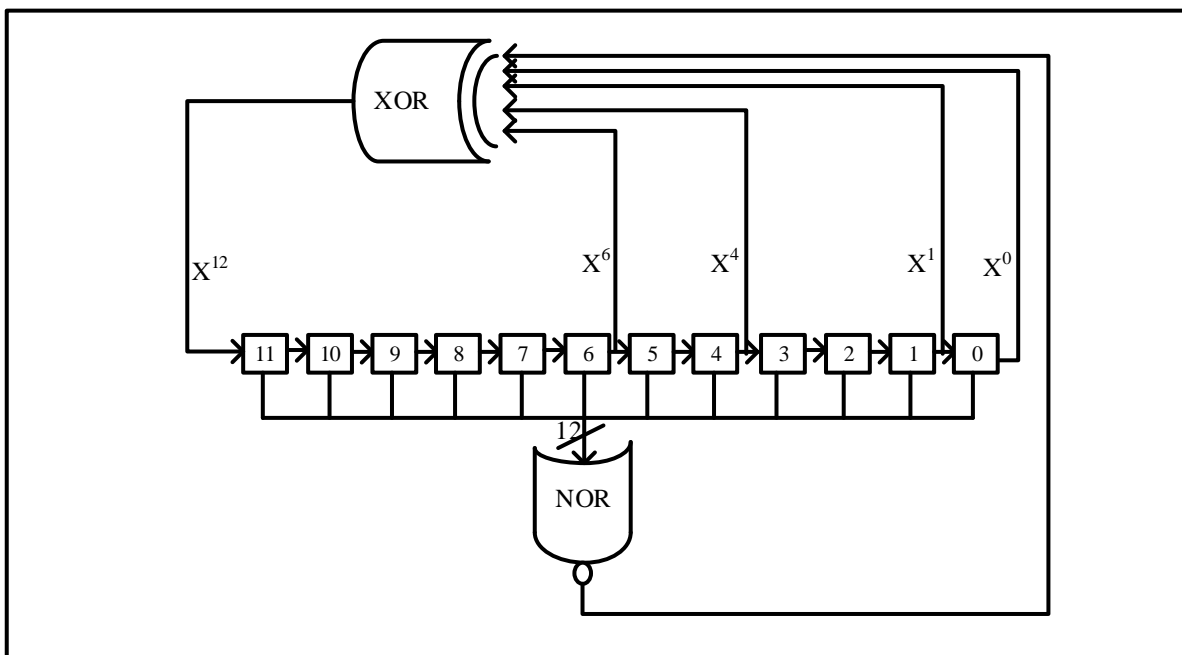
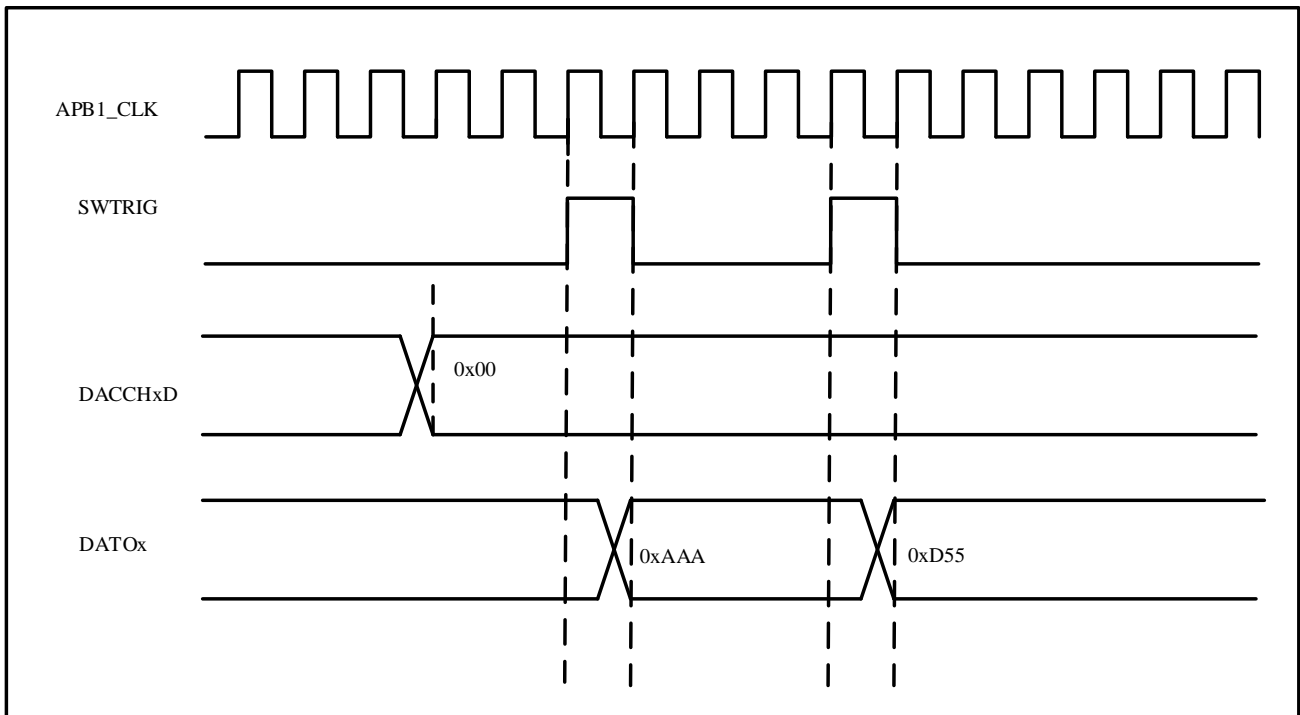

Figure 10-6 DAC conversion with LFSR waveform generation (enable software trigger)



Note: The DAC is configured to trigger to generate noise.

### 10.3.9 Triangular wave generation

The DAC can generate a triangle wave. The triangle wave function can be turned on by configuring DAC\_CTRL.WxEN[1:0] as "10", and the amplitude of the triangle wave can be selected by configuring DAC\_CTRL.MAxSEL[3:0]. The value of the internal triangle wave counter is added to the value of the DAC alignment data holding register and written to the DAC\_DATOx register (overflow bits are discarded). The value of the triangular wave counter is updated 3 APB1 cycles after the trigger event occurs, the triangular wave counter will accumulate to the maximum amplitude value set, and then decrement to 0, and so on.

Figure 10-7 Triangle wave generation of DAC

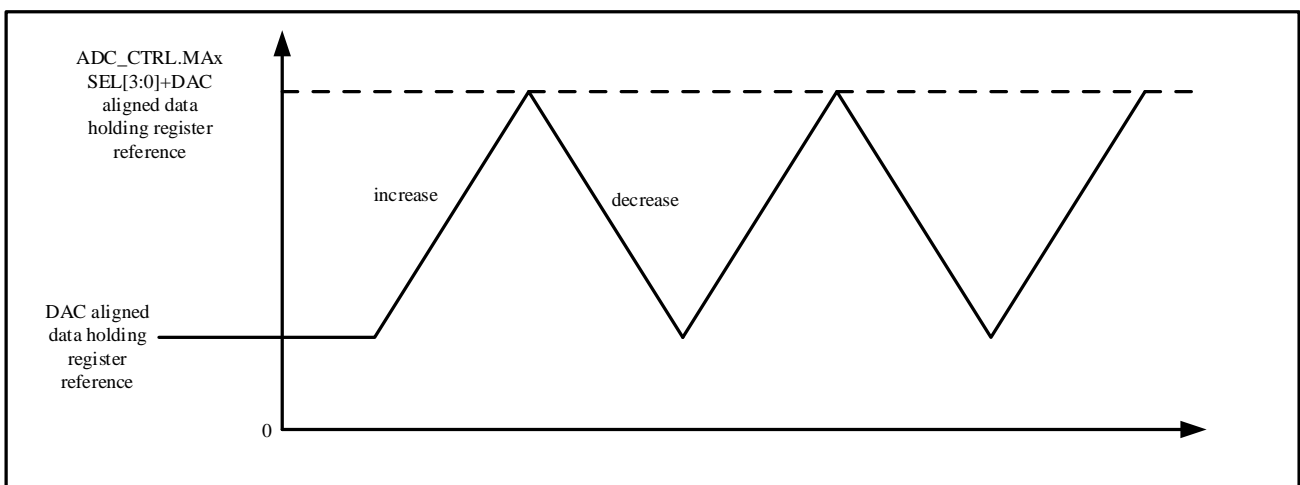
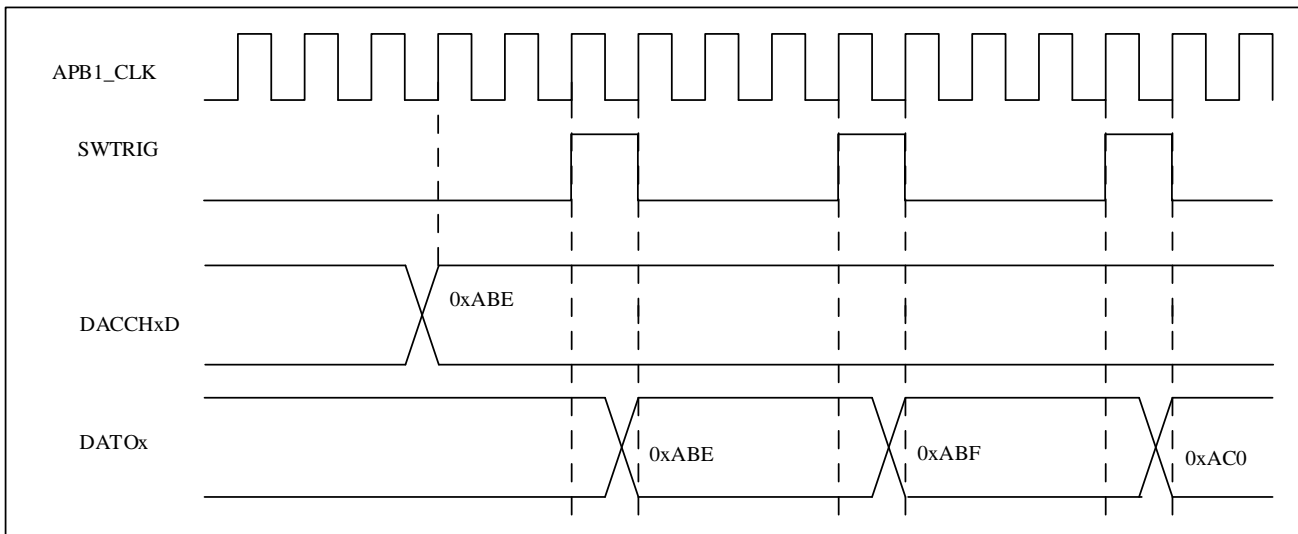

Figure 10-8 DAC conversion with trigonometry generation (enable software trigger)



Note: 1. Only when the DAC is configured to trigger can the triangle wave be generated

2. `DAC_CTRL.MAxSEL[3:0]` cannot be set after DAC is enabled.

## 10.4 DAC dual-channel conversion

The two channels of the DAC can work independently or at the same time. In this mode, a total of 3 registers, `DAC_DR12DCH`, `DAC_DL12DCH` and `DAC_DR8DCH`, can be used, which can efficiently utilize the bus bandwidth, and each register can operate on 2 DACs at the same time.

The dual DAC channels turn on the conversion at the same time. There are 11 modes in total. When only one DAC is used for conversion, the other DAC can still operate independently. For details, please refer to the following chapter description.

### 10.4.1 Independent trigger without waveform generator

The configuration process is as follows:

- Configure `DAC_CTRL.T1EN` and `DAC_CTRL.T2EN` to enable trigger enable of DAC1 and DAC2.
- Configure `DAC_CTRL.T1SEL[2:0]` and `DAC_CTRL.T2SEL[2:0]` as different values to select different trigger sources.
- Put the data to be converted into the corresponding alignment data holding register.

When the DAC1 trigger event occurs, the value of the aligned data holding register will be transferred to the register `DAC_DATO1` after a delay of 3 APB1 clock cycles. When the DAC2 trigger event occurs, the value of the aligned data holding register will be transferred to the register `DAC_DATO2` after a delay of 3 APB1 clock cycles.

### 10.4.2 Independent triggers producing the same noise

The configuration process is as follows:

- Configure `DAC_CTRL.T1EN` and `DAC_CTRL.T2EN` to enable trigger enable of DAC1 and DAC2.

- Configure DAC\_CTRL.T1SEL[2:0] and DAC\_CTRL.T2SEL[2:0] as different values to select different trigger sources.
- Configure DAC\_CTRL.W1EN[1:0] and DAC\_CTRL.W2EN[1:0] as “01” to select noise generation enable.
- Configure DAC\_CTRL.MA1SEL[3:0] and DAC\_CTRL.MA2SEL[3:0] to the same value to get the same LFSR register mask bit.
- Put the data to be converted into the corresponding alignment data holding register.

When the DAC1 trigger event occurs, the counter value of the LFSR register 1 is added to the value of the corresponding data holding register. The added value is transferred to the register DAC\_DATO1 after a delay of 3 APB1 clock cycles, and the counter value of the LFSR register 1 will be updated at this time. When the DAC2 trigger event occurs, the counter value of the LFSR register 2 is added to the value of the corresponding data holding register. The added value is transferred to the register DAC\_DATO2 after a delay of 3 APB1 clock cycles, and the counter value of the LFSR register 2 will be updated at this time.

### 10.4.3 Independent triggers that generate different noises

The configuration process is as follows:

- Configure DAC\_CTRL.T1EN and DAC\_CTRL.T2EN to enable trigger enable of DAC1 and DAC2.
- Configure DAC\_CTRL.T1SEL[2:0] and DAC\_CTRL.T2SEL[2:0] as different values to select different trigger sources.
- Configure DAC\_CTRL.W1EN[1:0] and DAC\_CTRL.W2EN[1:0] as “01” to select noise generation enable.
- Configure DAC\_CTRL.MA1SEL[3:0] and DAC\_CTRL.MA2SEL[3:0] as different values to get different LFSR register mask bits.
- Put the data to be converted into the corresponding alignment data holding register.

When the DAC1 trigger event occurs, the counter value of the LFSR register 1 is added to the value of the corresponding data holding register. The added value is transferred to the register DAC\_DATO1 after a delay of 3 APB1 clock cycles, and the counter value of the LFSR register 1 will be updated at this time. When the DAC2 trigger event occurs, the counter value of the LFSR register 2 is added to the value of the corresponding data holding register. The added value is transferred to the register DAC\_DATO2 after a delay of 3 APB1 clock cycles, and the counter value of the LFSR register 2 will be updated at this time.

### 10.4.4 Independent triggers that generate the same triangle wave

The configuration process is as follows:

- Configure DAC\_CTRL.T1EN and DAC\_CTRL.T2EN to enable trigger enable of DAC1 and DAC2.
- Configure DAC\_CTRL.T1SEL[2:0] and DAC\_CTRL.T2SEL[2:0] as different values to select different trigger sources.
- Configure DAC\_CTRL.W1EN[1:0] and DAC\_CTRL.W2EN[1:0] as “1x” to select the triangle wave generation enable.
- Configure DAC\_CTRL.MA1SEL[3:0] and DAC\_CTRL.MA2SEL[3:0] to the same value to get the same

triangle wave amplitude.

- Put the data to be converted into the corresponding alignment data holding register.

When the DAC1 trigger event occurs, the triangular wave amplitude value of DAC1 is added to the corresponding data holding register value. The added value is transferred to the register DAC\_DATO1 after a delay of 3 APB1 clock cycles, and the counter value of the triangular wave of DAC1 will be updated at this time. When the DAC2 trigger event occurs, the triangular wave amplitude value of DAC2 is added to the value of the corresponding data holding register. The added value is transferred to the register DAC\_DATO2 after a delay of 3 APB1 clock cycles, and the counter value of the triangular wave of DAC2 will be updated at this time.

### 10.4.5 Independent trigger to generate different triangle waves

The configuration process is as follows:

- Configure DAC\_CTRL.T1EN and DAC\_CTRL.T2EN to enable trigger enable of DAC1 and DAC2.
- Configure DAC\_CTRL.T1SEL[2:0] and DAC\_CTRL.T2SEL[2:0] as different values to select different trigger sources.
- Configure DAC\_CTRL.W1EN[1:0] and DAC\_CTRL.W2EN[1:0] as “1x” to select the triangle wave generation enable.
- Configure DAC\_CTRL.MA1SEL[3:0] and DAC\_CTRL.MA2SEL[3:0] as different values to get different triangle wave amplitudes.
- Put the data to be converted into the corresponding alignment data holding register.

When the DAC1 trigger event occurs, the triangular wave amplitude value of DAC1 is added to the corresponding data holding register value. The added value is transferred to the register DAC\_DATO1 after a delay of 3 APB1 clock cycles, and the counter value of the triangular wave of DAC1 will be updated at this time. When the DAC2 trigger event occurs, the triangular wave amplitude value of DAC2 is added to the value of the corresponding data holding register. The added value is transferred to the register DAC\_DATO2 after a delay of 3 APB1 clock cycles, and the counter value of the triangular wave of DAC2 will be updated at this time.

### 10.4.6 Simultaneous software startup

The configuration process is as follows:

- Configure DAC\_CTRL.T1EN and DAC\_CTRL.T2EN to enable trigger enable of DAC1 and DAC2.
- Configure DAC\_CTRL.TR1EN and DAC\_CTRL.TR2EN to select software trigger.
- Put the data to be converted into the corresponding alignment data holding register.

The value of the aligned data holding register of DAC1 will be transferred into register DAC\_DATO1 after a delay of 1 APB1 clock cycle.

The value of the aligned data holding register of DAC2 will be transferred to register DAC\_DATO2 after a delay of 1 APB1 clock cycle.

### 10.4.7 Synchronous trigger without waveform generator

The configuration process is as follows:

- Configure DAC\_CTRL.T1EN and DAC\_CTRL.T2EN to enable trigger enable of DAC1 and DAC2.
- Configure DAC\_CTRL.T1SEL[2:0] and DAC\_CTRL.T2SEL[2:0] to be the same value to select the same trigger source.
- Put the data to be converted into the corresponding alignment data holding register.

When a trigger event occurs, the value of the alignment data holding register of DAC1 will be transferred to the register DAC\_DATO1 after a delay of 3 APB1 clock cycles; the value of the alignment data holding register of DAC2 will be transferred to the register DAC\_DATO2 after a delay of 3 APB1 clock cycles.

### 10.4.8 Synchronous triggers that generate the same noise

The configuration process is as follows:

- Configure DAC\_CTRL.T1EN and DAC\_CTRL.T2EN to enable trigger enable of DAC1 and DAC2.
- Configure DAC\_CTRL.T1SEL[2:0] and DAC\_CTRL.T2SEL[2:0] to be the same value to select the same trigger source.
- Configure DAC\_CTRL.W1EN[1:0] and DAC\_CTRL.W2EN[1:0] as “01” to select noise generation enable.
- Configure DAC\_CTRL.MA1SEL[3:0] and DAC\_CTRL.MA2SEL[3:0] to the same value to get the same LFSR register mask bit.
- Put the data to be converted into the corresponding alignment data holding register.

When a trigger event occurs, the counter value of LFSR register 1 is added to the value of the corresponding data holding register. The added value is transferred to register DAC\_DATO1 after a delay of 3 APB1 clock cycles, and the counter value of LFSR register 1 will be updated at this time; LFSR The counter value of register 2 is added to the value of the corresponding data holding register. The added value is transferred to register DAC\_DATO2 after a delay of 3 APB1 clock cycles, and the counter value of LFSR register 2 will be updated at this time.

### 10.4.9 Synchronous triggers that generate different noises

The configuration process is as follows:

- Configure DAC\_CTRL.T1EN and DAC\_CTRL.T2EN to enable trigger enable of DAC1 and DAC2.
- Configure DAC\_CTRL.T1SEL[2:0] and DAC\_CTRL.T2SEL[2:0] as same values to select same trigger sources.
- Configure DAC\_CTRL.W1EN[1:0] and DAC\_CTRL.W2EN[1:0] as “01” to select noise generation enable.
- Configure DAC\_CTRL.MA1SEL[3:0] and DAC\_CTRL.MA2SEL[3:0] to the different value to get the different LFSR register mask bit.
- Put the data to be converted into the corresponding alignment data holding register.

When a trigger event occurs, the counter value of LFSR register 1 is added to the value of the corresponding data holding register. The added value is transferred to register DAC\_DATO1 after a delay of 3 APB1 clock cycles, and

the counter value of LFSR register 1 will be updated at this time; LFSR The counter value of register 2 is added to the value of the corresponding data holding register. The added value is transferred to register DAC\_DATO2 after a delay of 3 APB1 clock cycles, and the counter value of LFSR register 2 will be updated at this time.

#### 10.4.10 Synchronous trigger to generate the same triangle wave

The configuration process is as follows:

- Configure DAC\_CTRL.T1EN and DAC\_CTRL.T2EN to enable trigger enable of DAC1 and DAC2.
- Configure DAC\_CTRL.T1SEL[2:0] and DAC\_CTRL.T2SEL[2:0] to be the same value to select the same trigger source.
- Configure DAC\_CTRL.W1EN[1:0] and DAC\_CTRL.W2EN[1:0] as “1x” to select the triangle wave generation enable.
- Configure DAC\_CTRL.MA1SEL[3:0] and DAC\_CTRL.MA2SEL[3:0] to the same value to get the same triangle wave amplitude.
- Put the data to be converted into the corresponding alignment data holding register.

When a trigger event occurs, the triangular wave amplitude value of DAC1 is added to the value of the corresponding data holding register. The added value is transferred to the register DAC\_DATO1 after a delay of 3 APB1 clock cycles, and the counter value of the triangular wave of DAC1 will be updated at this time; The triangular wave amplitude is added to the value of the corresponding data holding register. The added value is transferred to the register DAC\_DATO2 after a delay of 3 APB1 clock cycles, and the counter value of the triangular wave of DAC2 will be updated at this time.

#### 10.4.11 Synchronous trigger to generate different triangle waves

The configuration process is as follows:

- Configure DAC\_CTRL.T1EN and DAC\_CTRL.T2EN to enable trigger enable of DAC1 and DAC2.
- Configure DAC\_CTRL.T1SEL[2:0] and DAC\_CTRL.T2SEL[2:0] to be the same value to select the same trigger source.
- Configure DAC\_CTRL.W1EN[1:0] and DAC\_CTRL.W2EN[1:0] as “1x” to select the triangle wave generation enable.
- Configure DAC\_CTRL.MA1SEL[3:0] and DAC\_CTRL.MA2SEL[3:0] as different values to get different triangle wave amplitudes.
- Put the data to be converted into the corresponding alignment data holding register.

When a trigger event occurs, the triangular wave amplitude value of DAC1 is added to the value of the corresponding data holding register. The added value is transferred to the register DAC\_DATO1 after a delay of 3 APB1 clock cycles, and the counter value of the triangular wave of DAC1 will be updated at this time; The triangular wave amplitude is added to the value of the corresponding data holding register. The added value is transferred to the register DAC\_DATO2 after a delay of 3 APB1 clock cycles, and the counter value of the triangular wave of DAC2 will be updated at this time.

## 10.5 DAC register

### 10.5.1 DAC registers overview

Table 10-3 DAC registers overview

| Offset | Register    | 31            | 30 | 29 | 28 | 27 | 26 | 25 | 24            | 23          | 22 | 21 | 20             | 19 | 18         | 17           | 16   | 15            | 14    | 13       | 12 | 11 | 10           | 9        | 8 | 7 | 6             | 5           | 4        | 3 | 2         | 1 | 0          |  |      |      |       |
|--------|-------------|---------------|----|----|----|----|----|----|---------------|-------------|----|----|----------------|----|------------|--------------|------|---------------|-------|----------|----|----|--------------|----------|---|---|---------------|-------------|----------|---|-----------|---|------------|--|------|------|-------|
| 000h   | DAC_CTRL    | Reserved      |    |    |    |    |    |    | DMA2EN        | MA2SEL[3:0] |    |    | W2EN[1:0]      |    | T2SEL[2:0] |              | T2EN | B2EN          | CH2EN | Reserved |    |    |              |          |   |   | DMA1EN        | MA1SEL[3:0] |          |   | W1EN[1:0] |   | T1SEL[2:0] |  | T1EN | B1EN | CH1EN |
|        | Reset Value | 0             |    |    |    |    |    |    | 0             | 0           |    |    | 0              |    | 0          |              | 0    | 0             | 0     | 0        |    |    |              |          |   |   | 0             | 0           |          |   | 0         |   | 0          |  | 0    | 0    | 0     |
| 004h   | DAC_SOTTR   | Reserved      |    |    |    |    |    |    |               |             |    |    |                |    |            |              |      |               |       |          |    |    |              |          |   |   |               | TR2EN       | TR1EN    |   |           |   |            |  |      |      |       |
|        | Reset Value | 0             |    |    |    |    |    |    |               |             |    |    |                |    |            |              |      |               |       |          |    |    |              |          |   |   |               | 0           | 0        |   |           |   |            |  |      |      |       |
| 008h   | DAC_DR12CH1 | Reserved      |    |    |    |    |    |    |               |             |    |    | DACCH1D[11:0]  |    |            |              |      |               |       |          |    |    |              |          |   |   |               |             |          |   |           |   |            |  |      |      |       |
|        | Reset Value | 0             |    |    |    |    |    |    |               |             |    |    | 0              |    |            |              |      |               |       |          |    |    |              |          |   |   |               |             |          |   |           |   |            |  |      |      |       |
| 00Ch   | DAC_DL12CH1 | Reserved      |    |    |    |    |    |    |               |             |    |    | DACCH1D[11:0]  |    |            |              |      |               |       |          |    |    |              | Reserved |   |   |               |             |          |   |           |   |            |  |      |      |       |
|        | Reset Value | 0             |    |    |    |    |    |    |               |             |    |    | 0              |    |            |              |      |               |       |          |    |    |              | 0        |   |   |               |             |          |   |           |   |            |  |      |      |       |
| 010h   | DAC_DR8CH1  | Reserved      |    |    |    |    |    |    |               |             |    |    |                |    |            | DACCH1D[7:0] |      |               |       |          |    |    |              |          |   |   |               |             |          |   |           |   |            |  |      |      |       |
|        | Reset Value | 0             |    |    |    |    |    |    |               |             |    |    |                |    |            | 0            |      |               |       |          |    |    |              |          |   |   |               |             |          |   |           |   |            |  |      |      |       |
| 014h   | DAC_DR12CH2 | Reserved      |    |    |    |    |    |    |               |             |    |    | DACCH2D[11:0]  |    |            |              |      |               |       |          |    |    |              |          |   |   |               |             |          |   |           |   |            |  |      |      |       |
|        | Reset Value | 0             |    |    |    |    |    |    |               |             |    |    | 0              |    |            |              |      |               |       |          |    |    |              |          |   |   |               |             |          |   |           |   |            |  |      |      |       |
| 018h   | DAC_DL12CH2 | Reserved      |    |    |    |    |    |    |               |             |    |    | DACCH2D[11:0]  |    |            |              |      |               |       |          |    |    |              | Reserved |   |   |               |             |          |   |           |   |            |  |      |      |       |
|        | Reset Value | 0             |    |    |    |    |    |    |               |             |    |    | 0              |    |            |              |      |               |       |          |    |    |              | 0        |   |   |               |             |          |   |           |   |            |  |      |      |       |
| 01Ch   | DAC_DR8CH2  | Reserved      |    |    |    |    |    |    |               |             |    |    |                |    |            | DACCH2D[7:0] |      |               |       |          |    |    |              |          |   |   |               |             |          |   |           |   |            |  |      |      |       |
|        | Reset Value | 0             |    |    |    |    |    |    |               |             |    |    |                |    |            | 0            |      |               |       |          |    |    |              |          |   |   |               |             |          |   |           |   |            |  |      |      |       |
| 020h   | DAC_DR12DCH | Reserved      |    |    |    |    |    |    | DACCH2D[11:0] |             |    |    |                |    |            |              |      |               |       | Reserved |    |    |              |          |   |   | DACCH1D[11:0] |             |          |   |           |   |            |  |      |      |       |
|        | Reset Value | 0             |    |    |    |    |    |    | 0             |             |    |    |                |    |            |              |      |               |       | 0        |    |    |              |          |   |   | 0             |             |          |   |           |   |            |  |      |      |       |
| 024h   | DAC_DL12DCH | DACCH2D[11:0] |    |    |    |    |    |    |               |             |    |    | Reserved       |    |            |              |      | DACCH1D[11:0] |       |          |    |    |              |          |   |   |               |             | Reserved |   |           |   |            |  |      |      |       |
|        | Reset Value | 0             |    |    |    |    |    |    |               |             |    |    | 0              |    |            |              |      | 0             |       |          |    |    |              |          |   |   |               |             | 0        |   |           |   |            |  |      |      |       |
| 028h   | DAC_DR8DCH  | Reserved      |    |    |    |    |    |    |               |             |    |    |                |    |            | DACCH2D[7:0] |      |               |       |          |    |    | DACCH1D[7:0] |          |   |   |               |             |          |   |           |   |            |  |      |      |       |
|        | Reset Value | 0             |    |    |    |    |    |    |               |             |    |    |                |    |            | 0            |      |               |       |          |    |    | 0            |          |   |   |               |             |          |   |           |   |            |  |      |      |       |
| 02Ch   | DAC_DATO1   | Reserved      |    |    |    |    |    |    |               |             |    |    | DACCH1DO[11:0] |    |            |              |      |               |       |          |    |    |              |          |   |   |               |             |          |   |           |   |            |  |      |      |       |
|        | Reset Value | 0             |    |    |    |    |    |    |               |             |    |    | 0              |    |            |              |      |               |       |          |    |    |              |          |   |   |               |             |          |   |           |   |            |  |      |      |       |
| 030h   | DAC_DATO2   | Reserved      |    |    |    |    |    |    |               |             |    |    | DACCH2DO[11:0] |    |            |              |      |               |       |          |    |    |              |          |   |   |               |             |          |   |           |   |            |  |      |      |       |
|        | Reset Value | 0             |    |    |    |    |    |    |               |             |    |    | 0              |    |            |              |      |               |       |          |    |    |              |          |   |   |               |             |          |   |           |   |            |  |      |      |       |

### 10.5.2 DAC control register (DAC\_CTRL)

Offset address: 0x00

Reset value: 0x0000 0000

|          |    |        |             |    |    |           |    |            |    |      |      |       |
|----------|----|--------|-------------|----|----|-----------|----|------------|----|------|------|-------|
| 31       | 29 | 28     | 27          | 24 | 23 | 22        | 21 | 19         | 18 | 17   | 16   |       |
| Reserved |    | DMA2EN | MA2SEL[3:0] |    |    | W2EN[1:0] |    | T2SEL[2:0] |    | T2EN | B2EN | CH2EN |
| 15       | 13 | 12     | 11          | 8  | 7  | 6         | 5  | 3          | 2  | 1    | 0    |       |
| Reserved |    | DMA1EN | MA1SEL[3:0] |    |    | W1EN[1:0] |    | T1SEL[2:0] |    | T1EN | B1EN | CH1EN |
|          |    | rw     | rw          |    |    | rw        |    | rw         |    | rw   | rw   | rw    |

| Bit field | Name     | Description                                   |
|-----------|----------|---|
| 31:29     | Reserved | Reserved, the reset value must be maintained. |
| 28        | DMA2EN   | The DMA function of the DAC2 is enabled       |

| Bit field | Name        | Description   |
|-----------|-------------|---|
|           |             | The bit is set to 1 and cleared by the software.<br>0: Disable DMA for the DAC2;<br>1: Enable the DMA function of the DAC2.   |
| 27:24     | MA2SEL[3:0] | DAC2 shield/amplitude selector.<br>These bits are configured by software to set the LFSR shielding bits for the noise function and the amplitude of the triangular wave.<br>0000: unmasked LFSR bit 0 / triangular amplitude equals 1;<br>0001: unmasked LFSR bit [1:0] / triangular amplitude equal 3;<br>0010: unmasked LFSR bit [2:0] / triangular amplitude equals 7;<br>0011: unmasked LFSR bit [3:0] / triangular amplitude equals 15;<br>0100: unmasked LFSR bit [4:0] / triangular amplitude equals 31;<br>0101: unmasked LFSR bit [5:0] / triangular amplitude equals 63;<br>0110: unmasked LFSR bit [6:0] / triangular amplitude equals 127;<br>0111: unmasked LFSR bit [7:0] / triangular amplitude equals 255;<br>1000: unmasked LFSR bit [8:0] / triangular amplitude equals 511;<br>1001: unmasked LFSR bit [9:0] / triangular amplitude equals 1023;<br>1010: unmasked LFSR bit [10:0] / triangular amplitude equals 2047;<br>≥1011: unmasked LFSR bit [11:0] / triangular amplitude equal 4095. |
| 23:22     | W2EN[1:0]   | DAC2 noise/triangle wave function selection.<br>The bits are set to 1 and cleared by the software.<br>00: Disable noise and triangle wave;<br>01: Enable the noise function;<br>1x: Enable the triangle wave function.  |
| 21:19     | T2SEL[2:0]  | DAC2 triggers selection.<br>This bit is used for selection of DAC2 external triggers.<br>000: TIM6 TRGO event;<br>001: TIM8 TRGO event;<br>010: TIM7 TRGO event;<br>011: TIM5 TRGO event;<br>100: TIM2 TRGO event;<br>101: TIM4 TRGO event;<br>110: External interrupt line 9;<br>111: Software trigger.  |
| 18        | T2EN        | DAC2 trigger on<br>This bit is set to 1 and cleared by the software to enable/disable DAC2 trigger.<br>0: Disable DAC2 trigger;<br>1: Enable DAC2 trigger.  |
| 17        | B2EN        | Enable the DAC2 output buffer.<br>This bit is set to 1 and cleared by the software to enable/disable the DAC2's output buffer.<br>0: Disable the DAC2 output buffer;<br>1: Enable the DAC2 output buffer.   |
| 16        | CH2EN       | DAC2 on   |

| Bit field | Name        | Description  |
|-----------|-------------|--|
|           |             | This bit is set to 1 and cleared by the software to enable/disable the DAC2.<br>0: Disable the DAC2;<br>1: Enable the DAC2.  |
| 15:13     | Reserved    | Reserved, the reset value must be maintained.  |
| 12        | DMA1EN      | The DMA function of the DAC1 is enabled<br>The bit is set to 1 and cleared by the software.<br>0: Disable DMA for the DAC1;<br>1: Enable DMA for the DAC1.   |
| 11:8      | MA1SEL[3:0] | DAC1 shield/amplitude selector.<br>These bits are configured by software to set the LFSR shielding bits for the noise function and the amplitude of the triangular wave.<br>0000: unmasked LFSR bit 0 / triangular amplitude equals 1;<br>0001: unmasked LFSR LFSR bit [1:0] / triangular amplitude equal 3;<br>0010: unmasked LFSR bit [2:0] / triangular amplitude equals 7;<br>0011: unmasked LFSR bit [3:0] / triangular amplitude equals 15;<br>0100: unmasked LFSR bit [4:0] / triangular amplitude equals 31;<br>0101: unmasked LFSR bit [5:0] / triangular amplitude equals 63;<br>0110: unmasked LFSR bit [6:0] / triangular amplitude equals 127;<br>0111: unmasked LFSR bit [7:0] / triangular amplitude equals 255;<br>1000: unmasked LFSR bit [8:0] / triangular amplitude equals 511;<br>1001: unmasked LFSR bit [9:0] / triangular amplitude equals 1023;<br>1010: unmasked LFSR bit [10:0] / triangular amplitude equals 2047;<br>≥1011: unmasked LFSR bit [11:0] / triangular amplitude equal 4095. |
| 7:6       | W1EN[1:0]   | DAC1 noise/triangle wave function selection.<br>The bits are set to 1 and cleared by the software.<br>00: Disable noise and triangle wave;<br>01: Enable the noise function;<br>1x: Enable the triangle wave function.   |
| 5:3       | T1SEL[2:0]  | DAC1 triggers selection.<br>This bit is used for selection of DAC1 external triggers.<br>000: TIM6 TRGO event;<br>001: TIM8 TRGO event;<br>010: TIM7 TRGO event;<br>011: TIM5 TRGO event;<br>100: TIM2 TRGO event;<br>101: TIM4 TRGO event;<br>110: External interrupt line 9;<br>111: Software trigger.   |
| 2         | T1EN        | DAC1 trigger on<br>This bit is set to 1 and cleared by the software to enable/disable DAC2 trigger.<br>0: Disable DAC1 trigger;<br>1: Enable DAC1 trigger.   |
| 1         | B1EN        | Enable the DAC1 output buffer.   |

| Bit field | Name  | Description   |
|-----------|-------|---|
|           |       | This bit is set to 1 and cleared by the software to enable/disable the DAC1's output buffer.<br>0: Disable the DAC1 output buffer;<br>1: Enable the DAC1 output buffer. |
| 0         | CH1EN | DAC1 on<br>This bit is set to 1 and cleared by the software to enable/disable the DAC2.<br>0: Disable the DAC1;<br>1: Enable the DAC1.                                  |

### 10.5.3 DAC software trigger register (DAC\_SOTTR)

Offset address: 0x04

Reset value: 0x0000 0000

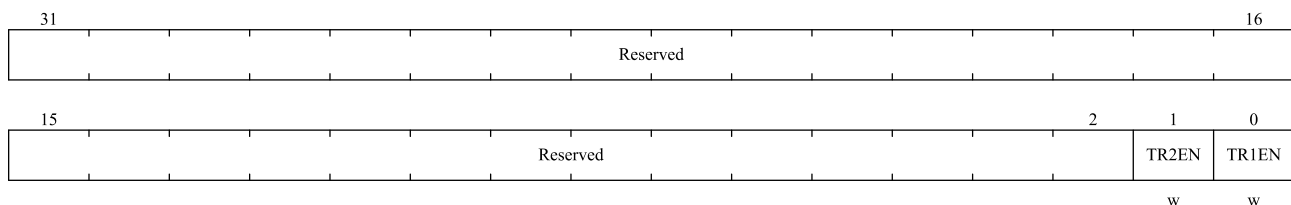

| Bit field | Name     | Description   |
|-----------|----------|---|
| 31:2      | Reserved | Reserved, the reset value must be maintained.   |
| 1         | TR2EN    | The DAC2 software trigger.<br>This bit is setting by software to enable/disable software trigger.<br>0: Disable the DAC2 software trigger.<br>1: Enable the DAC2 software trigger.<br><i>Note: After the alignment data hold register transfers data to the DAC_DATO2 register, this bit will be cleared by the hardware after an APB1 clock.</i> |
| 0         | TR1EN    | The DAC1 software trigger.<br>This bit is setting by software to enable/disable software trigger.<br>0: Disable the DAC1 software trigger.<br>1: Enable the DAC1 software trigger.<br><i>Note: After the alignment data hold register transfers data to the DAC_DATO1 register, this bit will be cleared by the hardware after an APB1 clock.</i> |

### 10.5.4 12 bit right aligned data hold register for DAC1 (DAC\_DR12CH1)

Offset address: 0x08

Reset value: 0x0000 0000

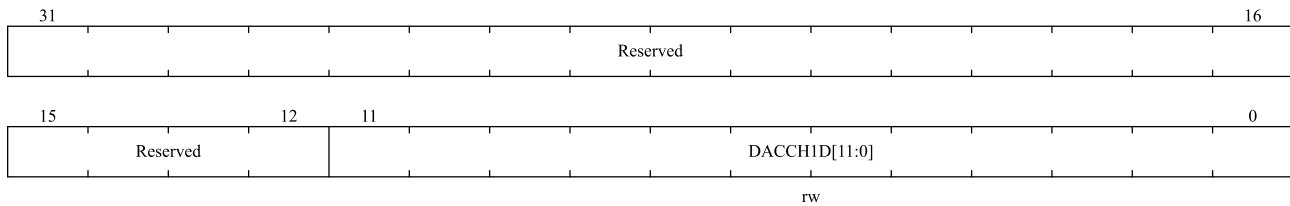

| Bit field | Name          | Description  |
|-----------|---------------|--|
| 31:12     | Reserved      | Reserved, the reset value must be maintained.  |
| 11:0      | DACCH1D[11:0] | 12-bit right- aligned data for DAC1<br>The bits are configured by the software and the DAC1 converts the data. |

### 10.5.5 12 bit left aligned data hold register for DAC1 (DAC\_DL12CH1)

Offset address: 0x0c

Reset value: 0x0000 0000

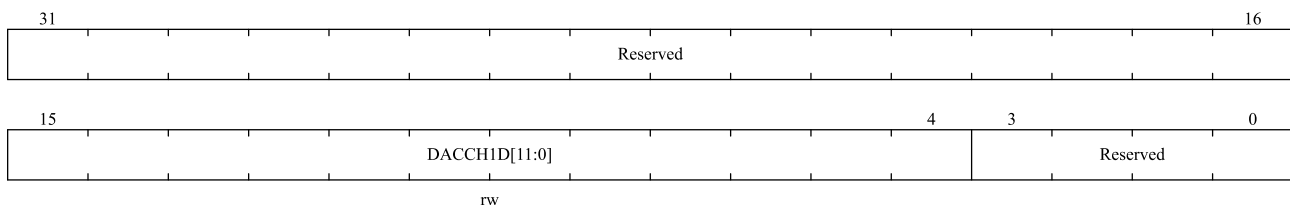

| Bit field | Name          | Description  |
|-----------|---------------|--|
| 31:16     | Reserved      | Reserved, the reset value must be maintained.  |
| 15:4      | DACCH1D[11:0] | 12-bit left-aligned data for DAC1<br>The bits are configured by the software and the DAC1 converts the data. |
| 3:0       | Reserved      | Reserved, the reset value must be maintained.  |

### 10.5.6 8-bit right-aligned data hold register for DAC1 (DAC\_DR8CH1)

Offset address: 0x10

Reset value: 0x0000 0000

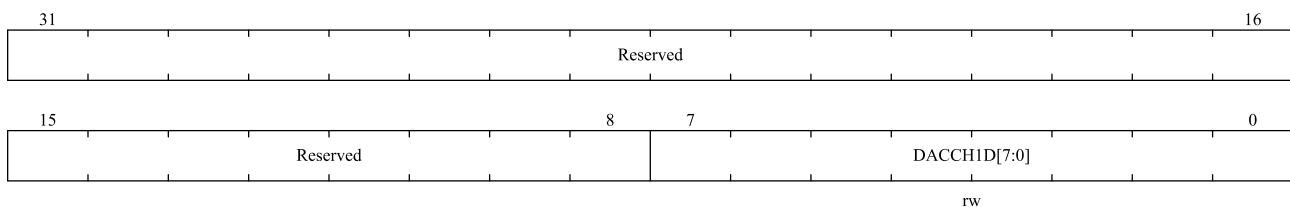

| Bit field | Name         | Description   |
|-----------|--------------|---|
| 31:8      | Reserved     | Reserved, the reset value must be maintained.   |
| 7:0       | DACCH1D[7:0] | 8-bit right- aligned data for DAC1<br>The bits are configured by the software and the DAC1 converts the data. |

### 10.5.7 12 bit right aligned data hold register for DAC2 (DAC\_DR12CH2)

Offset address: 0x14

Reset value: 0x0000 0000

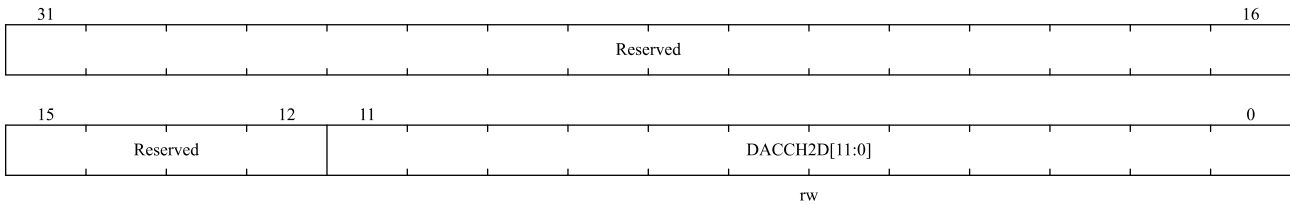

| Bit field | Name          | Description  |
|-----------|---------------|--|
| 31:12     | Reserved      | Reserved, the reset value must be maintained.  |
| 11:0      | DACCH2D[11:0] | 12-bit right- aligned data for DAC2<br>The bits are configured by the software and the DAC2 converts the data. |

### 10.5.8 12 bit left aligned data hold register for DAC2 (DAC\_DL12CH2)

Offset address: 0x18

Reset value: 0x0000 0000

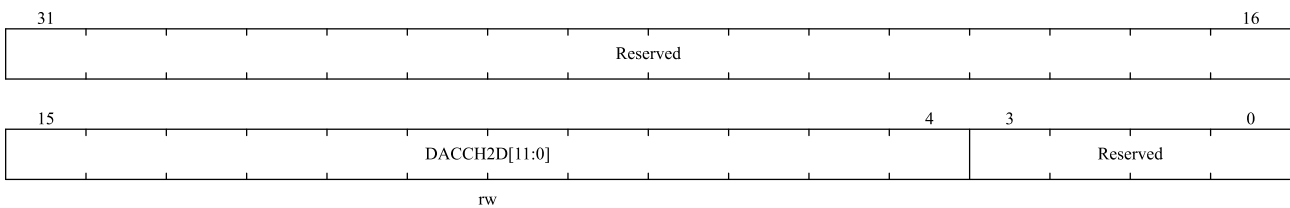

| Bit field | Name          | Description  |
|-----------|---------------|--|
| 31:16     | Reserved      | Retained, the reset value must be maintained.  |
| 15:4      | DACCH2D[11:0] | 12-bit left-aligned data for DAC2<br>The bits are configured by the software and the DAC2 converts the data. |
| 3:0       | Reserved      | Retained, the reset value must be maintained.  |

### 10.5.9 8-bit right-aligned data hold register for DAC2 (DAC\_DR8CH2)

Offset address: 0x1C

Reset value: 0x0000 0000

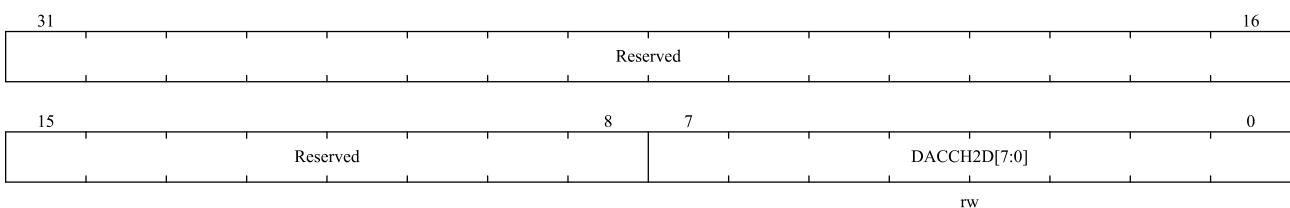

| Bit field | Name         | Description   |
|-----------|--------------|---|
| 31:8      | Reserved     | Retained, the reset value must be maintained.   |
| 7:0       | DACCH2D[7:0] | 8-bit right- aligned data for DAC2<br>The bits are configured by the software and the DAC2 converts the data. |

### 10.5.10 12 bit right aligned data hold register for dual DAC (DAC\_DR12DCH)

Offset address: 0x20

Reset value: 0x0000 0000

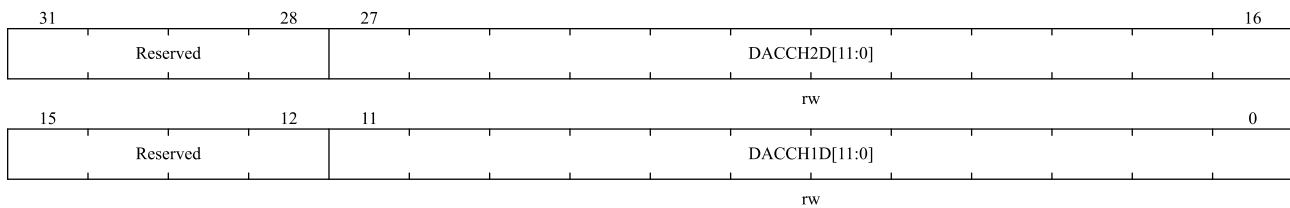

| Bit field | Name          | Description  |
|-----------|---------------|--|
| 31:28     | Reserved      | Retained, the reset value must be maintained.  |
| 27:16     | DACCH2D[11:0] | 12-bit right- aligned data for DAC2<br>The bits are configured by the software and the DAC2 converts the data. |
| 15:12     | Reserved      | Retained, the reset value must be maintained.  |
| 11:0      | DACCH1D[11:0] | 12-bit right- aligned data for DAC1<br>The bits are configured by the software and the DAC1 converts the data. |

### 10.5.11 12 bit left aligned data hold register for dual DAC (DAC\_DL12DCH)

Offset address: 0x24

Reset value: 0x0000 0000

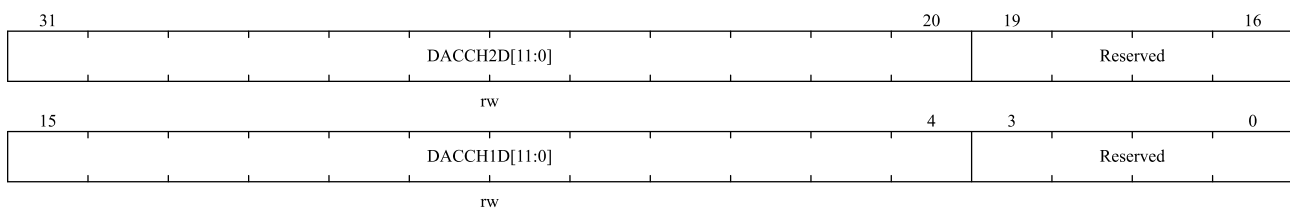

| Bit field | Name          | Description   |
|-----------|---------------|---|
| 31:20     | DACCH2D[11:0] | 12-bit left- aligned data for DAC2<br>The bits are configured by the software and the DAC2 converts the data. |
| 19:16     | Reserved      | Retained, the reset value must be maintained.   |
| 15:4      | DACCH1D[11:0] | 12-bit left- aligned data for DAC1<br>The bits are configured by the software and the DAC1 converts the data. |
| 3:0       | Reserved      | Retained, the reset value must be maintained.   |

### 10.5.12 8 bit right aligned data hold register for dual DAC (DAC\_DR8DCH)

Offset address: 0x28

Reset value: 0x0000 0000

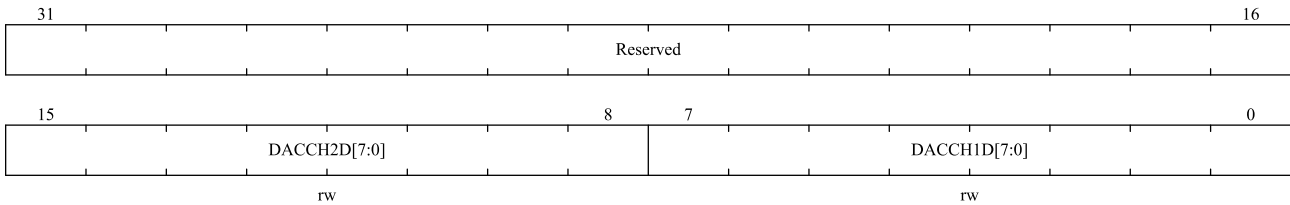

| Bit field | Name         | Description   |
|-----------|--------------|---|
| 31:16     | Reserved     | Retained, the reset value must be maintained.   |
| 15:8      | DACCH2D[7:0] | 8-bit right- aligned data for DAC2<br>The bits are configured by the software and the DAC2 converts the data. |
| 7:0       | DACCH1D[7:0] | 8-bit right- aligned data for DAC1<br>The bits are configured by the software and the DAC1 converts the data. |

### 10.5.13 DAC1 data output register (DAC\_DATO1)

Offset address: 0x2C

Reset value: 0x0000 0000

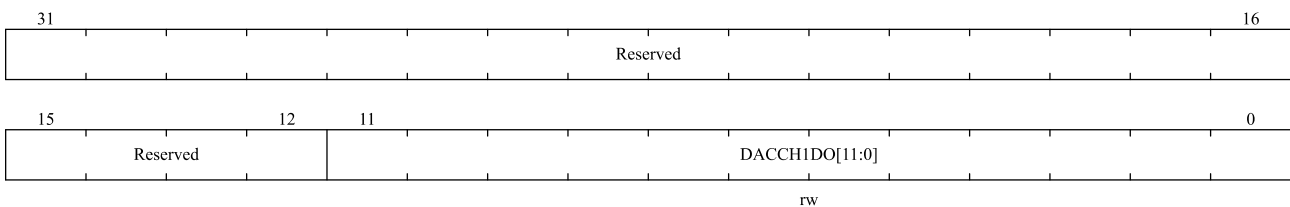

| Bit field | Name           | Description  |
|-----------|----------------|--|
| 31:12     | Reserved       | Retained, the reset value must be maintained.  |
| 11:0      | DACCH1DO[11:0] | DAC1 data output.<br>These bits are read-only and represent the output data of the DAC1. |

### 10.5.14 DAC2 data output register (DAC\_DATO2)

Offset address: 0x30

Reset value: 0x0000 0000

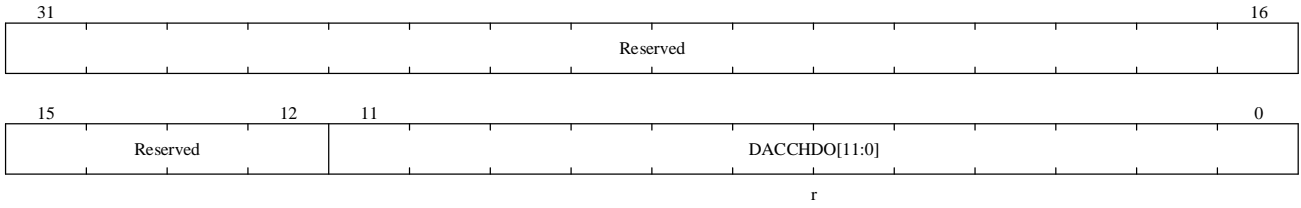

| Bit field | Name           | Description  |
|-----------|----------------|--|
| 31:12     | Reserved       | Retained, the reset value must be maintained.  |
| 11:0      | DACCH2DO[11:0] | DAC2 data output.<br>These bits are read-only and represent the output data of the DAC2. |

## 11 Advanced-control timers (TIM1 and TIM8)

### 11.1 TIM1 and TIM8 introduction

The advanced control timers (TIM1 and TIM8) is mainly used in the following occasions: counting the input signal, measuring the pulse width of the input signal and generating the output waveform, etc.

Advanced timers have complementary output function with dead-time insertion and break function. Suitable for motor control.

### 11.2 Main features of TIM1 and TIM8

- 16-bit auto-reload counters. (It can realize up-counting, down-counting, up/down counting).
- 16-bit programmable prescaler. (The frequency division factor can be configured with any value between 1 and 65536)
- Programmable Repetition Counter
- TIM1 up to 6 channels, TIM8 up to 6 channels.
- 4 capture/compare channels, the working modes are PWM output, output compare, one-pulse mode output, input capture.
- The events that generate the interrupt/DMA are as follows:
  - ◆ Update event
  - ◆ Trigger event
  - ◆ Input capture
  - ◆ Output compare
  - ◆ Break input
- Complementary outputs with adjustable dead-time.
  - For TIM1 and TIM8, channel 1,2,3 support this feature
- Timer can be controlled by external signal
- Timers can be linked together internally for timer synchronization or chaining
- TIM1\_CC5 and TIM8\_CC5 for COMP blanking.
- TIM1\_CC6 is used to switch the input channel of OPAMP1 and OPAMP2; TIM8\_CC6 is used to switch the input channel of OPAMP3 and OPAMP4;
- Incremental (quadrature) encoder interface: used for tracking motion and resolving rotation direction and position;
- Hall sensor interface: used to do three-phase motor control;

Figure 11-1 Block diagram of TIM1 and TIM8

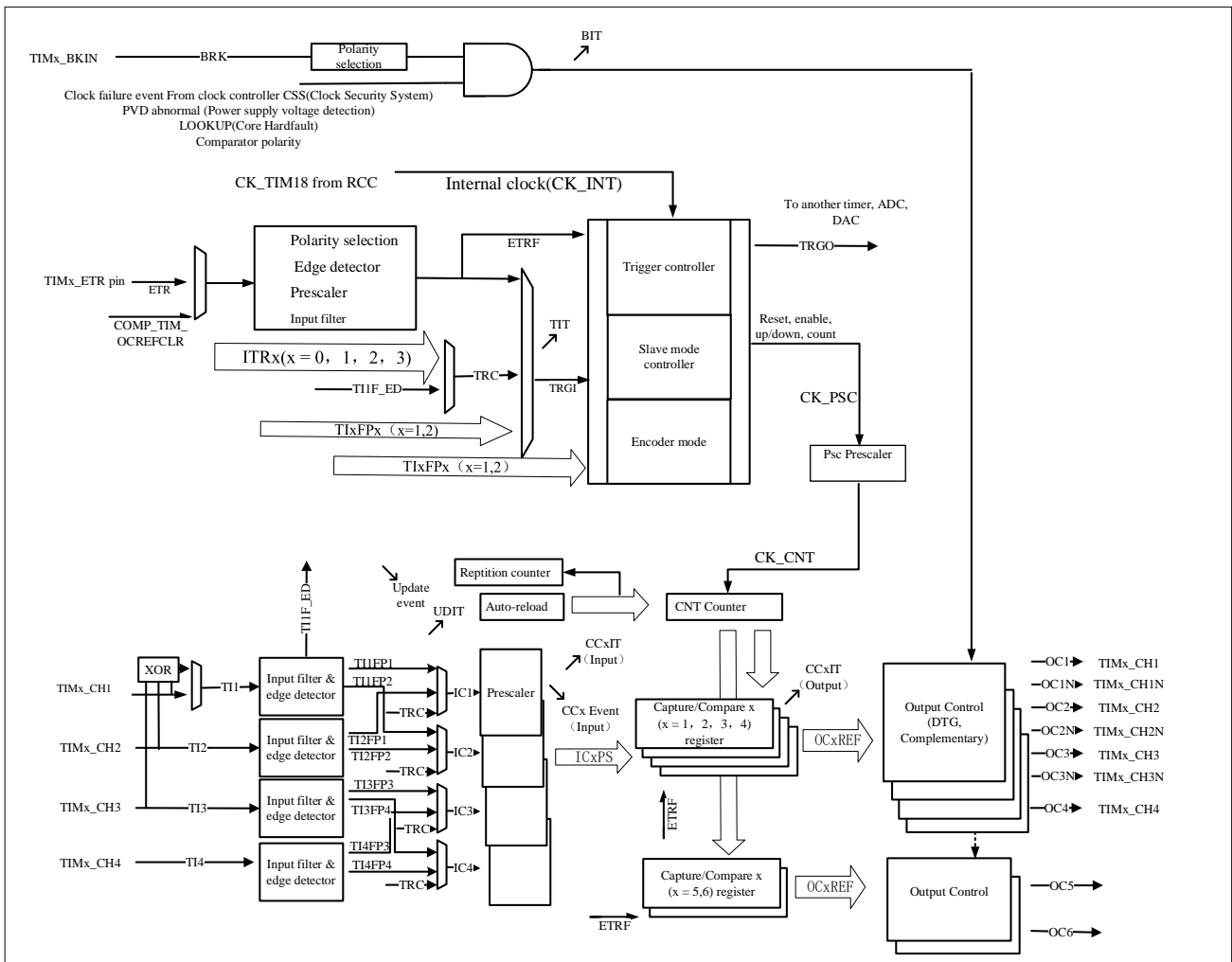

 The event
  Interrupt and DMA output

The capture channel 1 input can come from IOM or comparator output

## 11.3 TIM1 and TIM8 function description

### 11.3.1 Time-base unit

The advanced-control's time-base unit mainly includes: prescaler, counter, auto-reload and repetition counter. When the time base unit is working, the software can read and write the corresponding registers (TIMx\_PSC, TIMx\_CNT, TIMx\_AR and TIMx\_REPCNT) at any time.

Depending on the setting of the auto-reload preload enable bit (TIMx\_CTRL1.ARPEN), the value of the preload register is transferred to the shadow register immediately or at each update event UEV. An update event is generated when the counter reaches the overflow/underflow condition and it can be generated by software when TIMx\_CTRL1.UPDIS=0. The counter CK\_CNT is valid only when the TIMx\_CTRL1.CNTEN bit is set. The counter starts counting one clock cycle after the TIMx\_CTRL1.CNTEN bit is set.

### 11.3.1.1 Prescaler description

The TIMx\_PSC register consists of a 16-bit counter that can be used to divide the counter clock frequency by any factor between 1 and 65536. It can be changed on the fly as it is buffered. The prescaler value is only taken into account at the next update event.

Figure 11-2 Counter timing diagram with prescaler division change from 1 to 4

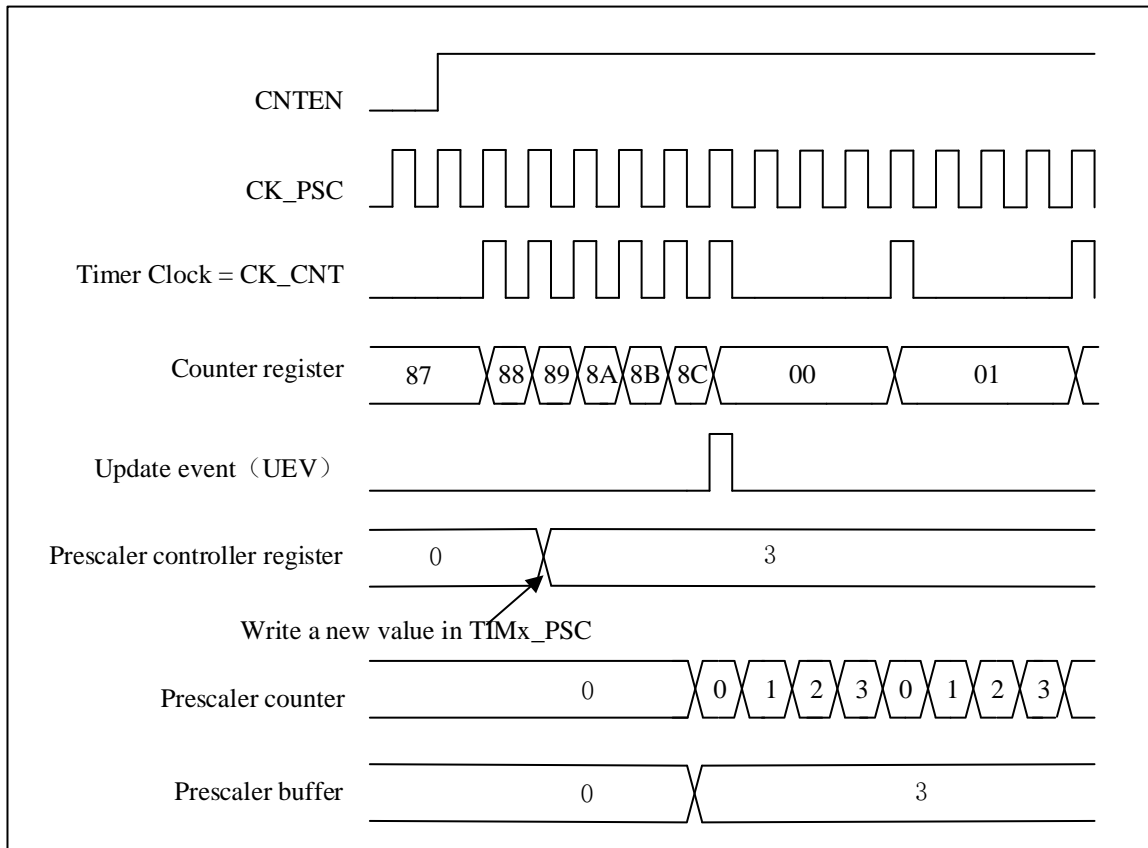

## 11.3.2 Counter mode

### 11.3.2.1 Up-counting mode

In up-counting mode, the counter will count from 0 to the value of the register TIMx\_AR, then it resets to 0. And a counter overflow event is generated.

If the TIMx\_CTRL1.UPRS bit (select update request) and the TIMx\_EVTGEN.UDGN bit are set, an update event (UEV) will generate. And TIMx\_STS.UDITF will not be set by hardware, therefore, no update interrupts or update DMA requests are generated. This setting is used in scenarios where you want to clear the counter but do not want to generate an update interrupt.

Depending on the update request source is configured in the TIMx\_CTRL1.UPRS, When an update event occurs, the TIMx\_STS.UDITF is set, all registers are updated:

- The repetition counter reloads the contents of the TIMx\_REPCNT
- Update auto-reload shadow registers with preload value(TIMx\_AR), when TIMx\_CTRL1.ARPEN = 1.
- The prescaler shadow register is reloaded with the preload value(TIMx\_PSC).

To avoid updating the shadow registers when new values are written to the preload registers, you can disable the update by setting `TIMx_CTRL1.UPDIS=1`.

When an update event occurs, the counter will still be cleared and the prescaler counter will also be set to 0 (but the prescaler value will remain unchanged).

The figure below shows some examples of the counter behavior and the update flags for different division factors in the up-counting mode.

Figure 11-3 Timing diagram of up-counting. The internal clock divider factor =  $2/N$

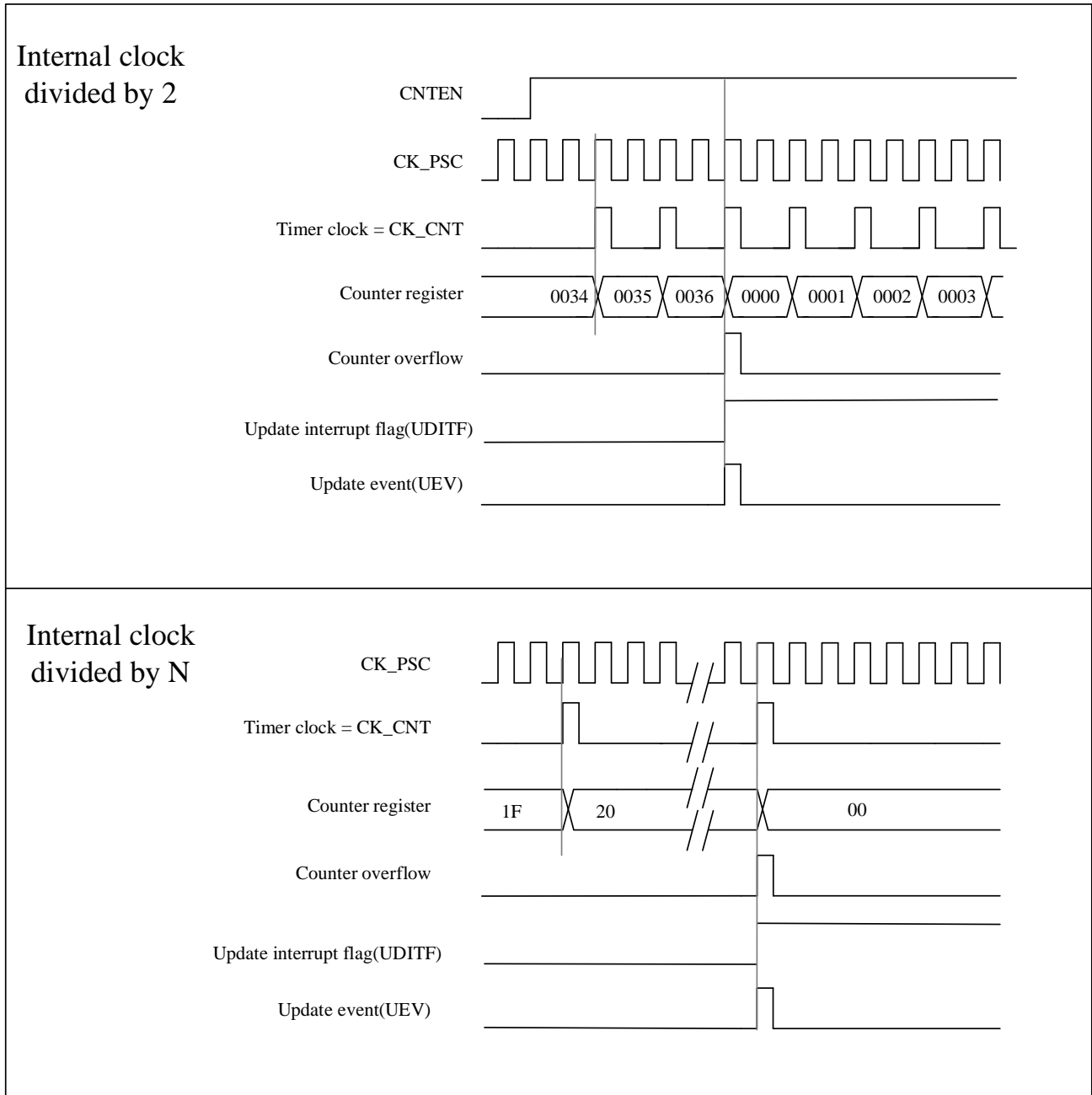
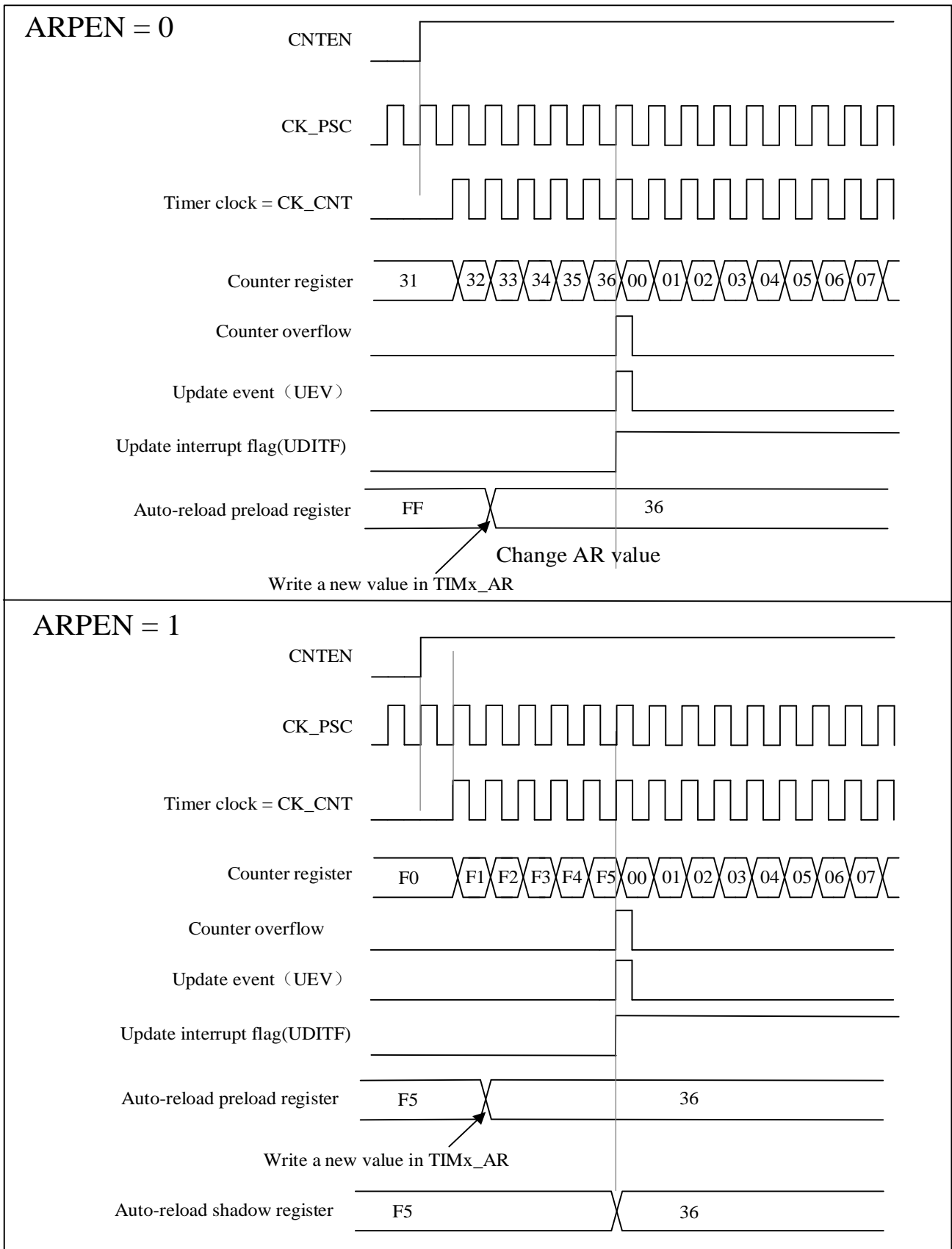

Figure 11-4 Timing diagram of the up-counting, update event when ARPEN=0/1



### 11.3.2.2 Down-counting mode

In down-counting mode, the counter will decrement from the value of the register TIMx\_AR to 0, then restart from the auto-reload value and generate a counter underflow event.

The process of configuring update events and updating registers in down-counting mode is the same as in up-counting mode, see 11.3.2.1.

The figure below shows some examples of the counter behavior and the update flags for different division factors in the down-counting mode.

Figure 11-5 Timing diagram of the down-counting, internal clock divided factor = 2/N

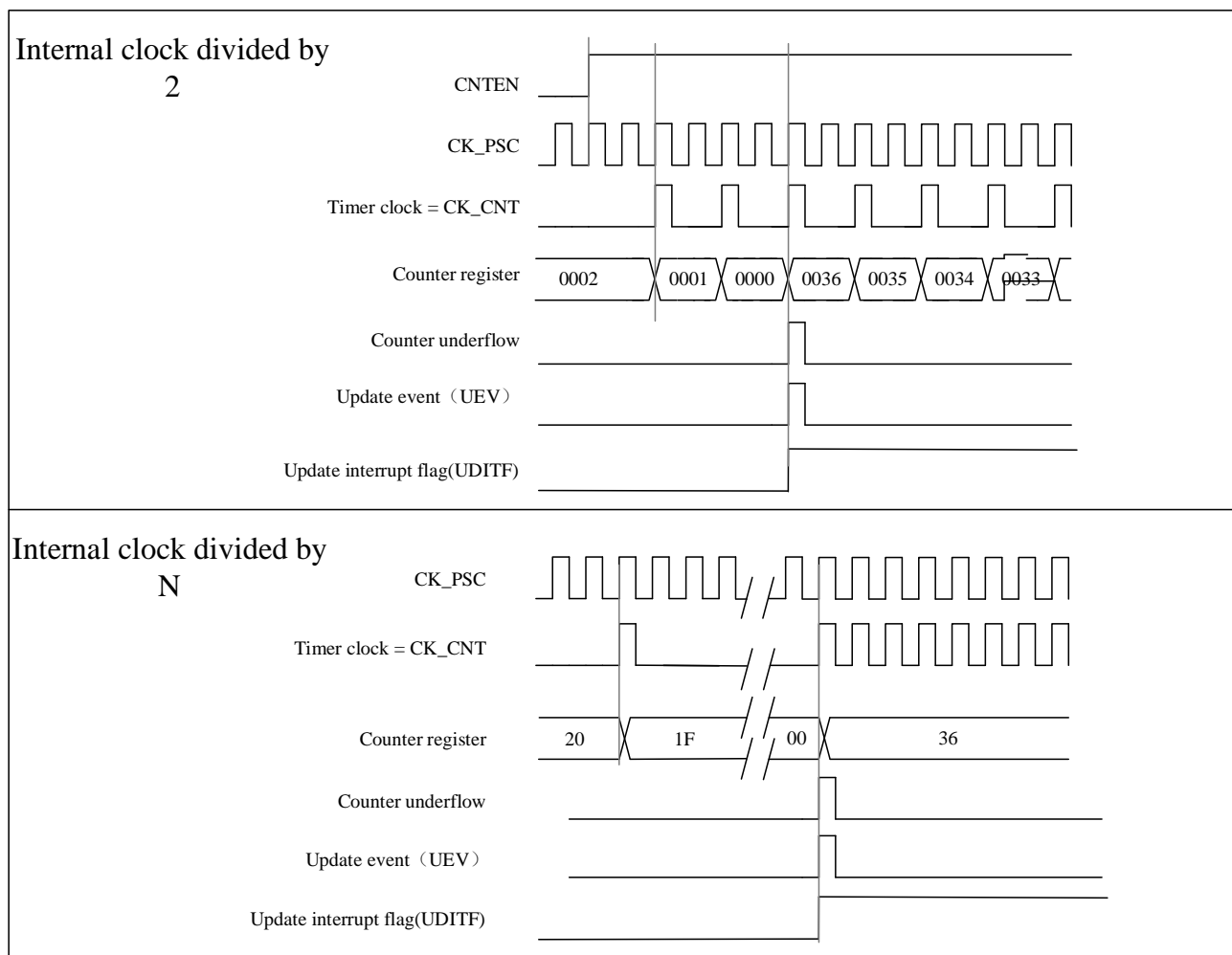

### 11.3.2.3 Center-aligned mode

In center-aligned mode, the counter increments from 0 to the value (TIMx\_AR) - 1, a counter overflow event is generated. It then counts down from the auto-reload value (TIMx\_AR) to 1 and generates a counter underflow event. Then the counter resets to 0 and starts counting up again.

In this mode, the TIMx\_CTRL1.DIR direction bits have no effect and the count direction is updated and specified by hardware. Center-aligned mode is valid when the TIMx\_CTRL1.CAMSEL bit is not equal to "00".

The update events can be generated each time the counter overflows and each time the counter underflows. Alternatively, an update event can also be generated by setting the TIMx\_EVTGEN.UDGN bit (either by software

or using a slave mode controller). In this case, the counter restarts from 0, as does the prescaler's counter.

Please note: if the update source is a counter overflow, auto-reload update before reloading the counter.

Figure 11-6 Timing diagram of the Center-aligned, internal clock divided factor =2/N

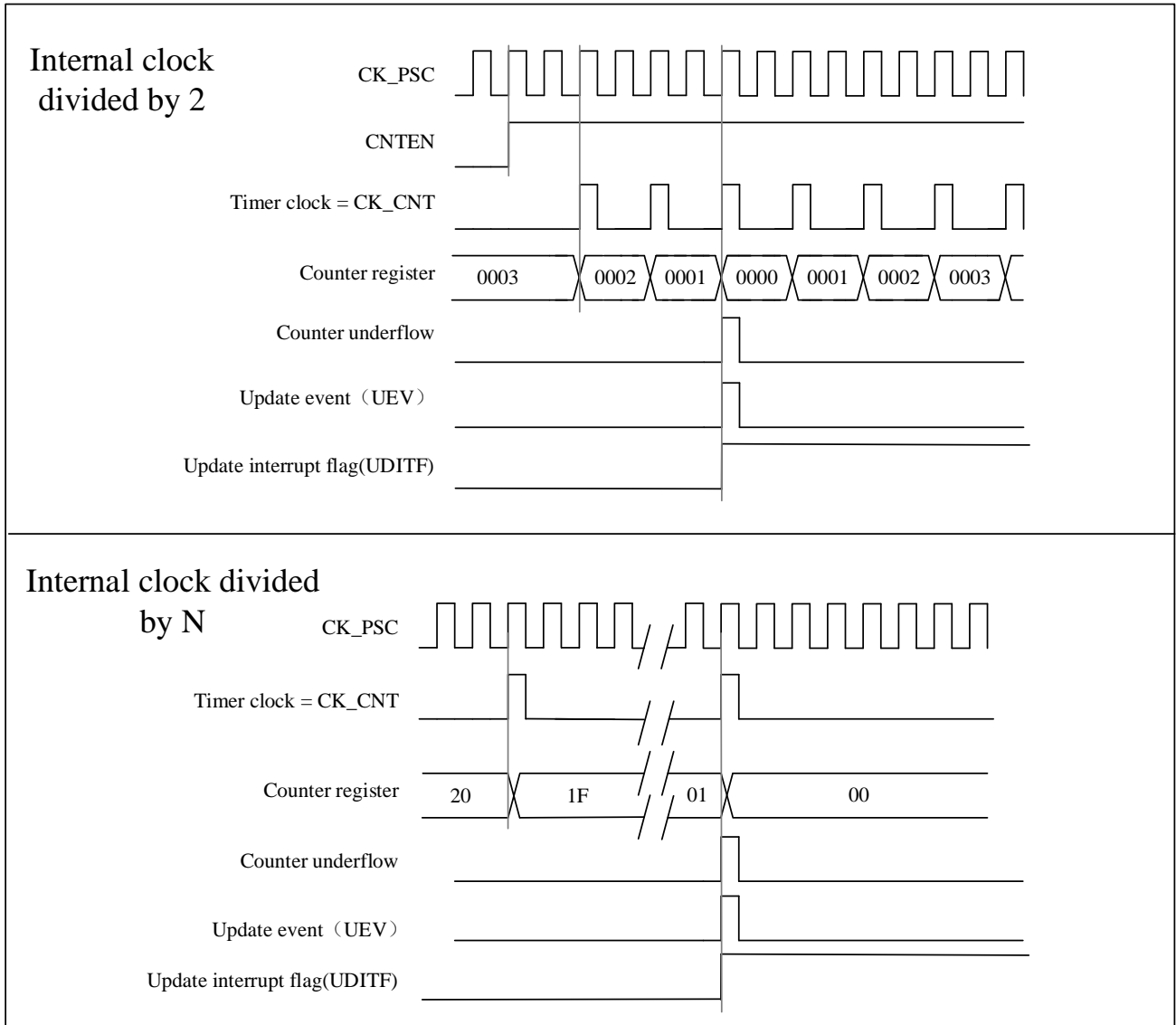
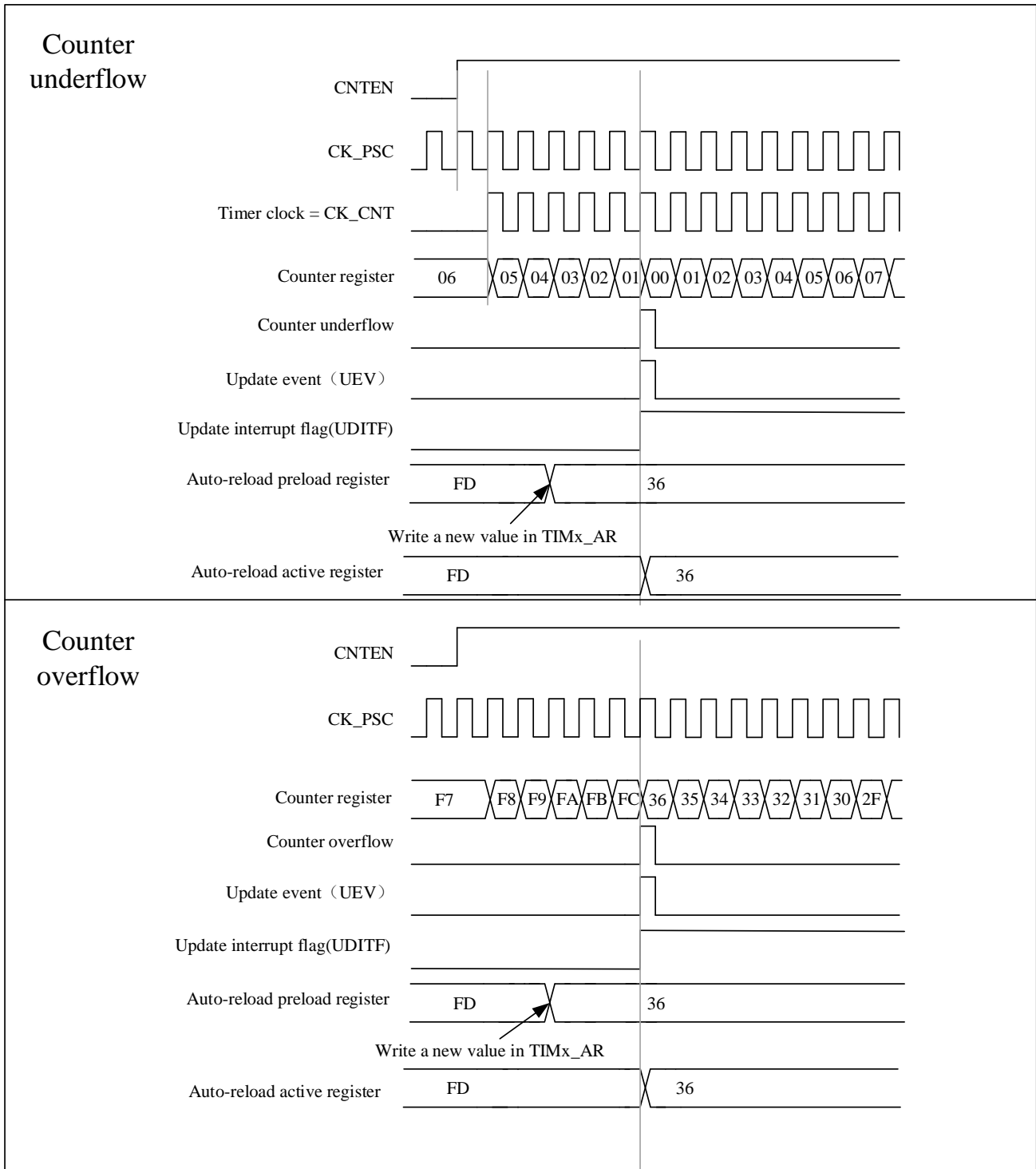

Figure 11-7 A center-aligned sequence diagram that includes counter overflows and underflows (ARPEN = 1)



### 11.3.3 Repetition counter

The basic unit of Section 11.3.1 describes the conditions for generating an update event (UEV). An update event (UEV) is actually only generated when the repeat counter reaches zero, which is valuable for generating PWM signals.

This means that data is transferred from the preload registers to the shadow registers every  $N+1$  counter overflow or underflow, where  $N$  is the value in the TIMx\_REPCNT.

The repetition counter is decremented:

- In the up-counting mode, each time the counter reaches the maximum value, an overflow occurs.
- In down-counting mode, each time the counter decrements to the minimum value, an underflow occurs.
- In center-aligned mode, each time the counter overflows or underflows.

Its repetition rate is defined by the value of the TIMx\_REPCNT register.

Repetition counters feature automatic reloading. The update event ( generated by setting TIMx\_EVTGEN.UDGN or hardware through slave mode controller) occurs immediately, regardless of the value of the repeat counter.

Figure 11-8 Repeat count sequence diagram in down-counting mode

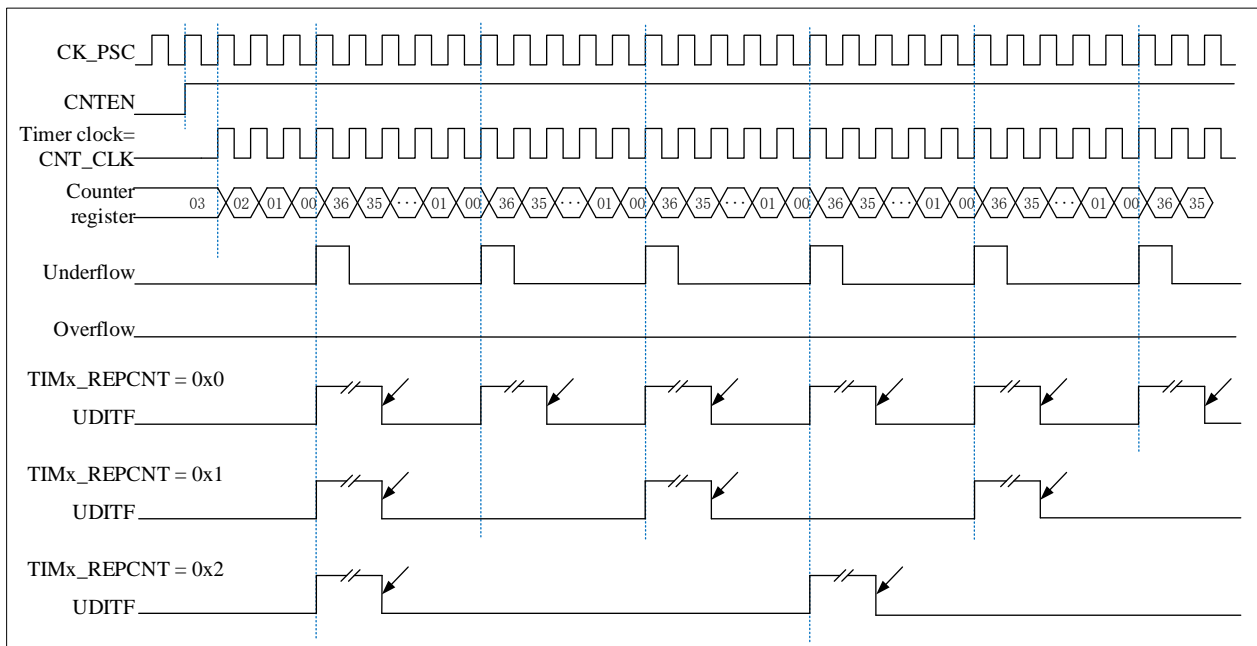

↙  
Software clear

Figure 11-9 Repeat count sequence diagram in up-counting mode

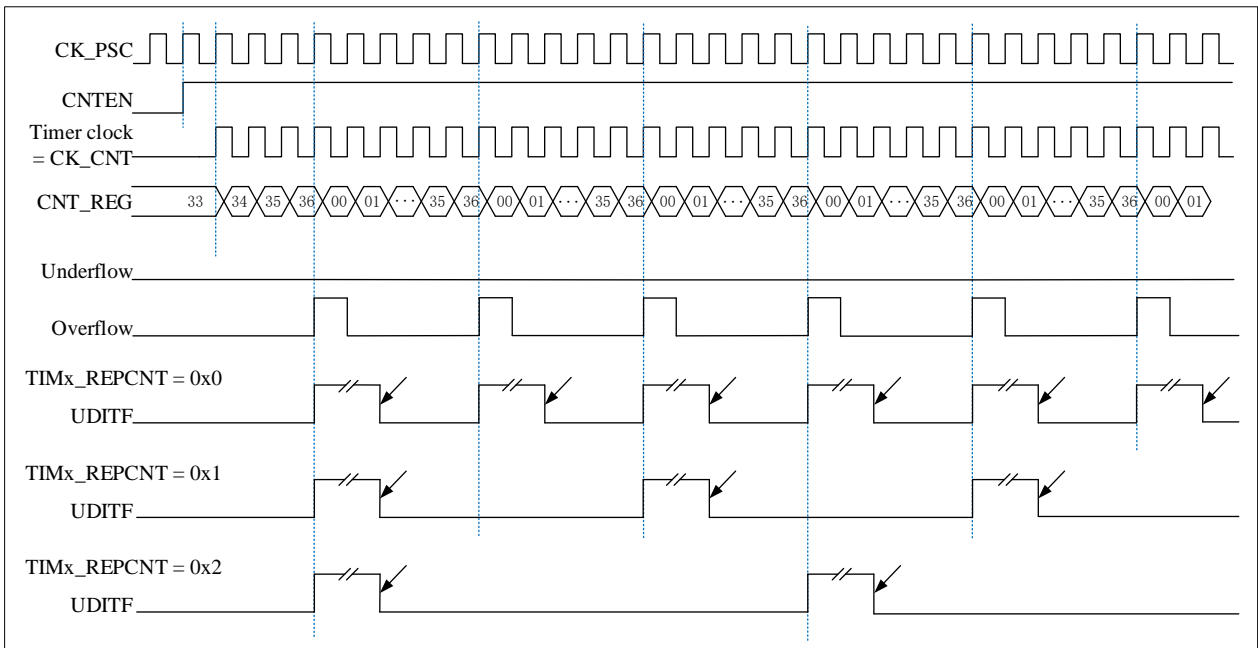

↙  
Software clear

Figure 11-10 Repeat count sequence diagram in center-aligned mode

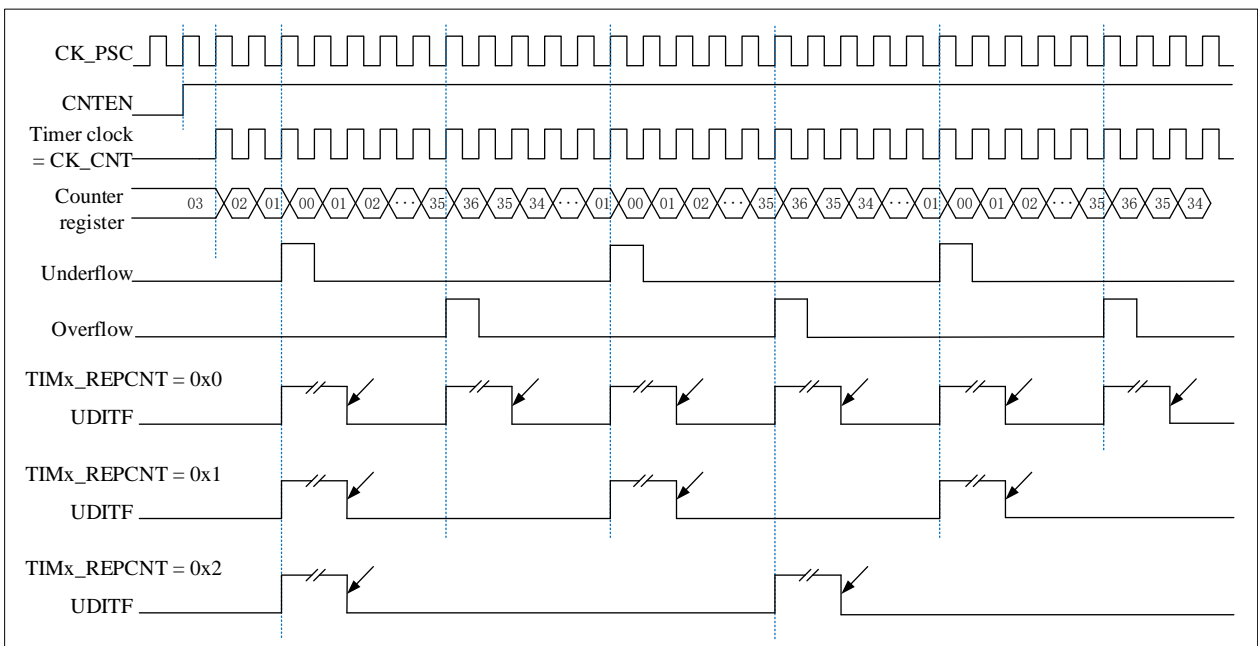

↙  
Software clear

### 11.3.4 Clock selection

- The internal clock of Advanced-control timers : CK\_INT
- Two kinds of external clock mode :
  - external input pin
  - external trigger input ETR
- Internal trigger input (ITRx): one timer is used as a prescaler for another timer.

#### 11.3.4.1 Internal clock source (CK\_INT)

When the TIMx\_SMCTRL.SMSEL is equal to “000”, the slave mode controller is disabled. The three control bits (TIMx\_CTRL1.CNTEN、TIMx\_CTRL1.DIR、TIMx\_EVTGEN.UDGN) can only be changed by software (except TIMx\_EVTGEN.UDGN, which remains cleared automatically ). It is provided that the TIMx\_CTRL1.CNTEN bit is written as '1' by soft, the clock source of the prescaler is provided by the internal clock CK\_INT.

Figure 11-11 Control circuit in normal mode, internal clock divided by 1

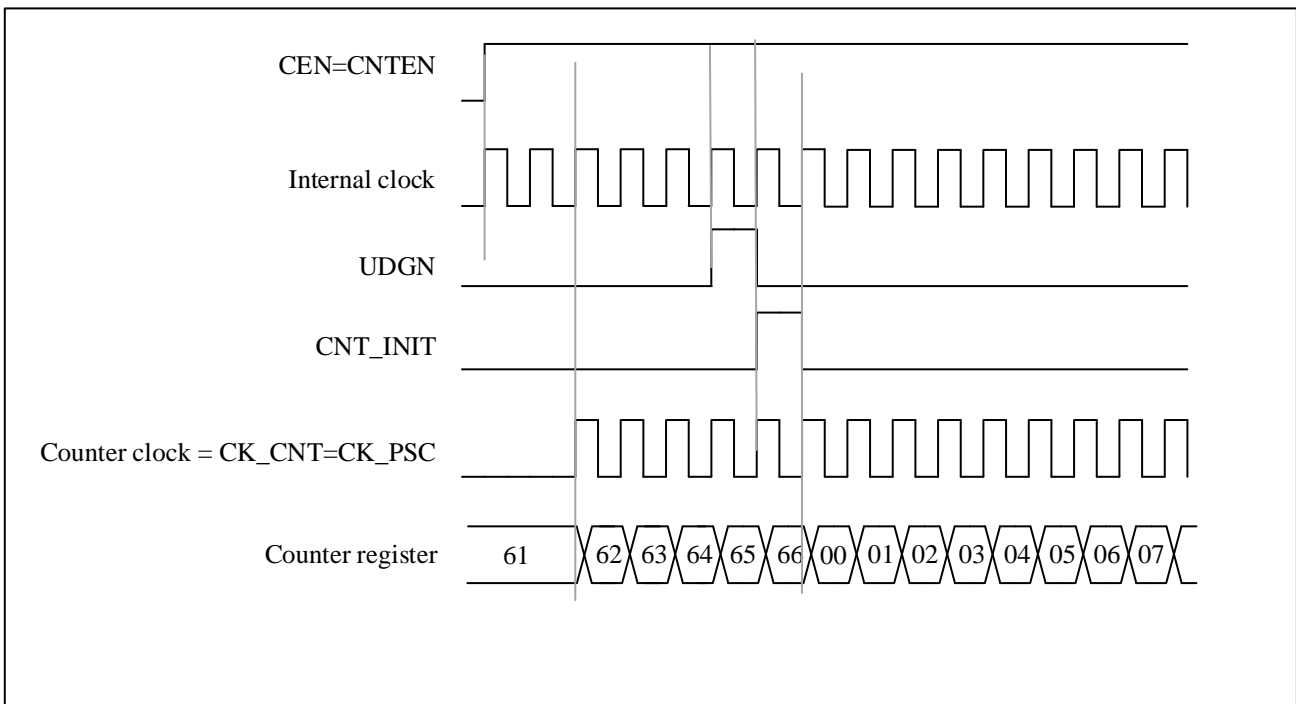

### 11.3.4.2 External clock source mode 1

Figure 11-12 TI2 external clock connection example

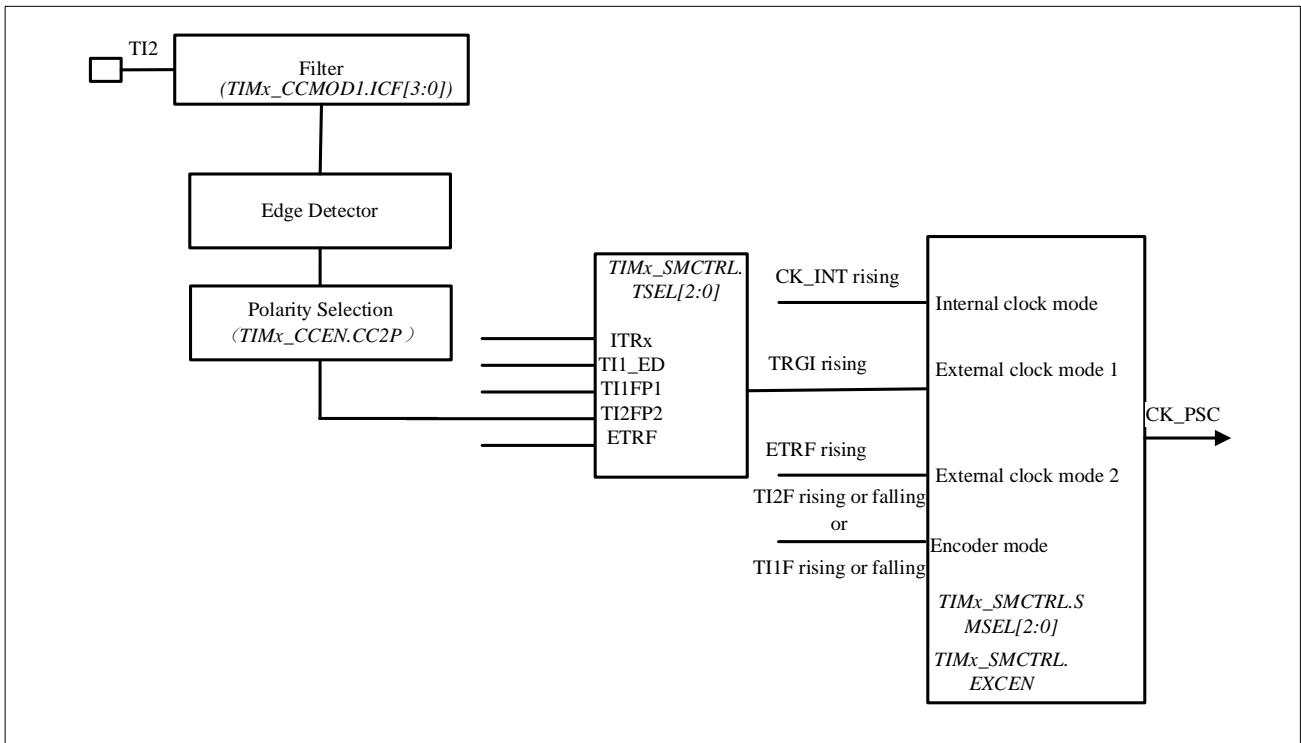

This mode is selected by configuring `TIMx_SMCTRL.SMSEL=111`. The counter can be configured to count on the rising or falling edge of the clock at the selected input.

For example, to configure up-counting mode to count on the rising edge of the clock at the T12 input, the configuration steps are as follows:

- Configure `TIMx_CCMOD1.CC2SEL` equal to '01', CC2 channel is configured as input, IC2 is mapped to TI2
- Configure `TIMx_CCEN.CC2P` equal to '0', select clock rising edge polarity
- To select input filter bandwidth by configuring `TIMx_CCMOD1.IC2F[3:0]` (if filter is not needed, keep IC2F bit at '0000')
- Configure `TIMx_SMCTRL.SMSEL` equal to '111', select timer external clock mode 1
- Configure `TIMx_SMCTRL.TSEL` equal to '110', select TI2 as the trigger input source
- Configure `TIMx_CTRL1.CNTEN` equal to '1' to start the counter

*Note: The capture prescaler is not used for triggering, so it does not need to be configured*

When the rising edge of the timer clock occurs at `TI2=1`, the counter counts once and the `TIMx_STS.TITF` flag is pulled high.

The delay between the rising edge of TI2 and the actual clock of the counter depends on the resynchronization circuit at the input of TI2.

Figure 11-13 Control circuit in external clock mode 1

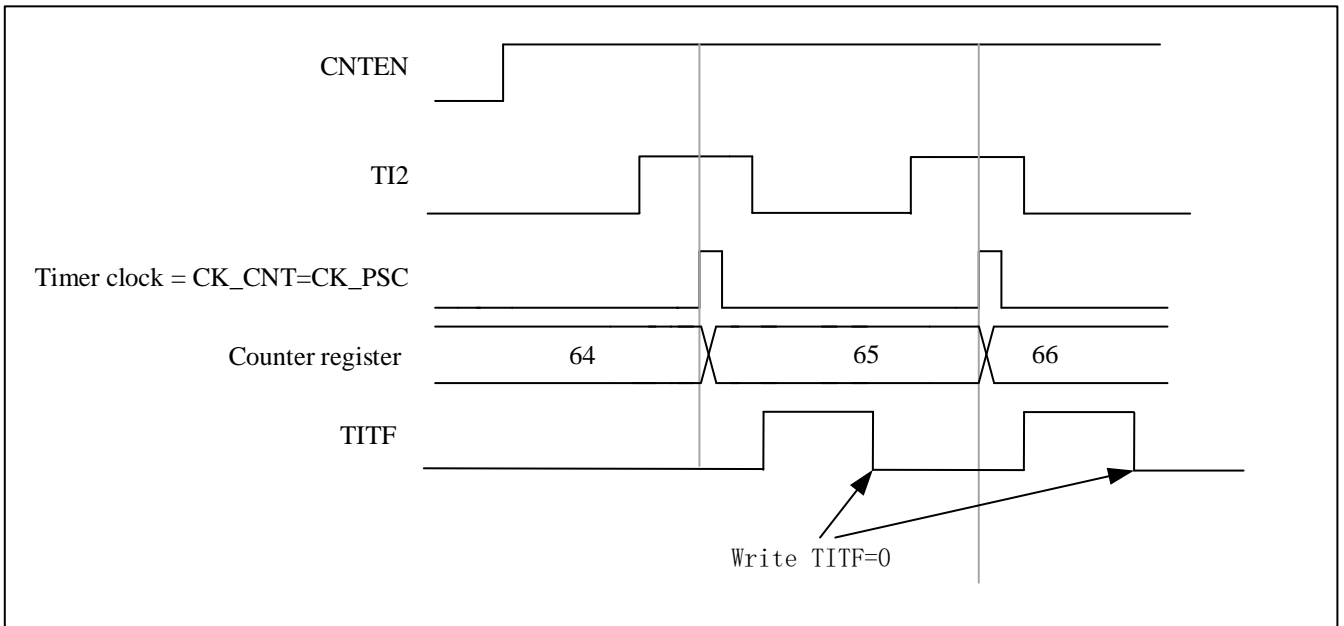

### 11.3.4.3 External clock source mode 2

This mode is selected by `TIMx_SMCTRL.EXCEN` equal to 1. The counter can count on every rising or falling edge of the external trigger input ETR.

The following figure is a schematic diagram of the external trigger input module in External clock source mode 2

Figure 11-14 External trigger input block diagram

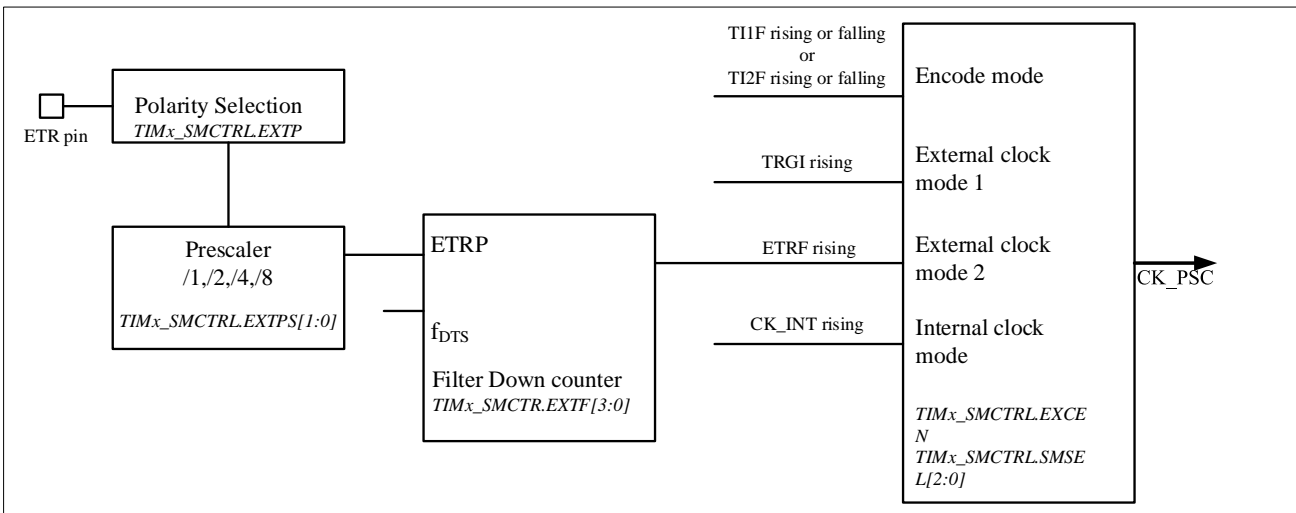

For example, use the following configuration steps to make the up counter count every 2 rising edges on ETR.

- Since no filter is needed in this case, make `TIMx_SMCTRL.EXTF[3:0]` equal to '0000'
- Configure the prescaler by making `TIMx_SMCTRL.EXTPS[1:0]` equal to '01'
- Select the polarity on ETR pin by setting `TIMx_SMCTRL.EXTP` equal to '0', The rising edge of ETR is valid

- External clock mode 2 is selected by setting TIMx\_SMCTRL .EXCEN equal to '1'
- Turn on the counter by setting TIMx\_CTRL1. CNTEN equal to '1'

The counter counts every 2 rising edges of ETR. The delay between the rising edge of ETR and the actual clock to the counter is due to a resynchronization circuit on the ETRP signal.

Figure 11-15 Control circuit in external clock mode 2

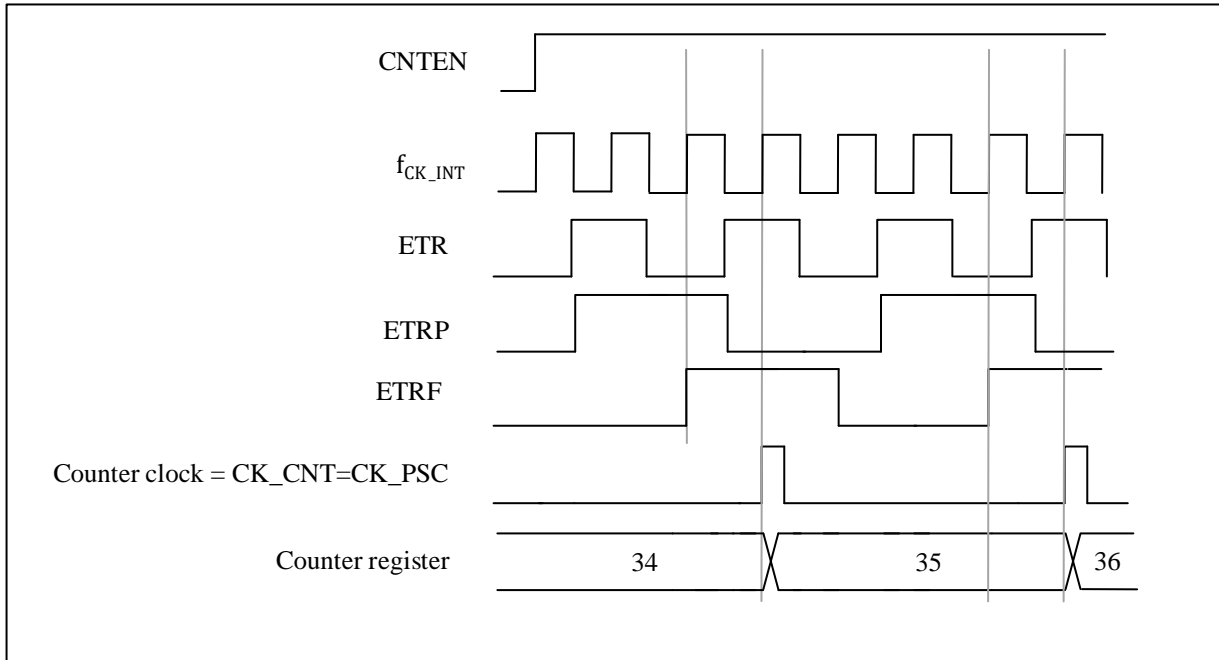

### 11.3.5 Capture/compare channels

Capture/compare channels include capture/compare registers and shadow registers. The input section consists of digital filters, multiplexers and prescalers. The output section includes comparators and output controls.

The input signal TIx is sampled and filtered to generate the signal TIxF. A signal (TIxF\_rising or TIxF\_falling) is then generated by the edge detector of the polarity select function, the polarity of which is selected by the TIMx\_CCEN.CCxP bits. This signal can be used as a trigger input for the slave mode controller. At the same time, the signal ICx is sent to the capture register after frequency division. The following figure shows a block diagram of a capture/compare channel.

Figure 11-16 Capture/compare channel (example: channel 1 input stage)

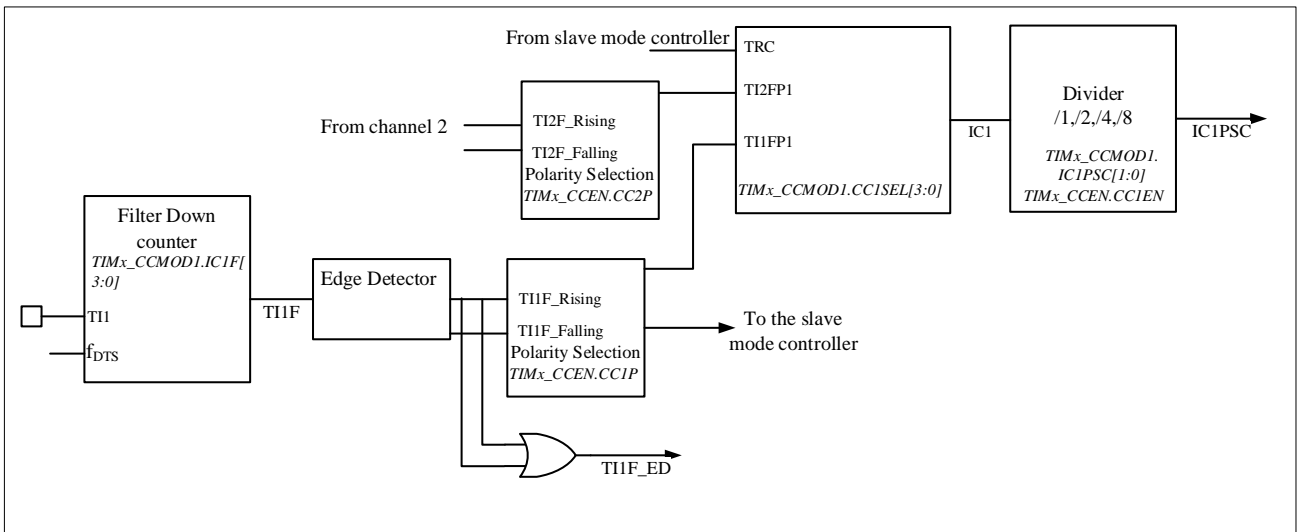

The output part generates an intermediate waveform OCxRef (active high) as reference. The polarity acts at the end of the chain.

Figure 11-17 Capture/compare channel 1 main circuit

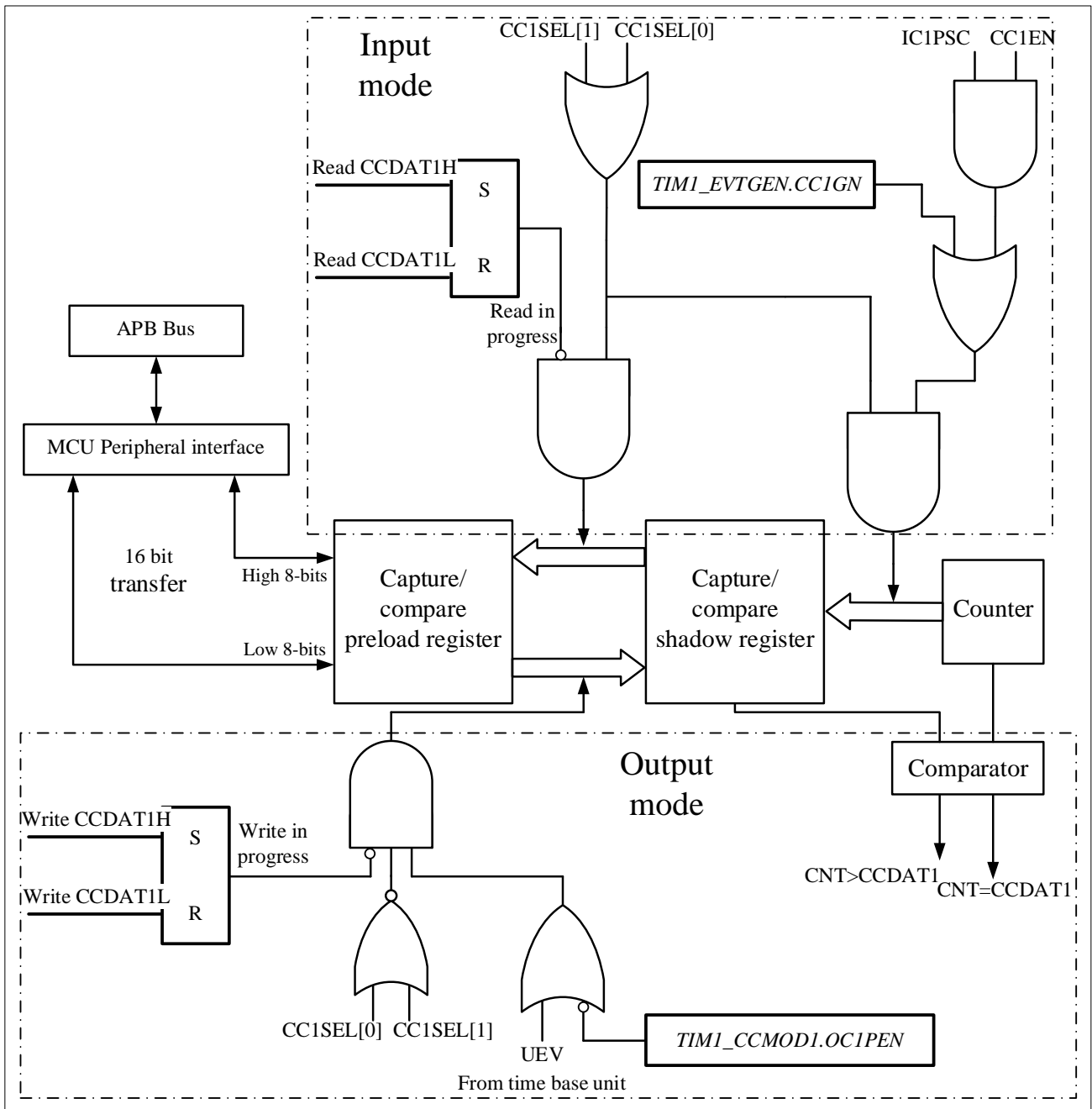

Figure 11-18 Output part of channelx (x= 1,2,3, take channel 1 as example)

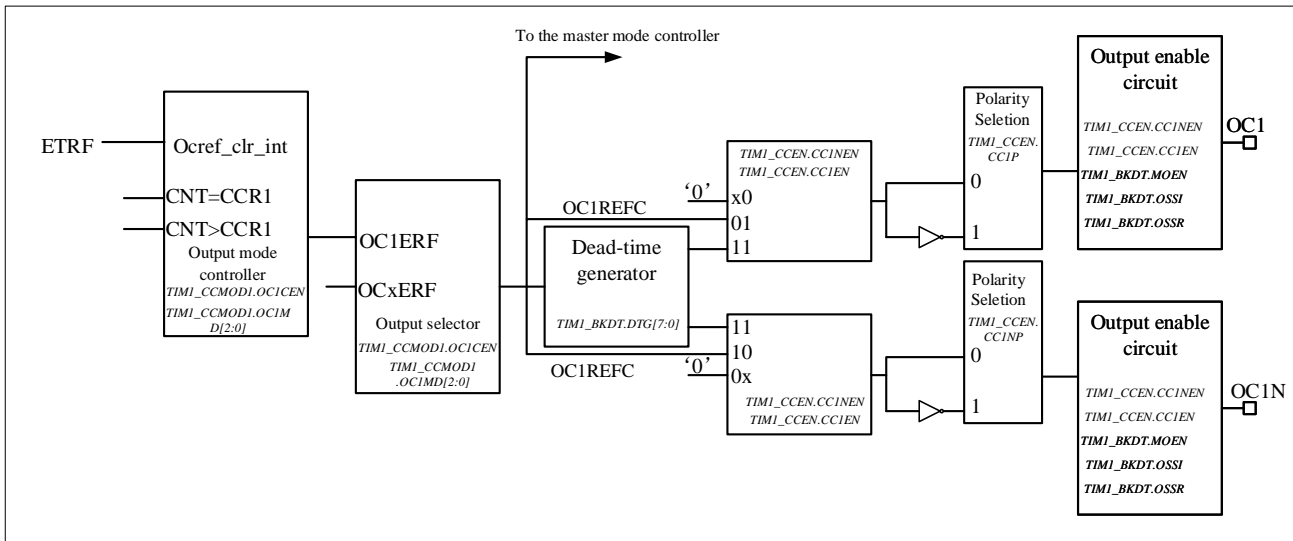
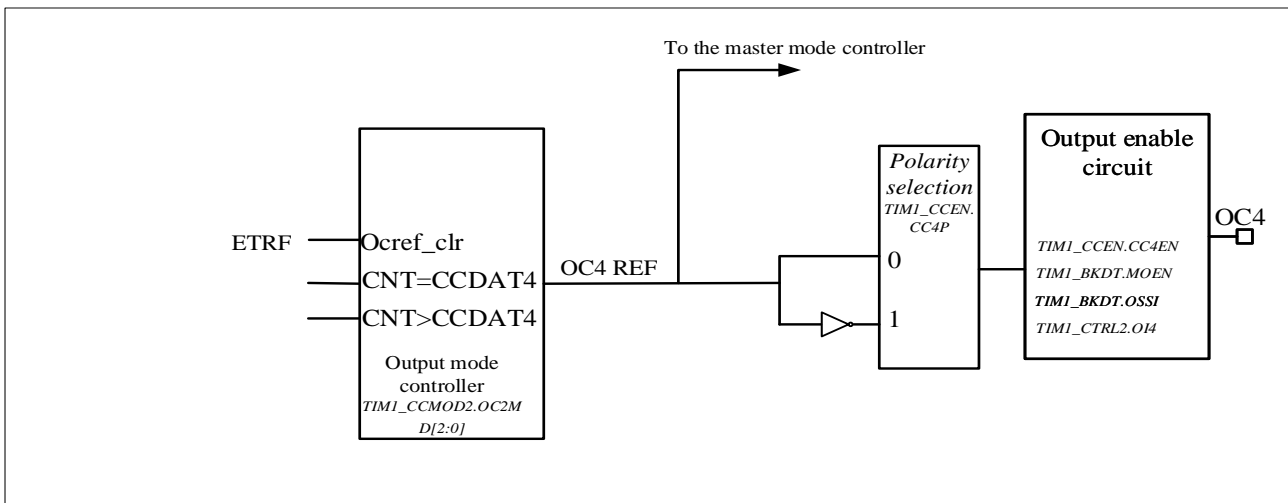

Figure 11-19 Output part of channelx (x= 4)



Reads and writes always access preloaded registers when capturing/comparing. The two specific working processes are as follows:

In capture mode, the capture is actually done in the shadow register, and then the value in the shadow register is copied into the preload register.

In compare mode, as opposed to capture mode, the value of the preload register is copied into the shadow register, which is compared with the counter.

### 11.3.6 Input capture mode

In capture mode, the TIMx\_CCxDATx registers are used to latch the counter value after the ICx signal detects.

There is a capture interrupt flag TIMx\_STS.CCxITF, which can issue an interrupt or DMA request if the corresponding interrupt enable is pulled high.

The TIMx\_STS.CCxITF bit is set by hardware when a capture event occurs and is cleared by software or by reading

the TIMx\_CCxDATx register.

The overcapture flag TIMx\_STS.CCxOCF is set equal to 1 when the counter value is captured in the TIMx\_CCxDATx register and TIMx\_STS.CCxITF is already pulled high. Unlike the former, TIMx\_STS.CCxOCF is cleared by writing 0 to it.

To achieve a rising edge of the TI1 input to capture the counter value into the TIMx\_CCxDAT1 register, the configuration flow is as follows:

- To select a valid input:

Configure TIMx\_CCMOD1.CC1SEL to '01'. At this time, the input is the CC1 channel, and IC1 is mapped to TI1.

- Program the desired input filter duration:

Define the sampling frequency of the TI1 input and the length of the digital filter by configuring the TIMx\_CCMODx.ICxF bits. Example: If the input signal jitters up to 5 internal clock cycles, we must choose a filter duration longer than these 5 clock cycles. When 8 consecutive samples (sampled at  $f_{DTS}$  frequency) with the new level are detected, we can validate the transition on TI1. Then configure TIMx\_CCMOD1.IC1F to '0011'.

- By configuring TIMx\_CCEN.CC1P=0, select the rising edge as the valid transition polarity on the TI1 channel.
- Configure the input prescaler. In this example, configure TIMx\_CCMOD1.IC1PSC= '00' to disable the prescaler because we want to capture every valid transition.
- Enable capture by configuring TIMx\_CCEN.CC1EN = '1'.

If you want to enable DMA request, you can configure TIMx\_DINTEN.CC1DEN=1. If you want enable related interrupt request, you can configure TIMx\_DINTEN.CC1IEN bit=1

### 11.3.7 PWM input mode

There are some differences between PWM input mode and normal input capture mode, including:

- Two ICx signals are mapped to the same TIx input.
- The two ICx signals are active on edges of opposite polarity.
- Select one of two TIxFP signals as trigger input.
- The slave mode controller is configured in reset mode.

For example, the following configuration flow can be used to know the period and duty cycle of the PWM signal on TI1 (It depends on the frequency of CK\_INT and the value of the prescaler).

- Configure TIMx\_CCMOD1.CC1SEL equal to '01' to select TI1 as valid input for TIMx\_CCxDAT1.
- Configure TIMx\_CCEN.CC1P equal to '0' to select the active polarity of filtered timer input 1(TI1FP1), valid on the rising edge.
- Configure TIMx\_CCMOD1.CC2SEL equal to '10' select TI1 as valid input for TIMx\_CCxDAT2.
- Configure TIMx\_CCEN.CC2P equal to 1 to select the valid polarity of filtered timer input 2(TI1FP2), valid on the falling edge.

- Configure TIMx\_SMCTRL.TSEL=101 to select Filtered timer input 1 (TI1FP1) as valid trigger input.
- Configure TIMx\_SMCTRL.SMSEL=100 to configure the slave mode controller to reset mode.
- Configure TIMx\_CCEN. CC1EN=1 and TIMx\_CCEN.CC2EN=1 to enable capture.

Figure 11-20 PWM input mode timing

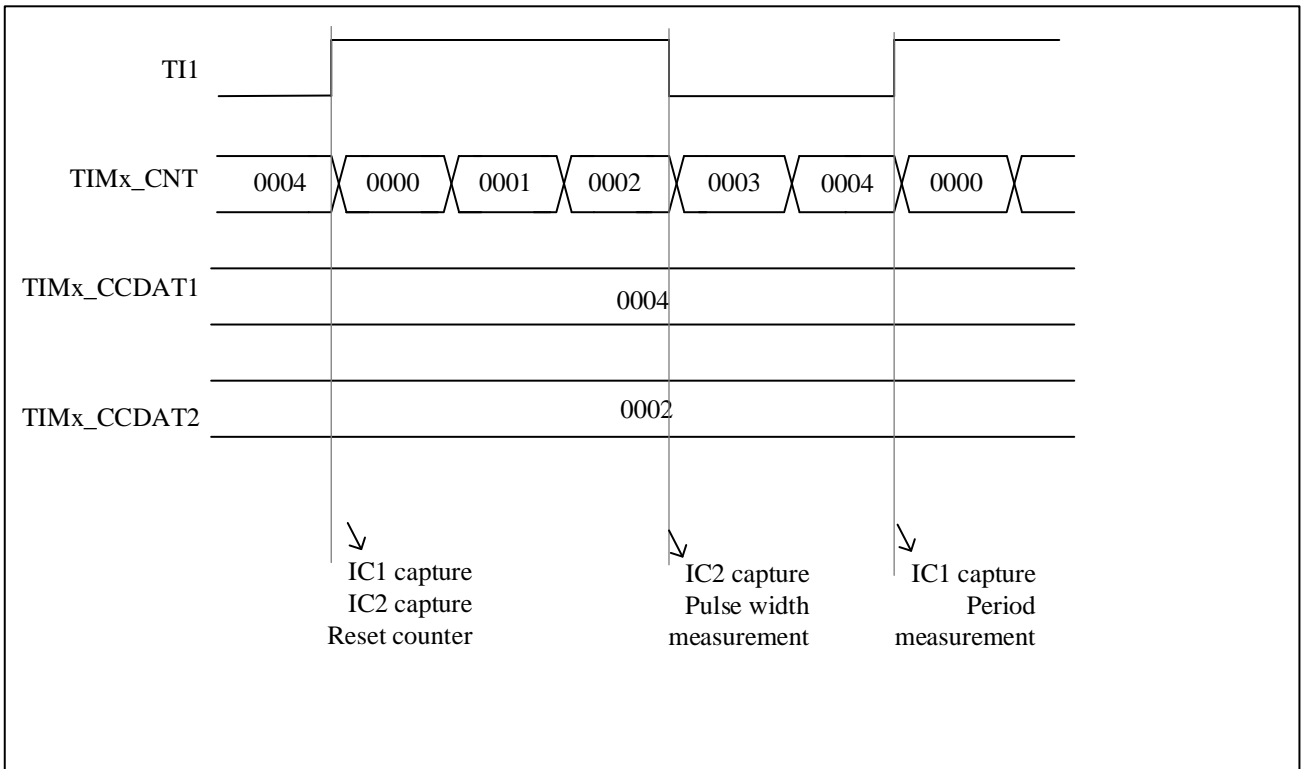

Because of only filter timer input 1 (TI1FP1) and filter timer input 2 (TI2FP2) are connected to the slave mode controller, the PWM input mode can only be used with the TIMx\_CH1/TIMx\_CH2 signals.

### 11.3.8 Forced output mode

Software can force output compare signals to active or inactive level directly, in output mode (TIMx\_CCMODx.CCxSEL=00).

User can set TIMx\_CCMODx. OCxMD=101 to force the output compare signal to active level. And the OCxREF will be forced high, OCx get opposite value to CCxP polarity bit. On the other hand, user can set TIMx\_CCMODx. OCxMD=100 to force the output compare signal to inactive level.

The values of the TIMx\_CCDATx shadow register and the counter still comparing with each other in this mode.

The comparison between the output compare register TIMx\_CCDATx and the counter TIMx\_CNT has no effect on OCxREF. And the flag still can be set. Therefore, the interrupt and DMA requests still can be sent.

### 11.3.9 Output compare mode

User can use this mode to control the output waveform, or to indicate that a period of time has elapsed.

When the capture/compare register and the counter have the same value, the output compare function's operations

are as follow:

- TIMx\_CCMODx.OCxMD is for output compare mode, and TIMx\_CCEN.CCxP is for output polarity. When the compare matches, if set TIMx\_CCMODx.OCxMD=000, the output pin will keep its level; if set TIMx\_CCMODx.OCxMD=001, the output pin will be set active; if set TIMx\_CCMODx.OCxMD=010, the output pin will be set inactive; if set TIMx\_CCMODx.OCxMD=011, the output pin will be set to toggle.
- Set TIMx\_STS.CCxITF.
- If user set TIMx\_DINTEN.CCxIEN, a corresponding interrupt will be generated.
- If user set TIMx\_DINTEN.CCxDEN and set TIMx\_CTRL2.CCDSEL to select DMA request, and DMA request will be sent.

User can set TIMx\_CCMODx.OCxPEN to choose capture/compare shadow register using capture/compare preload registers (TIMx\_CCxATx) or not.

The time resolution is one count of the counter.

In one-pulse mode, the output compare mode can also be used to output a single pulse.

Here are the configuration steps for output compare mode:

- First of all, user should select the counter clock.
- Secondly, set TIMx\_AR and TIMx\_CCxATx with desired data.
- If user need to generate an interrupt, set TIMx\_DINTEN.CCxIEN.
- Then select the output mode by set TIMx\_CCEN.CCxP, TIMx\_CCMODx.OCxMD, TIMx\_CCEN.CCxEN, etc.
- At last, set TIMx\_CTRL1.CNTEN to enable the counter.

User can update the output waveform by setting TIMx\_CCxATx at any time, as long as the preload register is not enabled. Otherwise the TIMx\_CCxATx shadow register will be updated at the next update event.

Here is an example.

Figure 11-21 Output compare mode, toggle on OC1

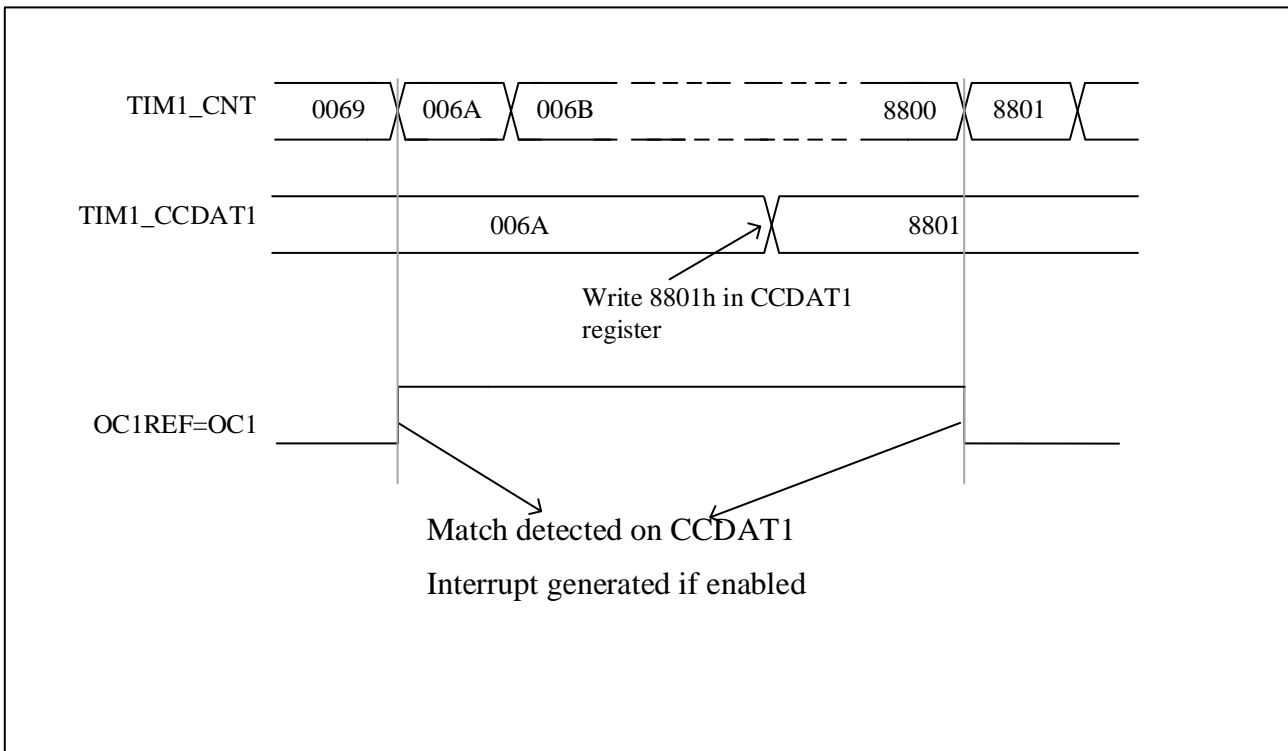

### 11.3.10 PWM mode

User can use PWM mode to generate a signal whose duty cycle is determined by the value of the **TIMx\_CC DATx** register and whose frequency is determined by the value of the **TIMx\_AR** register. And depends on the value of **TIMx\_CTRL1.CAMSEL**, the TIM can generate PWM signal in edge-aligned mode or center-aligned mode.

User can set PWM mode 1 or PWM mode 2 by setting **TIMx\_CCMODx**. **OCxMD=110** or setting **TIMx\_CCMODx**. **OCxMD=111**. To enable preload register, user must set corresponding **TIMx\_CCMODx.OCxPEN**. And then set **TIMx\_CTRL1.ARPEN** to auto-reload preload register eventually.

User can set polarity of **OCx** by setting **TIMx\_CCEN.CCxP**. On the other hand, to enable the output of **OCx**, user need to set the combination of the value of **CCxEN**, **CCxNEN**, **MOEN**, **OSSI**, and **OSSR** in **TIMx\_CCEN** and **TIMx\_BKDT**.

The values of **TIMx\_CNT** and **TIMx\_CC DATx** are always compared with each other when the TIM is under PWM mode.

Only if an update event occurs, the preload register will transfer to the shadow register. Therefore user must reset all the registers by setting **TIMx\_EVTGEN.UDGN** before the counter starts counting.

#### 11.3.10.1 PWM center-aligned mode

If user set **TIMx\_CTRL1.CAMSEL** equal 01, 10 or 11, the PWM center-aligned mode will be active. The setting of the compare flag depends on the value of **TIMx\_CTRL1.CAMSEL**. There are three kinds of situation that the compare flag is set, only when the counter counts up, only when the counter counts down, or when the counter counts up and counts down. User should not modified **TIMx\_CTRL1.DIR** by software, it is updated by hardware.

Examples of center-aligned PWM waveforms is as follow, and the setting of the waveform are: **TIMx\_AR=8**, PWM

mode 1, the compare flag is set when the counter counts down corresponding to TIMx\_CTRL1. CAMSEL=01.

Figure 11-22 Center-aligned PWM waveform (AR=8)

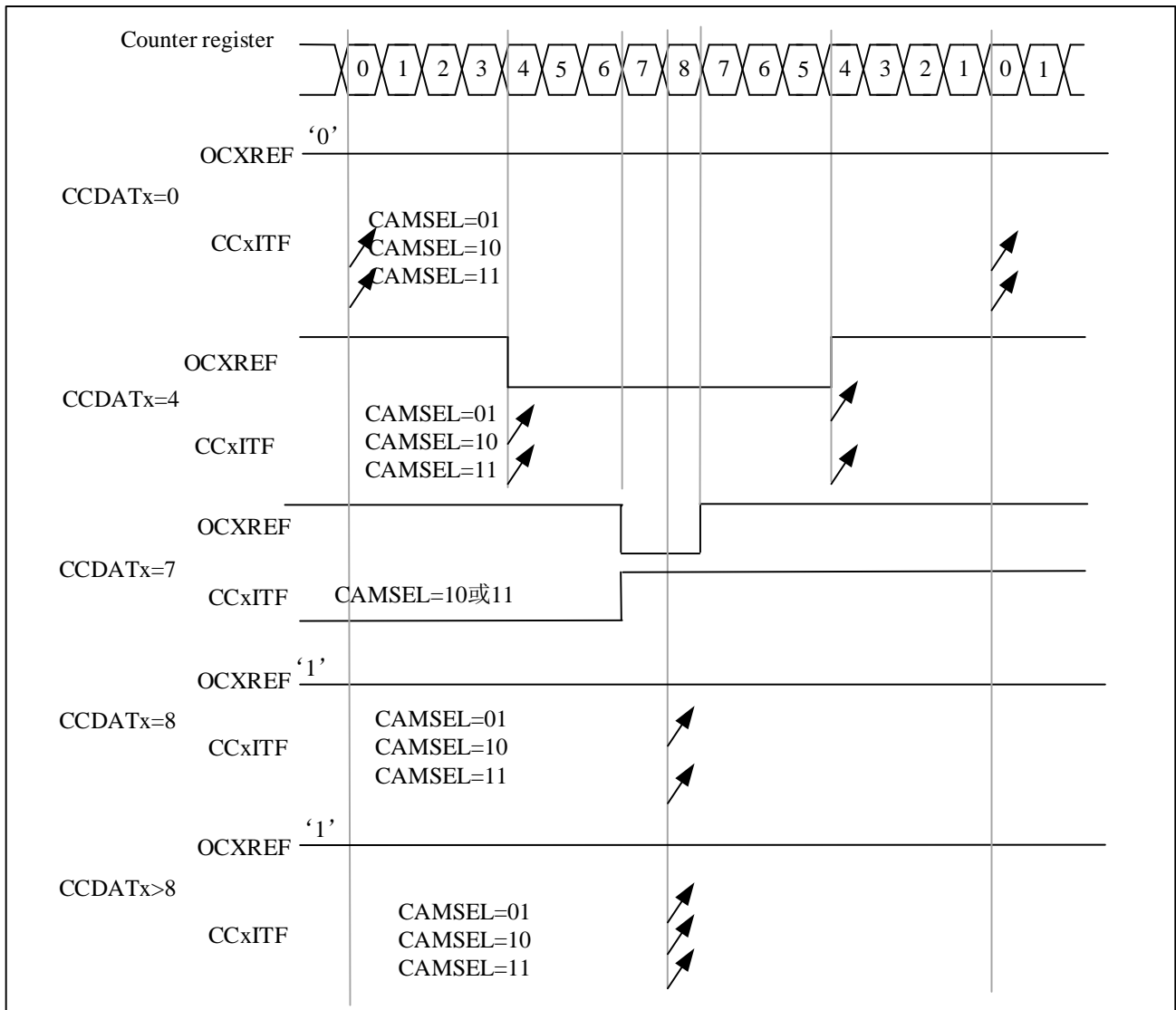

Notes that user should know when using center-aligned mode are as follow:

- It depends on the value of TIMx\_CTRL1.DIR that the counter counts up or down. Cautions that the DIR and CAMSEL bits should not be changed at the same time.
- User should not write the counter while running in center-aligned mode, otherwise it will cause unexpected results. Here are some example:
  - ◆ If the value written into the counter is 0 or is the value of TIMx\_AR, the direction will be updated but the update event will not be generated.
  - ◆ If the value written into the counter is greater than the value of auto-reload, the direction will not be updated.
- To be on the safe side, user is suggested setting TIMx\_EVTGEN.UDGN to generate an update by software

before starting the counter, and not writing the counter while it is running.

### 11.3.10.2 PWM edge-aligned mode

There are two kinds of configuration in edge-aligned mode, up-counting and down-counting.

- **Up-counting**

User can set `TIMx_CTRL1.DIR=0` to make counter counts up.

Here is an example for PWM mode1.

When  $TIMx\_CNT < TIMx\_CCDATx$ , the reference PWM signal `OCxREF` is high. Otherwise it will be low. If the compare value in `TIMx_CCDATx` is greater than the auto-reload value, the `OCxREF` will remains 1. Conversely, if the compare value is 0, the `OCxREF` will remains 0.

When `TIMx_AR=8`, the PWM waveforms are as follow.

Figure 11-23 Edge-aligned PWM waveform (APR=8)

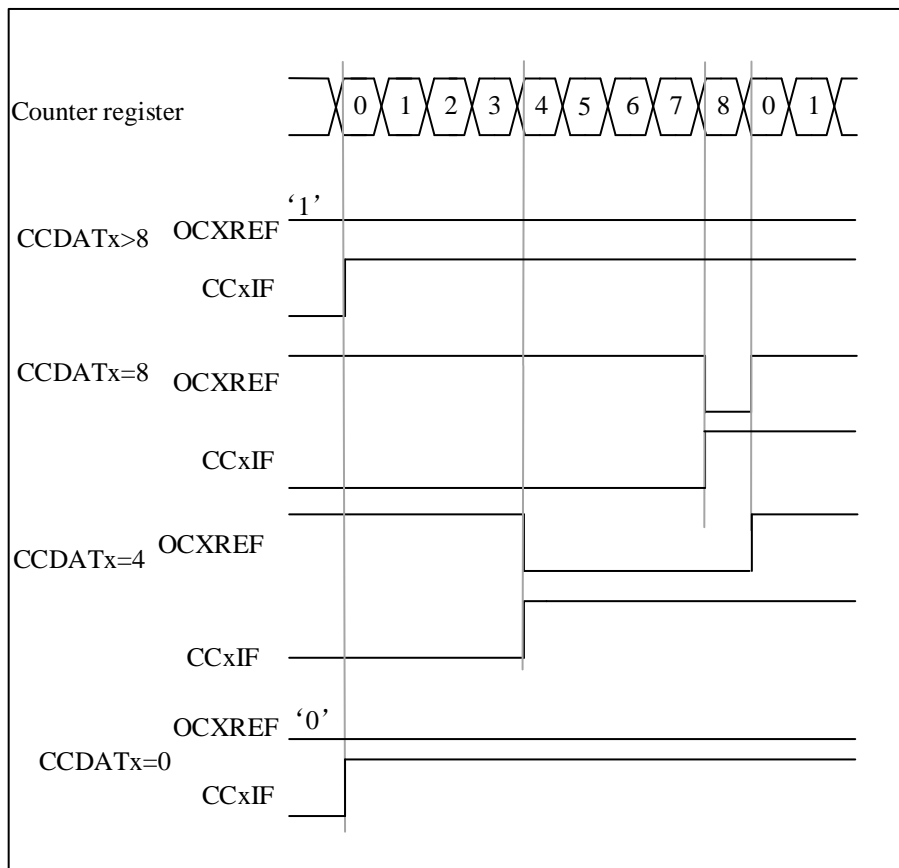

- **Down-counting**

User can set `TIMx_CTRL1.DIR=1` to make counter counts down.

Here is an example for PWM mode1.

When  $TIMx\_CNT > TIMx\_CCDATx$ , the reference PWM signal `OCxREF` is low. Otherwise it will be high. If the compare value in `TIMx_CCDATx` is greater than the auto-reload value, the `OCxREF` will remains 1.

*Note: If the  $n$ th PWM cycle `CCDATx` shadow register  $\geq$  `AR` value, the shadow register value of `CCDATx` in the  $(n+1)$ th PWM cycle is 0. At the moment when the counter is 0 in the  $(n+1)$ th PWM cycle, although the value of the*

counter = CCDATx shadow register = 0 and OCxREF = '0', no compare event will be generated.

### 11.3.11 One-pulse mode

In the one-pulse mode (ONEPM), a trigger signal is received, and a pulse  $t_{PULSE}$  with a controllable pulse width is generated after a controllable delay  $t_{DELAY}$ . The output mode needs to be configured as output compare mode or PWM mode. After selecting one-pulse mode, the counter will stop counting after the update event UEV is generated.

Figure 9-41 Example of One-pulse mode

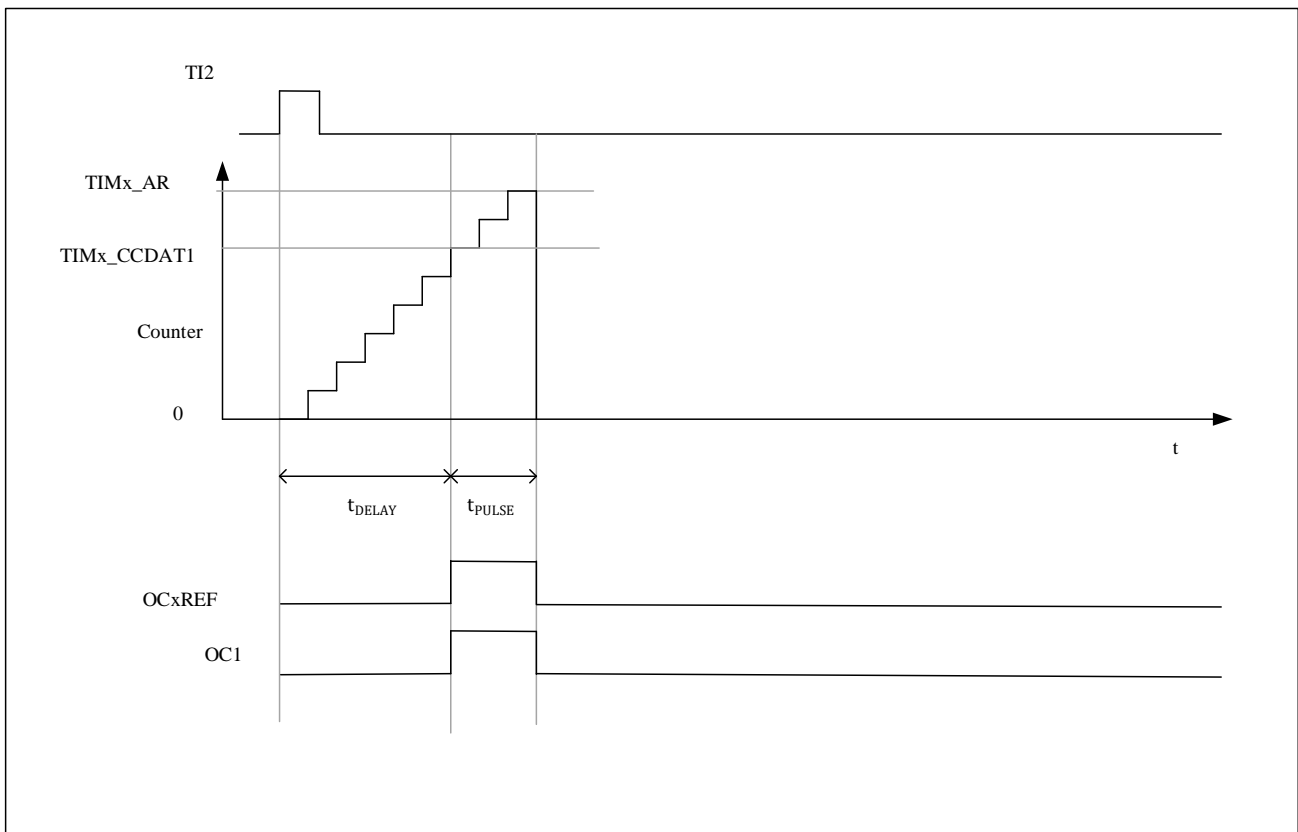

The following is an example of a one-pulse mode:

A rising edge trigger is detected from the TI2 input, and a pulse with a width of  $t_{PULSE}$  is generated on OC1 after a delay of  $t_{DELAY}$ .

1. Counter configuration: count up, counter  $TIMx\_CNT < TIMx\_CCDAT1 \leq TIMx\_AR$ ;
2. TI2FP2 is mapped to TI2,  $TIMx\_CCMOD1.CC2SEL = '01'$ ; TI2FP2 is configured for rising edge detection,  $TIMx\_CCEN.CC2P = '0'$ ;
3. TI2FP2 acts as the trigger (TRGI) of the slave mode controller and starts the counter,  $TIMx\_SMCTRL.TSEL = '110'$ ,  $TIMx\_SMCTRL.SMSEL = '110'$  (trigger mode);
4.  $TIMx\_CCDAT1$  writes the count value to be delayed ( $t_{DELAY}$ ),  $TIMx\_AR - TIMx\_CCDAT1$  is the count value of the pulse width  $t_{PULSE}$ ;
5. Configure  $TIMx\_CTRL1.ONEPM = 1$  to enable single pulse mode, configure  $TIMx\_CCMOD1.OC1MD = '111'$  to

select PWM2 mode;

6. Wait for an external trigger event on TI2, and a one pulse waveform will be output on OC1;

### 11.3.11.1 Special case: OCx fast enable:

In one-pulse mode, an edge is detected through the TIX input, and triggers the start of the counter to count to the comparison value and then output a pulse. These operations limit the minimum delay  $t_{DELAY}$  that can be achieved.

You can set `TIMx_CCMODx.OCxFEN=1` to turn on OCx fast enable, after triggering the rising edge, the OCxREF signal will be forced to be converted to the same level as the comparison match occurs immediately, regardless of the comparison result. OCxFEN fast enable only takes effect when the channel mode is configured for PWM1 and PWM2 modes.

### 11.3.12 Clearing the OCxREF signal on an external event

If user set `TIMx_CCMODx.OCxCEN=1`, high level of ETRF input can be used to driven the OCxREF signal to low, and the OCxREF signal will remains low, until the next UEV happens. Only output compare and PWM modes can use this function. This cannot be used when it is in forced mode.

Here is an example for it. To control the current, user can connect the ETR signal to the output of a comparator, and the operation for ETR should be as follow:

- Set `TIMx_SMCTRL.EXTPS=00` to disable the external trigger prescaler.
- Set `TIMx_SMCTRL.EXCEN=0` to disable the external clock mode 2.
- Set `TIMx_SMCTRL.EXTP` and `TIMx_SMCTRL.EXTF` to configure the external trigger polarity and external trigger filter according to the need.

Here is an example for the case that when ETRF input becomes high, the behavior of OCxREF signal for different value of OCxCEN. Timer is set to be in PWM mode in this case.

Figure 11-24 Clearing the OCxREF of TIMx

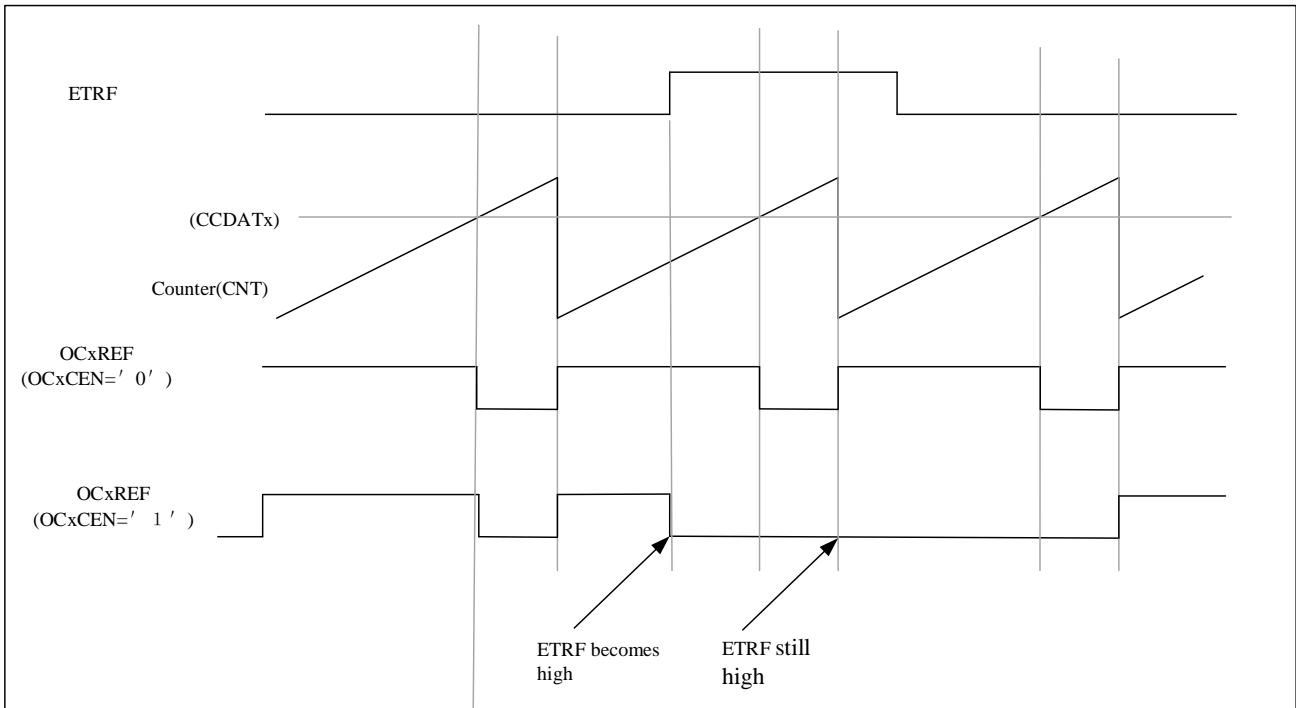

### 11.3.13 Complementary outputs with dead-time insertion

Advanced-control timer can output two complementary signals, and manage the switching-off and switching-on of outputs. This is called dead-time. User should adjust dead-time depending on the devices connected to the outputs and their characteristics.

User can select the polarity of outputs by setting `TIMx_CCEN.CCxP` and `TIMx_CCEN.CCxNP`. And this selection is independently for each output.

User can control the complementary signals `OCx` and `OCxN` by setting the combination of several control bits, which are `TIMx_CCEN.CCxEN`, `TIMx_CCEN.CCxNEN`, `TIMx_BKDT.MOEN`, `TIMx_CTRL2.OIx`, `TIMx_CTRL2.OIxN`, `TIMx_BKDT.OSSI`, and `TIMx_BKDT.OSSR`. When switching to the IDLE state, the dead-time will be activated.

If user set `TIMx_CCEN.CCxEN` and `TIMx_CCEN.CCxNEN` at the same time, a dead-time will be insert. If there is a break circuit, the `TIMx_BKDT.MOEN` should be set too. There are 10-bit dead-time generators for each channel.

Reference waveform `OCxREF` can generates 2 outputs `OCx` and `OCxN`. And if `OCx` and `OCxN` are active high, the `OCx` output signal is the same as the reference signal and the `OCxN` output signal is the opposite of the reference signal. However, `OCx` output signal will be delayed relative to the reference rising edge and the `OCxN` output signal will be delayed relative to the reference falling edge. If the delay is greater than the width of the active `OCx` or `OCxN` output, the corresponding pulse will not generated.

The relationships between the output signals of the dead-time generator and the reference signal `OCxREF` are as follow.

Assume that `TIMx_CCEN.CCxP=0`, `TIMx_CCEN.CCxNP=0`, `TIMx_BKDT.MOEN=1`, `TIMx_CCEN.CCxEN=1`, `TIMx_CCEN.CCxNEN=1`.

Figure 11-25 Complementary output with dead-time insertion

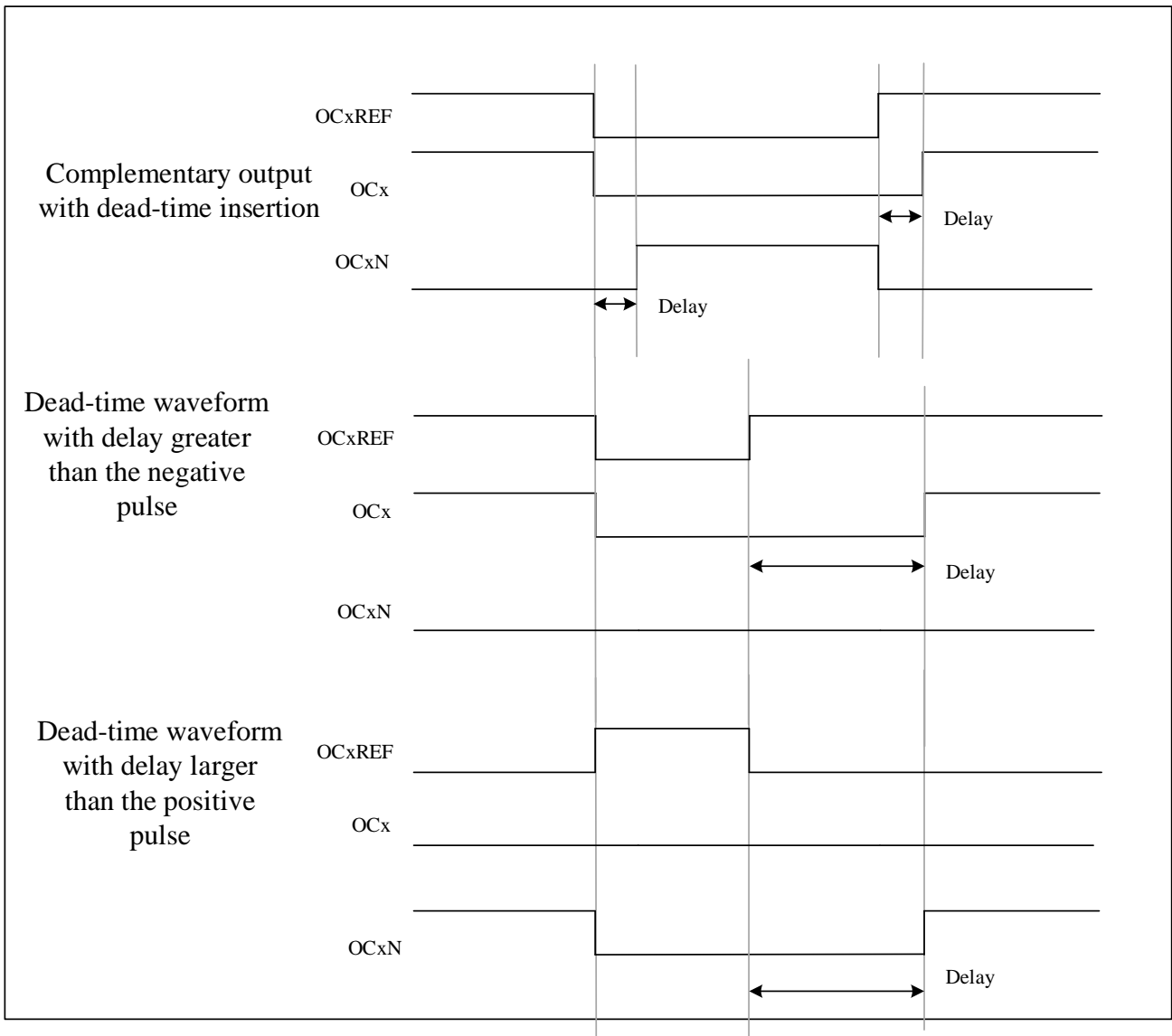

User can set TIMx\_BKDT.DTGN to programme the dead-time delay for each of the channels.

### 11.3.13.1 Redirecting OCxREF to OCx or OCxN

User can set TIMx\_CCEN.CCxEN and TIMx\_CCEN.CCxNEN to re-directed OCxREF to the OCx output or to OCxN output, in output mode.

Here are two ways to use this function. When the complementary remains at its inactive level, user can use this function to send a specific waveform, such as PWM or static active level. User can also use this function to set both outputs in their inactive level or both outputs active and complementary with dead-time.

If user set TIMx\_CCEN.CCxEN=0 and TIMx\_CCEN.CCxNEN=1, it will not complemented, and OCxN will become active when OCxREF is high. On the other hand, if user set TIMx\_CCEN.CCxEN=1 and TIMx\_CCEN.CCxNEN=1, OCx will become active when OCxREF is high. On the contrary, OCxN will become active when OCxREF is low.

### 11.3.14 Break function

The output enable signals and inactive levels will be modified when setting the corresponding control bits when using the break function. However, the output of OCx and OCxN cannot at the active level at the same time no matter when, that is,  $(CCxP \wedge OIx) \wedge (CCxNP \wedge OIxN) \neq 0$ .

When multiple break signals are enabled, each break signal constitutes an OR logic. Here are some signal which can be the source of breaking.

- The break input pin
- A clock failure event, generated by the clock security system in the clock controller.
- A PVD failure event.
- Core Hardfault event.
- The output signal of the comparator (configured in the comparator module, high level break).
- By software through the TIMx\_EVTGEN.BGN.

The break circuit will be disable after reset. And the MOEN bit will be low. User can set TIMx\_BKDT.BKEN to enable the break function. The polarity of break input signal can be selected by setting TIMx\_BKDT.BKP. User can modify the TIMx\_BKDT.BKEN and TIMx\_BKDT.BKP at the same time. After user set the TIMx\_BKDT.BKEN and TIMx\_BKDT.BKP, there is 1 APB clock cycle delay before the option take effect. Therefore, user need to wait 1 APB clock cycle to read back the value of the written bit.

The falling edge of MOEN can be asynchronous, so between the actual signal and the synchronous control bit, there set a resynchronization circuit. This circuit will cause a delay between the asynchronous and the synchronous signal. When user set TIMx\_BKDT.MOEN while it is low, user need to insert a delay before reading the value. Because an asynchronous signal was written but user read the synchronous signal.

The behaviors that after a break occurs are as follow:

- TIMx\_BKDT.MOEN will be cleared asynchronously, and then the outputs will be put in inactive state, idle state or reset state. The state of output is selected by setting TIMx\_BKDT.OSSI. This will take effect even if the MCU oscillator is off.
- Once TIMx\_BKDT.MOEN=0, the output of each output channel will be driven with the level programmed in TIMx\_CTRL2.OIx. Timer will release the enable outputs(taken over by GPIO controller) if TIMx\_BKDT.OSSI=0, otherwise it will remains high.
- If user choose to use complementary outputs, the behaviors of TIM are as follow
  - ◆ Depends on the polarity, the outputs will be set in reset state first. It is an asynchronous option so it still works even if there is no clock provided to the timer.
  - ◆ The dead-time generator will reactivated if the timer clock is still provided, and drive the outputs according to the value of TIMx\_CTRL2.OIx and TIMx\_CTRL2.OIxN after the dead-time when  $(CCxP \wedge OIx) \wedge (CCxNP \wedge OIxN) \neq 0$ , that is, the OCx and OCxN still cannot be driven to active level at the same time. Note that the dead-time will be longer than usual because of the resynchronization on MOEN (almost 2 cycles of ck\_tim).
  - ◆ Timer will release the output control if TIMx\_BKDT.OSSI=0. Otherwise, if the enable output was high, it

will remain high. If it was low, it will become high when TIMx\_CCEN.CCxEN or TIMx\_CCEN.CCxNEN is high.

- If TIMx\_DINTEN.BIEN=1, when TIMx\_STS.BITF=1, an interrupt will be generated.
- If user set TIMx\_BKDT.AOEN, the TIMx\_BKDT.MOEN will be set automatically when the next UEV happened. User can use this to regulate. If user did not set TIMx\_BKDT.AOEN, the TIMx\_BKDT.MOEN will remain low until been set 1 again. At this situation, user can use this for security. User can connect the break input to thermal sensors, alarm for power drivers, or other security components.
- When the break input is active, TIMx\_BKDT.MOEN cannot be set automatically or by software at the same time, and the TIMx\_STS.BITF cannot be cleared. Because the break inputs are active on level.

To insure the security of application, the break circuit has the write protection function, and there is break input and output management too. It allow user to freeze some parameters, such as dead-time duration, OCx/OCxN polarities and state when disabled, OCxMD configurations, break enable and polarity. User can choose one of the 3 levels of protection to use by setting TIMx\_BKDT.LCKCFG. However, the TIMx\_BKDT.LCKCFG can only be written once after an MCU reset.

An example for output behavior in response to a break is as follow

Figure 11-26 Output behavior in response to a break

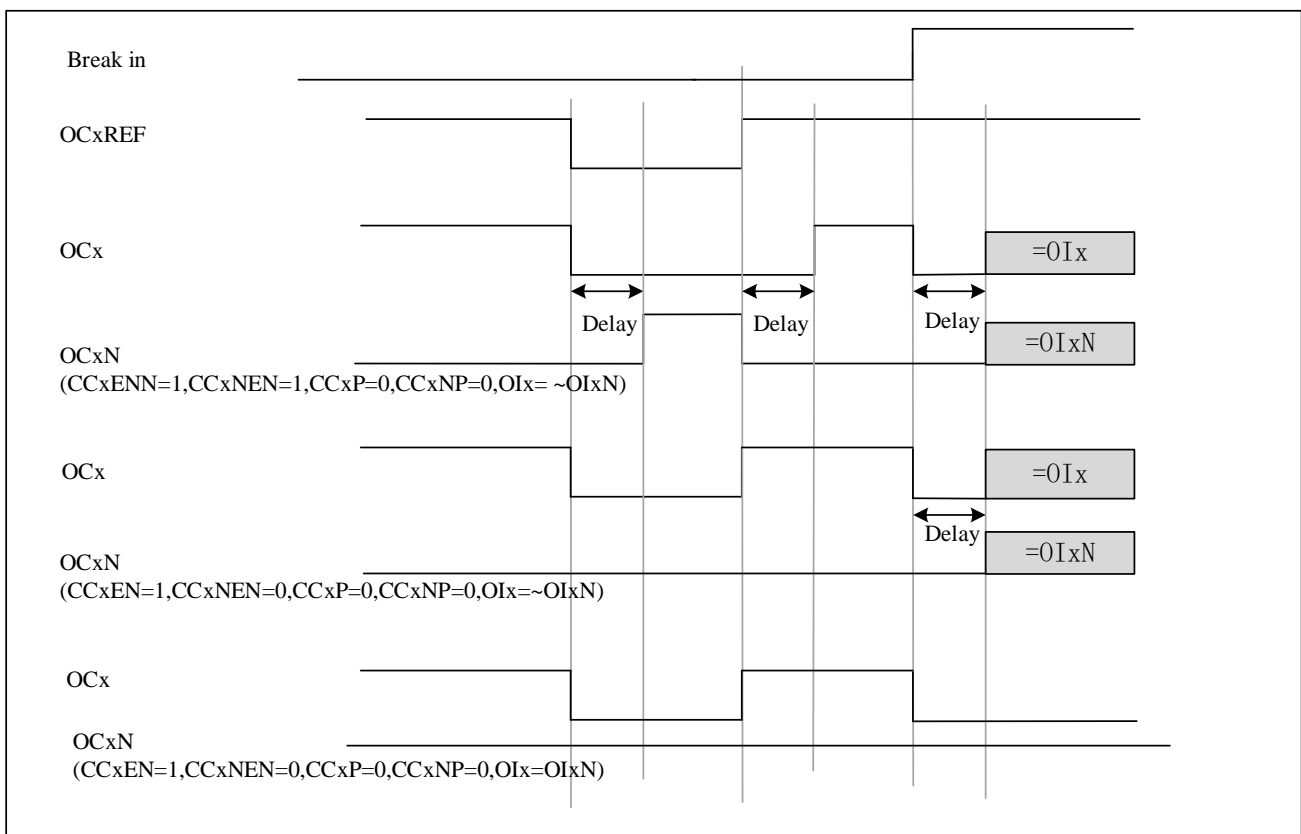

### 11.3.15 Debug mode

When the microcontroller is in debug mode (the Cortex-M4 core halted), depending on the DBG\_CTRL.TIMx\_STOP configuration in the DBG module, the TIMx counter can either continue to work normally or stop. For more details,

see 29.4.3.

### 11.3.16 TIMx and external trigger synchronization

TIMx timers can be synchronized by a trigger in slave modes (reset, trigger and gated).

#### 11.3.16.1 Slave mode: Reset mode

In reset mode, the trigger event can reset the counter and the prescaler updates the preload registers TIMx\_AR, TIMx\_CCDATx, and generates the update event UEV (TIMx\_CTRL1.UPRS=0).

The following is an example of a reset mode:

1. Channel 1 is configured as input to detect the rising edge of TI1 (TIMx\_CCMOD1.CC1SEL=01, TIMx\_CCEN.CC1P=0);
2. The slave mode is selected as reset mode (TIMx\_SMCTRL.SMSEL=100), and the trigger input is selected as TI1 (TIMx\_SMCTRL.TSEL=101);
3. Start counter (TIMx\_CTRL1.CNTEN = 1)

After starting the timer, when TI1 detects a rising edge, the counter resets and restarts counting, and the trigger flag is set (TIMx\_STS.TITF=1);

The delay between the rising edge on TI1 and the actual reset of the counter is due to the resynchronization circuit on TI1 input.

Figure 11-27 Control circuit in reset mode

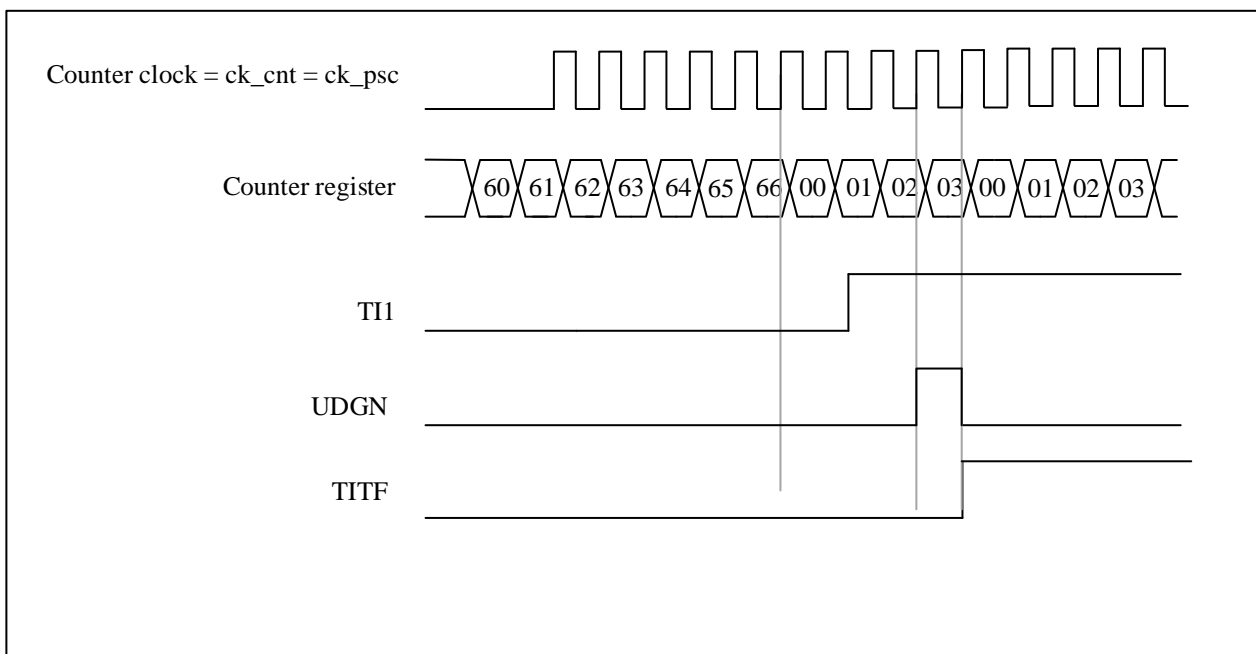

#### 11.3.16.2 Slave mode: Trigger mode

In trigger mode, the trigger event (rising edge/falling edge) of the input port can trigger the counter to start counting.

The following is an example of a trigger pattern:

1. Channel 2 is configured as input to detect the rising edge of TI2 (TIMx\_CCMOD1.CC2SEL=01,

TIMx\_CCEN.CC2P=0);

2. Select from mode to trigger mode (TIMx\_SMCTRL.SMSEL=110), select TI2 for trigger input (TIMx\_SMCTRL.TSEL=110);

When TI2 detects a rising edge, the counter starts counting, and the trigger flag is set (TIMx\_STS.TITF=1);

The delay between the rising edge on TI2 and the actual start of the counter is due to the resynchronization circuit on TI2 input.

Figure 11-28 Control circuit in Trigger mode

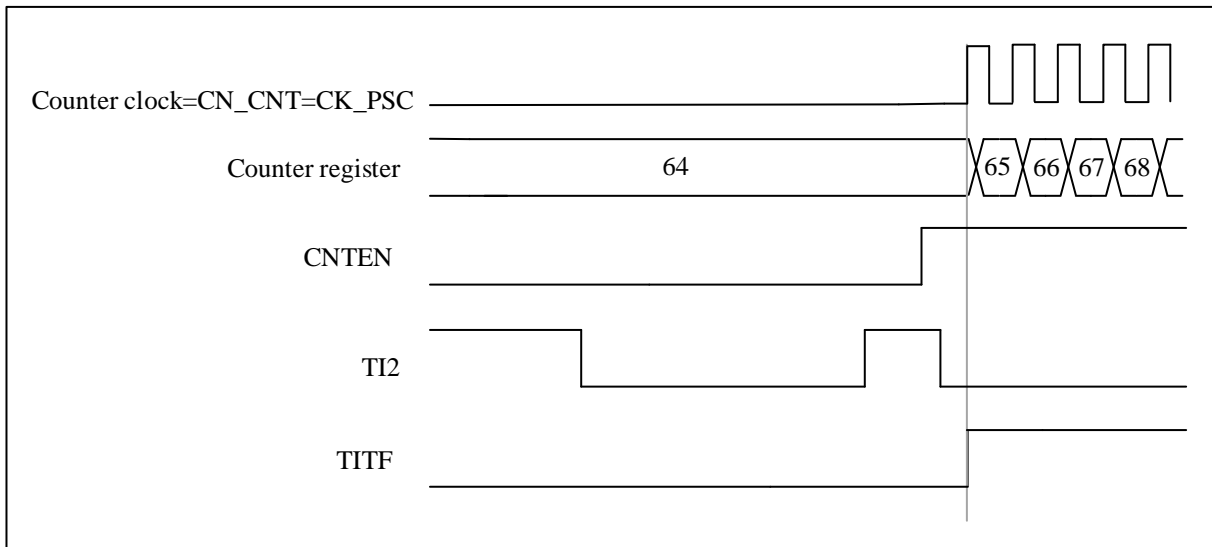

### 11.3.16.3 Slave mode: Gated mode

In gate control mode, the level polarity of the input port can control whether the counter counts.

The following is an example of a gated pattern:

1. Channel 1 is configured as input detection active low on TI1 (TIMx\_CCMOD1.CC1SEL=01, TIMx\_CCEN.CC1P=1);
2. Select the slave mode as the gated mode (TIMx\_SMCTRL.SMSEL=101), and select TI1 as the trigger input (TIMx\_SMCTRL.TSEL=101);
3. Start counter (TIMx\_CTRL1.CNTEN = 1)

When TI1 detects that the level changes from low to high, the counter stops counting, and when TI1 detects that the level changes from high to low, the counter starts counting, and the trigger flag will be set when it starts or stops counting (TIMx\_STS.TITF=1);

The delay between the rising edge on TI1 and the actual stop of the counter is due to the resynchronization circuit on TI1 input.

Figure 11-29 Control circuit in Gated mode

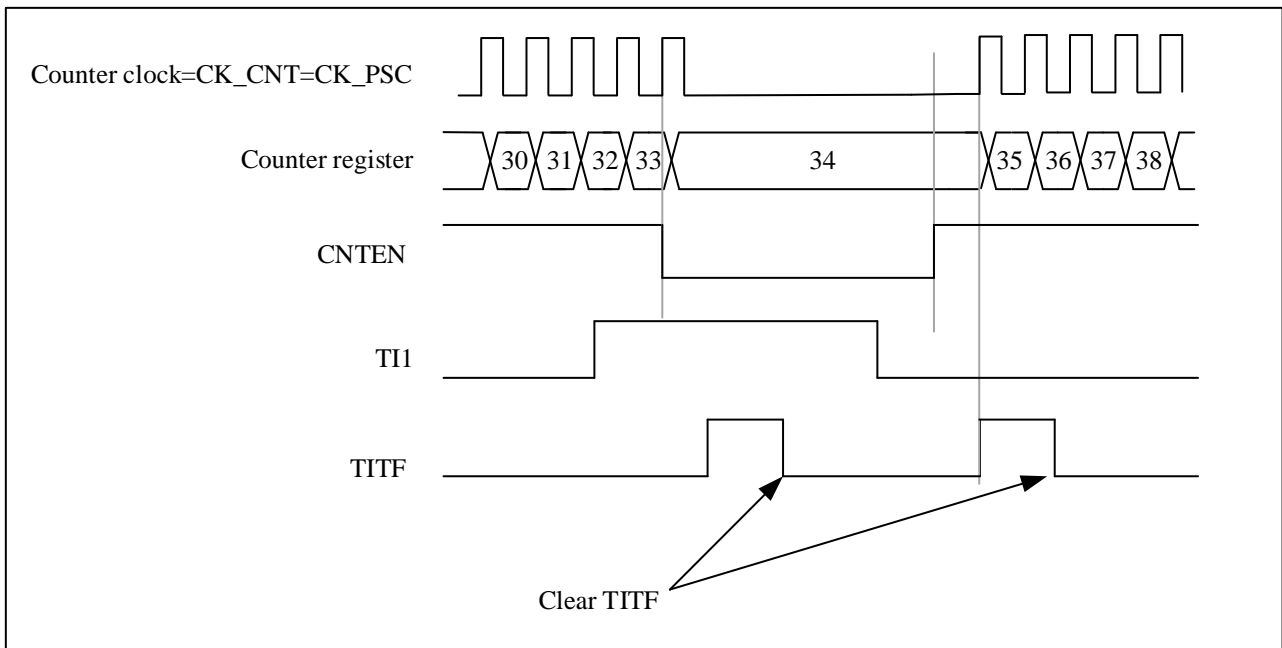

#### 11.3.16.4 Slave mode: Trigger Mode + External Clock Mode 2

In reset mode, trigger mode and gate control mode, the counter clock can be selected as external clock mode 2, and the ETR signal is used as the external clock source input. At this time, the trigger selection needs to select non-ETRF ( $TIMx\_SMCTRL.TSEL=111$ ).

Here is an example:

1. Channel 1 is configured as input to detect the rising edge of TI1 ( $TIMx\_CCMOD1.CC1SEL=01$ ,  $TIMx\_CCEN.CC1P=0$ );
2. Enable external clock mode 2 ( $TIMx\_SMCTRL.EXCEN=1$ ), select rising edge for external trigger polarity ( $TIMx\_SMCTRL.EXTP=0$ ), select slave mode as trigger mode ( $TIMx\_SMCTRL.SMSEL=110$ ), select TI1 for trigger input ( $TIMx\_SMCTRL.TSEL=101$ );

When TI1 detects a rising edge, the counter starts counting on the rising edge of ETR, and the trigger flag is set ( $TIMx\_STS.TITF=1$ );

Figure 11-30 Control circuit in Trigger Mode + External Clock Mode2

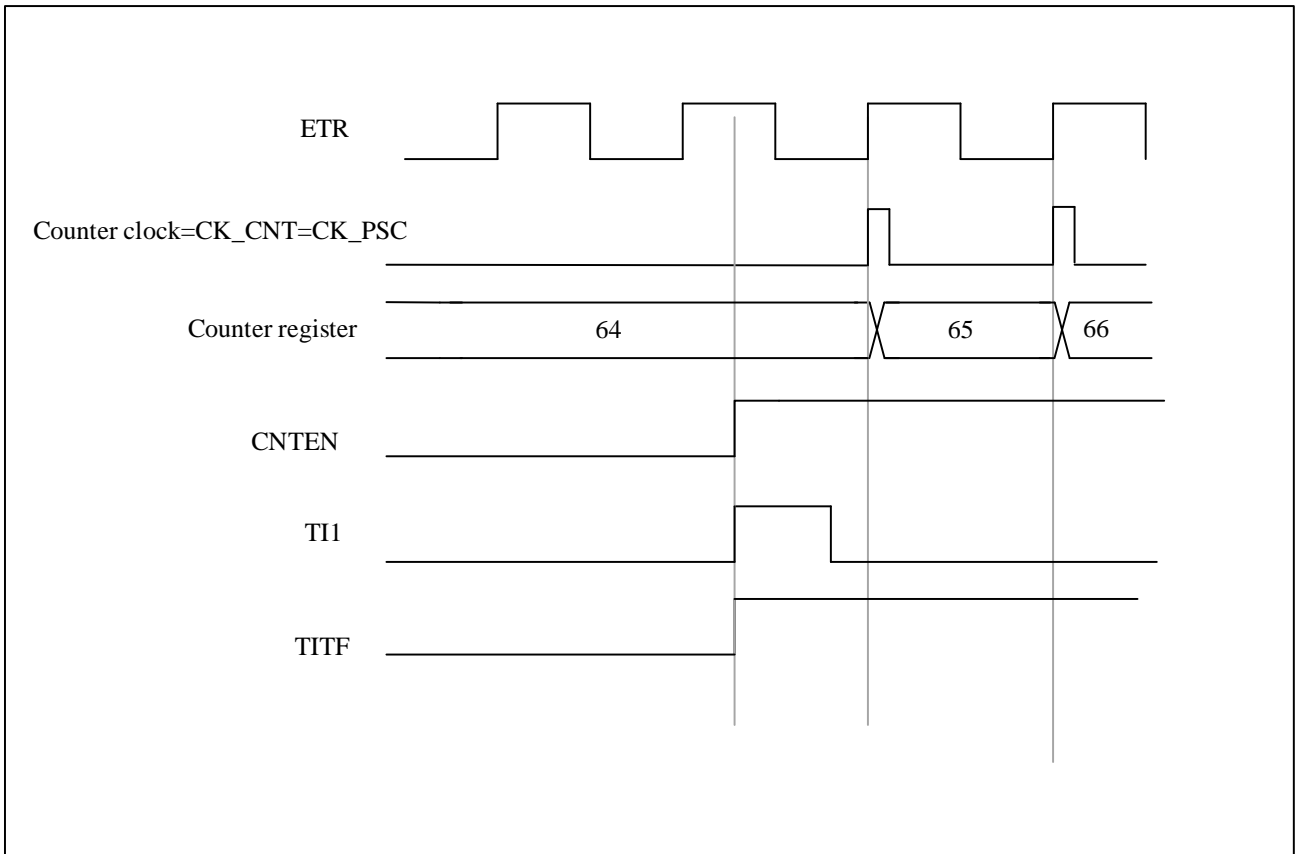

### 11.3.17 Timer synchronization

All TIM timers are internally connected for timer synchronization or chaining. For more details, see 12.3.14.

### 11.3.18 6-step PWM generation

In order to modify the configuration of all channels at the same time, the configuration of the next step can be set in advance (the preloaded bits are OCxMD, CCxEN and CCxNEN). When a COM commutation event occurs, the OCxMD, CCxEN, and CCxNEN preload bits are transferred to the shadow register bits.

COM commutation event generation method:

1. The software sets TIMx\_EVTGEN.CCUDGN;
2. Generated by hardware on the rising edge of TRGI;

When a COM commutation event occurs, the TIMx\_STS.COMITF flag will be set, enabling interrupts (TIMx\_DINTEN.COMIEN) will generate interrupts, and enabling DMA requests (TIMx\_DINTEN.COMDEN) will generate DMA requests.

The following figure shows the output timing diagram of OCx and OCxN when a COM commutation event occurs in three different configurations:

Figure 11-31 6-step PWM generation, COM example (OSSR=1)

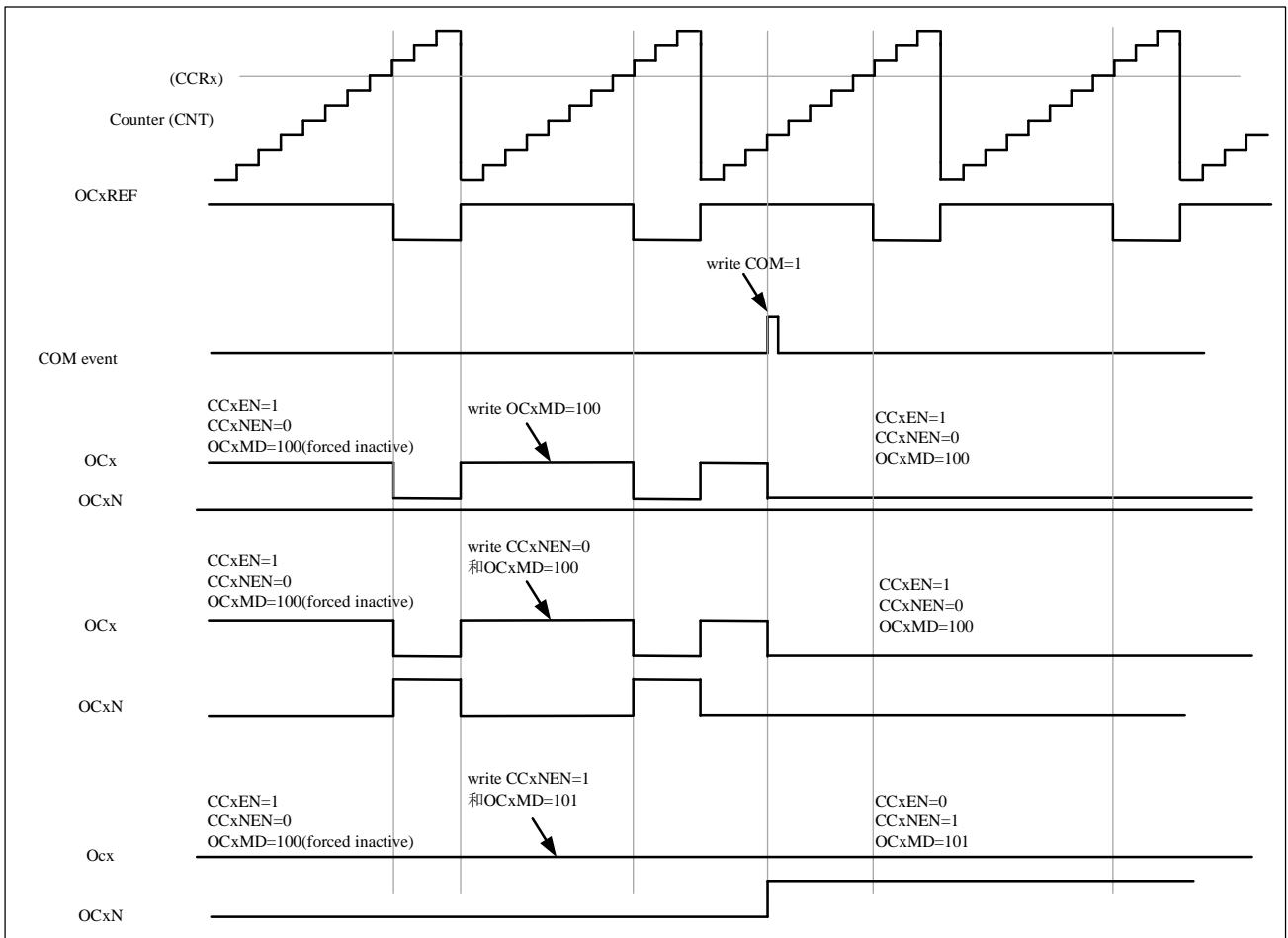

### 11.3.19 Encoder interface mode

The encoder uses two inputs TI1 and TI2 as an interface and the counter counts on every edge change on TI1FP1 or TI2FP2. The counting direction is automatically controlled by hardware TIMx\_CTRL1.DIR. There are three types of encoder counting modes:

1. The counter only counts on the edge of TI1, TIMx\_SMCTRL.SMSEL = '001';
2. The counter only counts on the edge of TI2, TIMx\_SMCTRL.SMSEL = '010';
3. The counter counts on the edges of TI1 and TI2 at the same time, TIMx\_SMCTRL.SMSEL = '011';

The encoder interface is equivalent to using an external clock with direction selection, and the counter only counts continuously between 0 and the auto-reload value (TIMx\_AR.AR [15:0]). Therefore, it is necessary to configure the auto-reload register TIMx\_AR in advance.

*Note: Encoder mode and external clock mode 2 are not compatible and must not be selected together.*

The relationship between the counting direction and the encoder signal is shown in **Table 11-1 Counting direction versus encoder signals**:

Table 11-1 Counting direction versus encoder signals

|  | Level on opposite signals | TI1FP1 signal | TI2FP2 signal |
|--|---------------------------|---------------|---------------|
|--|---------------------------|---------------|---------------|

| Active edge                | (TI1FP1 for TI2,<br>TI2FP2 for TI1) | Rising        | Falling       | Rising        | Falling       |
|----------------------------|-------------------------------------|---------------|---------------|---------------|---------------|
| Counting only at TI1       | High                                | Counting down | Counting up   | Don't count   | Don't count   |
|                            | Low                                 | Counting up   | Counting down | Don't count   | Don't count   |
| Counting only at TI2       | High                                | Don't count   | Don't count   | Counting up   | Counting down |
|                            | Low                                 | Don't count   | Don't count   | Counting down | Counting up   |
| Counting on<br>TI1 and TI2 | High                                | Counting down | Counting up   | Counting up   | Counting down |
|                            | Low                                 | Counting up   | Counting down | Counting down | Counting up   |

Here is an example of an encoder with dual edge triggering selected to suppress input jitter:

1. IC1FP1 is mapped to TI1 (TIMx\_CCMOD1.CC1SEL= '01'), IC1FP1 is not inverted (TIMx\_CCEN.CC1P= '0');
2. IC1FP2 is mapped to TI2 (TIMx\_CCMOD2.CC2SEL= '01'), IC2FP2 is not inverted (TIMx\_CCEN.CC2P= '0');
3. The input is valid on both rising and falling edges (TIMx\_SMCTRL.SMSEL = '011');
4. Enable counter TIMx\_CTRL1.CNTEN= '1';

Figure 11-32 Example of counter operation in encoder interface mode

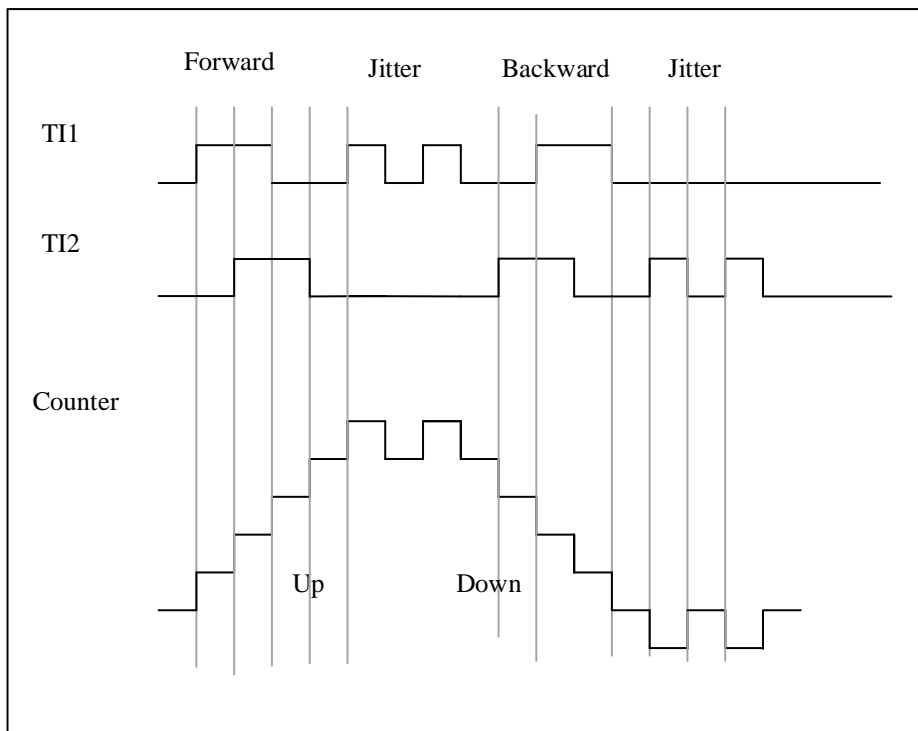

The following figure shows the example of counter behavior when IC1FP1 polarity is inverted (CC1P= '1', other configurations are the same as above)

Figure 11-33 Encoder interface mode example with IC1FP1 polarity inverted

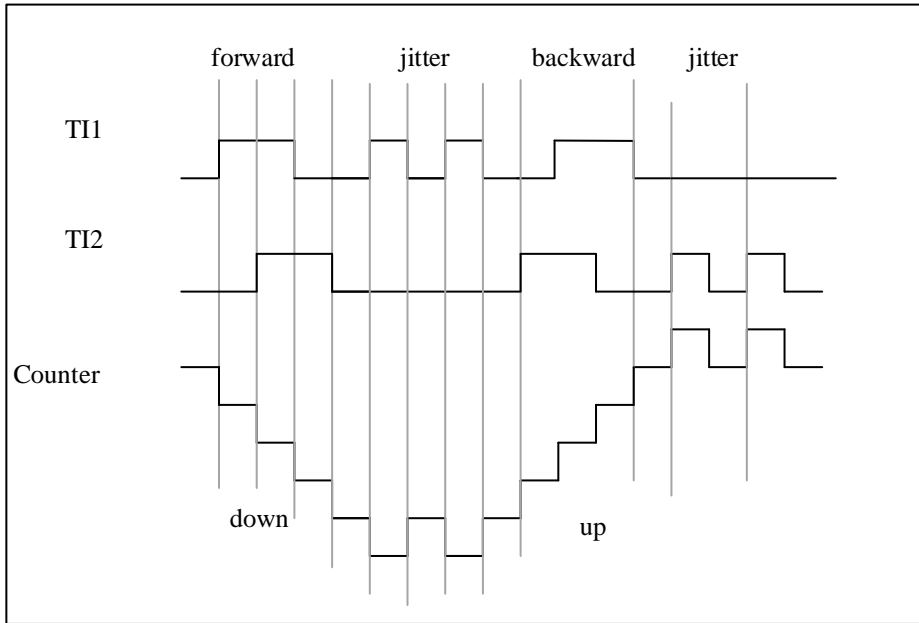

### 11.3.20 Interfacing with Hall sensor

Connect the Hall sensor to the three input pins (CC1, CC2 and CC3) of the timer, and then select the XOR function to pass the inputs of TIMx\_CH1, TIMx\_CH2 and TIMx\_CH3 through the XOR gate as the output of TI1 to channel 1 for capture signal.

The timer needs to be configured as the reset mode in slave mode (TIMx\_SMCTRL.SMSEL= '100'); the edge of the trigger select TI1 triggers TI1F\_ED (TIMx\_SMCTRL.TSEL= '100'), any change in the Hall 3 inputs will trigger the counter to recount, so it is used as a time reference; the capture/compare channel 1 is configured to capture the TRC signal in capture mode (TIMx\_CCMOD1.CC1SEL= '11'), which is used to calculate the two input time intervals, thereby reflecting the motor speed.

Select timer channel 2 to output pulses to the advanced timer to trigger the COM event of the advanced timer to update the control bits of the output PWM. The trigger selection of the advanced timer needs to select the corresponding internal trigger signal (TIMx\_SMCTRL.TSEL="ITRx"), the capture/compare preload control bit needs to be configured to support preload (TIMx\_CTRL2.CCPCTL=1) and support the rising edge of TRGI Trigger an update (TIMx\_CTRL2.CCUSEL=1).

This example is shown in the following figure.

Figure 11-34 Example of Hall sensor interface

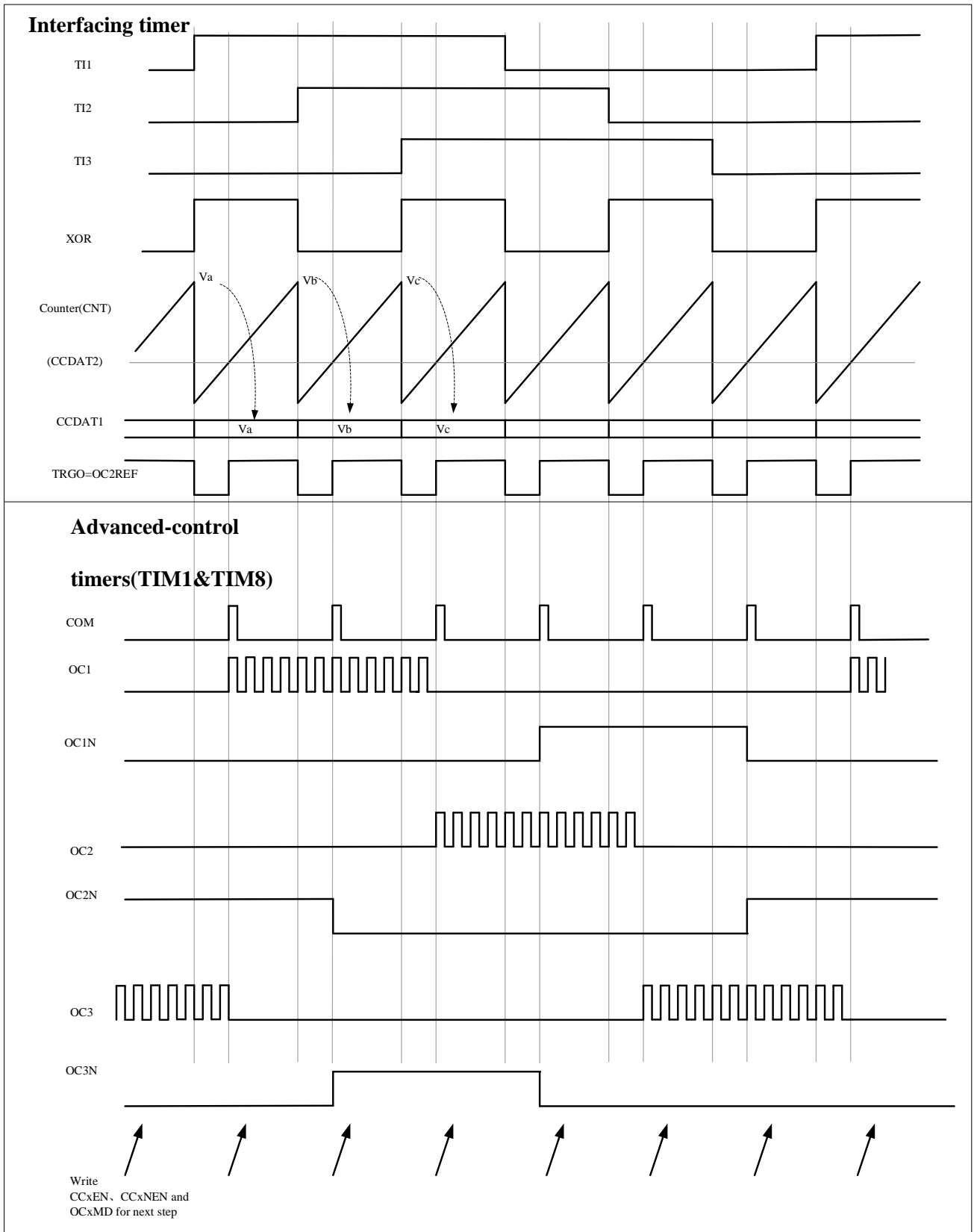

## 11.4 TIMx register (x=1, 8)

For abbreviations used in registers, see section 1.1.

These peripheral registers can be operated as half word (16-bits) or one word (32-bits).

### 11.4.1 Register Overview

Table 11-2 Register map and reset value

| Offset | Register    | 31       | 30 | 29 | 28 | 27 | 26 | 25 | 24 | 23 | 22 | 21 | 20 | 19 | 18 | 17        | 16          | 15          | 14        | 13          | 12          | 11         | 10          | 9         | 8           | 7           | 6      | 5      | 4           | 3      | 2      | 1        | 0      |      |       |   |   |   |   |   |
|--------|-------------|----------|----|----|----|----|----|----|----|----|----|----|----|----|----|-----------|-------------|-------------|-----------|-------------|-------------|------------|-------------|-----------|-------------|-------------|--------|--------|-------------|--------|--------|----------|--------|------|-------|---|---|---|---|---|
| 000h   | TIMx_CTRL1  | Reserved |    |    |    |    |    |    |    |    |    |    |    |    |    | PBKPEN    | LBPEN       | CLRSEL      | Reserved  | Reserved    | Reserved    | CISEL      | 10MBKPEN    | CLKD[1:0] | ARPEN       | CAMSEL[1:0] | DIR    | ONEPM  | UPRS        | UPDIS  | CNTEN  |          |        |      |       |   |   |   |   |   |
|        | Reset Value | 0        |    |    |    |    |    |    |    |    |    |    |    |    |    | 0         | 0           | 0           | 0         | 0           | 0           | 0          | 0           | 0         | 0           | 0           | 0      | 0      | 0           | 0      | 0      | 0        | 0      | 0    | 0     | 0 | 0 | 0 | 0 | 0 |
| 004h   | TIMx_CTRL2  | Reserved |    |    |    |    |    |    |    |    |    |    |    |    |    | Reserved  | O16         | Reserved    | O15       | Reserved    | O14         | O13N       | O13         | O12N      | O12         | O11N        | O11    | TI1SEL | MMSEL1[2:0] | CC2SEL | CC1SEL | Reserved | CCPCTL |      |       |   |   |   |   |   |
|        | Reset Value | 0        |    |    |    |    |    |    |    |    |    |    |    |    |    | 0         | 0           | 0           | 0         | 0           | 0           | 0          | 0           | 0         | 0           | 0           | 0      | 0      | 0           | 0      | 0      | 0        | 0      | 0    | 0     | 0 | 0 | 0 | 0 | 0 |
| 008h   | TIMx_SMCTRL | Reserved |    |    |    |    |    |    |    |    |    |    |    |    |    | EXTP      | EXCEN       | EXTPS[1:0]  | EXTF[3:0] | MSMD        | TSEL[2:0]   | Reserved   | SMSEL1[2:0] |           |             |             |        |        |             |        |        |          |        |      |       |   |   |   |   |   |
|        | Reset Value | 0        |    |    |    |    |    |    |    |    |    |    |    |    |    | 0         | 0           | 0           | 0         | 0           | 0           | 0          | 0           | 0         | 0           | 0           | 0      | 0      | 0           |        |        |          |        |      |       |   |   |   |   |   |
| 00Ch   | TIMx_DINTEN | Reserved |    |    |    |    |    |    |    |    |    |    |    |    |    | IDEN      | COMDEN      | CC4DEN      | CC3DEN    | CC2DEN      | CC1DEN      | UDEN       | BIEN        | TIEN      | COMIEN      | CC4IEN      | CC3IEN | CC2IEN | CC1IEN      | UIEN   |        |          |        |      |       |   |   |   |   |   |
|        | Reset Value | 0        |    |    |    |    |    |    |    |    |    |    |    |    |    | 0         | 0           | 0           | 0         | 0           | 0           | 0          | 0           | 0         | 0           | 0           | 0      | 0      | 0           | 0      | 0      | 0        | 0      |      |       |   |   |   |   |   |
| 010h   | TIMx_STS    | Reserved |    |    |    |    |    |    |    |    |    |    |    |    |    | CC6ITF    | CC5ITF      | Reserved    | CC4OCF    | CC3OCF      | CC2OCF      | CC1OCF     | Reserved    | BITF      | TITF        | COMITF      | CC4ITF | CC3ITF | CC2ITF      | CC1ITF | UDITF  |          |        |      |       |   |   |   |   |   |
|        | Reset Value | 0        |    |    |    |    |    |    |    |    |    |    |    |    |    | 0         | 0           | 0           | 0         | 0           | 0           | 0          | 0           | 0         | 0           | 0           | 0      | 0      | 0           | 0      | 0      | 0        | 0      | 0    |       |   |   |   |   |   |
| 014h   | TIMx_EVTGEN | Reserved |    |    |    |    |    |    |    |    |    |    |    |    |    | BGN       | TGN         | CCUDGN      | CC4GN     | CC3GN       | CC2GN       | CC1GN      | UDGN        |           |             |             |        |        |             |        |        |          |        |      |       |   |   |   |   |   |
|        | Reset Value | 0        |    |    |    |    |    |    |    |    |    |    |    |    |    | 0         | 0           | 0           | 0         | 0           | 0           | 0          | 0           | 0         |             |             |        |        |             |        |        |          |        |      |       |   |   |   |   |   |
| 018h   | TIMx_CCMOD1 | Reserved |    |    |    |    |    |    |    |    |    |    |    |    |    | OC2CEN    | OC2MD[2:0]  | OC2PEN      | OC2FEN    | OC2SEL[1:0] | OC1CEN      | OC1MD[2:0] | OC1PEN      | OC1FEN    | OC1SEL[1:0] |             |        |        |             |        |        |          |        |      |       |   |   |   |   |   |
|        | Reset Value | 0        |    |    |    |    |    |    |    |    |    |    |    |    |    | 0         | 0           | 0           | 0         | 0           | 0           | 0          | 0           | 0         | 0           | 0           | 0      | 0      |             |        |        |          |        |      |       |   |   |   |   |   |
| 018h   | TIMx_CCMOD1 | Reserved |    |    |    |    |    |    |    |    |    |    |    |    |    | IC2F[3:0] | IC2PSC[1:0] | IC2SEL[1:0] | IC1F[3:0] | IC1PSC[1:0] | IC1SEL[1:0] |            |             |           |             |             |        |        |             |        |        |          |        |      |       |   |   |   |   |   |
|        | Reset Value | 0        |    |    |    |    |    |    |    |    |    |    |    |    |    | 0         | 0           | 0           | 0         | 0           | 0           | 0          | 0           | 0         | 0           |             |        |        |             |        |        |          |        |      |       |   |   |   |   |   |
| 01Ch   | TIMx_CCMOD2 | Reserved |    |    |    |    |    |    |    |    |    |    |    |    |    | OC4CEN    | OC4MD[2:0]  | OC4PEN      | OC4FEN    | OC4SEL[1:0] | OC3CEN      | OC3MD[2:0] | OC3PEN      | OC3FEN    | OC3SEL[1:0] |             |        |        |             |        |        |          |        |      |       |   |   |   |   |   |
|        | Reset Value | 0        |    |    |    |    |    |    |    |    |    |    |    |    |    | 0         | 0           | 0           | 0         | 0           | 0           | 0          | 0           | 0         | 0           | 0           | 0      |        |             |        |        |          |        |      |       |   |   |   |   |   |
| 01Ch   | TIMx_CCMOD2 | Reserved |    |    |    |    |    |    |    |    |    |    |    |    |    | IC4F[3:0] | IC4PSC[1:0] | IC4SEL[1:0] | IC3F[3:0] | IC3PSC[1:0] | IC3SEL[1:0] |            |             |           |             |             |        |        |             |        |        |          |        |      |       |   |   |   |   |   |
|        | Reset Value | 0        |    |    |    |    |    |    |    |    |    |    |    |    |    | 0         | 0           | 0           | 0         | 0           | 0           | 0          | 0           | 0         | 0           |             |        |        |             |        |        |          |        |      |       |   |   |   |   |   |
| 020h   | TIMx_CCEN   | Reserved |    |    |    |    |    |    |    |    |    |    |    |    |    | CC6P      | CC6EN       | Reserved    | CC5P      | CC5EN       | Reserved    | CC4P       | CC4EN       | CC3NP     | CC3NEN      | CC3P        | CC3EN  | CC2NP  | CC2NEN      | CC2P   | CC2EN  | CC1NP    | CC1NEN | CC1P | CC1EN |   |   |   |   |   |
|        | Reset Value | 0        |    |    |    |    |    |    |    |    |    |    |    |    |    | 0         | 0           | 0           | 0         | 0           | 0           | 0          | 0           | 0         | 0           | 0           | 0      | 0      | 0           | 0      | 0      | 0        |        |      |       |   |   |   |   |   |

|      |             |          |              |            |     |        |          |             |             |            |   |        |        |          |   |   |   |  |
|------|-------------|----------|--------------|------------|-----|--------|----------|-------------|-------------|------------|---|--------|--------|----------|---|---|---|--|
| 024h | TIMx_CNT    | Reserved | CNT[15:0]    |            |     |        |          |             |             |            |   |        |        |          |   |   |   |  |
|      | Reset Value |          | 0            | 0          | 0   | 0      | 0        | 0           | 0           | 0          | 0 | 0      | 0      | 0        | 0 | 0 | 0 |  |
| 028h | TIMx_PSC    | Reserved | PSC[15:0]    |            |     |        |          |             |             |            |   |        |        |          |   |   |   |  |
|      | Reset Value |          | 0            | 0          | 0   | 0      | 0        | 0           | 0           | 0          | 0 | 0      | 0      | 0        | 0 | 0 | 0 |  |
| 02Ch | TIMx_AR     | Reserved | AR[15:0]     |            |     |        |          |             |             |            |   |        |        |          |   |   |   |  |
|      | Reset Value |          | 1            | 1          | 1   | 1      | 1        | 1           | 1           | 1          | 1 | 1      | 1      | 1        | 1 | 1 | 1 |  |
| 030h | TIMx_REPCNT | Reserved | REPCNT[7:0]  |            |     |        |          |             |             |            |   |        |        |          |   |   |   |  |
|      | Reset Value |          | 0            | 0          | 0   | 0      | 0        | 0           | 0           | 0          | 0 | 0      | 0      | 0        |   |   |   |  |
| 034h | TIMx_CCDAT1 | Reserved | CCDAT1[15:0] |            |     |        |          |             |             |            |   |        |        |          |   |   |   |  |
|      | Reset Value |          | 0            | 0          | 0   | 0      | 0        | 0           | 0           | 0          | 0 | 0      | 0      | 0        | 0 | 0 | 0 |  |
| 038h | TIMx_CCDAT2 | Reserved | CCDAT2[15:0] |            |     |        |          |             |             |            |   |        |        |          |   |   |   |  |
|      | Reset Value |          | 0            | 0          | 0   | 0      | 0        | 0           | 0           | 0          | 0 | 0      | 0      | 0        | 0 | 0 | 0 |  |
| 03Ch | TIMx_CCDAT3 | Reserved | CCDAT3[15:0] |            |     |        |          |             |             |            |   |        |        |          |   |   |   |  |
|      | Reset Value |          | 0            | 0          | 0   | 0      | 0        | 0           | 0           | 0          | 0 | 0      | 0      | 0        | 0 | 0 | 0 |  |
| 040h | TIMx_CCDAT4 | Reserved | CCDAT4[15:0] |            |     |        |          |             |             |            |   |        |        |          |   |   |   |  |
|      | Reset Value |          | 0            | 0          | 0   | 0      | 0        | 0           | 0           | 0          | 0 | 0      | 0      | 0        | 0 | 0 | 0 |  |
| 044h | TIMx_BKDT   | Reserved | MOEN         | AOEN       | BKP | BKEN   | OSSR     | OSSI        | LCKCFG[1:0] | DTGN[7:0]  |   |        |        |          |   |   |   |  |
|      | Reset Value |          | 0            | 0          | 0   | 0      | 0        | 0           | 0           | 0          | 0 | 0      | 0      | 0        | 0 | 0 | 0 |  |
| 048h | TIMx_DCTRL  | Reserved | DBLEN[4:0]   |            |     |        | Reserved | DBADDR[4:0] |             |            |   |        |        |          |   |   |   |  |
|      | Reset Value |          | 0            | 0          | 0   | 0      |          | 0           | 0           | 0          | 0 | 0      | 0      |          |   |   |   |  |
| 04Ch | TIMx_DADDR  | Reserved | BURST[15:0]  |            |     |        |          |             |             |            |   |        |        |          |   |   |   |  |
|      | Reset Value |          | 0            | 0          | 0   | 0      | 0        | 0           | 0           | 0          | 0 | 0      | 0      | 0        | 0 | 0 | 0 |  |
| 050h | TIMx_CCMOD3 | Reserved | OC6CEN       | OC6MD[2:0] |     | OC6PEN | OC6FEN   | Reserved    | OC5CEN      | OC5MD[2:0] |   | OC5PEN | OC5FEN | Reserved |   |   |   |  |
|      | Reset Value |          | 0            | 0          | 0   | 0      | 0        |             | 0           | 0          | 0 | 0      | 0      |          | 0 |   |   |  |
| 054h | TIMx_CCDAT5 | Reserved | CCDAT5[15:0] |            |     |        |          |             |             |            |   |        |        |          |   |   |   |  |
|      | Reset Value |          | 0            | 0          | 0   | 0      | 0        | 0           | 0           | 0          | 0 | 0      | 0      | 0        | 0 | 0 | 0 |  |
| 058h | TIMx_CCDAT6 | Reserved | CCDAT6[15:0] |            |     |        |          |             |             |            |   |        |        |          |   |   |   |  |
|      | Reset Value |          | 0            | 0          | 0   | 0      | 0        | 0           | 0           | 0          | 0 | 0      | 0      | 0        | 0 | 0 | 0 |  |

### 11.4.2 Control register 1 (TIMx\_CTRL1)

Offset address: 0x00

Reset value: 0x0000 0000

|          |          |    |       |              |           |       |             |     |       |      |        |              |         |         |
|----------|----------|----|-------|--------------|-----------|-------|-------------|-----|-------|------|--------|--------------|---------|---------|
| Reserved |          |    |       |              |           |       |             |     |       |      | 18     | 17           | 16      |         |
|          |          |    |       |              |           |       |             |     |       |      | PBKPEN | LOCKUP<br>EN |         |         |
| 15       | 14       | 12 | 11    | 10           | 9         | 8     | 7           | 6   | 5     | 4    | 3      | 2            | rw<br>1 | rw<br>0 |
| CLRSEL   | Reserved |    | C1SEL | IOM<br>BKPEN | CLKD[1:0] | ARPEN | CAMSEL[1:0] | DIR | ONEPM | UPRS | UPDIS  | CNTEN        |         |         |
| rw       |          |    | rw    | rw           | rw        | rw    | rw          | rw  | rw    | rw   | rw     | rw           |         |         |

| Bit field | Name        | Description  |
|-----------|-------------|--|
| 31:18     | Reserved    | Reserved, the reset value must be maintained   |
| 17        | PBKPEN      | PVD as BKP enable<br>0: Disable<br>1: Enable<br><i>Note: Before operating this bit, the extended mode of the chip must be turned on (set PWR_CTRL3.EXMODE)</i>   |
| 16        | LBKPEN      | LockUp as BKP enable<br>0: Disable<br>1: Enable<br><i>Note: Before operating this bit, the extended mode of the chip must be turned on (set PWR_CTRL3.EXMODE)</i>  |
| 15        | CLRSEL      | OCxREF clear selection<br>0: Select the external OCxREF clear from ETR<br>1: Select the internal OCxREF clear from comparator<br><i>Note: Before operating this bit, the extended mode of the chip must be turned on (set PWR_CTRL3.EXMODE)</i>  |
| 14:12     | Reserved    | Reserved, the reset value must be maintained   |
| 11        | C1SEL       | Channel 1 selection<br>0: Select external CH1 signal from IOM<br>1: Select internal CH1 signal from COMP<br><i>Note: Before operating this bit, the extended mode of the chip must be turned on (set PWR_CTRL3.EXMODE)</i>   |
| 10        | IOMBKPEN    | Enabling IOM as BKP<br>0: Enable. Select external break (from IOM) signal.<br>1: Disable. Select internal break (from COMP) signal.<br><i>Note: Before operating this bit, the extended mode of the chip must be turned on (set PWR_CTRL3.EXMODE)</i>  |
| 9:8       | CLKD[1:0]   | Clock division<br>CLKD[1:0] indicates the division ratio between CK_INT (timer clock) and DTS (clock used for dead-time generator and digital filters (ETR, TIx))<br>00: $t_{DTS} = t_{CK\_INT}$<br>01: $t_{DTS} = 2 \times t_{CK\_INT}$<br>10: $t_{DTS} = 4 \times t_{CK\_INT}$<br>11: Reserved, do not use this configuration  |
| 7         | ARPEN       | ARPEN: Auto-reload preload enable<br>0: Shadow register disable for TIMx_AR register<br>1: Shadow register enable for TIMx_AR register   |
| 6:5       | CAMSEL[1:0] | Center-aligned mode selection<br>00: Edge-aligned mode. TIMx_CTRL1.DIR specifies up-counting or down-counting.<br>01: Center-aligned mode 1. The counter counts in center-aligned mode, and the output compare interrupt flag bit is set to 1 when down-counting.<br>10: Center-aligned mode 2. The counter counts in center-aligned mode, and the output compare interrupt flag bit is set to 1 when up-counting. |

| Bit field | Name  | Description   |
|-----------|-------|---|
|           |       | 11: Center-aligned mode 3. The counter counts in center-aligned mode, and the output compare interrupt flag bit is set to 1 when up-counting or down-counting.<br><i>Note: Switching from edge-aligned mode to center-aligned mode is not allowed when the counter is still enabled (TIMx_CTRL1.CNTEN = 1).</i>   |
| 4         | DIR   | Direction<br>0: Up-counting<br>1: Down-counting<br><i>Note: This bit is read-only when the counter is configured in center-aligned mode or encoder mode.</i>  |
| 3         | ONEPM | One-pulse mode<br>0: Disable one-pulse mode, the counter counts are not affected when an update event occurs.<br>1: Enable one-pulse mode, the counter stops counting when the next update event occurs (clearing TIMx_CTRL1.CNTEN bit)   |
| 2         | UPRS  | Update request source<br>This bit is used to select the UEV event sources by software.<br>0: If update interrupt or DMA request is enabled, any of the following events will generate an update interrupt or DMA request: <ul style="list-style-type: none"> <li>– Counter overflow/underflow</li> <li>– The TIMx_EVTGEN.UDGN bit is set</li> <li>– Update generation from the slave mode controller</li> </ul> 1: If update interrupt or DMA request is enabled, only counter overflow/underflow will generate update interrupt or DMA request   |
| 1         | UPDIS | Update disable<br>This bit is used to enable/disable the Update event (UEV) events generation by software.<br>0: Enable UEV. UEV will be generated if one of following condition been fulfilled: <ul style="list-style-type: none"> <li>– Counter overflow/underflow</li> <li>– The TIMx_EVTGEN.UDGN bit is set</li> <li>– Update generation from the slave mode controller</li> </ul> Shadow registers will update with preload value.<br>1: UEV disabled. No update event is generated, and the shadow registers (AR, PSC, and CCDATx) keep their values. If the TIMx_EVTGEN.UDGN bit is set or a hardware reset is issued by the slave mode controller, the counter and prescaler are reinitialized. |
| 0         | CNTEN | Counter Enable<br>0: Disable counter<br>1: Enable counter<br><i>Note: external clock, gating mode and encoder mode can only work after TIMx_CTRL1.CNTEN bit is set in the software. Trigger mode can automatically set TIMx_CTRL1.CNTEN bit by hardware.</i>  |

### 11.4.3 Control register 2 (TIMx\_CTRL2)

Offset address: 0x04

Reset value: 0x0000 0000

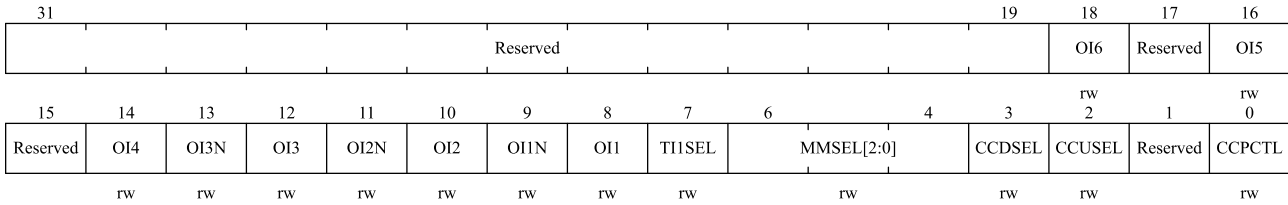

| Bit field | Name       | Description   |
|-----------|------------|---|
| 31:19     | Reserved   | Reserved, the reset value must be maintained  |
| 18        | OI6        | Output idle state 6 (OC6 output). See TIMx_CTRL2.OI1 bit.   |
| 17        | Reserved   | Reserved, the reset value must be maintained  |
| 16        | OI5        | Output idle state 5 (OC5 output). See TIMx_CTRL2.OI1 bit.   |
| 15        | Reserved   | Reserved, the reset value must be maintained  |
| 14        | OI4        | Output idle state 4 (OC4 output). See TIMx_CTRL2.OI1 bit.   |
| 13        | OI3N       | Output idle state 3 (OC3N output). See TIMx_CTRL2.OI1N bits.  |
| 12        | OI3        | Output idle state 3 (OC3 output). See TIMx_CTRL2.OI1 bit.   |
| 11        | OI2N       | Output idle state 2 (OC2N output). See TIMx_CTRL2.OI1N bits.  |
| 10        | OI2        | Output idle state 2 (OC2 output). See TIMx_CTRL2.OI1 bit.   |
| 9         | OI1N       | Output Idle state 1 (OC1N Output)<br>0: When TIMx_BKDT.MOEN = 0, after dead-time OC1N = 0<br>1: When TIMx_BKDT.MOEN = 0, after dead-time OC1N = 1   |
| 8         | OI1        | Output Idle state 1<br>0: When TIMx_BKDT.MOEN = 0, if OC1N is implemented, after dead-time OC1 = 0<br>1: When TIMx_BKDT.MOEN = 0, if OC1N is implemented, after dead-time OC1 = 1   |
| 7         | TI1SEL     | TI1 selection<br>0: TIMx_CH1 pin connected to TI1 input.<br>1: TIMx_CH1, TIMx_CH2, and TIMx_CH3 pins are XOR connected to the TI1 input.  |
| 6:4       | MMSEL[2:0] | Master Mode Selection<br>These 3 bits (TIMx_CTRL2.MMSEL [2:0]) are used to select the synchronization information (TRGO) sent to the slave timer in the master mode. Possible combinations are as follows:<br>000: Reset –When the TIMx_EVTGEN.UDGN is set or a reset is generated by the slave mode controller, a TRGO pulse occurs. And in the latter case, the signal on TRGO is delayed compared to the actual reset.<br>001: Enable - The TIMx_CTRL1.CNTEN bit is used as the trigger output (TRGO). Sometimes you need to start multiple timers at the same time or enable slave timer for a period of time.<br>The counter enable signal is set when TIMx_CTRL1.CNTEN bit is set or the trigger input in gated mode is high.<br>When the counter enable signal is controlled by the trigger input, there is a delay on TRGO except if the master/slave mode is selected (see the description of the TIMx_SMCTRL.MSMD bit).<br>010: Update - The update event is selected as the trigger output (TRGO). For example, a master timer clock can be used as a slave timer prescaler. |

| Bit field | Name     | Description   |
|-----------|----------|---|
|           |          | 011: Compare pulse - Triggers the output to send a positive pulse (TRGO) when the TIMx_STS.CC1ITF is to be set (even if it is already high), when a capture or a comparison succeeds.<br>100: Compare - OC1REF signal is used as the trigger output (TRGO).<br>101: Compare - OC2REF signal is used as the trigger output (TRGO).<br>110: Compare - OC3REF signal is used as the trigger output (TRGO).<br>111: Compare - OC4REF signal is used as the trigger output (TRGO). |
| 3         | CCDSEL   | Capture/compare DMA selection<br>0: When a CCx event occurs, a DMA request for CCx is sent.<br>1: When an update event occurs, a DMA request for CCx is sent.   |
| 2         | CCUSEL   | Capture/compare control update selection<br>0: If TIMx_CTRL2.CCPCTL = 1, they can only be updated by setting CCUDGN bits<br>1: If TIMx_CTRL2.CCPCTL = 1, they can be updated by setting CCUDGN bits or a rising edge on TRGI.<br><i>Note: This bit only applied to channels with complementary outputs.</i>   |
| 1         | Reserved | Reserved, the reset value must be maintained  |
| 0         | CCPCTL   | Capture/ Compare preloaded control<br>0: No preloading of CCxEN, CCxNEN, CCxP, CCxNP and OCxMD bits occurs.<br>1: Preloading of CCxEN, CCxNEN, CCxP, CCxNP and OCxMD bits occurs. they are updated only when a commutation event COM occurs (CCUDGN bit set or rising edge on TRGI depending on CCUSEL bit)<br><i>Note: This bit only applied to channels with complementary outputs.</i>   |

### 11.4.4 Slave mode control register (TIMx\_SMCTRL)

Offset address: 0x08

Reset value: 0x0000

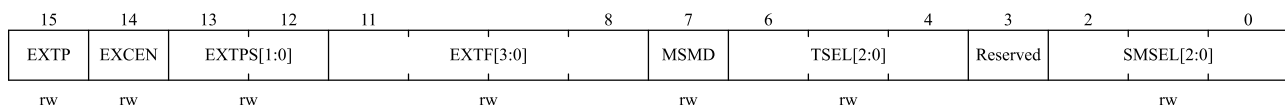

| Bit field | Name  | Description   |
|-----------|-------|---|
| 15        | EXTP  | External trigger polarity<br>This bit is used to select whether the trigger operation is to use ETR or the inversion of ETR.<br>0: ETR active at high level or rising edge.<br>1: ETR active at low level or falling edge.        |
| 14        | EXCEN | External clock enable<br>This bit is used to enable external clock mode 2, and the counter is driven by any active edge on the ETRF signal in this mode.<br>0: External clock mode 2 disable.<br>1: External clock mode 2 enable. |

| Bit field | Name       | Description  |
|-----------|------------|--|
|           |            | <p><i>Note 1: When external clock mode 1 and external clock mode 2 are enabled at the same time, the input of the external clock is ETRF.</i></p> <p><i>Note 2: The following slave modes can be used simultaneously with external clock mode 2: reset mode, gated mode and trigger mode; However, TRGI cannot connect to ETRF (TIMx_SMCTRL.TSEL ≠ '111').</i></p> <p><i>Note 3: Setting the TIMx_SMCTRL.EXCEN bit has the same effect as selecting external clock mode 1 and connecting TRGI to ETRF (TIMx_SMCTRL.SMSEL = 111 and TIMx_SMCTRL.TSEL = 111).</i></p>  |
| 13:12     | EXTPS[1:0] | <p>External trigger prescaler</p> <p>The frequency of the external trigger signal ETRP must be at most 1/4 of TIMxCLK frequency. When a faster external clock is input, a prescaler can be used to reduce the frequency of ETRP.</p> <p>00: Prescaler disable<br/>           01: ETRP frequency divided by 2<br/>           10: ETRP frequency divided by 4<br/>           11: ETRP frequency divided by 8</p>   |
| 11:8      | EXTF[3:0]  | <p>External trigger filter</p> <p>These bits are used to define the frequency at which the ETRP signal is sampled and the bandwidth of the ETRP digital filtering. In effect, the digital filter is an event counter that generates a validate output after consecutive N events are recorded.</p> <p>0000: No filter, sampling at f<sub>DTS</sub><br/>           0001: f<sub>SAMPLING</sub> = f<sub>CK_INT</sub>, N = 2<br/>           0010: f<sub>SAMPLING</sub> = f<sub>CK_INT</sub>, N = 4<br/>           0011: f<sub>SAMPLING</sub> = f<sub>CK_INT</sub>, N = 8<br/>           0100: f<sub>SAMPLING</sub> = f<sub>DTS</sub>/2, N = 6<br/>           0101: f<sub>SAMPLING</sub> = f<sub>DTS</sub>/2, N = 8<br/>           0110: f<sub>SAMPLING</sub> = f<sub>DTS</sub>/4, N = 6<br/>           0111: f<sub>SAMPLING</sub> = f<sub>DTS</sub>/4, N = 8<br/>           1000: f<sub>SAMPLING</sub> = f<sub>DTS</sub>/8, N = 6<br/>           1001: f<sub>SAMPLING</sub> = f<sub>DTS</sub>/8, N = 8<br/>           1010: f<sub>SAMPLING</sub> = f<sub>DTS</sub>/16, N = 5<br/>           1011: f<sub>SAMPLING</sub> = f<sub>DTS</sub>/16, N = 6<br/>           1100: f<sub>SAMPLING</sub> = f<sub>DTS</sub>/16, N = 8<br/>           1101: f<sub>SAMPLING</sub> = f<sub>DTS</sub>/32, N = 5<br/>           1110: f<sub>SAMPLING</sub> = f<sub>DTS</sub>/32, N = 6<br/>           1111: f<sub>SAMPLING</sub> = f<sub>DTS</sub>/32, N = 8</p> |
| 7         | MSMD       | <p>Master/ Slave mode</p> <p>0: No action<br/>           1: Events on the trigger input (TRGI) are delayed to allow a perfect synchronization between the current timer (via TRGO) and its slaves. This is useful when several timers are required to be synchronized to a single external event.</p>  |

| Bit field | Name       | Description  |
|-----------|------------|--|
| 6:4       | TSEL[2:0]  | <p>Trigger selection</p> <p>These 3 bits are used to select the trigger input of the synchronous counter.</p> <p>000: Internal trigger 0 (ITR0) 100: TI1 edge detector (TI1F_ED)<br/>           001: Internal trigger 1 (ITR1) 101: Filtered timer input 1(TI1FP1)<br/>           010: Internal trigger 2 (ITR2) 110: Filtered timer input 2 (TI2FP2)<br/>           011: Internal trigger 3 (ITR3) 111: External triggered Input (ETRF)</p> <p>For more details on ITRx, see Table 11-3 below.</p> <p><i>Note: These bits must be changed only when not in use (e. g. TIMx_SMCTRL.SMSEL=000) to avoid false edge detection at the transition.</i></p>   |
| 3         | Reserved   | Reserved, the reset value must be maintained   |
| 2:0       | SMSEL[2:0] | <p>Slave mode selection</p> <p>When an external signal is selected, the active edge of the trigger signal (TRGI) is linked to the selected external input polarity (see input control register and control register description)</p> <p>000: Disable slave mode. If TIMx_CTRL1.CNTEN = 1, the prescaler is driven directly by the internal clock.</p> <p>001: Encoder mode 1. According to the level of TI2FP2, the counter up-counting or down-counting on the edge of TI1FP1.</p> <p>010: Encoder mode 2. According to the level of TI1FP1, the counter up-counting or down-counting on the edge of TI2FP2.</p> <p>011: Encoder mode 3. According to the input level of another signal, the counter up-counting or down-counting on the edges of TI2FP1 and TI2FP2.</p> <p>100: Reset mode. On the rising edge of the selected trigger input (TRGI), the counter is reinitialized and the shadow register is updated.</p> <p>101: Gated mode. When the trigger input (TRGI) is high, the clock of the counter is enabled. Once the trigger input becomes low, the counter stops counting, but is not reset. In this mode, the start and stop of the counter are controlled.</p> <p>110: Trigger mode. When a rising edge occurs on the trigger input (TRGI), the counter is started but not reset. In this mode, only the start of the counter is controlled.</p> <p>111: External clock mode 1. The counter is clocked by the rising edge of the selected trigger input (TRGI).</p> <p><i>Note: Do not use gated mode if TI1F_ED is selected as the trigger input (TIMx_SMCTRL.TSEL=100). This is because TI1F_ED outputs a pulse for each TI1F transition, whereas gated mode checks the level of the triggered input.</i></p> |

Table 11-3 TIMx internal trigger connection

| Slave timer | ITR0 (TSEL = 000) | ITR1 (TSEL = 001) | ITR2 (TSEL = 010) | ITR3 (TSEL = 011) |
|-------------|-------------------|-------------------|-------------------|-------------------|
| <b>TIM1</b> | TIM5              | TIM2              | TIM3              | TIM4              |
| <b>TIM8</b> | TIM1              | TIM2              | TIM4              | TIM5              |

### 11.4.5 DMA/Interrupt enable registers (TIMx\_DINTEN)

Offset address: 0x0C

Reset value: 0x0000

|          |      |        |        |        |        |        |      |      |      |        |        |        |        |        |      |
|----------|------|--------|--------|--------|--------|--------|------|------|------|--------|--------|--------|--------|--------|------|
| 15       | 14   | 13     | 12     | 11     | 10     | 9      | 8    | 7    | 6    | 5      | 4      | 3      | 2      | 1      | 0    |
| Reserved | TDEN | COMDEN | CC4DEN | CC3DEN | CC2DEN | CC1DEN | UDEN | BIEN | TIEN | COMIEN | CC4IEN | CC3IEN | CC2IEN | CC1IEN | UIEN |
|          | rw   | rw     | rw     | rw     | rw     | rw     | rw   | rw   | rw   | rw     | rw     | rw     | rw     | rw     | rw   |

| Bit field | Name     | Description   |
|-----------|----------|---|
| 15        | Reserved | Reserved, the reset value must be maintained  |
| 14        | TDEN     | Trigger DMA request enable<br>0: Disable trigger DMA request<br>1: Enable trigger DMA request                               |
| 13        | COMDEN   | COM DMA request enable<br>0: Disable COM DMA request<br>1: Enable COM DMA request   |
| 12        | CC4DEN   | Capture/Compare 4 DMA request enable<br>0: Disable capture/compare 4 DMA request<br>1: Enable capture/compare 4 DMA request |
| 11        | CC3DEN   | Capture/Compare 3 DMA request enable<br>0: Disable capture/compare 3 DMA request<br>1: Enable capture/compare 3 DMA request |
| 10        | CC2DEN   | Capture/Compare 2 DMA request enable<br>0: Disable capture/compare 2 DMA request<br>1: Enable capture/compare 2 DMA request |
| 9         | CC1DEN   | Capture/Compare 1 DMA request enable<br>0: Disable capture/compare 1 DMA request<br>1: Enable capture/compare 1 DMA request |
| 8         | UDEN     | Update DMA request enable<br>0: Disable update DMA request<br>1: Enable update DMA request                                  |
| 7         | BIEN     | Break interrupt enable<br>0: Disable break interrupt<br>1: Enable break interrupt   |
| 6         | TIEN     | Trigger interrupt enable<br>0: Disable trigger interrupt<br>1: Enable trigger interrupt                                     |
| 5         | COMIEN   | COM interrupt enable<br>0: Disable COM interrupt<br>1: Enable COM interrupt   |
| 4         | CC4IEN   | Capture/Compare 4 interrupt enable<br>0: Disable capture/compare 4 interrupt<br>1: Enable capture/compare 4 interrupt       |
| 3         | CC3IEN   | Capture/Compare 3 interrupt enable<br>0: Disable capture/compare 3 interrupt<br>1: Enable capture/compare 3 interrupts      |

| Bit field | Name   | Description  |
|-----------|--------|--|
| 2         | CC2IEN | Capture/Compare 2 interrupt enable<br>0: Disable capture/compare 2 interrupt<br>1: Enables capture/compare 2 interrupts  |
| 1         | CC1IEN | Capture/Compare 1 interrupt enable<br>0: Disable capture/compare 1 interrupt<br>1: Enables capture/comparing 1 interrupt |
| 0         | UIEN   | Update interrupt enable<br>0: Disable update interrupt<br>1: Enables update interrupt                                    |

### 11.4.6 Status registers (TIMx\_STS)

Offset address: 0x10

Reset value: 0x0000 0000

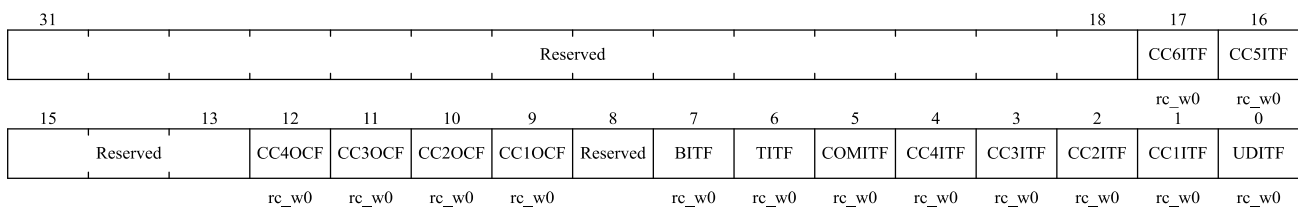

| Bit field | Name     | Description  |
|-----------|----------|--|
| 31: 18    | Reserved | Reserved, the reset value must be maintained   |
| 17        | CC6ITF   | Capture/Compare 6 interrupt flag<br>See TIMx_STS.CC1ITF description.   |
| 16        | CC5ITF   | Capture/Compare 5 interrupt flag<br>See TIMx_STS.CC1ITF description.   |
| 15: 13    | Reserved | Reserved, the reset value must be maintained   |
| 12        | CC4OCF   | Capture/Compare 4 overcapture flag<br>See TIMx_STS.CC1OCF description.   |
| 11        | CC3OCF   | Capture/Compare 3 overcapture flag<br>See TIMx_STS.CC1OCF description.   |
| 10        | CC2OCF   | Capture/Compare 2 overcapture flags<br>See TIMx_STS.CC1OCF description.  |
| 9         | CC1OCF   | Capture/Compare 1 overcapture flag<br>This bit is set by hardware only when the corresponding channel is configured in input capture mode. Cleared by software writing 0.<br>0: No overcapture occurred<br>1: TIMx_STS.CC1ITF was already set when the value of the counter has been captured in the TIMx_CCDAT1 register. |
| 8         | Reserved | Reserved, the reset value must be maintained   |

| Bit field | Name   | Description  |
|-----------|--------|--|
| 7         | BITF   | Break interrupt flag<br>This bit is set by hardware once the brake input is active. This bit is cleared by software when the brake input becomes inactive.<br>0: No break event occurred<br>1: An active level has been detected   |
| 6         | TITF   | Trigger interrupt flag<br>This bit is set by hardware when an active edge is detected on the TRGI input when the slave mode controller is in a mode other than gated. This bit is set by hardware when any edge in gated mode is detected. This bit is cleared by software.<br>0: No trigger event occurred<br>1: Trigger interrupt occurred   |
| 5         | COMITF | COM interrupt flag<br>This bit is set by hardware once a COM event is generated (when TIMx_CCEN.CCxEN, TIMx_CCEN.CCxNEN, TIMx_CCMOD1.OCxMD have been updated). This bit is cleared by software.<br>0: No COM event occurred<br>1: COM interrupt pending  |
| 4         | CC4ITF | Capture/Compare 4 interrupt flag<br>See TIMx_STS.CC1ITF description.   |
| 3         | CC3ITF | Capture/Compare 3 interrupt flag<br>See TIMx_STS.CC1ITF description.   |
| 2         | CC2ITF | Capture/Compare 2 interrupt flag<br>See TIMx_STS.CC1ITF description.   |
| 1         | CC1ITF | Capture/Compare 1 interrupt flag<br><b>When the corresponding channel of CC1 is in output mode:</b><br>Except in center-aligned mode, this bit is set by hardware when the counter value is the same as the compare value (see TIMx_CTRL1.CAMSEL bit description). This bit is cleared by software.<br>0: No match occurred.<br>1: The value of TIMx_CNT is the same as the value of TIMx_CCDA1.<br>When the value of TIMx_CCDA1 is greater than the value of TIMx_AR, the TIMx_STS.CC1ITF bit will go high if the counter overflows (in up-counting and up/down-counting modes) and underflows in down-counting mode.<br><b>When the corresponding channel of CC1 is in input mode:</b><br>This bit is set by hardware when the capture event occurs. This bit is cleared by software or by reading TIMx_CCDA1.<br>0: No input capture occurred.<br>1: Input capture occurred. Counter value has captured in the TIMx_CCDA1. An edge with the same polarity as selected has been detected on IC1. |
| 0         | UDITF  | Update interrupt flag<br>This bit is set by hardware when an update event occurs under the following conditions: <ul style="list-style-type: none"> <li>– When TIMx_CTRL1.UPDIS = 0, and repeat counter value overflow or underflow (An update event is generated when the repeat counter equals 0).</li> </ul>  |

| Bit field | Name | Description   |
|-----------|------|---|
|           |      | When TIMx_CTRL1.UPRS = 0, TIMx_CTRL1.UPDIS = 0, and set the TIMx_EVTGEN.UDGN bit by software to reinitialize the CNT.<br>When TIMx_CTRL1.UPRS = 0, TIMx_CTRL1.UPDIS = 0, and the counter CNT is reinitialized by the trigger event. (See TIMx_SMCTRL Register description)<br>This bit is cleared by software.<br>0: No update event occurred<br>1: Update interrupt occurred |

### 11.4.7 Event generation registers (TIMx\_EVTGEN)

Offset address: 0x14

Reset values: 0x0000

|          |   |   |   |   |   |   |   |     |     |        |       |       |       |       |      |
|----------|---|---|---|---|---|---|---|-----|-----|--------|-------|-------|-------|-------|------|
| 15       | 8 | 7 | 6 | 5 | 4 | 3 | 2 | 1   | 0   |        |       |       |       |       |      |
| Reserved |   |   |   |   |   |   |   | BGN | TGN | CCUDGN | CC4GN | CC3GN | CC2GN | CC1GN | UDGN |
|          |   |   |   |   |   |   |   |     |     |        |       |       |       |       |      |
|          |   |   |   |   |   |   |   |     |     |        |       |       |       |       |      |

| Bit field | Name     | Description   |
|-----------|----------|---|
| 15: 8     | Reserved | Reserved, the reset value must be maintained  |
| 7         | BGN      | Break generation<br>This bit can generate a brake event when set by software. And at this time TIMx_BKDT.MOEN = 0, TIMx_STS.BITF = 1, if the corresponding interrupt and DMA are enabled, the corresponding interrupt and DMA will be generated. This bit is automatically cleared by hardware.<br>0: No action<br>1: Generated a break event               |
| 6         | TGN      | Trigger generation<br>This bit can generate a trigger event when set by software. And at this time TIMx_STS.TITF = 1, if the corresponding interrupt and DMA are enabled, the corresponding interrupt and DMA will be generated. This bit is automatically cleared by hardware.<br>0: No action<br>1: Generated a trigger event                             |
| 5         | CCUDGN   | Capture/Compare control update generation<br>This bit is set by software. And if TIMx_CTRL2.CCPCTL = 1 at this time, the CCxEN, CCxNEN and OCxMD bits are allowed to be updated. This bit is automatically cleared by hardware.<br>0: No action<br>1: Generated a COM event<br><i>Note: This bit is only valid for channels with complementary outputs.</i> |
| 4         | CC4GN    | Capture/Compare 4 generation<br>See TIMx_EVTGEN.CC1GN description.  |
| 3         | CC3GN    | Capture/Compare 3 generation<br>See TIMx_EVTGEN.CC1GN description.  |
| 2         | CC2GN    | Capture/Compare 2 generation<br>See TIMx_EVTGEN.CC1GN description.  |

| Bit field | Name  | Description   |
|-----------|-------|---|
| 1         | CC1GN | <p>Capture/Compare 1 generation</p> <p>This bit can generate a capture/compare event when set by software. This bit is automatically cleared by hardware.</p> <p>When the corresponding channel of CC1 is in output mode:</p> <p>The TIMx_STS.CC1ITF flag will be pulled high, if the corresponding interrupt and DMA are enabled, the corresponding interrupt and DMA will be generated.</p> <p>When the corresponding channel of CC1 is in input mode:</p> <p>TIMx_CCDAT1 will capture the current counter value, and the TIMx_STS.CC1ITF flag will be pulled high, if the corresponding interrupt and DMA are enabled, the corresponding interrupt and DMA will be generated. If The TIMx_STS.CC1ITF is already pulled high, pull TIMx_STS.CC1OCF high.</p> <p>0: No action<br/>1: Generated a CC1 capture/compare event</p> |
| 0         | UDGN  | <p>Update generation</p> <p>This bit can generate an update event when set by software. And at this time the counter will be reinitialized, the prescaler counter will be cleared, the counter will be cleared in center-aligned or up-counting mode, but take TIMx_AR in down-counting mode the value of the register. This bit is automatically cleared by hardware.</p> <p>0: No action<br/>1: Generated an update event</p>   |

### 11.4.8 Capture/compare mode register 1 (TIMx\_CCMOD1)

Offset address: 0x18

Reset value: 0x0000

Channels can be used for input (capture mode) or output (compare mode), and the direction of the channel is defined by the corresponding CCxSEL bit. The other bits of the register act differently in input and output modes. OCx describes the function of a channel in output mode, ICx describes the function of a channel in input mode. Hence, please note that the same bit can have different meanings for output mode and for input mode.

Output compare mode:

|        |           |    |        |        |             |   |        |           |   |        |        |             |   |
|--------|-----------|----|--------|--------|-------------|---|--------|-----------|---|--------|--------|-------------|---|
| 15     | 14        | 12 | 11     | 10     | 9           | 8 | 7      | 6         | 4 | 3      | 2      | 1           | 0 |
| OC2CEN | OC2M[2:0] |    | OC2PEN | OC2FEN | CC2SEL[1:0] |   | OC1CEN | OC1M[2:0] |   | OC1PEN | OC1FEN | CC1SEL[1:0] |   |
| rw     | rw        |    | rw     | rw     | rw          |   | rw     | rw        |   | rw     | rw     | rw          |   |

| Bit field | Name       | Description                     |
|-----------|------------|---------------------------------|
| 15        | OC2CEN     | Output Compare 2 clear enable   |
| 14:12     | OC2MD[2:0] | Output Compare 2 mode           |
| 11        | OC2PEN     | Output Compare 2 preload enable |
| 10        | OC2FEN     | Output Compare 2 fast enable    |

| Bit field | Name        | Description   |
|-----------|-------------|---|
| 9:8       | CC2SEL[1:0] | <p>Capture/compare 2 selection</p> <p>These bits are used to select the input/output and input mapping of the channel</p> <p>00: CC2 channel is configured as output</p> <p>01: CC2 channel is configured as input, IC2 is mapped on TI2</p> <p>10: CC2 channel is configured as input, IC2 is mapped on TI1</p> <p>11: CC2 channel is configured as input, IC2 is mapped on TRC. This mode is only active when the internal trigger input is selected by TIMx_SMCTRL.TSEL.</p> <p><i>Note: CC2SEL is writable only when the channel is off (TIMx_CCEN.CC2EN = 0).</i></p>  |
| 7         | OC1CEN      | <p>Output Compare 1 clear enable</p> <p>0: OC1REF is not affected by ETRF input level</p> <p>1: OC1REF is cleared immediately when the ETRF input level is detected as high</p>   |
| 6:4       | OC1MD[2:0]  | <p>Output Compare 1 mode</p> <p>These bits are used to manage the output reference signal OC1REF, which determines the values of OC1 and OC1N, and is valid at high levels, while the active levels of OC1 and OC1N depend on the TIMx_CCEN.CC1P and TIMx_CCEN.CC1NP bits.</p> <p>000: Frozen. Comparison between TIMx_CCDAT1 register and counter TIMx_CNT has no effect on OC1REF signal.</p> <p>001: Set channel 1 to the active level on match. When TIMx_CCDAT1 = TIMx_CNT, OC1REF signal will be forced high.</p> <p>010: Set channel 1 as inactive level on match. When TIMx_CCDAT1 = TIMx_CNT, OC1REF signal will be forced low.</p> <p>011: Toggle. When TIMx_CCDAT1 = TIMx_CNT, OC1REF signal will be toggled.</p> <p>100: Force to inactive level. OC1REF signal is forced low.</p> <p>101: Force to active level. OC1REF signal is forced high.</p> <p>110: PWM mode 1 - In up-counting mode, if TIMx_CNT &lt; TIMx_CCDAT1, OC1REF signal of channel 1 is high, otherwise it is low. In down-counting mode, if TIMx_CNT &gt; TIMx_CCDAT1, OC1REF signal of channel 1 is low, otherwise it is high.</p> <p>111: PWM mode 2 - In up-counting mode, if TIMx_CNT &lt; TIMx_CCDAT1, OC1REF signal of channel 1 is low, otherwise it is high. In down-counting mode, if TIMx_CNT &gt; TIMx_CCDAT1, OC1REF signal of channel 1 is high, otherwise it is low.</p> <p><i>Note 1: In PWM mode 1 or PWM mode 2, the OC1REF level changes only when the comparison result changes or when the output compare mode is switched from frozen mode to PWM mode.</i></p> |
| 3         | OC1PEN      | <p>Output Compare 1 preload enable</p> <p>0: Disable preload function of TIMx_CCDAT1 register. Supports write operations to TIMx_CCDAT1 register at any time, and the written value is effective immediately.</p> <p>1: Enable preload function of TIMx_CCDAT1 register. Only read and write operations to preload registers. When an update event occurs, the value of TIMx_CCDAT1 is loaded into the active register.</p> <p><i>Note 1: Only when TIMx_CTRL1.ONEPM = 1 (In one-pulse mode), PWM mode can be used without verifying the preload register, otherwise no other behavior can be predicted.</i></p>  |

| Bit field | Name        | Description   |
|-----------|-------------|---|
| 2         | OC1FEN      | <p>Output Compare 1 fast enable</p> <p>This bit is used to speed up the response of the CC output to the trigger input event.</p> <p>0: CC1 behaves normally depending on the counter and CCDAT1 values, even if the trigger is ON. The minimum delay for activating CC1 output when an edge occurs on the trigger input is 5 clock cycles.</p> <p>1: An active edge of the trigger input acts like a comparison match on CC1 output. Therefore, OC is set to the comparison level regardless of the comparison result. The delay time for sampling the trigger input and activating the CC1 output is reduced to 3 clock cycles.</p> <p>OCxFEN only works if the channel is configured in PWM1 or PWM2 mode.</p> |
| 1: 0      | CC1SEL[1:0] | <p>Capture/compare 1 selection</p> <p>These bits are used to select the input/output and input mapping of the channel</p> <p>00: CC1 channel is configured as output</p> <p>01: CC1 channel is configured as input, IC1 is mapped on TI1</p> <p>10: CC1 channel is configured as input, IC1 is mapped on TI2</p> <p>11: CC1 channels are configured as inputs and IC1 is mapped to TRC. This mode is only active when the internal trigger input is selected by TIMx_SMCTRL.TSEL.</p> <p><i>Note: CC1SEL is writable only when the channel is off (TIMx_CCEN.CC1EN = 0).</i></p>  |

#### Input capture mode:

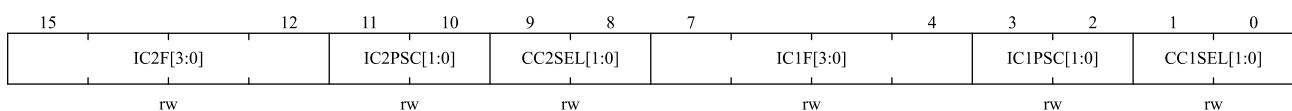

| Bit field | Name        | Description  |
|-----------|-------------|--|
| 15:12     | IC2F[3:0]   | Input Capture 2 Filter   |
| 11:10     | IC2PSC[1:0] | Input Capture 2 Prescaler  |
| 9:8       | CC2SEL[1:0] | <p>Capture/Compare 2 selection</p> <p>These bits are used to select the input/output and input mapping of the channel</p> <p>00: CC2 channel is configured as output</p> <p>01: CC2 channel is configured as input, IC2 is mapped on TI2</p> <p>10: CC2 channel is configured as input, IC2 is mapped on TI1</p> <p>11: CC2 channel is configured as input, IC2 is mapped on TRC. This mode is only active when the internal trigger input is selected by TIMx_SMCTRL.TSEL.</p> <p><i>Note: CC2SEL is writable only when the channel is off (TIMx_CCEN.CC2EN = 0).</i></p> |
| 7:4       | IC1F[3:0]   | <p>Input Capture 1 filter</p> <p>These bits are used to define sampling frequency of TI1 input and the length of digital filter. The digital filter is an event counter that generates an output transition after N events are recorded.</p> <p>0000: No filter, sampling at f<sub>DTS</sub> frequency</p> <p>0001: f<sub>SAMPLING</sub> = f<sub>CK_INT</sub>, N = 2</p> <p>0010: f<sub>SAMPLING</sub> = f<sub>CK_INT</sub>, N = 4</p> <p>0011: f<sub>SAMPLING</sub> = f<sub>CK_INT</sub>, N = 8</p> <p>0100: f<sub>SAMPLING</sub> = f<sub>DTS</sub>/2, N = 6</p>          |

| Bit field | Name        | Description   |
|-----------|-------------|---|
|           |             | 0101: $f_{\text{SAMPLING}} = f_{\text{DTS}}/2, N = 8$<br>0110: $f_{\text{SAMPLING}} = f_{\text{DTS}}/4, N = 6$<br>0111: $f_{\text{SAMPLING}} = f_{\text{DTS}}/4, N = 8$<br>1000: $f_{\text{SAMPLING}} = f_{\text{DTS}}/8, N = 6$<br>1001: $f_{\text{SAMPLING}} = f_{\text{DTS}}/8, N = 8$<br>1010: $f_{\text{SAMPLING}} = f_{\text{DTS}}/16, N = 5$<br>1011: $f_{\text{SAMPLING}} = f_{\text{DTS}}/16, N = 6$<br>1100: $f_{\text{SAMPLING}} = f_{\text{DTS}}/16, N = 8$<br>1101: $f_{\text{SAMPLING}} = f_{\text{DTS}}/32, N = 5$<br>1110: $f_{\text{SAMPLING}} = f_{\text{DTS}}/32, N = 6$<br>1111: $f_{\text{SAMPLING}} = f_{\text{DTS}}/32, N = 8$ |
| 3:2       | IC1PSC[1:0] | Input Capture 1 prescaler<br>These bits are used to select the ratio of the prescaler for IC1 (CC1 input).<br>When $\text{TIMx\_CCEN.CC1EN} = 0$ , the prescaler will be reset.<br>00: No prescaler, capture is done each time an edge is detected on the capture input<br>01: Capture is done once every 2 events<br>10: Capture is done once every 4 events<br>11: Capture is done once every 8 events  |
| 1:0       | CC1SEL[1:0] | Capture/Compare 1 selection<br>These bits are used to select the input/output and input mapping of the channel<br>00: CC1 channel is configured as output<br>01: CC1 channel is configured as input, IC1 is mapped on TI1<br>10: CC1 channel is configured as input, IC1 is mapped on TI2<br>11: CC1 channel is configured as input, IC1 is mapped to TRC. This mode is only active when the internal trigger input is selected by $\text{TIMx\_SMCTRL.TSEL}$ .<br><i>Note: CC1SEL is writable only when the channel is off (<math>\text{TIMx\_CCEN.CC1EN} = 0</math>).</i>   |

### 11.4.9 Capture/compare mode register 2 (TIMx\_CCMOD2)

Offset address: 0x1C

Reset value: 0x0000

See the description of the CCMOD1 register above

Output comparison mode:

|        |            |    |        |        |             |   |        |            |   |        |        |             |   |
|--------|------------|----|--------|--------|-------------|---|--------|------------|---|--------|--------|-------------|---|
| 15     | 14         | 12 | 11     | 10     | 9           | 8 | 7      | 6          | 4 | 3      | 2      | 1           | 0 |
| OC4CEN | OC4MD[2:0] |    | OC4PEN | OC4FEN | CC4SEL[1:0] |   | OC3CEN | OC3MD[2:0] |   | OC3PEN | OC3FEN | CC3SEL[1:0] |   |
| rw     | rw         |    | rw     | rw     | rw          |   | rw     | rw         |   | rw     | rw     | rw          |   |

| Bit field | Name       | Description                     |
|-----------|------------|---------------------------------|
| 15        | OC4CEN     | Output compare 4 clear enable   |
| 14:12     | OC4MD[2:0] | Output compare 4 mode           |
| 11        | OC4PEN     | Output compare 4 preload enable |
| 10        | OC4FEN     | Output compare 4 fast enable    |

| Bit field | Name        | Description   |
|-----------|-------------|---|
| 9:8       | CC4SEL[1:0] | Capture/Compare 4 selection<br>These bits are used to select the input/output and input mapping of the channel<br>00: CC4 channel is configured as output<br>01: CC4 channel is configured as input, IC4 is mapped on TI4<br>10: CC4 channel is configured as input, IC4 is mapped on TI3<br>11: CC4 channel is configured as input, IC4 is mapped on TRC. This mode is only active when the internal trigger input is selected by TIMx_SMCTRL.TSEL.<br><i>Note: CC4SEL is writable only when the channel is off (TIMx_CCEN.CC4EN = 0).</i> |
| 7         | OC3CEN      | Output compare 3 clear enable   |
| 6:4       | OC3MD[2:0]  | Output compare 3 mode   |
| 3         | OC3PEN      | Output compare 3 preload enable   |
| 2         | OC3FEN      | Output compare 3 fast enable  |
| 1:0       | CC3SEL[1:0] | Capture/Compare 3 selection<br>These bits are used to select the input/output and input mapping of the channel<br>00: CC3 channel is configured as output<br>01: CC3 channel is configured as input, IC3 is mapped to TI3<br>10: CC3 channel is configured as input, IC3 is mapped on TI4<br>11: CC3 channel is configured as input, IC3 is mapped to TRC. This mode is only active when the internal trigger input is selected by TIMx_SMCTRL.TSEL.<br><i>Note: CC3SEL is writable only when the channel is off (TIMx_CCEN.CC3EN = 0).</i> |

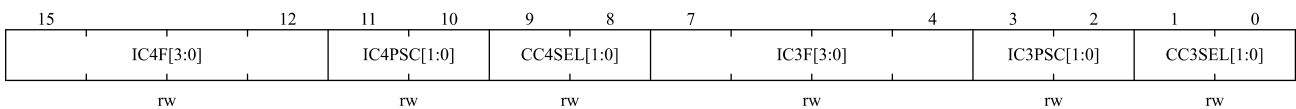
**Input capture mode:**

| Bit field | Name        | Description   |
|-----------|-------------|---|
| 15:12     | IC4F[3:0]   | Input Capture 4 filter  |
| 11:10     | IC4PSC[1:0] | Input Capture 4 Prescaler   |
| 9:8       | CC4SEL[1:0] | Capture/Compare 4 selection<br>These bits are used to select the input/output and input mapping of the channel<br>00: CC4 channel is configured as output<br>01: CC4 channel is configured as input, IC4 is mapped on TI4<br>10: CC4 channel is configured as input, IC4 is mapped on TI3<br>11: CC4 channel is configured as input, IC4 is mapped on TRC. This mode is only active when the internal trigger input is selected by TIMx_SMCTRL.TSEL.<br><i>Note: CC4SEL is writable only when the channel is off (TIMx_CCEN.CC4EN = 0).</i> |
| 7:4       | IC3F[3:0]   | Input Capture 3 filter  |
| 3:2       | IC3PSC[1:0] | Input Capture 3 Prescaler   |

| Bit field | Name        | Description   |
|-----------|-------------|---|
| 1:0       | CC3SEL[1:0] | Capture/compare 3 selection<br>These bits are used to select the input/output and input mapping of the channel<br>00: CC3 channel is configured as output<br>01: CC3 channel is configured as input, IC3 is mapped to TI3<br>10: CC3 channel is configured as input, IC3 is mapped on TI4<br>11: CC3 channel is configured as input, IC3 is mapped to TRC. This mode is only active when the internal trigger input is selected by TIMx_SMCTRL.TSEL.<br><i>Note: CC3SEL is writable only when the channel is off (TIMx_CCEN.CC3EN = 0).</i> |

### 11.4.10 Capture/compare enable registers (TIMx\_CCEN)

Offset address: 0x20

Reset value: 0x0000 0000

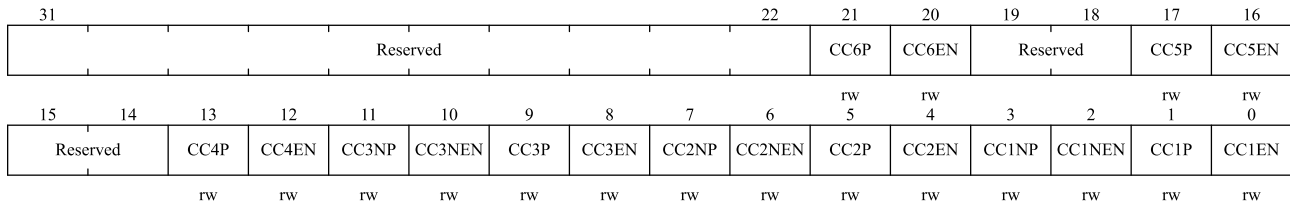

| Bit field | Name     | Description   |
|-----------|----------|---|
| 31:22     | Reserved | Reserved, the reset value must be maintained  |
| 21        | CC6P     | Capture/Compare 6 output polarity<br>See TIMx_CCEN.CC1P description.                |
| 20        | CC6EN    | Capture/Compare 6 output enable<br>See TIMx_CCEN.CC1EN description.                 |
| 19: 18    | Reserved | Reserved, the reset value must be maintained  |
| 17        | CC5P     | Capture/Compare 5 output polarity<br>See TIMx_CCEN.CC1P description.                |
| 16        | CC5EN    | Capture/Compare 5 output enable<br>See TIMx_CCEN.CC1EN description.                 |
| 15:14     | Reserved | Reserved, the reset value must be maintained  |
| 13        | CC4P     | Capture/Compare 4 output polarity<br>See TIMx_CCEN.CC1P description.                |
| 12        | CC4EN    | Capture/Compare 4 output enable<br>See TIMx_CCEN.CC1EN description.                 |
| 11        | CC3NP    | Capture/Compare 3 Complementary output polarity<br>See TIMx_CCEN.CC1NP description. |
| 10        | CC3NEN   | Capture/Compare 3 complementary output enable<br>See TIMx_CCEN.CC1NEN description.  |
| 9         | CC3P     | Capture/Compare 3 output polarity   |

| Bit field | Name   | Description   |
|-----------|--------|---|
|           |        | See TIM <sub>x</sub> _CCEN.CC1P description.  |
| 8         | CC3EN  | Capture/Compare 3 output enable<br>See TIM <sub>x</sub> _CCEN.CC1EN description.  |
| 7         | CC2NP  | Capture/Compare 2 complementary output polarity<br>See TIM <sub>x</sub> _CCEN.CC1NP description.  |
| 6         | CC2NEN | Capture/Compare 2 complementary output enable<br>See TIM <sub>x</sub> _CCEN.CC1NEN description.   |
| 5         | CC2P   | Capture/Compare 2 output polarity<br>See TIM <sub>x</sub> _CCEN.CC1P description.   |
| 4         | CC2EN  | Capture/Compare 2 output enable<br>See TIM <sub>x</sub> _CCEN.CC1EN description.  |
| 3         | CC1NP  | Capture/Compare 1 complementary output polarity<br>0: OC1N active high<br>1: OC1N active low  |
| 2         | CC1NEN | Capture/Compare 1 complementary output enable<br>0: Disable - Disable output OC1N signal. The level of OC1N depends on the value of these bits TIM <sub>x</sub> _BKDT.MOEN, TIM <sub>x</sub> _BKDT.OSSI, TIM <sub>x</sub> _BKDT.OSSR, TIM <sub>x</sub> _CTRL2.OI1, TIM <sub>x</sub> _CTRL2.OI1N and TIM <sub>x</sub> _CCEN.CC1EN.<br>1: Enable - Enable output OC1N signal. The level of OC1N depends on the value of these bits TIM <sub>x</sub> _BKDT.MOEN, TIM <sub>x</sub> _BKDT.OSSI, TIM <sub>x</sub> _BKDT.OSSR, TIM <sub>x</sub> _CTRL2.OI1, TIM <sub>x</sub> _CTRL2.OI1N and TIM <sub>x</sub> _CCEN.CC1EN.   |
| 1         | CC1P   | Capture/Compare 1 output polarity<br>When the corresponding channel of CC1 is in output mode:<br>0: OC1 active high<br>1: OC1 active low<br>When the corresponding channel of CC1 is in input mode:<br>At this time, this bit is used to select whether IC1 or the inverse signal of IC1 is used as the trigger or capture signal.<br>0: non-inverted: Capture action occurs when IC1 generates a rising edge. When used as external trigger, IC1 is non-inverted.<br>1: inverted: Capture action occurs when IC1 generates a falling edge. When used as external trigger, IC1 is inverted.   |
| 0         | CC1EN  | Capture/Compare 1 output enable<br>When the corresponding channel of CC1 is in output mode:<br>0: Disable - Disable output OC1 signal. The level of OC1 depends on the value of these bits TIM <sub>x</sub> _BKDT.MOEN, TIM <sub>x</sub> _BKDT.OSSI, TIM <sub>x</sub> _BKDT.OSSR, TIM <sub>x</sub> _CTRL2.OI1, TIM <sub>x</sub> _CTRL2.OI1N and TIM <sub>x</sub> _CCEN.CC1NEN.<br>1: Enable - Enable output OC1 signal. The level of OC1N depends on the value of these bits TIM <sub>x</sub> _BKDT.MOEN, TIM <sub>x</sub> _BKDT.OSSI, TIM <sub>x</sub> _BKDT.OSSR, TIM <sub>x</sub> _CTRL2.OI1, TIM <sub>x</sub> _CTRL2.OI1N and TIM <sub>x</sub> _CCEN.CC1NEN.<br>When the corresponding channel of CC1 is in input mode:<br>At this time, this bit is used to disable/enable the capture function. |

| Bit field | Name | Description                             |
|-----------|------|---|
|           |      | 0: Disable capture<br>1: Enable capture |

Table 11-4 Output control bits of complementary OCx and OCxN channels with break function

| Control bits |      |      |       |        | Output state <sup>1)</sup>  |   |
|--------------|------|------|-------|--------|---|---|
| MOEN         | OSSI | OSSR | CCxEN | CCxNEN | OCx Output state  | OCxN Output state   |
| 1            | X    | 0    | 0     | 0      | Output disabled (not driven by timer)<br>OCx=0, OCx_EN=0                            | Output disabled (not driven by timer)<br>OCxN=0, OCxN_EN=0              |
|              |      | 0    | 0     | 1      | Output disabled (not driven by timer)<br>OCx=0, OCx_EN=0                            | OCxREF + polarity,<br>OCxN= OCxREF xor CCxNP, OCxN_EN=1                 |
|              |      | 0    | 1     | 0      | OCxREF + polarity,<br>OCx= OCxREF xor CCxP, OCx_EN=1                                | Output disabled (not driven by timer)<br>OCxN=0, OCxN_EN=0              |
|              |      | 0    | 1     | 1      | OCxREF + polarity + dead-time,<br>OCx_EN=1  | Complementary to OCxREF + polarity + dead-time,<br>OCxN_EN=1            |
|              |      | 1    | 0     | 0      | Output disabled (not driven by timer)<br>OCx=CCxP, OCx_EN=0                         | Output disabled (not driven by timer)<br>OCxN=CCxNP, OCxN_EN=0          |
|              |      | 1    | 0     | 1      | Off-state (Output enabled with inactive state)<br>OCx=CCxP, OCx_EN=1                | OCxREF + polarity,<br>OCxN= OCxREF xor CCxNP, OCxN_EN=1                 |
|              |      | 1    | 1     | 0      | OCxREF + polarity,<br>OCx= OCxREF xor CCxP, OCx_EN=1                                | Off-state (Output enabled with inactive state)<br>OCxN=CCxNP, OCxN_EN=1 |
|              |      | 1    | 1     | 1      | OCxREF + polarity + dead-time,<br>OCx_EN=1  | Complementary to OCxREF + polarity + dead-time,<br>OCxN_EN=1            |
| 0            | X    | 0    | 0     | 0      | Output disabled (not driven by timer)   |   |
|              |      | 0    | 0     | 1      | Asynchronously: OCx=CCxP, OCx_EN=0, OCxN=CCxNP, OCxN_EN=0;                          |   |
|              |      | 0    | 1     | 0      | Then if the clock is present: OCx=OIx and OCxN=OIxN after a dead-time, when (CCxP ^ |   |
|              |      | 0    | 1     | 1      | OIx) ^ (CCxNP ^ OIxN) != 0.   |   |
|              |      | 1    | 0     | 0      | Off-state (Output enabled with inactive state)                                      |   |
|              |      | 1    | 0     | 1      | Asynchronously: OCx=CCxP, OCx_EN=1, OCxN=CCxNP, OCxN_EN=1;                          |   |
|              |      | 1    | 1     | 0      | Then if the clock is present: OCx=OIx and OCxN=OIxN after a dead-time, when (CCxP ^ |   |
|              |      | 1    | 1     | 1      | OIx) ^ (CCxNP ^ OIxN) != 0  |   |

1. If both outputs of a channel are not used (CCxEN = CCxNEN = 0), OIx, OIxN, CCxP and CCxNP must all be cleared.

Note: The status of external I/O pins connected to complementary OCx and OCxN channels depends on the OCx and OCxN channel states and GPIO and AFIO registers.

### 11.4.11 Counters (TIMx\_CNT)

Offset address: 0x24

Reset value: 0x0000

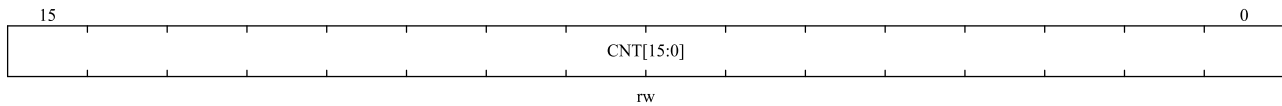

| Bit field | Name      | Description   |
|-----------|-----------|---------------|
| 15:0      | CNT[15:0] | Counter value |

### 11.4.12 Prescaler (TIMx\_PSC)

Offset address: 0x28

Reset value: 0x0000

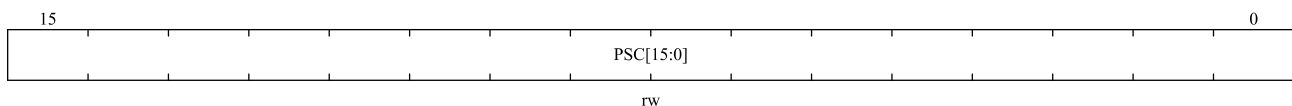

| Bit field | Name      | Description  |
|-----------|-----------|--|
| 15:0      | PSC[15:0] | Prescaler value<br>Counter clock $f_{CK\_CNT} = f_{CK\_PSC} / (PSC [15:0] + 1)$ .<br>Each time an update event occurs, the PSC value is loaded into the active prescaler register. |

### 11.4.13 Auto-reload register (TIMx\_AR)

Offset address: 0x2C

Reset values: 0xFFFF

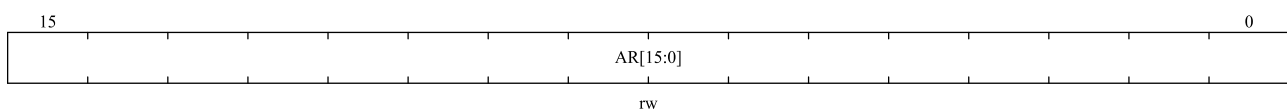

| Bit field | Name     | Description  |
|-----------|----------|--|
| 15:0      | AR[15:0] | Auto-reload value<br>These bits define the value that will be loaded into the actual auto-reload register.<br>See Section 11.3.1 for more details.<br>When the TIMx_AR.AR [15:0] value is null, the counter does not work. |

### 11.4.14 Repeat count registers (TIMx\_REPCNT)

Offset address: 0x30

Reset value: 0x0000

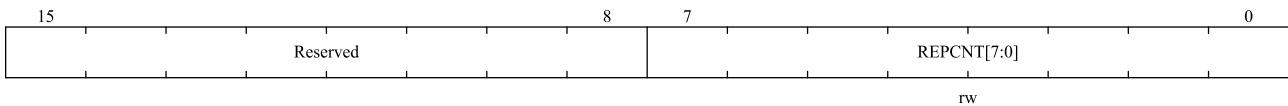

| Bit field | Name        | Description  |
|-----------|-------------|--|
| 15:8      | Reserved    | Reserved, the reset value must be maintained   |
| 7:0       | REPCNT[7:0] | Repetition counter value<br>Repetition counter is used to generate the update event or update the timer registers only after a given number (N+1) cycles of the counter, where N is the value of TIMx_REPCNT.REPCNT . The repetition counter is decremented at each counter overflow in up-counting mode, at each counter underflow in down-counting mode or at each counter overflow and at each counter underflow in center-aligned mode. Setting the TIMx_EVTGEN.UDGN bit will reload the content of TIMx_REPCNT.REPCNT and generate an update event. |

### 11.4.15 Capture/compare register 1 (TIMx\_CC DAT1)

Offset address: 0x34

Reset value: 0x0000

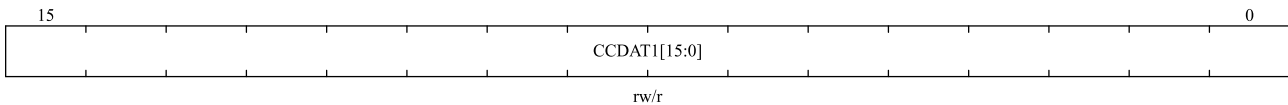

| Bit field | Name          | Description  |
|-----------|---------------|--|
| 15:0      | CC DAT1[15:0] | Capture/Compare 1 value<br><ul style="list-style-type: none"> <li>■ CC1 channel is configured as output:<br/>CC DAT1 contains the value to be compared to the counter TIMx_CNT, signaling on the OC1 output.<br/>If the preload feature is not selected in TIMx_CCMOD1.OC1PEN bit, the written value is immediately transferred to the active register. Otherwise, this preloaded value is transferred to the active register only when an update event occurs.</li> <li>■ CC1 channel is configured as input:<br/>CC DAT1 contains the counter value transferred by the last input capture 1 event (IC1).<br/>When configured as input mode, register CC DAT1 and CC DDAT1 are only readable.<br/>When configured as output mode, register CC DAT1 and CC DDAT1 are readable and writable.</li> </ul> |

### 11.4.16 Capture/compare register 2 (TIMx\_CC DAT2)

Offset address: 0x38

Reset value: 0x0000

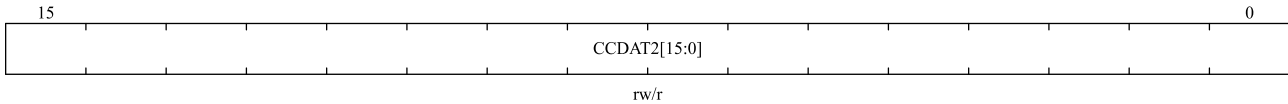

| Bit field | Name         | Description   |
|-----------|--------------|---|
| 15:0      | CCDAT2[15:0] | <p>Capture/Compare 2 values</p> <ul style="list-style-type: none"> <li>CC2 channel is configured as output:<br/>CCDAT2 contains the value to be compared to the counter TIMx_CNT, signaling on the OC2 output.<br/>If the preload feature is not selected in TIMx_CCMOD1.OC2PEN bit, the written value is immediately transferred to the active register. Otherwise, this preloaded value is transferred to the active register only when an update event occurs.</li> <li>CC2 channel is configured as input:<br/>CCDAT2 contains the counter value transferred by the last input capture 2 event (IC2).<br/>When configured as input mode, register CCDAT2 and CCDDAT2 are only readable.<br/>When configured as output mode, register CCDAT2 and CCDDAT2 are readable and writable.</li> </ul> |

### 11.4.17 Capture/compare register 3 (TIMx\_CCDAT3)

Offset address: 0x3C

Reset value: 0x0000

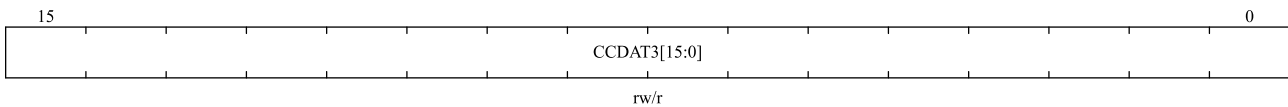

| Bit field | Name         | Description  |
|-----------|--------------|--|
| 15:0      | CCDAT3[15:0] | <p>Capture/Compare 3 value</p> <ul style="list-style-type: none"> <li>CC3 channel is configured as output:<br/>CCDAT3 contains the value to be compared to the counter TIMx_CNT, signaling on the OC3 output.<br/>If the preload feature is not selected in TIMx_CCMOD2.OC3PEN bit, the written value is immediately transferred to the active register. Otherwise, this preloaded value is transferred to the active register only when an update event occurs.</li> <li>CC3 channel is configured as input:<br/>CCDAT3 contains the counter value transferred by the last input capture 3 event (IC3).<br/>When configured as input mode, register CCDAT3 and CCDDAT3 are only readable.<br/>When configured as output mode, register CCDAT3 and CCDDAT3 are readable and writable.</li> </ul> |

### 11.4.18 Capture/compare register 4 (TIMx\_CCDAT4)

Offset address: 0x40

Reset value: 0x0000

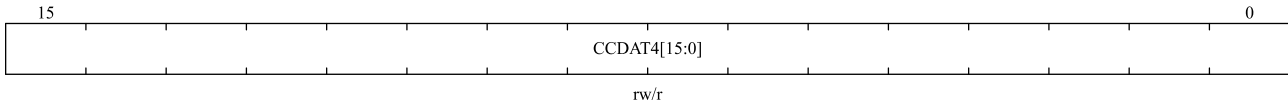

| Bit field | Name         | Description   |
|-----------|--------------|---|
| 15:0      | CCDAT4[15:0] | Capture/Compare 4 value <ul style="list-style-type: none"> <li>■ CC4 channel is configured as output:<br/>CCDAT4 contains the value to be compared to the counter TIMx_CNT, signaling on the OC4 output.<br/>If the preload feature is not selected in TIMx_CCMOD2.OC4PEN bit, the written value is immediately transferred to the active register. Otherwise, this preloaded value is transferred to the active register only when an update event occurs.</li> <li>■ CC4 channel is configured as input:<br/>CCDAT4 contains the counter value transferred by the last input capture 4 event (IC4).<br/>When configured as input mode, register CCDAT4 and CCDDAT4 are only readable.<br/>When configured as output mode, register CCDAT4 and CCDDAT4 are readable and writable.</li> </ul> |

### 11.4.19 Break and Dead-time registers (TIMx\_BKDT)

Offset address: 0x44

Reset value: 0x0000

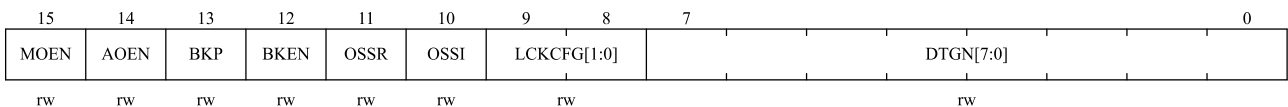

*Note:* AOEN, BKP, BKEN, OSSI, OSSR, and DTGN [7:0] bits can all be write protected depending on the LOCK configuration, and it is necessary to configure all of them on the first write to the TIMx\_BKDT register.

| Bit field | Name | Description  |
|-----------|------|--|
| 15        | MOEN | Main Output enable<br>This bit can be set by software or hardware depending on the TIMx_BKDT.AOEN bit, and is asynchronously cleared to '0' by hardware once the brake input is active. It is only valid for channels configured as outputs.<br>0: OC and OCN outputs are disabled or forced to idle state.<br>1: OC and OCN outputs are enabled if TIMx_CCEN.CCxEN or TIMx_CCEN.CCxNEN bits are set.<br>For more details, see Section 11.4.10 Capture/Compare enable registers (TIMx_CCEN). |
| 14        | AOEN | Automatic output enable<br>0: Only software can set TIMx_BKDT.MOEN;<br>1: Software sets TIMx_BKDT.MOEN; or if the brake input is not active, when the next update event occurs, hardware automatically sets TIMx_BKDT.MOEN.  |
| 13        | BKP  | Break input polarity<br>0: Low level of the brake input is valid<br>1: High level of the brake input is valid  |

| Bit field | Name        | Description   |
|-----------|-------------|---|
|           |             | <i>Note: Any write to this bit requires an APB clock delay to take effect.</i>  |
| 12        | BKEN        | Break enable<br>0: Disable brake input (BRK and CCS clock failure events)<br>1: Enable brake input (BRK and CCS clock failure events)<br><i>Note: Any write to this bit requires an APB clock delay to take effect.</i>   |
| 11        | OSSR        | Off-state Selection for Run Mode<br>This bit is used when TIMx_BKDT.MOEN=1 and the channel is a complementary output.<br>The OSSR bit does not exist in timer without complementary outputs.<br>0: When inactive, OCx/OCxN outputs are disabled (OCx/OCxN enable output signal=0).<br>1: When inactive, OCx/OCxN outputs are enabled with their inactive level as soon as CCxEN=1 or CCxNEN=1. Then, OCx/OCxN enable output signal=1<br>For more details, See Section 11.4.10, capture/compare enablement registers (TIMx_CCEN).  |
| 10        | OSSI        | Off-state Selection for Idle Mode<br>This bit is used when TIMx_BKDT.MOEN=0 and the channels configured as outputs.<br>0: When inactive, OCx/OCxN outputs are disabled (OCx/OCxN enable output signal=0).<br>1: When inactive, OCx/OCxN outputs are enabled with their idle level as soon as CCxEN=1 or CCxNEN=1. Then, OCx/OCxN enable output signal=1<br>For more details, See Section 11.4.10, capture/compare enablement registers (TIMx_CCEN).   |
| 9:8       | LCKCFG[1:0] | Lock Configuration<br>These bits offer a write protection against software errors.<br>00:<br>– No write protected.<br>01:<br>– LOCK Level 1<br>TIMx_BKDT.DTGN, TIMx_BKDT.BKEN, TIMx_BKDT.BKP, TIMx_BKDT.AOEN, TIMx_CTRL2.OIx, TIMx_CTRL2.OIxN bits enable write protection.<br>10:<br>– LOCK Level 2<br>Except for register write protection in LOCK Level 1 mode, TIMx_CCEN.CCxP and TIMx_CCEN.CCxNP (If the corresponding channel is configured in output mode), TIMx_BKDT.OSSR and TIMx_BKDT.OSSI bits also enable write protection.<br>11:<br>– LOCK Level 3<br>Except for register write protection in LOCK Level 2, TIMx_CCMODx.OCxMD and TIMx_CCMODx.OCxPEN bits (If the corresponding channel is configured in output mode) also enable write protection.<br><i>Note: After the system reset, the LCKCFG bit can only be written once. Once written to the TIMx_BKDT register, LCKCFG will be protected until the next reset.</i> |

| Bit field | Name       | Description  |
|-----------|------------|--|
| 7:0       | DTGN [7:0] | Dead-time Generator<br>These bits define the dead-time duration between inserted complementary outputs. The relationship between the DTGN value and the dead time is as follows:<br>DTGN[7:5] = 0xx:<br>$dead\ time = DTGN[7:0] \times (t_{DTS})$<br>DTGN[7:5] = 10x:<br>$dead\ time = (64 + DTGN[5:0]) \times (2 \times t_{DTS})$<br>DTGN[7:5]=110:<br>$dead\ time = (32 + DTGN[4:0]) \times (8 \times t_{DTS})$<br>DTGN [then] = 111:<br>$dead\ time = (32 + DTGN [4:0]) \times (16 \times t_{DTS})$<br>$t_{DTS}$ value see TIMx_CTRL1.CLKD [1:0]. |

### 11.4.20 DMA Control register (TIMx\_DCTRL)

Offset address: 0x48

Reset value: 0x0000

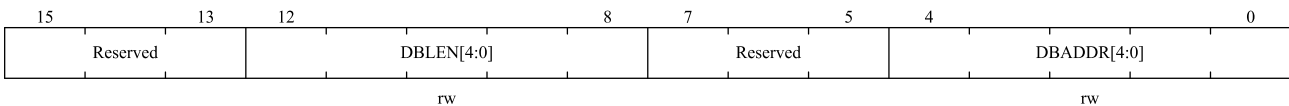

| Bit field | Name        | Description  |
|-----------|-------------|--|
| 15:9      | Reserved    | Reserved, the reset value must be maintained, kept at 0.   |
| 12:8      | DBLEN[4:0]  | DMA Burst Length<br>This bit field defines the number DMA will accesses (write/read) TIMx_DADDR register.<br>00000: 1 time transfer<br>00001: 2 times transfers<br>00010: 3 times transfers<br>...<br>10001: 18 times transfers  |
| 7:5       | Reserved    | Reserved, the reset value must be maintained.  |
| 4:0       | DBADDR[4:0] | DMA Base Address<br>This bit field defines the first address where the DMA accesses the TIMx_DADDR register.<br>When access is done through the TIMx_DADDR first time, this bit-field specifies the address you just access. And then the second access to the TIMx_DADDR, you will access the address of "DMA Base Address + 4"<br>00000: TIMx_CTRL1,<br>00001: TIMx_CTRL2,<br>00010: TIMx_SMCTRL,<br>...<br>10001: TIMx_BKDT |

| Bit field | Name | Description       |
|-----------|------|-------------------|
|           |      | 10010: TIMx_DCTRL |

### 11.4.21 DMA transfer buffer register (TIMx\_DADDR)

Offset address: 0x4C

Reset value: 0x0000

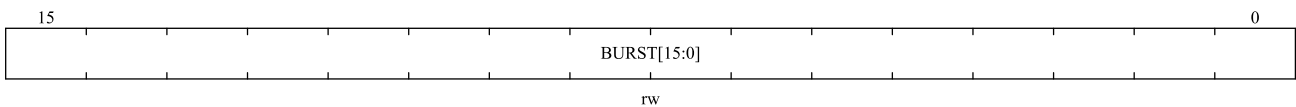

| Bit field | Name        | Description  |
|-----------|-------------|--|
| 15:0      | BURST[15:0] | <p>DMA access buffer.</p> <p>When a read or write operation is assigned to this register, the register located at the address range (DMA base address + DMA burst length × 4) will be accessed.</p> <p>DMA base address = The address of TIMx_CTRL1 + TIMx_DCTRL.DBADDR * 4;</p> <p>DMA burst len = TIMx_DCTRL.DBLEN + 1.</p> <p>Example:</p> <p>If TIMx_DCTRL.DBLEN = 0x3(4 transfers), TIMx_DCTRL.DBADDR = 0xD (TIMx_CC DAT1), DMA data length = half word, DMA memory address = buffer address in SRAM, DMA peripheral address = TIMx_DADDR address.</p> <p>When an event occurs, TIMx will send requests to the DMA, and transfer data 4 times.</p> <p>For the first time, DMA access to the TIMx_DADDR register will be mapped to access TIMx_CC DAT1 register;</p> <p>For the second time, DMA access to the TIMx_DADDR register will be mapped to access TIMx_CC DAT2 register;</p> <p>... ..</p> <p>For the fourth time, DMA access to the TIMx_DADDR register will be mapped to access TIMx_CC DAT4 register;</p> |

### 11.4.22 Capture/compare mode registers 3(TIMx\_CCMOD3)

Offset address: 0x54

Reset value: 0x0000

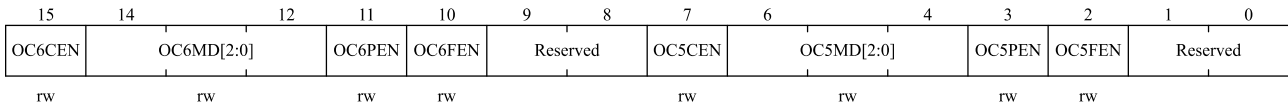

| Bit field | Name       | Description                                  |
|-----------|------------|--|
| 15        | OC6CEN     | Output compare 6 clear enable                |
| 14:12     | OC6MD[2:0] | Output compare 6 mode                        |
| 11        | OC6PEN     | Output compare 6 preload enable              |
| 10        | OC6FEN     | Output compare 6 fast enable                 |
| 9:8       | Reserved   | Reserved, the reset value must be maintained |
| 7         | OC5CEN     | Output compare 5 clear enable                |
| 6:4       | OC5MD[2:0] | Output compare 5 mode                        |
| 3         | OC5PEN     | Output compare 5 Preload enable              |
| 2         | OC5FEN     | Output compare 5 fast enable                 |
| 1: 0      | Reserved   | Reserved, the reset value must be maintained |

### 11.4.23 Capture/compare register 5 (TIMx\_CC DAT5)

Offset address: 0x58

Reset value: 0x0000

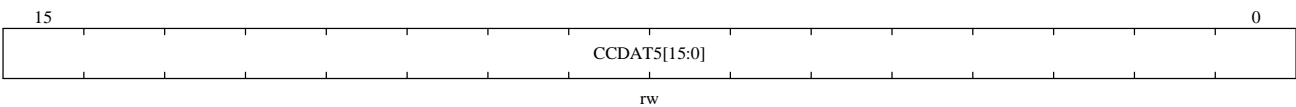

| Bit field | Name         | Description   |
|-----------|--------------|---|
| 15:0      | CCDAT5[15:0] | Capture/Compare 5 value<br>■ CC5 channel can only configured as output:<br>CCDAT5 contains the value to be compared to the counter TIMx_CNT, signaling on the OC5 output.<br>If the preload feature is not selected in TIMx_CCMOD3_OC5PEN bit, the written value is immediately transferred to the active register. Otherwise, this preloaded value is transferred to the active register only when an update event occurs.<br>TIM1_CC5 and TIM8_CC5 is used for comparator blanking. |

### 11.4.24 Capture/compare register 6 (TIMx\_CC DAT6)

Offset address: 0x5C

Reset value: 0x0000

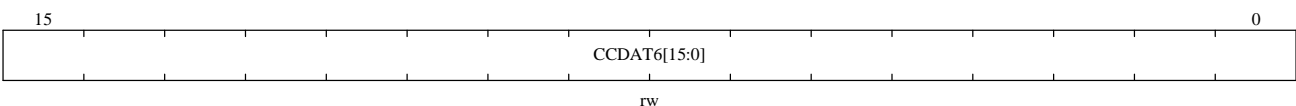

| Bit field | Name         | Description   |
|-----------|--------------|---|
| 15:0      | CCDAT6[15:0] | <p>Capture/Compare 6 value</p> <ul style="list-style-type: none"><li>■ CC6 channel can only configured as output:</li></ul> <p>CCDAT6 contains the value to be compared to the counter TIMx_CNT, signaling on the OC6 output.</p> <p>If the preload feature is not selected in TIMx_CCMOD3.OC6PEN bit, the written value is immediately transferred to the active register. Otherwise, this preloaded value is transferred to the active register only when an update event occurs.</p> <p>TIM1_CC6 is used to switch the input channel of OPAMP1 and OPAMP2; TIM8_CC6 is used to switch the input channel of OPAMP3 and OPAMP4</p> |

## 12 General-purpose timers (TIM2, TIM3, TIM4 and TIM5)

### 12.1 General-purpose timers introduction

The general-purpose timers (TIM2, TIM3, TIM4 and TIM5) is mainly used in the following occasions: counting the input signal, measuring the pulse width of the input signal and generating the output waveform, etc.

### 12.2 Main features of General-purpose timers

- 16-bit auto-reload counters. (It can realize up-counting, down-counting, up/down counting)
- 16-bit programmable prescaler. (The frequency division factor can be configured with any value between 1 and 65536)
- TIM2, TIM3, TIM4 and TIM5 up to 4 channels.
- Channel's working modes: PWM output, output compare, one-pulse mode output, input capture.
- The events that generate the interrupt/DMA are as follows:
  - ◆ Update event
  - ◆ Trigger event
  - ◆ Input capture
  - ◆ Output compare
- Timer can be controlled by external signal
- Timers can be linked together internally for timer synchronization or chaining
- Incremental (quadrature) encoder interface: used for tracking motion and resolving rotation direction and position;
- Hall sensor interface: used to do three-phase motor control;
- Supports capture of internal comparator output signal.

Figure 12-1 Block diagram of TIMx (x=2, 3, 4 and 5)

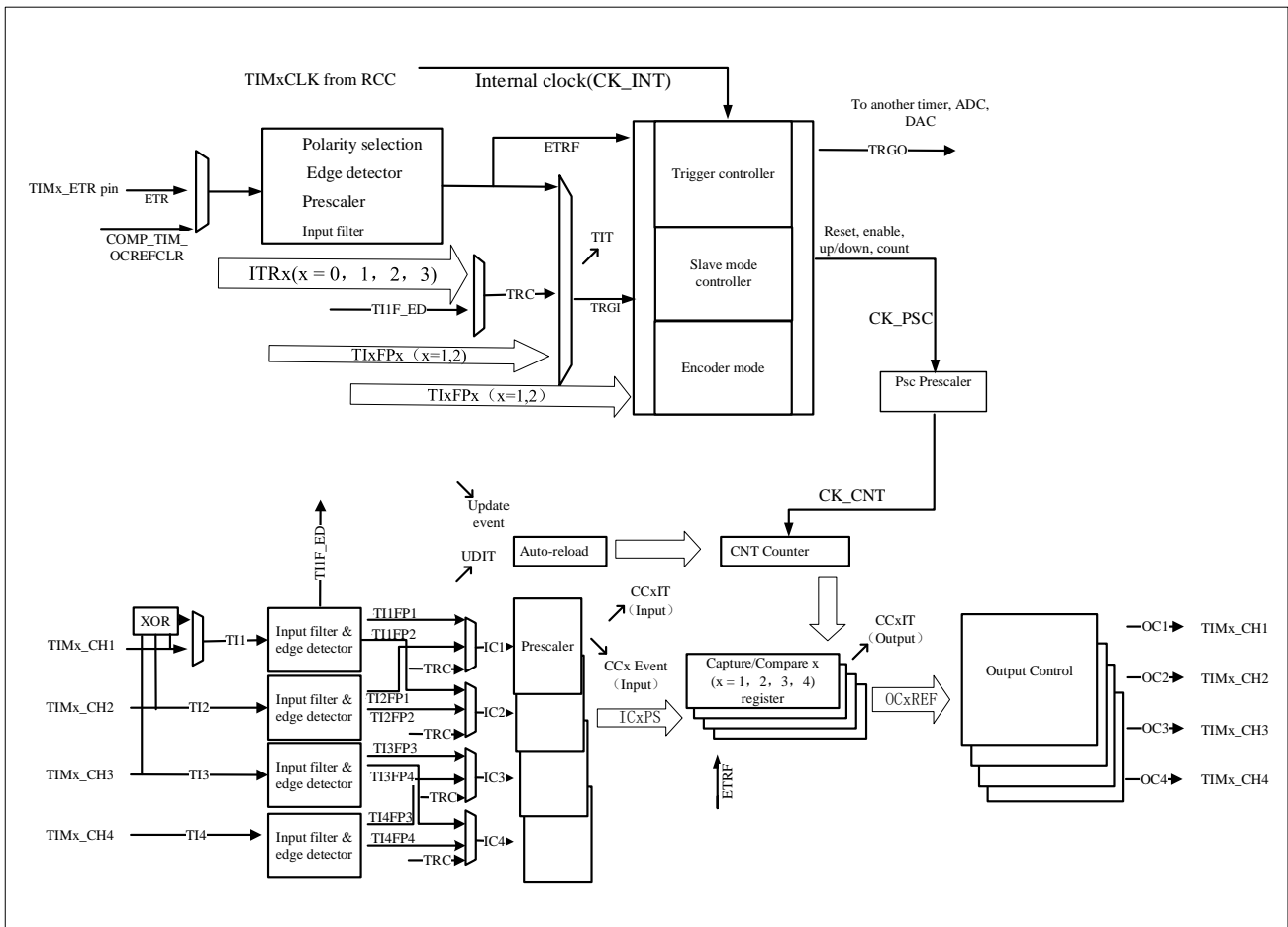

↘ The event

↗ Interrupt and DMA output

The capture channel 1/2/3/4 input can come from IOM or comparator output, except CH4 of TIM5 (Only from IOM)

For the mapping of ETR input to IOM, see 7.2.5.7

## 12.3 General-purpose timers description

### 12.3.1 Time-base unit

The time-base unit mainly includes: prescaler, counter and auto-reload. When the time base unit is working, the software can read and write the corresponding registers (**TIMx\_PSC**, **TIMx\_CNT** and **TIMx\_AR**) at any time.

Depending on the setting of the auto-reload preload enable bit (**TIMx\_CTRL1.ARPEN**), the value of the preload register is transferred to the shadow register immediately or at each update event UEV. An update event is generated when the counter reaches the overflow/underflow condition and it can be generated by software when **TIMx\_CTRL1.UPDIS=0**. The counter **CK\_CNT** is valid only when the **TIMx\_CTRL1.CNTEN** bit is set. The counter starts counting one clock cycle after the **TIMx\_CTRL1.CNTEN** bit is set.

#### 12.3.1.1 Prescaler description

The **TIMx\_PSC** register consists of a 16-bit counter that can be used to divide the counter clock frequency by any

factor between 1 and 65536. It can be changed on the fly as it is buffered. The prescaler value is only taken into account at the next update event.

Figure 12-2 Counter timing diagram with prescaler division change from 1 to 4

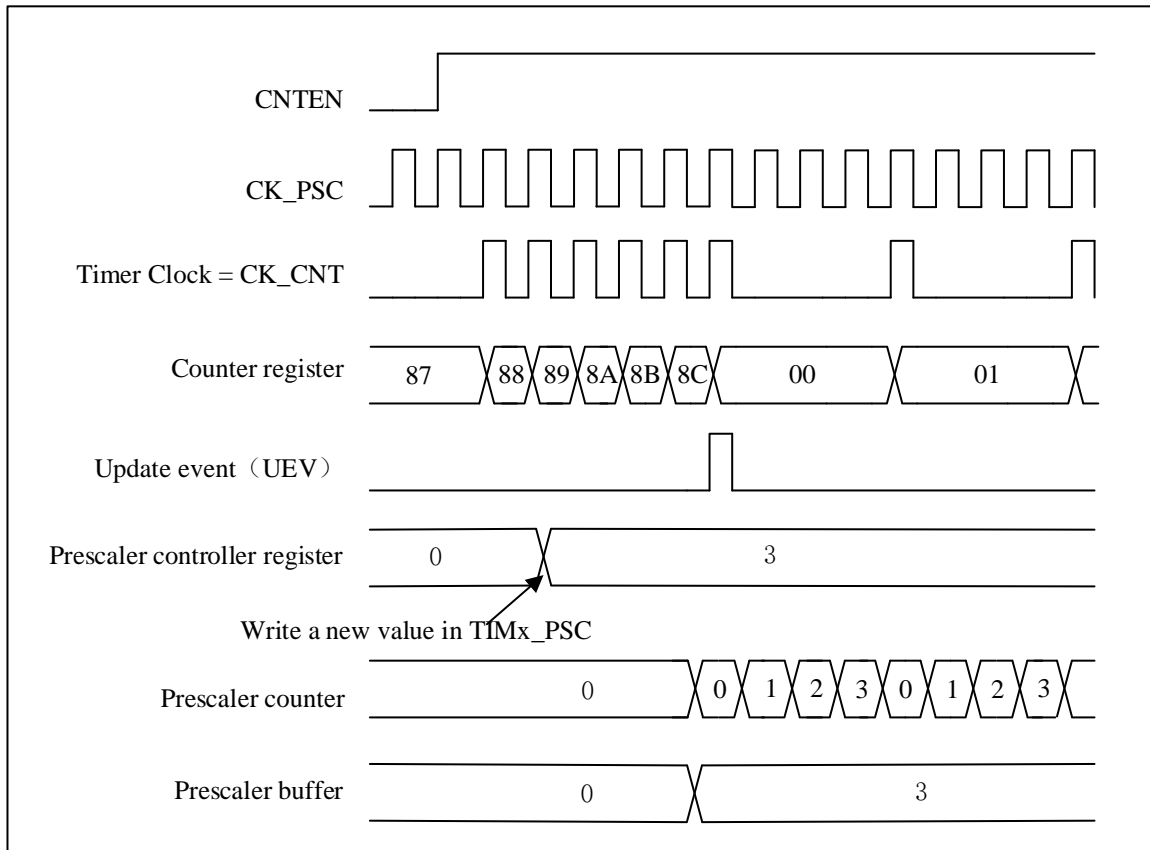

## 12.3.2 Counter mode

### 12.3.2.1 Up-counting mode

In up-counting mode, the counter will count from 0 to the value of the register TIMx\_AR, then it resets to 0. And a counter overflow event is generated.

If the TIMx\_CTRL1.UPRS bit (select update request) and the TIMx\_EVTGEN.UDGN bit are set, an update event (UEV) will generate. And TIMx\_STS.UDITF will not be set by hardware, therefore, no update interrupts or update DMA requests are generated. This setting is used in scenarios where you want to clear the counter but do not want to generate an update interrupt.

Depending on the update request source is configured in the TIMx\_CTRL1.UPRS. When an update event occurs, TIMx\_STS.UDITF is set, all registers are updated:

- Update auto-reload shadow registers with preload value(TIMx\_AR), when TIMx\_CTRL1.ARPEN = 1.
- The prescaler shadow register is reloaded with the preload value(TIMx\_PSC).

To avoid updating the shadow registers when new values are written to the preload registers, you can disable the update by setting TIMx\_CTRL1.UPDIS=1.

When an update event occurs, the counter will still be cleared and the prescaler counter will also be set to 0 (but the

prescaler value will remain unchanged).

The figure below shows some examples of the counter behavior and the update flags for different division factors in the up-counting mode.

Figure 12-3 Timing diagram of up-counting. The internal clock divider factor = 2/N

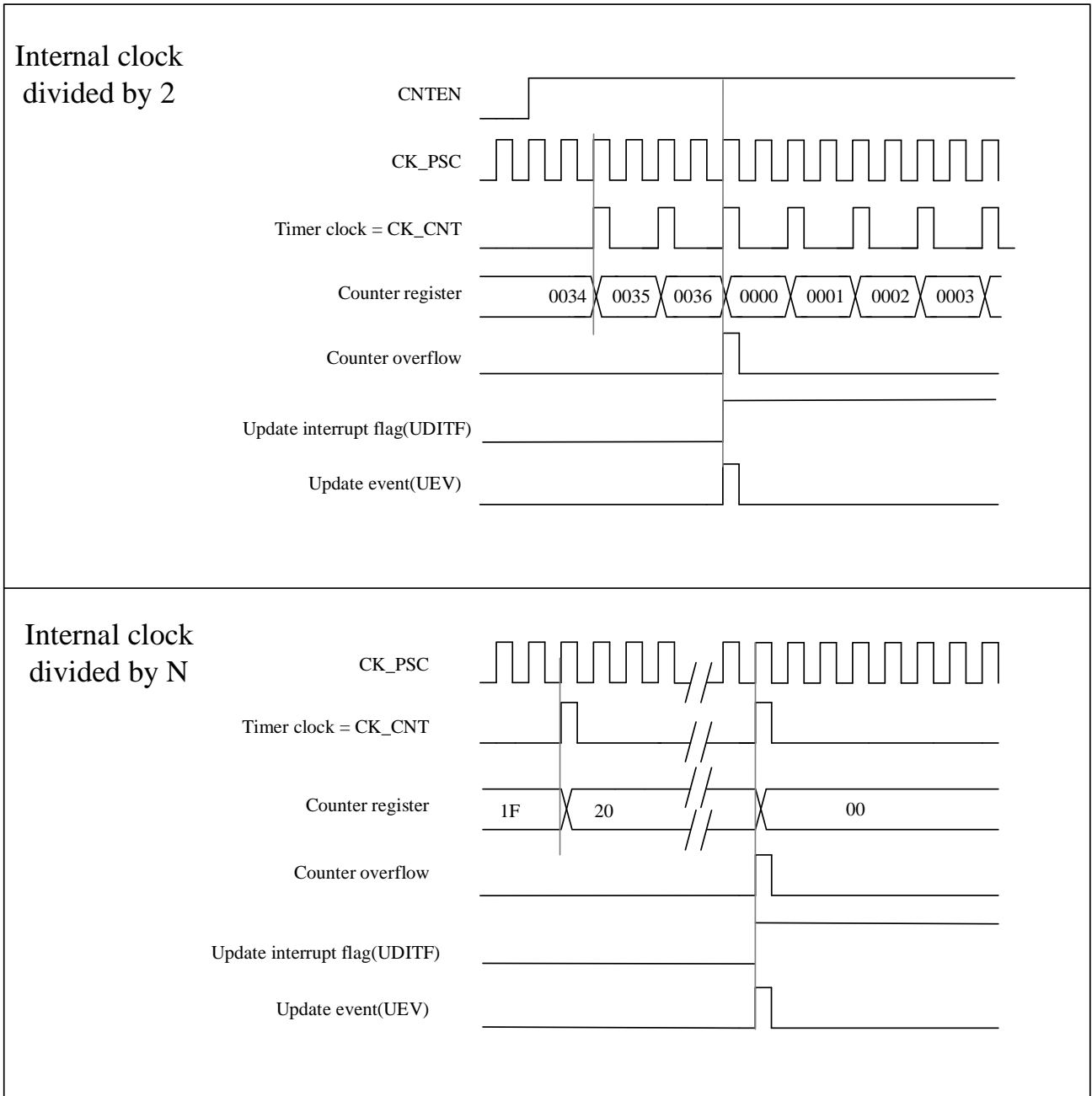
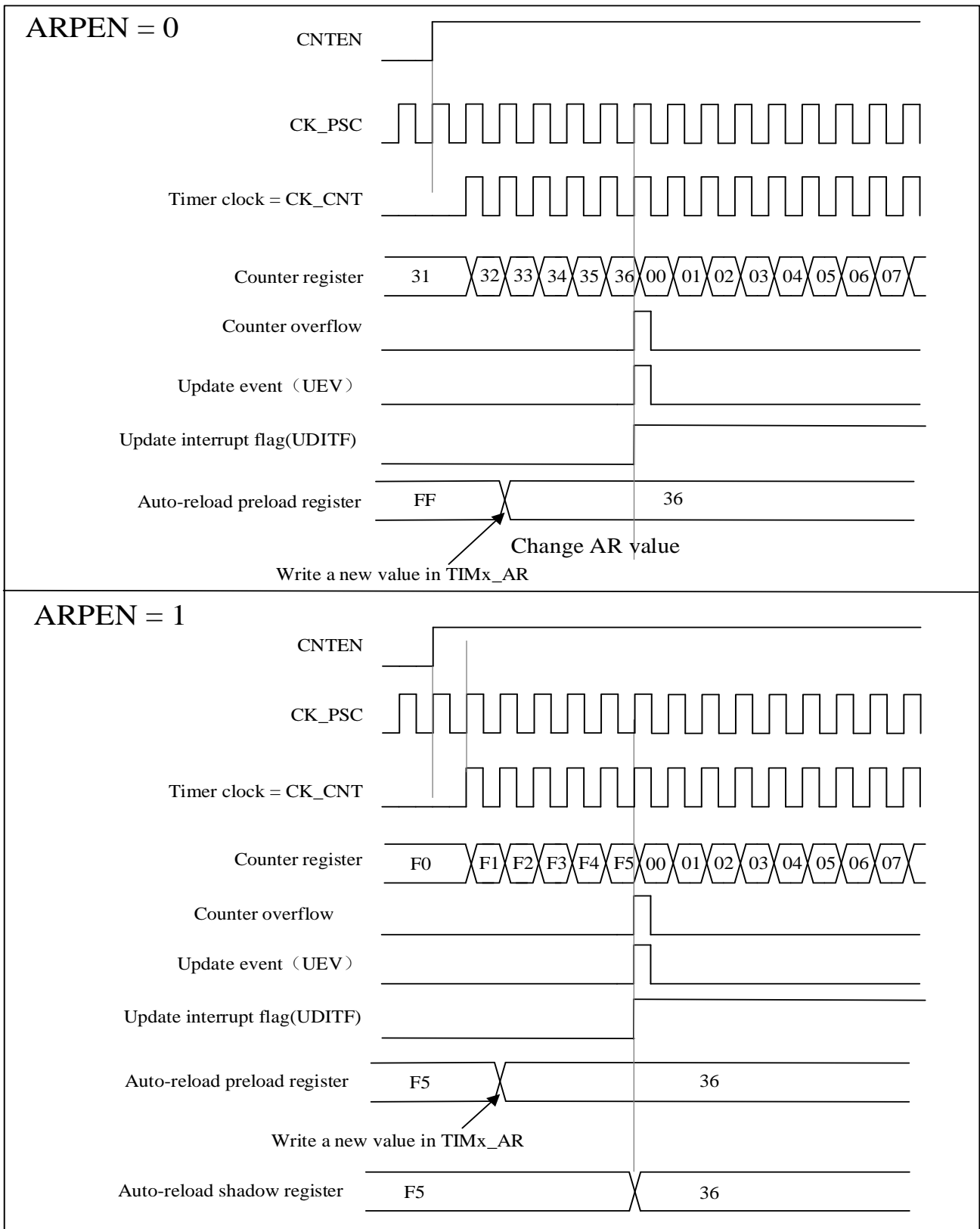

Figure 12-4 Timing diagram of the up-counting, update event when ARPEN=0/1



### 12.3.2.2 Down-counting mode

In down-counting mode, the counter will decrement from the value of the register TIMx\_AR to 0, then restart from the auto-reload value and generate a counter underflow event.

The process of configuring update events and updating registers in down-counting mode is the same as in up-counting mode, see 12.3.2.1.

The figure below shows some examples of the counter behavior and the update flags for different division factors in the down-counting mode.

Figure 12-5 Timing diagram of the down-counting, internal clock divided factor = 2/N

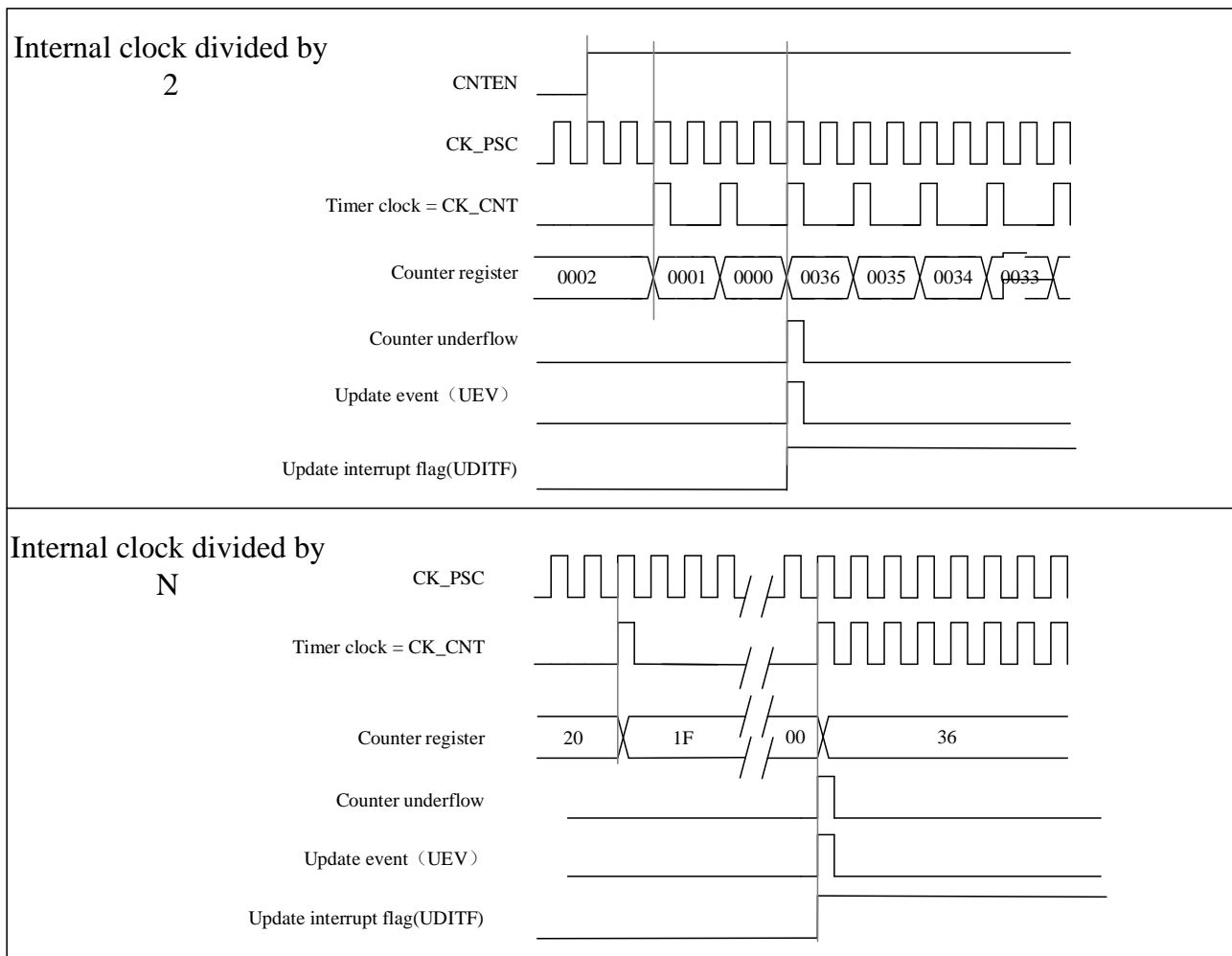

### 12.3.2.3 Center-aligned mode

In center-aligned mode, the counter increments from 0 to the value (TIMx\_AR) - 1, a counter overflow event is generated. It then counts down from the auto-reload value (TIMx\_AR) to 1 and generates a counter underflow event. Then the counter resets to 0 and starts counting up again.

In this mode, the TIMx\_CTRL1.DIR direction bits have no effect and the count direction is updated and specified by hardware. Center-aligned mode is valid when the TIMx\_CTRL1.CAMSEL bit is not equal to "00".

The update events can be generated each time the counter overflows and each time the counter underflows. Alternatively, an update event can also be generated by setting the TIMx\_EVTGEN.UDGN bit (either by software

or using a slave mode controller). In this case, the counter restarts from 0, as does the prescaler's counter.

Please note: if the update source is a counter overflow, auto-reload update before reloading the counter.

Figure 12-6 Timing diagram of the Center-aligned, internal clock divided factor =2/N

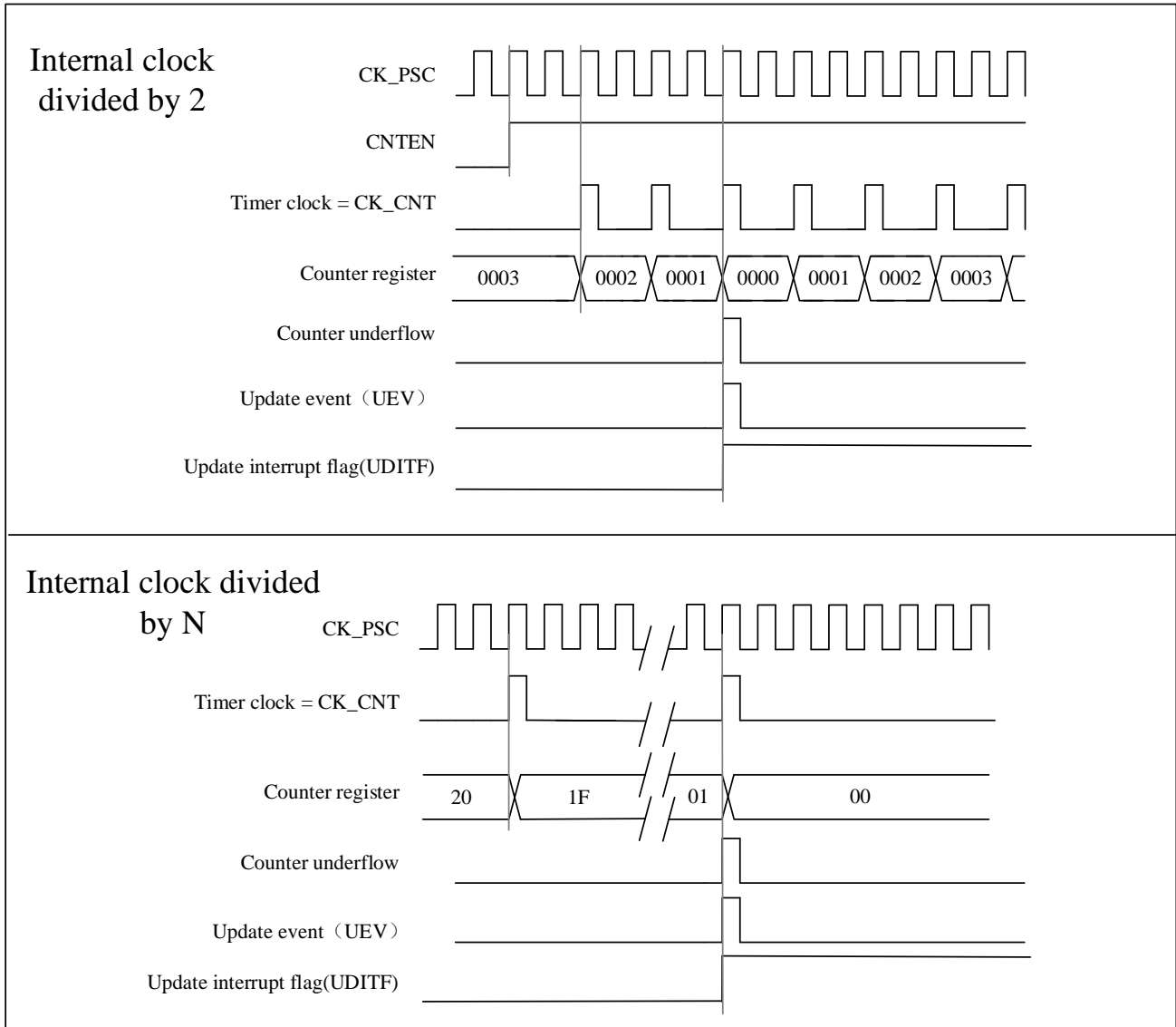
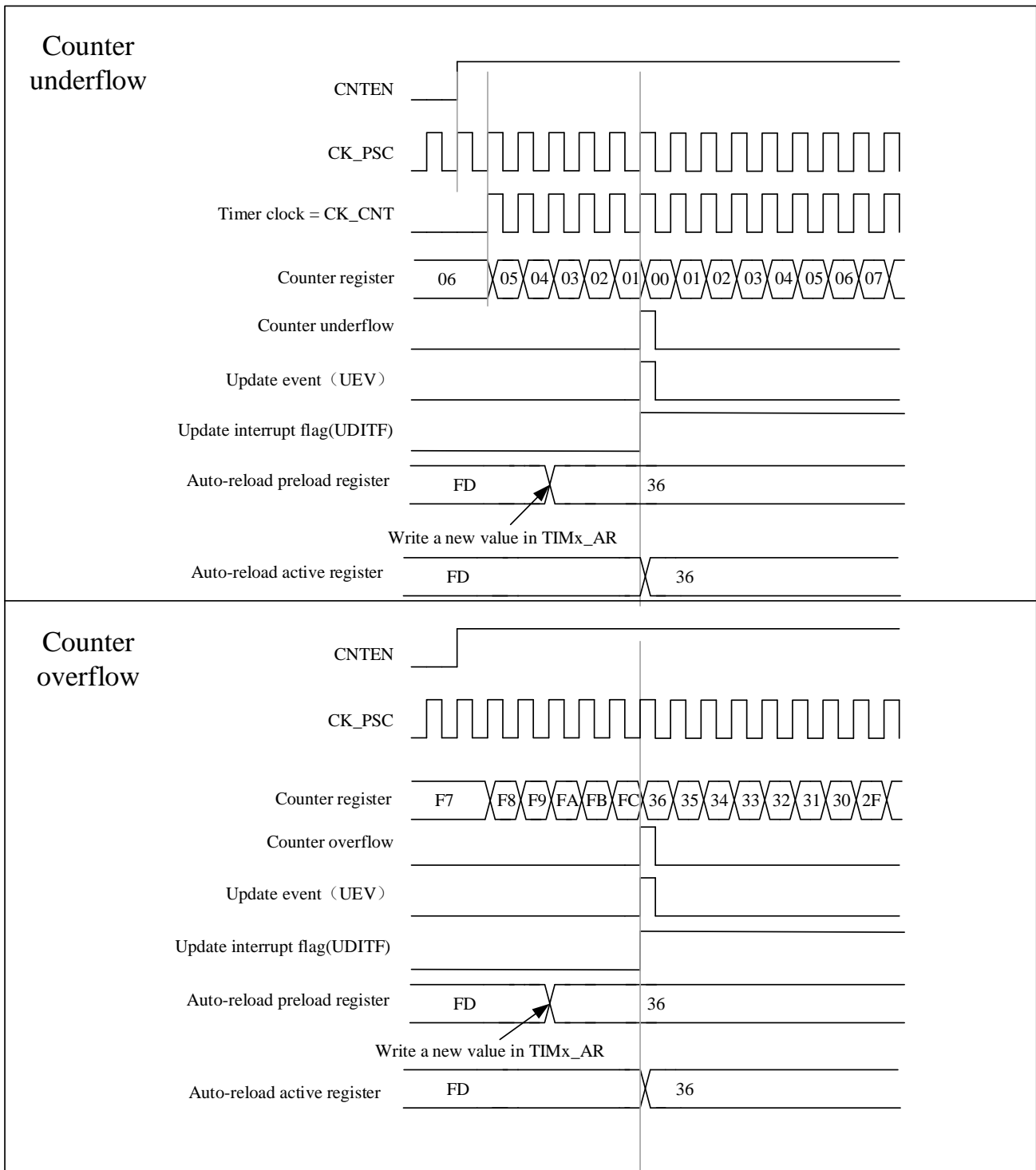

Figure 12-7 A center-aligned sequence diagram that includes counter overflows and underflows (ARPEN = 1)



### 12.3.3 Clock selection

- The internal clock of timers : CK\_INT
- Two kinds of external clock mode :
  - external input pin

- external trigger input ETR
- Internal trigger input (ITRx): one timer is used as a prescaler for another timer.

### 12.3.3.1 Internal clock source (CK\_INT)

When the TIMx\_SMCTRL.SMSEL is equal to “000”, the slave mode controller is disabled. The three control bits (TIMx\_CTRL1.CNTEN、TIMx\_CTRL1.DIR、TIMx\_EVTGEN.UDGN) can only be changed by software (except TIMx\_EVTGEN.UDGN, which remains cleared automatically). It is provided that the TIMx\_CTRL1.CNTEN bit is written as '1' by soft, the clock source of the prescaler is provided by the internal clock CK\_INT.

Figure 12-8 Control circuit in normal mode, internal clock divided by 1

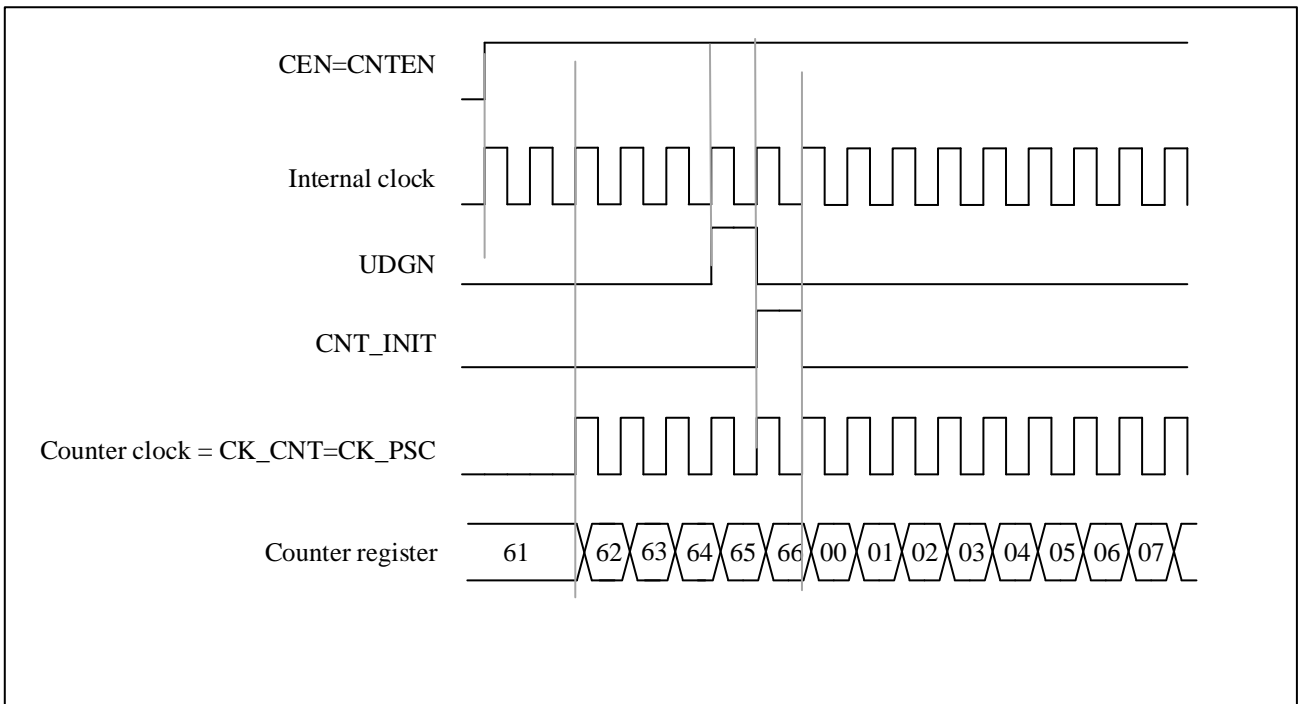

### 12.3.3.2 External clock source mode 1

Figure 12-9 TI2 external clock connection example

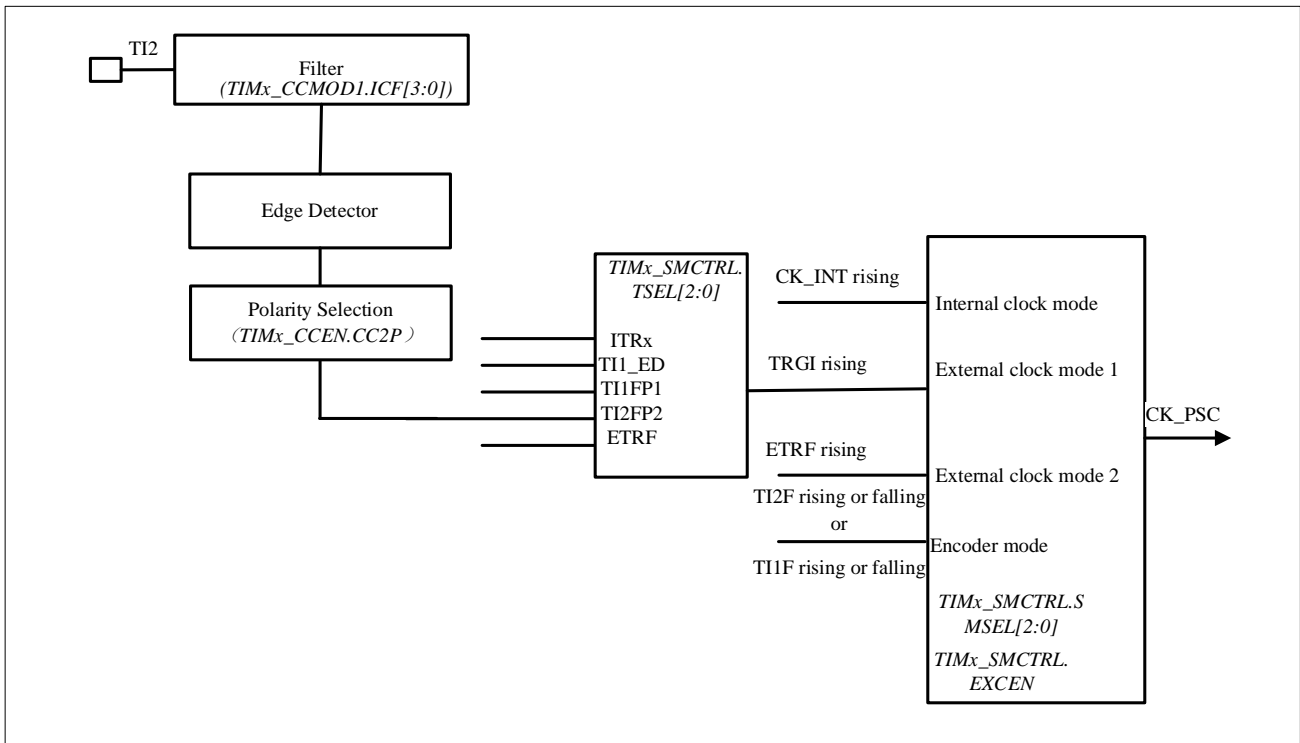

This mode is selected by configuring `TIMx_SMCTRL.SMSEL=111`. The counter can be configured to count on the rising or falling edge of the clock at the selected input.

For example, to configure up-counting mode to count on the rising edge of the clock at the TI2 input, the configuration steps are as follows:

- Configure `TIMx_CCMOD1.CC2SEL` equal to '01', CC2 channel is configured as input, IC2 is mapped to TI2
- Configure `TIMx_CCEN.CC2P` equal to '0', select clock rising edge polarity
- To select input filter bandwidth by configuring `TIMx_CCMOD1.IC2F[3:0]` (if filter is not needed, keep IC2F bit at '0000')
- Configure `TIMx_SMCTRL.SMSEL` equal to '111', select timer external clock mode 1
- Configure `TIMx_SMCTRL.TSEL` equal to '110', select TI2 as the trigger input source
- Configure `TIMx_CTRL1.CNTEN` equal to '1' to start the counter

*Note: The capture prescaler is not used for triggering, so it does not need to be configured*

When the rising edge of the timer clock occurs at `TI2=1`, the counter counts once and the `TIMx_STS.TITF` flag is pulled high.

The delay between the rising edge of TI2 and the actual clock of the counter depends on the resynchronization circuit at the input of TI2.

Figure 12-10 Control circuit in external clock mode 1

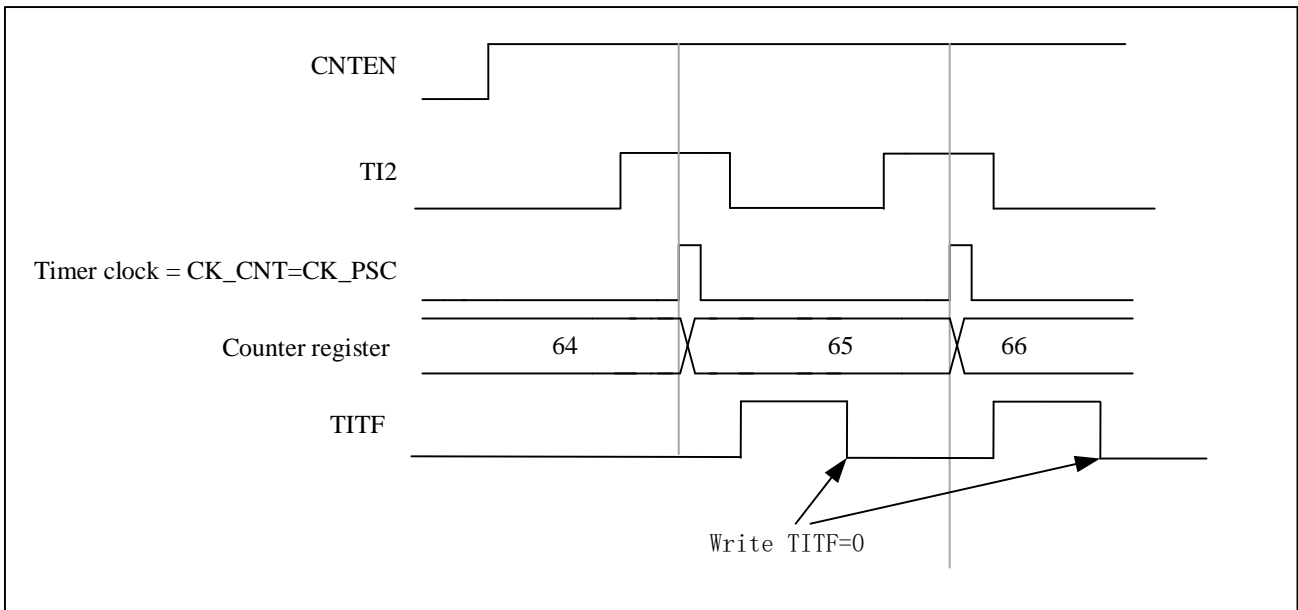

### 12.3.3.3 External clock source mode 2

This mode is selected by `TIMx_SMCTRL.EXCEN` equal to 1. The counter can count on every rising or falling edge of the external trigger input ETR.

The following figure is a schematic diagram of the external trigger input module in External clock source mode 2

Figure 12-11 External trigger input block diagram

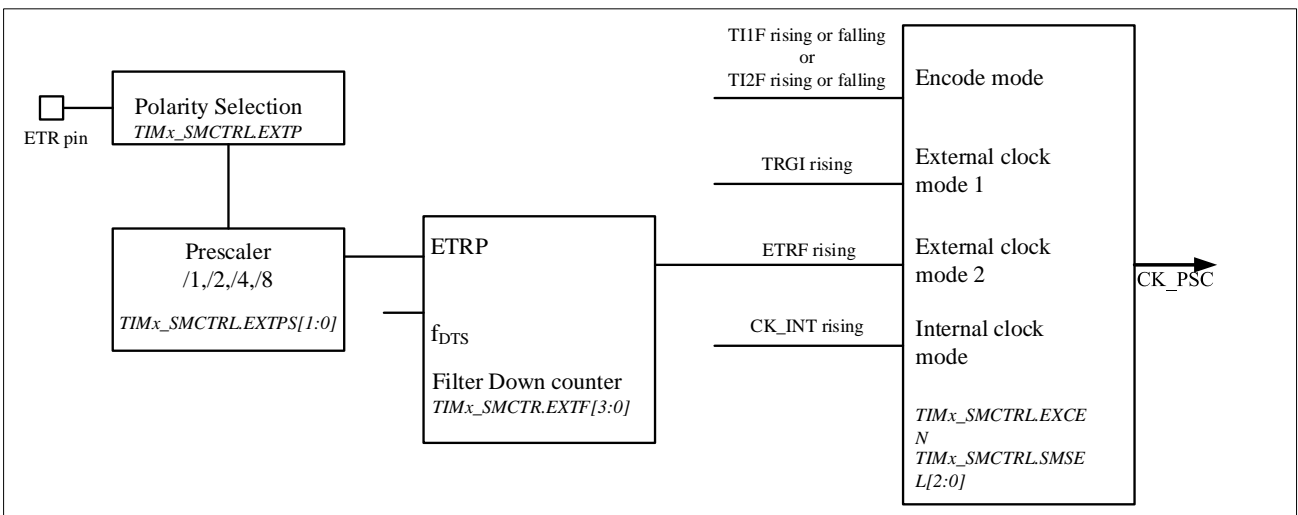

For example, use the following configuration steps to make the up counter count every 2 rising edges on ETR.

- Since no filter is needed in this case, make `TIMx_SMCTRL.EXTF[3:0]` equal to '0000'
- Configure the prescaler by making `TIMx_SMCTRL.EXTPS[1:0]` equal to '01'
- Select the polarity on ETR pin by setting `TIMx_SMCTRL.EXTP` equal to '0', The rising edge of ETR is valid
- External clock mode 2 is selected by setting `TIMx_SMCTRL.EXCEN` equal to '1'
- Turn on the counter by setting `TIMx_CTRL1.CNTEN` equal to '1'

The counter counts every 2 rising edges of ETR. The delay between the rising edge of ETR and the actual clock to the counter is due to a resynchronization circuit on the ETRP signal.

Figure 12-12 Control circuit in external clock mode 2

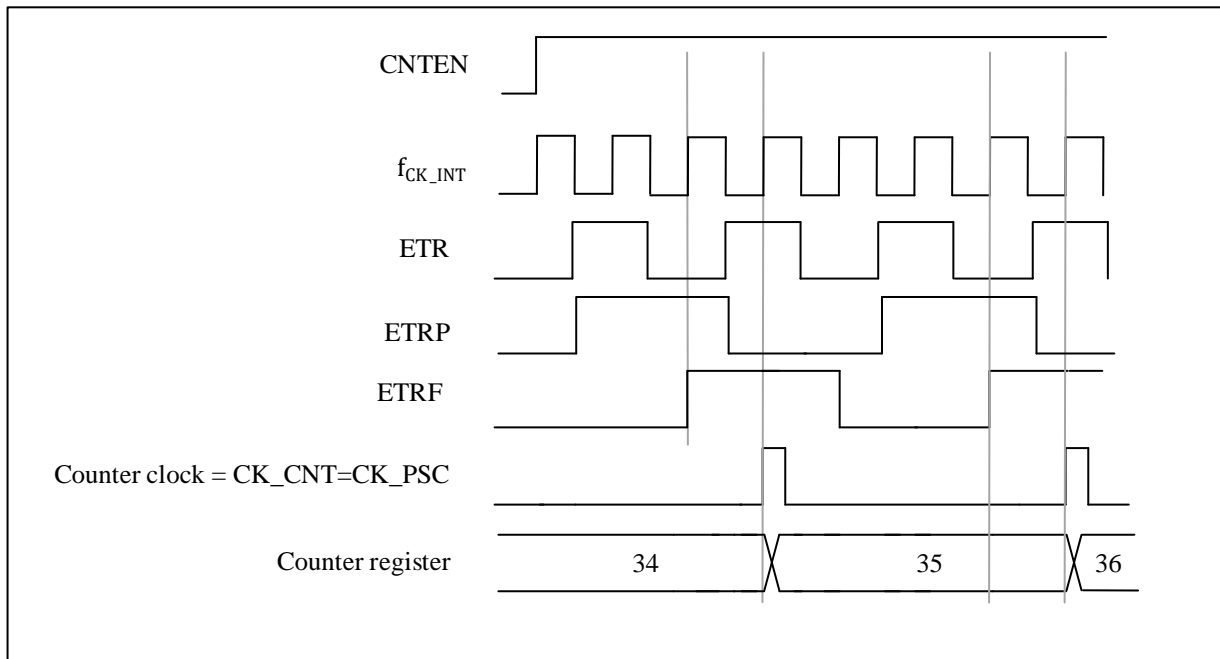

### 12.3.4 Capture/compare channels

Capture/compare channels include capture/compare registers and shadow registers. The input section consists of digital filters, multiplexers and prescalers. The output section includes comparators and output controls.

The input signal T<sub>Ix</sub> is sampled and filtered to generate the signal T<sub>IxF</sub>. A signal (T<sub>IxF</sub>\_rising or T<sub>IxF</sub>\_falling) is then generated by the edge detector of the polarity select function, the polarity of which is selected by the TIM<sub>x</sub>\_CCEN.CC<sub>x</sub>P bits. This signal can be used as a trigger input for the slave mode controller. At the same time, the signal IC<sub>x</sub> is sent to the capture register after frequency division. The following figure shows a block diagram of a capture/compare channel.

Figure 12-13 Capture/compare channel (example: channel 1 input stage)

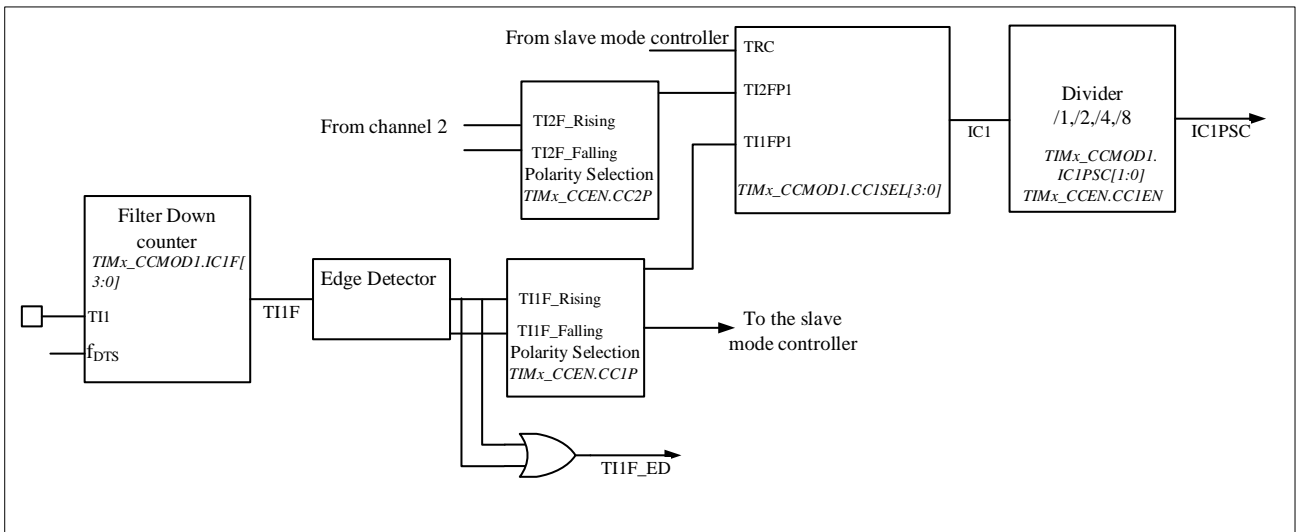

The output part generates an intermediate waveform  $OCxRef$  (active high) as reference. The polarity acts at the end of the chain.

Figure 12-14 Capture/compare channel 1 main circuit

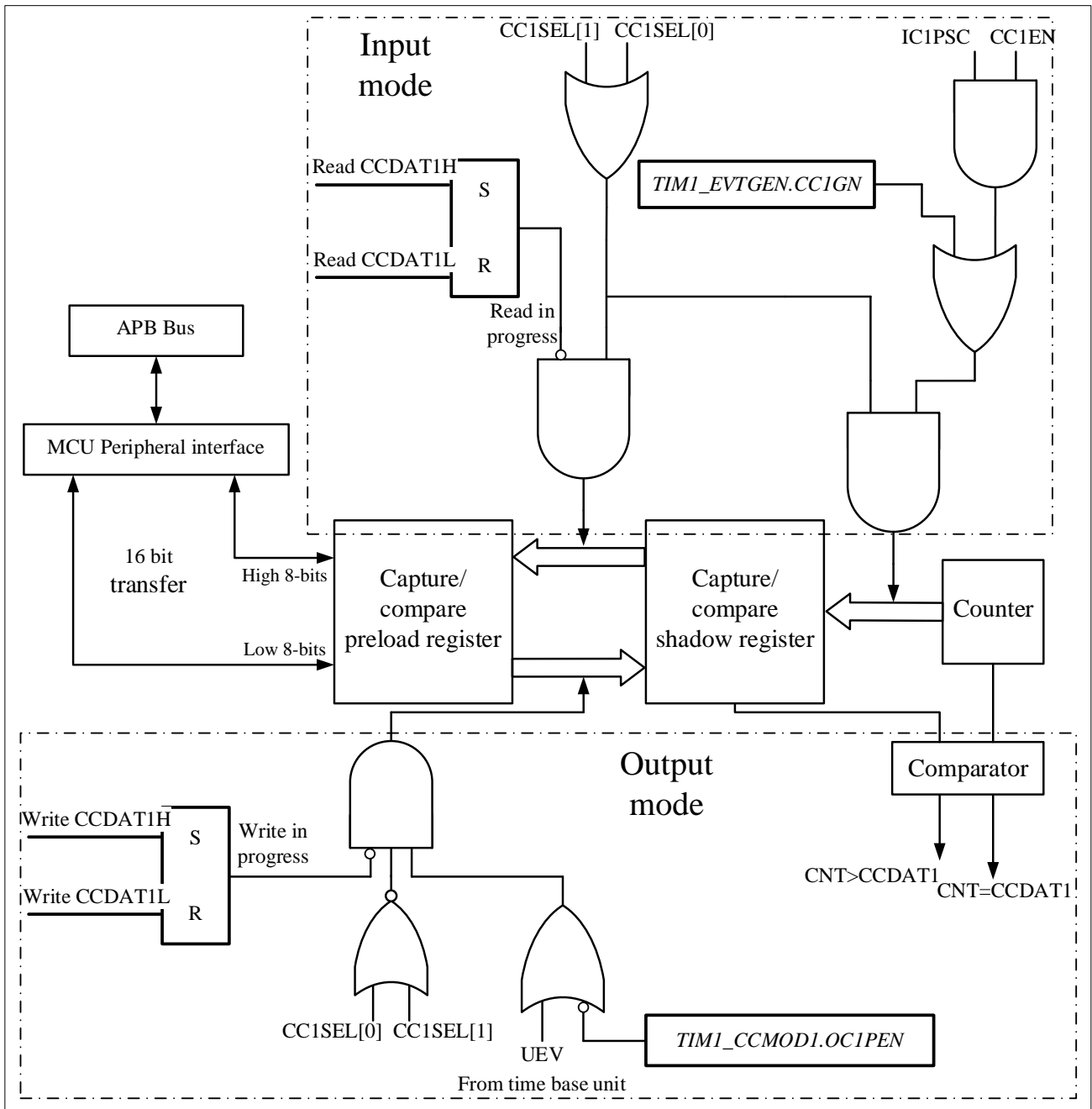
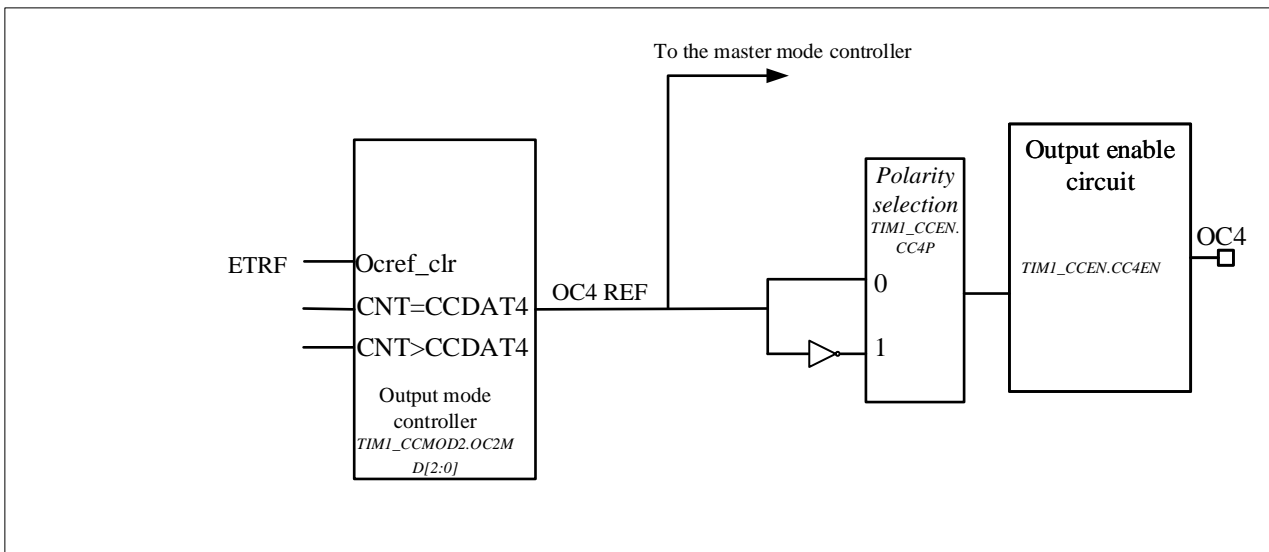

Figure 12-15 Output part of channelx (x = 1,2,3,4;take channel 4 as an example)



Reads and writes always access preloaded registers when capturing/comparing. The two specific working processes are as follows:

In capture mode, the capture is actually done in the shadow register, and then the value in the shadow register is copied into the preload register.

In compare mode, as opposed to capture mode, the value of the preload register is copied into the shadow register, which is compared with the counter.

### 12.3.5 Input capture mode

In capture mode, the TIMx\_CC DATx registers are used to latch the counter value after the ICx signal detects.

There is a capture interrupt flag TIMx\_STS.CCxITF, which can issue an interrupt or DMA request if the corresponding interrupt enable is pulled high.

The TIMx\_STS.CCxITF bit is set by hardware when a capture event occurs and is cleared by software or by reading the TIMx\_CC DATx register.

The overcapture flag TIMx\_STS.CCxOCF is set equal to 1 when the counter value is captured in the TIMx\_CC DATx register and TIMx\_STS.CCxITF is already pulled high. Unlike the former, TIMx\_STS.CCxOCF is cleared by writing 0 to it.

To achieve a rising edge of the TI1 input to capture the counter value into the TIMx\_CC DAT1 register, the configuration flow is as follows:

- To select a valid input:
 

Configure TIMx\_CCMOD1.CC1SEL to '01'. At this time, the input is the CC1 channel, and IC1 is mapped to TI1.
- Program the desired input filter duration:
 

Define the sampling frequency of the TI1 input and the length of the digital filter by configuring the TIMx\_CCMODx.ICxF bits. Example: If the input signal jitters up to 5 internal clock cycles, we must choose a

filter duration longer than these 5 clock cycles. When 8 consecutive samples (sampled at  $f_{DTS}$  frequency) with the new level are detected, we can validate the transition on TI1. Then configure TIMx\_CCMOD1.IC1F to '0011'.

- By configuring TIMx\_CCEN.CC1P=0, select the rising edge as the valid transition polarity on the TI1 channel.
- Configure the input prescaler. In this example, configure TIMx\_CCMOD1.IC1PSC= '00' to disable the prescaler because we want to capture every valid transition.
- Enable capture by configuring TIMx\_CCEN.CC1EN = '1'.

If you want to enable DMA request, you can configure TIMx\_DINTEN.CC1DEN=1. If you want to enable related interrupt request, you can configure TIMx\_DINTEN.CC1IEN bit=1

### 12.3.6 PWM input mode

There are some differences between PWM input mode and normal input capture mode, including:

- Two ICx signals are mapped to the same TIx input.
- The two ICx signals are active on edges of opposite polarity.
- Select one of two TIxFP signals as trigger input.
- The slave mode controller is configured in reset mode.

For example, the following configuration flow can be used to know the period and duty cycle of the PWM signal on TI1 (It depends on the frequency of CK\_INT and the value of the prescaler).

- Configure TIMx\_CCMOD1.CC1SEL equal to '01' to select TI1 as valid input for TIMx\_CCDAT1.
- Configure TIMx\_CCEN.CC1P equal to '0' to select the active polarity of filtered timer input 1 (TI1FP1), valid on the rising edge.
- Configure TIMx\_CCMOD1.CC2SEL equal to '10' select TI1 as valid input for TIMx\_CCDAT2.
- Configure TIMx\_CCEN.CC2P equal to 1 to select the valid polarity of filtered timer input 2 (TI1FP2), valid on the falling edge.
- Configure TIMx\_SMCTRL.TSEL=101 to select Filtered timer input 1 (TI1FP1) as valid trigger input.
- Configure TIMx\_SMCTRL.SMSEL=100 to configure the slave mode controller to reset mode.
- Configure TIMx\_CCEN.CC1EN=1 and TIMx\_CCEN.CC2EN=1 to enable capture.

Figure 12-16 PWM input mode timing

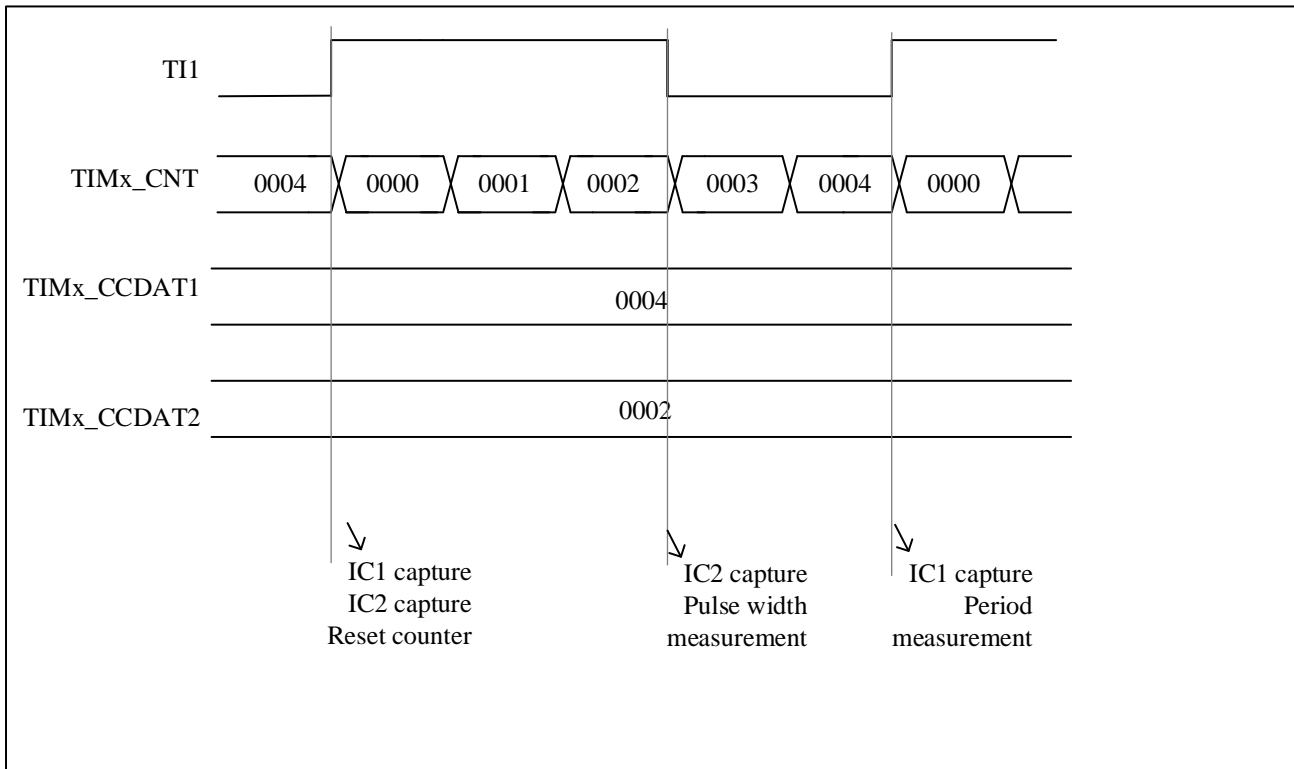

Because of only filter timer input 1 (TI1FP1) and filter timer input 2 (TI2FP2) are connected to the slave mode controller, the PWM input mode can only be used with the TIMx\_CH1/TIMx\_CH2 signals.

### 12.3.7 Forced output mode

Software can force output compare signals to active or inactive level directly, in output mode (TIMx\_CCMODx.CCxSEL=00).

User can set TIMx\_CCMODx.OCxMD=101 to force the output compare signal to active level. And the OCxREF will be forced high, OCx get opposite value to CCxP polarity bit. On the other hand, user can set TIMx\_CCMODx.OCxMD=100 to force the output compare signal to inactive level.

The values of the TIMx\_CCDATx shadow register and the counter still comparing with each other in this mode. And the flag still can be set. Therefore, the interrupt and DMA requests still can be sent.

The comparison between the output compare register TIMx\_CCDATx and the counter TIMx\_CNT has no effect on OCxREF. And the flag still can be set. Therefore, the interrupt and DMA requests still can be sent.

### 12.3.8 Output compare mode

User can use this mode to control the output waveform, or to indicate that a period of time has elapsed.

When the capture/compare register and the counter have the same value, the output compare function's operations are as follow:

- TIMx\_CCMODx.OCxMD is for output compare mode, and TIMx\_CCEN.CCxP is for output polarity. When the compare matches, if set TIMx\_CCMODx.OCxMD=000, the output pin will keep its level; if set

TIMx\_CCMODx.OCxMD=001, the output pin will be set active;if set TIMx\_CCMODx.OCxMD=010, the output pin will be set inactive;if set TIMx\_CCMODx.OCxMD=011, the output pin will be set to toggle.

- Set TIMx\_STS.CCxITF.
- If user set TIMx\_DINTEN.CCxIEN, a corresponding interrupt will be generated.
- If user set TIMx\_DINTEN.CCxDEN and set TIMx\_CTRL2.CCDSEL to select DMA request, and DMA request will be sent.

User can set TIMx\_CCMODx.OCxPEN to choose capture/compare shadow register using capture/compare preload registers(TIMx\_CCxDTx) or not.

The time resolution is one count of the counter.

In one pulse mode, the output compare mode can also be used to output a single pulse.

Here are the configuration steps for output compare mode:

- First of all, user should select the counter clock.
- Secondly, set TIMx\_AR and TIMx\_CCxDTx with desired data.
- If user need to generate an interrupt, set TIMx\_DINTEN.CCxIEN.
- Then select the output mode by set TIMx\_CCEN.CCxP, TIMx\_CCMODx.OCxMD, TIMx\_CCEN.CCxEN, etc.
- At last, set TIMx\_CTRL1.CNTEN to enable the counter.

User can update the output waveform by setting TIMx\_CCxDTx at any time, as long as the preload register is not enabled. Otherwise the TIMx\_CCxDTx shadow register will be updated at the next update event.

Here is an example.

Figure 12-17 Output compare mode, toggle on OC1

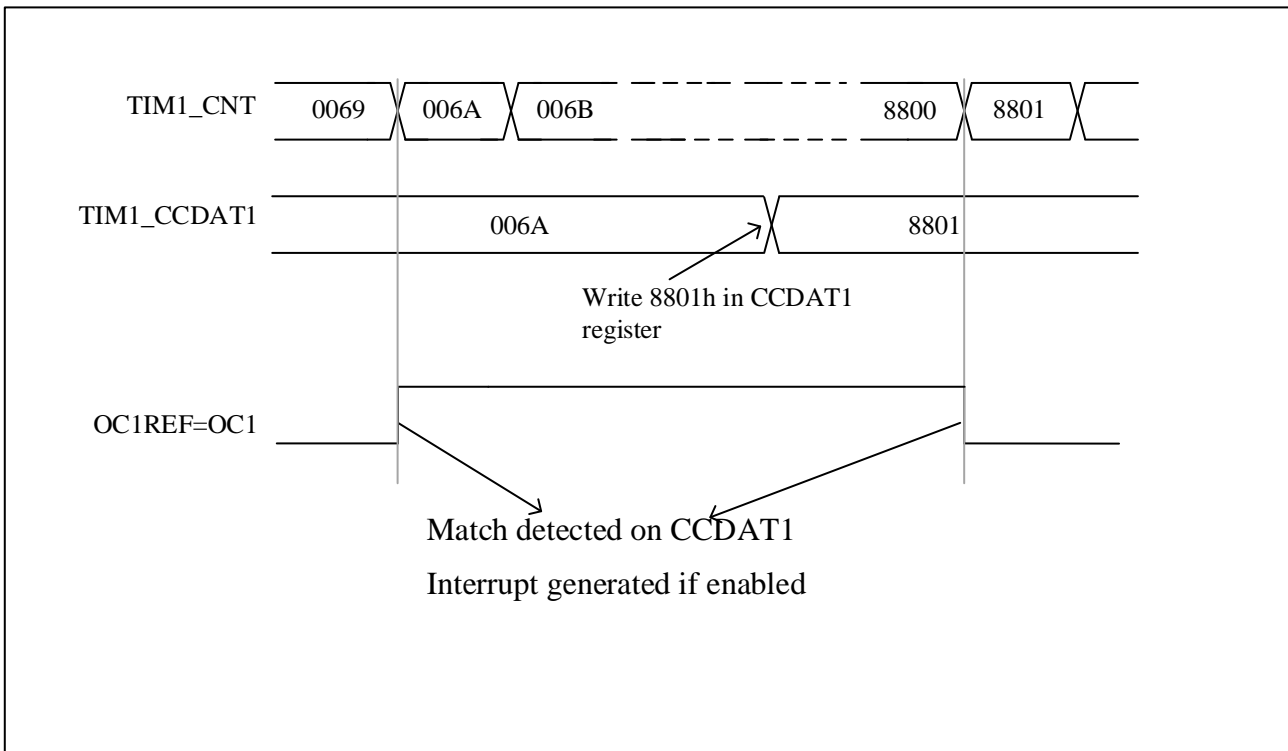

### 12.3.9 PWM mode

User can use PWM mode to generate a signal whose duty cycle is determined by the value of the TIMx\_CC DATx register and whose frequency is determined by the value of the TIMx\_AR register. And depends on the value of TIMx\_CTRL1.CAMSEL, the TIM can generate PWM signal in edge-aligned mode or center-aligned mode.

User can set PWM mode 1 or PWM mode 2 by setting TIMx\_CCMODx. OCxMD=110 or setting TIMx\_CCMODx. OCxMD=111. To enable preload register, user must set corresponding TIMx\_CCMODx.OCxPEN. And then set TIMx\_CTRL1.ARPEN to auto-reload preload register eventually.

User can set polarity of OCx by setting TIMx\_CCEN.CCxP. To enable the output of OCx, user need to set the combination of the value of CCxEN.

The values of TIMx\_CNT and TIMx\_CC DATx are always compared with each other when the TIM is under PWM mode.

Only if an update event occurs, the preload register will transfer to the shadow register. Therefore user must reset all the registers by setting TIMx\_EVTGEN.UDGN before the counter starts counting.

#### 12.3.9.1 PWM center-aligned mode

If user set TIMx\_CTRL1.CAMSEL equal 01, 10 or 11, the PWM center-aligned mode will be active. The setting of the compare flag depends on the value of TIMx\_CTRL1.CAMSEL. There are three kinds of situation that the compare flag is set, only when the counter counts up, only when the counter counts down, or when the counter counts up and counts down. User should not modified TIMx\_CTRL1.DIR by software, it is updated by hardware.

Examples of center-aligned PWM waveforms is as follow, and the setting of the waveform are: TIMx\_AR=8, PWM mode 1, the compare flag is set when the counter counts down corresponding to TIMx\_CTRL1. CAMSEL=01.

Figure 12-18 Center-aligned PWM waveform (AR=8)

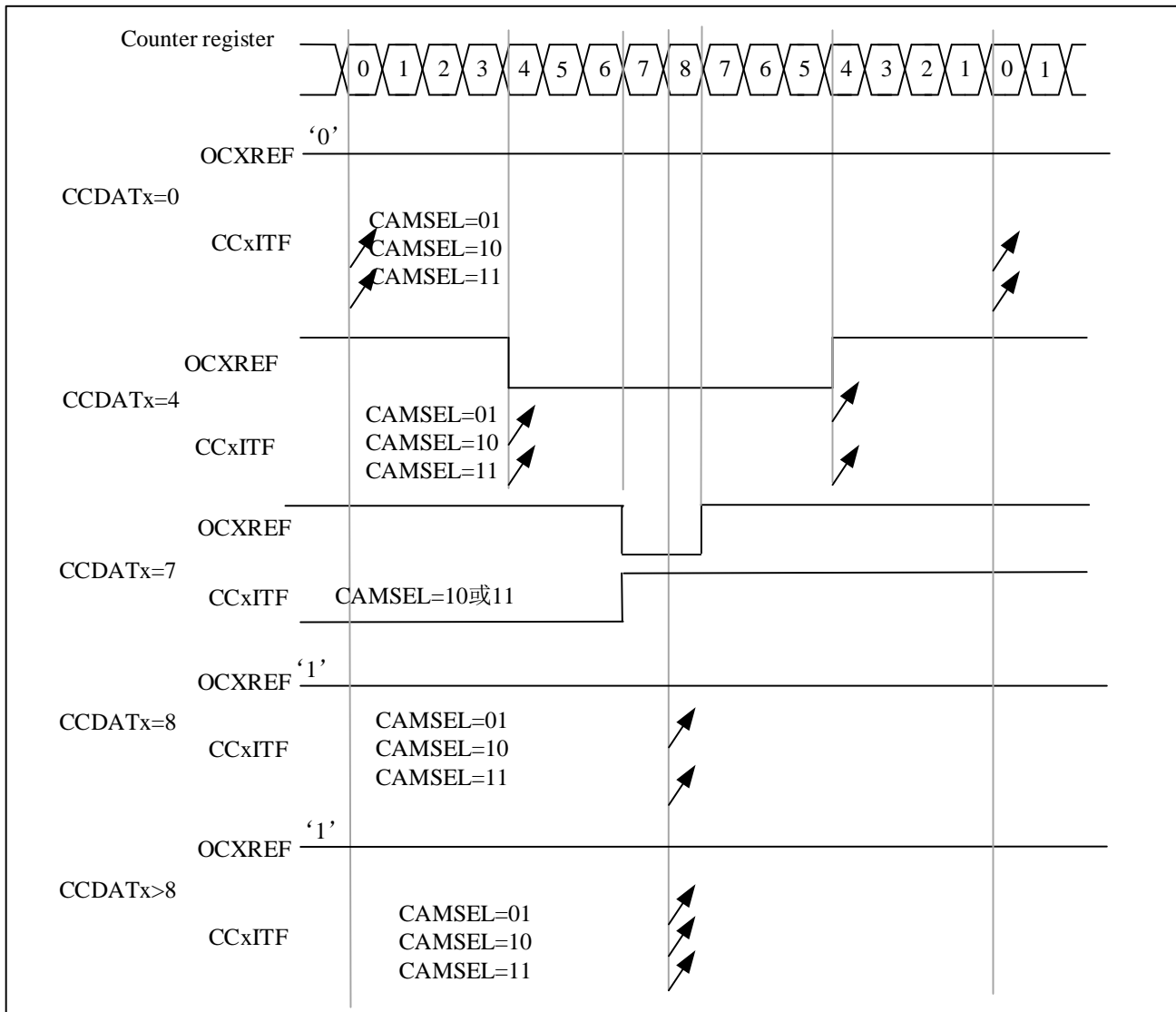

Notes that user should know when using center-aligned mode are as follow:

- It depends on the value of TIMx\_CTRL1.DIR that the counter counts up or down. Caution that the DIR and CAMSEL bits should not be changed at the same time.
- User should not write the counter while running in center-aligned mode, otherwise it will cause unexpected results. Here are some example:
  - ◆ If the value written into the counter is 0 or is the value of TIMx\_AR, the direction will be updated but the update event will not be generated.
  - ◆ If the value written into the counter is greater than the value of auto-reload, the direction will not be updated.
- To be on the safe side, user is suggested setting TIMx\_EVTGEN.UDGN to generate an update by software before starting the counter, and not writing the counter while it is running.

### 12.3.9.2 PWM edge-aligned mode

There are two kinds of configuration in edge-aligned mode, up-counting and down-counting.

● **Up-counting**

User can set `TIMx_CTRL1.DIR=0` to make counter counts up.

Here is an example for PWM mode1.

When `TIMx_CNT < TIMx_CCxDATx`, the reference PWM signal `OCxREF` is high. Otherwise it will be low. If the compare value in `TIMx_CCxDATx` is greater than the auto-reload value, the `OCxREF` will remains 1. Conversely, if the compare value is 0, the `OCxREF` will remains 0.

When `TIMx_AR=8`, the PWM waveforms are as follow.

Figure 12-19 Edge-aligned PWM waveform (APR=8)

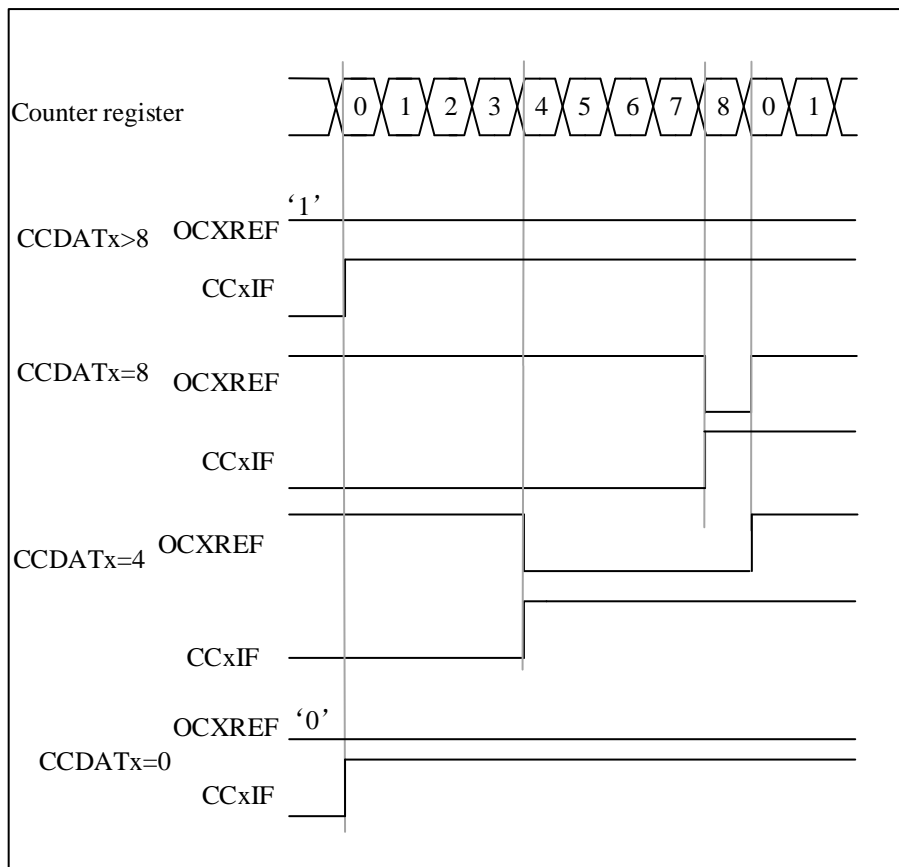

● **Down-counting**

User can set `TIMx_CTRL1.DIR=1` to make counter counts down.

Here is an example for PWM mode1.

When `TIMx_CNT > TIMx_CCxDATx`, the reference PWM signal `OCxREF` is low. Otherwise it will be high. If the compare value in `TIMx_CCxDATx` is greater than the auto-reload value, the `OCxREF` will remains 1.

*Note: If the  $n$ th PWM cycle `CCxDATx` shadow register  $\geq$  `AR` value, the shadow register value of `CCxDATx` in the  $(n+1)$ th PWM cycle is 0. At the moment when the counter is 0 in the  $(n+1)$ th PWM cycle, although the value of the counter = `CCxDATx` shadow register = 0 and `OCxREF` = '0', no compare event will be generated.*

### 12.3.10 One-pulse mode

In the one-pulse mode (ONEPM), a trigger signal is received, and a pulse  $t_{PULSE}$  with a controllable pulse width is generated after a controllable delay  $t_{DELAY}$ . The output mode needs to be configured as output compare mode or PWM mode. After selecting one-pulse mode, the counter will stop counting after the update event UEV is generated.

Figure 12-20 Example of One-pulse mode

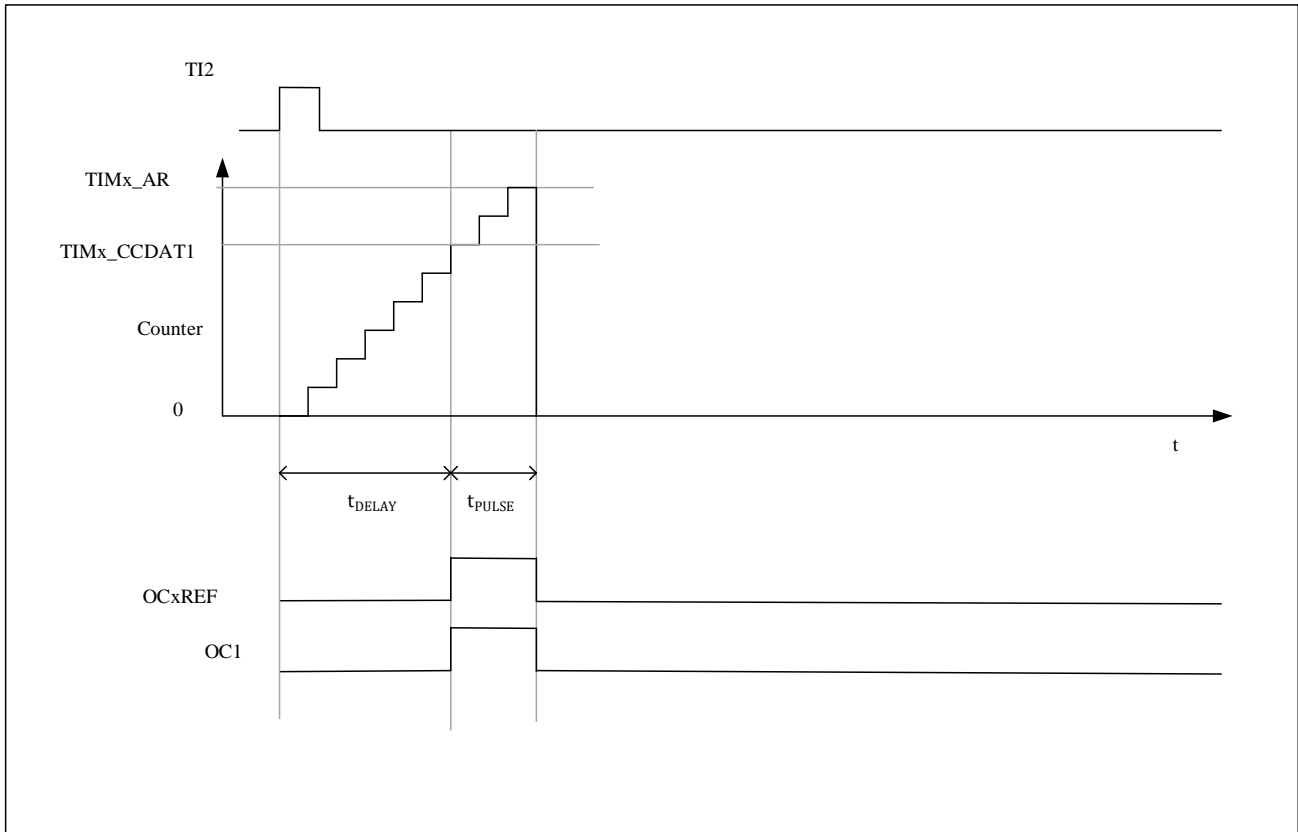

The following is an example of a one-pulse mode:

A rising edge trigger is detected from the TI2 input, and a pulse with a width of  $t_{PULSE}$  is generated on OC1 after a delay of  $t_{DELAY}$ .

1. Counter configuration: count up, counter  $TIMx\_CNT < TIMx\_CCDAT1 \leq TIMx\_AR$ ;
2. TI2FP2 is mapped to TI2,  $TIMx\_CCMOD1.CC2SEL = '01'$ ; TI2FP2 is configured for rising edge detection,  $TIMx\_CCEN.CC2P = '0'$ ;
3. TI2FP2 acts as the trigger (TRGI) of the slave mode controller and starts the counter,  $TIMx\_SMCTRL.TSEL = '110'$ ,  $TIMx\_SMCTRL.SMSEL = '110'$  (trigger mode);
4.  $TIMx\_CCDAT1$  writes the count value to be delayed ( $t_{DELAY}$ ),  $TIMx\_AR - TIMx\_CCDAT1$  is the count value of the pulse width  $t_{PULSE}$ ;
5. Configure  $TIMx\_CTRL1.ONEPM = 1$  to enable single pulse mode, configure  $TIMx\_CCMOD1.OC1MD = '111'$  to select PWM2 mode;
6. Wait for an external trigger event on TI2, and a one pulse waveform will be output on OC1;

### 12.3.10.1 Special case: OCx fast enable:

In one-pulse mode, an edge is detected through the TIX input, and triggers the start of the counter to count to the comparison value and then output a pulse. These operations limit the minimum delay  $t_{DELAY}$  that can be achieved.

You can set `TIMx_CCMODx.OCxFEN=1` to turn on OCx fast enable, after triggering the rising edge, the OCxREF signal will be forced to be converted to the same level as the comparison match occurs immediately, regardless of the comparison result. OCxFEN fast enable only takes effect when the channel mode is configured for PWM1 and PWM2 modes.

### 12.3.11 Clearing the OCxREF signal on an external event

If user set `TIMx_CCMODx.OCxCEN=1`, high level of ETRF input can be used to driven the OCxREF signal to low, and the OCxREF signal will remains low, until the next UEV happens. Only output compare and PWM modes can use this function. This cannot be used when it is in forced mode.

Here is an example for it. To control the current, user can connect the ETR signal to the output of a comparator, and the operation for ETR should be as follow:

- Set `TIMx_SMCTRL.EXTPS=00` to disable the external trigger prescaler.
- Set `TIMx_SMCTRL.EXCCEN=0` to disable the external clock mode 2.
- Set `TIMx_SMCTRL.EXTP` and `TIMx_SMCTRL.EXTF` to configure the external trigger polarity and external trigger filter according to the need.

Here is an example for the case that when ETRF input becomes high, the behavior of OCxREF signal for different value of OCxCEN. Timer is set to be in PWM mode in this case.

Figure 12-21 Control circuit in reset mode

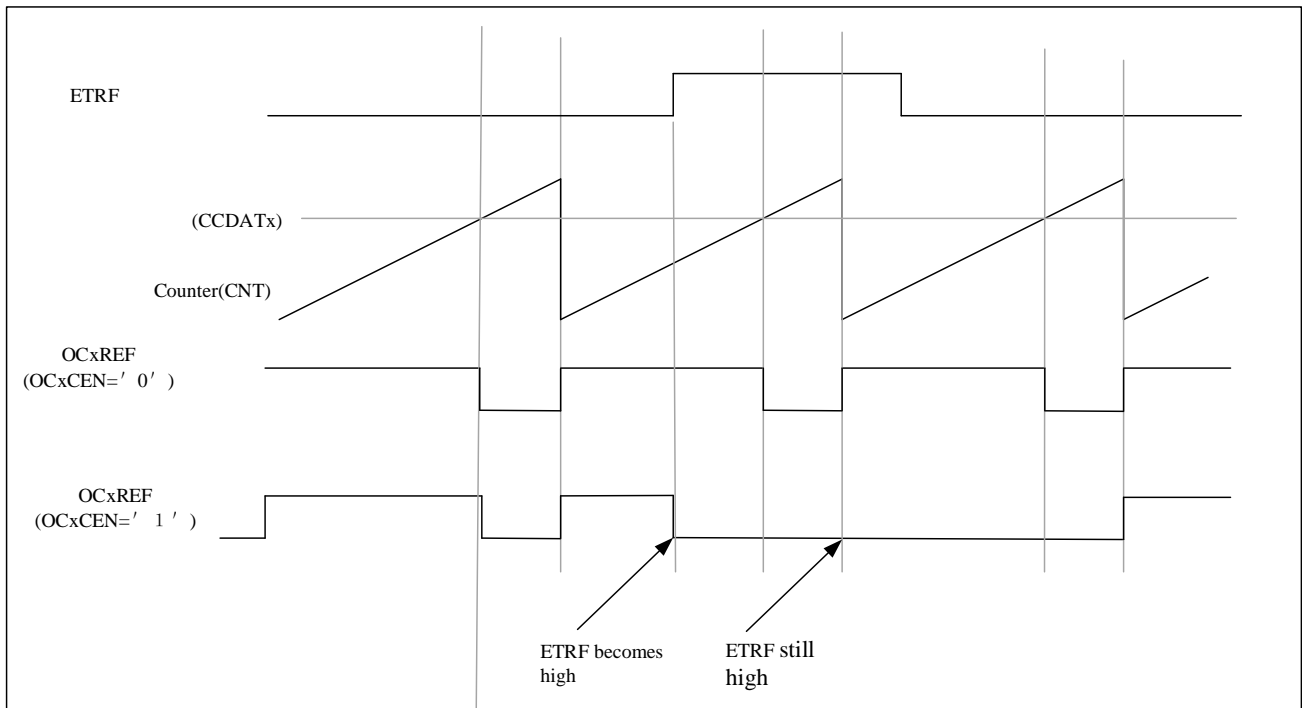

### 12.3.12 Debug mode

When the microcontroller is in debug mode (the Cortex-M4 core halted), depending on the `DBG_CTRL.TIMx_STOP` configuration in the DBG module, the TIMx counter can either continue to work normally or stop. For more details, see 29.4.3.

### 12.3.13 TIMx and external trigger synchronization

Same as advanced timer. See 11.3.16.

### 12.3.14 Timer synchronization

All TIMx timers are internally connected to each other. This implementation allows any master timer to provide trigger to reset, start, stop or provide a clock for the other slave timers. The master clock is used for internal counter and can be prescaled. Below figure shows a Block diagram of timer interconnection.

The synchronization function does not support dynamic change of the connection. User should configure and enable the slave timer before enable the master timer's trigger or clock.

Figure 12-22 Block diagram of timer interconnection

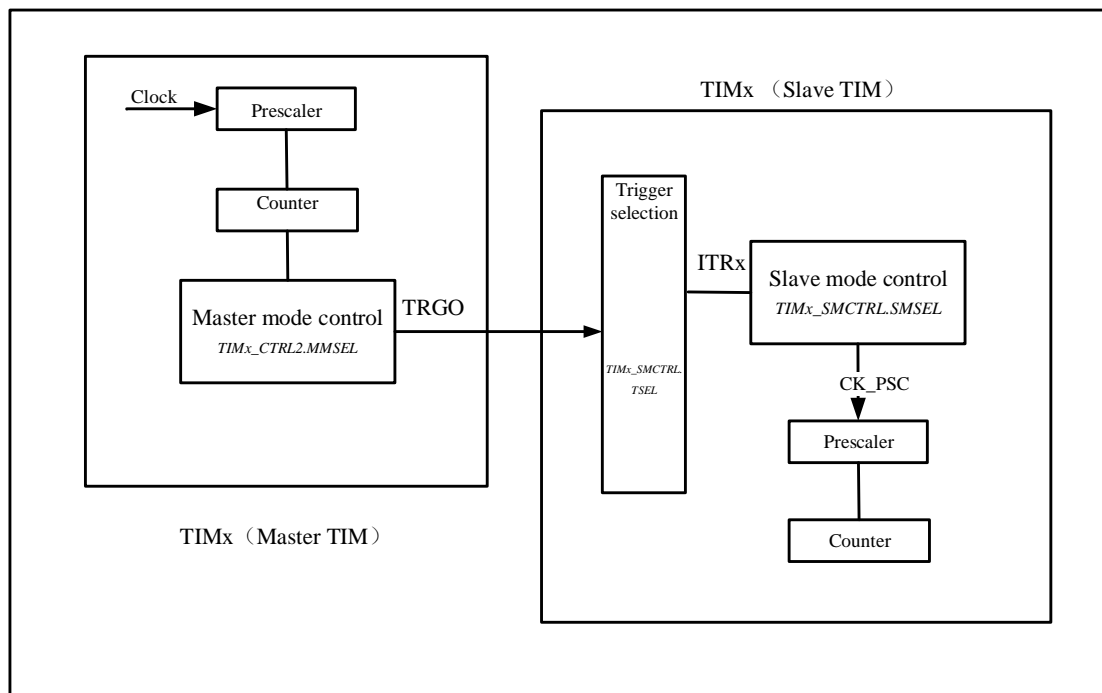

#### 12.3.14.1 Master timer as a prescaler for another timer

TIM1 as a prescaler for TIM2. TIM1 is maser, TIM2 is slave.

User need to do the following steps for this configuration.

- Setting `TIM1_CTRL2.MMSEL='010'` to use the update event of TIM1 as trigger output.
- Configure `TIM2_SMCTRL.TSEL='000'`, connect the TRGO of TIM1 to TIM2.

- Configure TIM2\_SMCTRL.SMSEL = '111', the slave mode controller will be configured in external clock mode 1.
- Start TIM2 by setting TIM2\_CTRL1.CNTEN = '1'.
- Start TIM1 by setting TIM1\_CTRL1.CNTEN = '1'.

*Note: If user select OCx as the trigger output of TIM1 by configuring MMSEL = '1xx', OCx rising edge will be used to drive timer2.*

### 12.3.14.2 Master timer to enable another timer

In this example, TIM2 is enabled by the output compare of TIM1. TIM2 counter will start to count after the OC1REF output from TIM1 is high. Both counters are clocked based on CK\_INT via a prescaler divide by 3 is performed ( $f_{CK\_CNT} = f_{CK\_INT}/3$ ).

The configuration steps are shown as below.

- Setting TIM1\_CTRL2.MMSEL='100' to use the OC1REF of TIM1 as trigger output.
- Configure TIM1\_CCMOD1 register to configure the OC1REF output waveform.
- Setting TIM2\_SMCTRL.TSEL = '000' to connect TIM1 trigger output to TIM2.
- Setting TIM2\_SMCTRL.SMSEL = '101' to set TIM2 to gated mode.
- Setting TIM2\_CTRL1.CNTEN = '1' to start TIM2.
- Setting TIM1\_CTRL1.CNTEN = '1' to start TIM1.

*Note: The TIM2 clock is not synchronized with the TIM1 clock, this mode only affects the TIM2 counter enable signal.*

Figure 12-23 TIM2 gated by OC1REF of TIM1

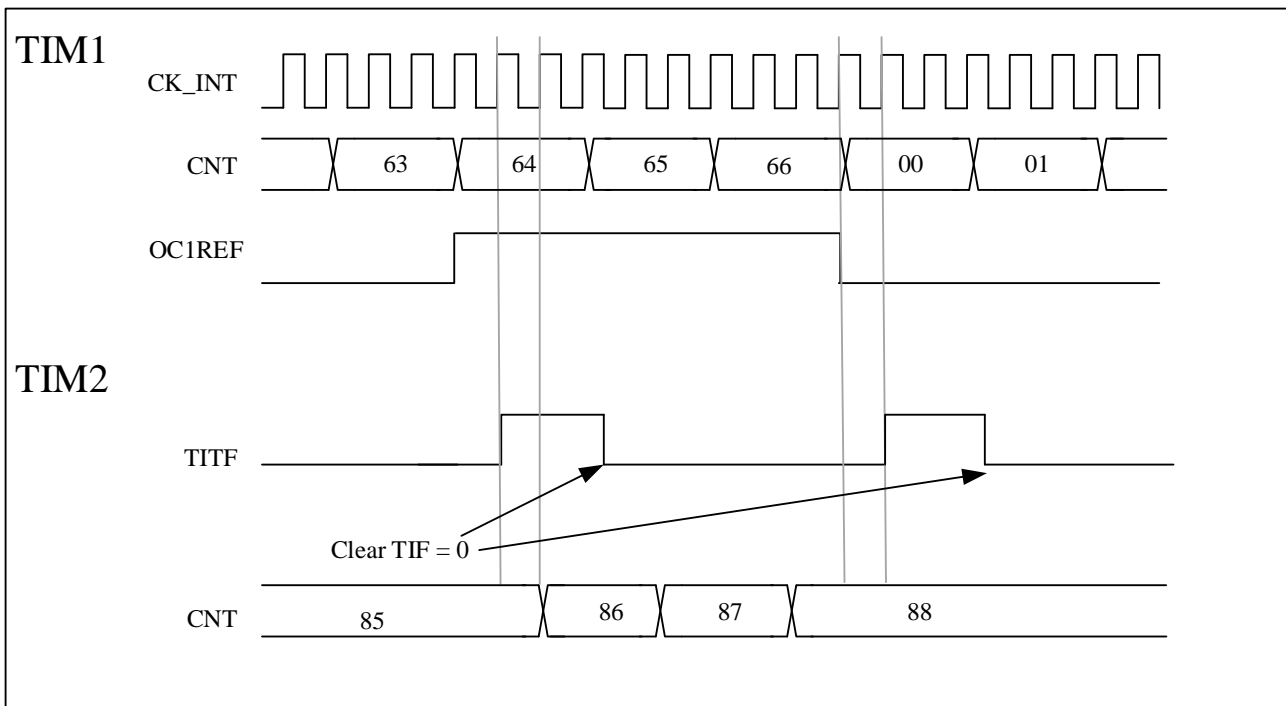

In the next example, Gated TIM2 with enable signal of TIM1, Setting TIM1\_CTRL1.CNTEN = '0' to stop TIM1. TIM2

counts on the divided internal clock only when TIM1 is enable. Both counters are clocked based on CK\_INT via a prescaler divide by 3 is performed ( $f_{CK\_CNT} = f_{CK\_INT}/3$ ).

The configuration steps are shown as below

- Setting TIM1\_CTRL2.MMSEL='001' to use the enable signal of TIM1 as trigger output
- Setting TIM2\_SMCTRL.TSEL = '000' to configure TIM2 to get the trigger input from TIM1
- Setting TIM2\_SMCTRL.SMSEL = '101' to configure TIM2 in gated mode.
- Setting TIM2\_CTRL1.CNTEN= '1' to start TIM2.
- Setting TIM1\_CTRL1.CNTEN= '1' to start TIM1.
- Setting TIM1\_CTRL1.CNTEN= '0' to stop TIM1.

Figure 12-24 TIM2 gated by enable signal of TIM1

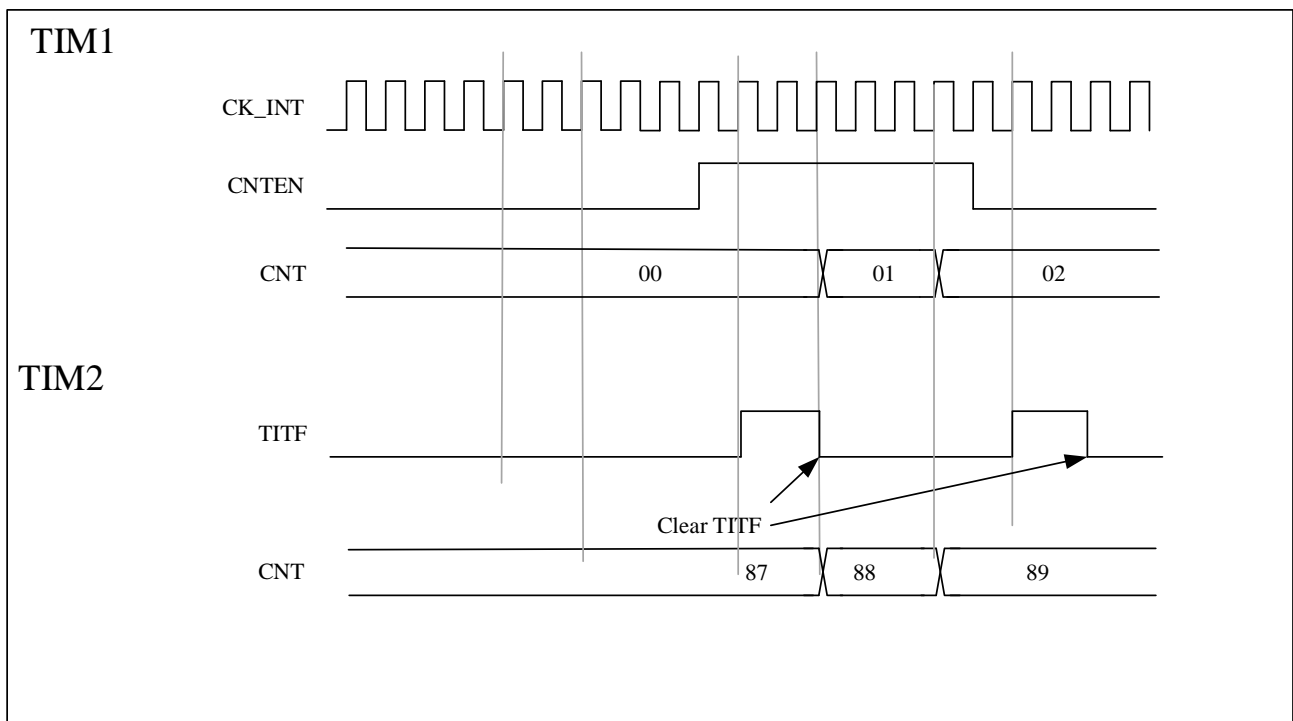

### 12.3.14.3 Master timer to start another timer

In this example, we can use update event as trigger source. TIM1 is master, TIM2 is slave.

The configuration steps are shown as below:

- Setting TIM1\_CTRL2.MMSEL='010' to use the update event of TIM1 as trigger output
- Configure TIM1\_AR register to set the output period.
- Setting TIM2\_SMCTRL.TSEL= '000' to connect TIM1 trigger output to TIM2.
- Setting TIM2\_SMCTRL.SMSEL = '110' to set TIM2 to trigger mode.
- Setting TIM1\_CTRL1.CNTEN=1 to start TIM1.

Figure 12-25 Trigger TIM2 with an update of TIM1

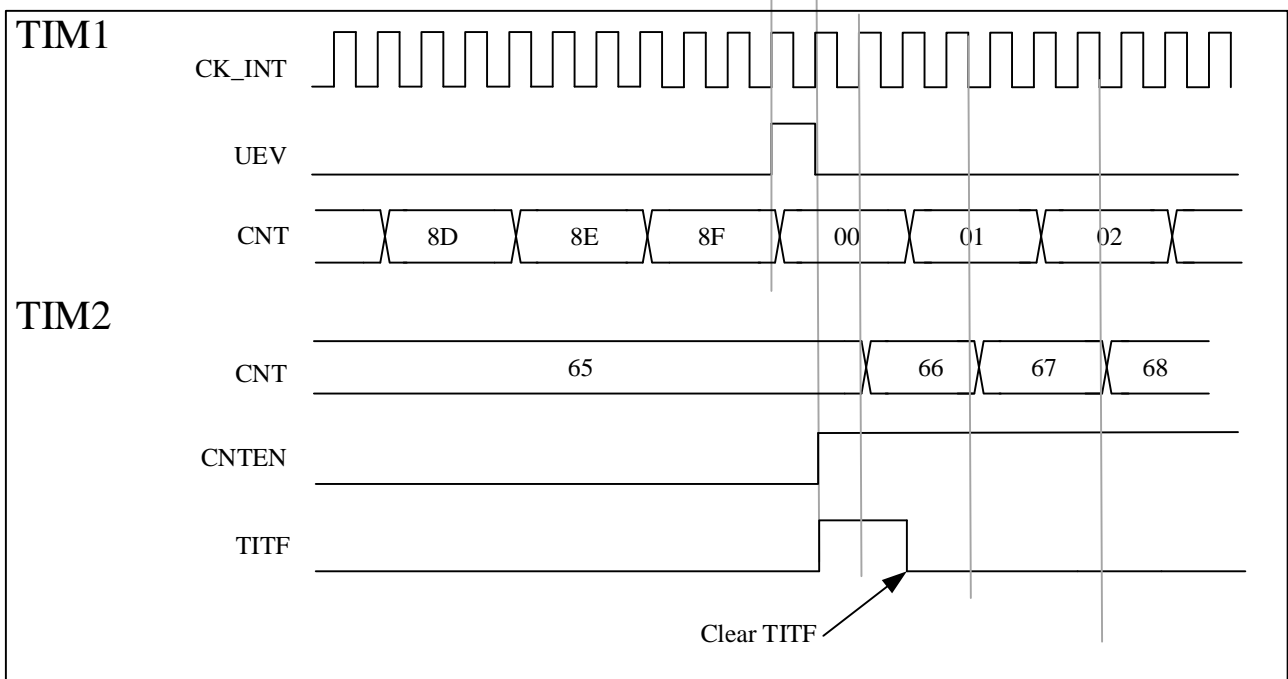

#### 12.3.14.4 Start 2 timers synchronously using an external trigger

In this example, TIM1 is enabled when TIM1's TI1 input rises, and TIM2 is enabled when TIM1 is enabled. To ensure the alignment of counters, TIM1 must be configured in master/slave mode. For TI1, TIM1 is the slave; for TIM2, TIM1 is the master.

The configuration steps are shown as below:

- Setting `TIM1.MMSEL = '001'` to use the enable signal as trigger output
- Setting `TIM1_SMCTRL.TSEL = '100'` to configure the TIM1 to slave mode and receive the trigger input of TI1.
- Setting `TIM1_SMCTRL.SMSEL = '110'` to configure TIM1 to trigger mode.
- Setting `TIM1_SMCTRL.MSMD = '1'` to configure TIM1 to master/slave mode.
- Setting `TIM2_SMCTRL.TSEL = '000'` to connect TIM1 trigger output to TIM2.
- Setting `TIM2_SMCTRL.SMSEL = '110'` to configure TIM2 to trigger mode.

When TI1 rising edge arrives, both timers start counting synchronously according to the internal clock, and both TITF flags are set simultaneously.

*The following figure shows a delay between CNTEN and CK\_PSC of TIM1 in master/slave mode.*

Figure 12-26 Triggers timers 1 and 2 using the TI1 input of TIM1

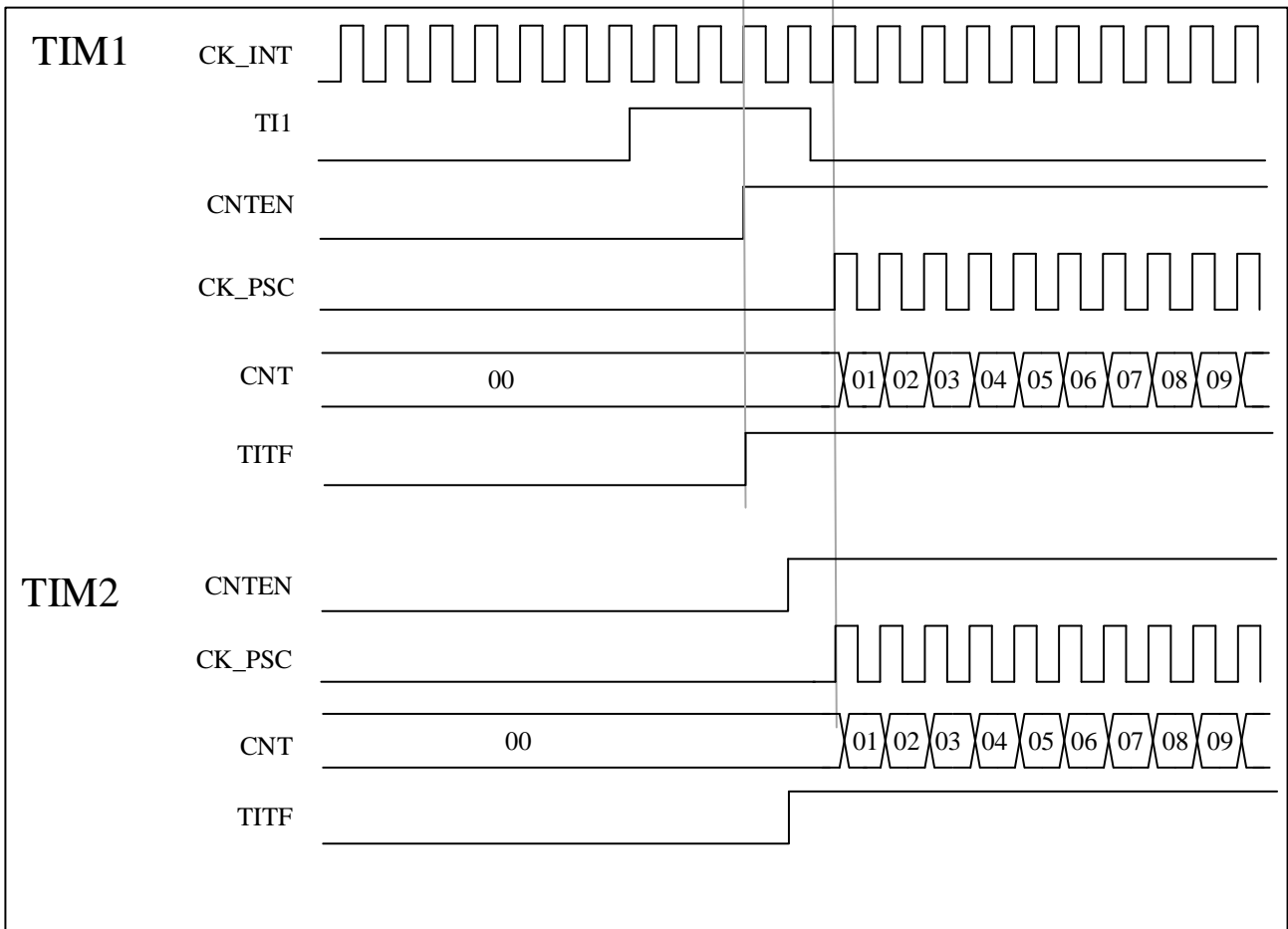

### 12.3.15 Encoder interface mode

The encoder uses two inputs TI1 and TI2 as an interface and the counter counts on every edge change on TI1FP1 or TI2FP2. The counting direction is automatically controlled by hardware TIMx\_CTRL1.DIR. There are three types of encoder counting modes:

1. The counter only counts on the edge of TI1, TIMx\_SMCTRL.SMSEL = '001';
2. The counter only counts on the edge of TI2, TIMx\_SMCTRL.SMSEL = '010';
3. The counter counts on the edges of TI1 and TI2 at the same time, TIMx\_SMCTRL.SMSEL = '011';

The encoder interface is equivalent to using an external clock with direction selection, and the counter only counts continuously between 0 and the auto-reload value (TIMx\_AR.AR [15:0]). Therefore, it is necessary to configure the auto-reload register TIMx\_AR in advance.

*Note: Encoder mode and external clock mode 2 are not compatible and must not be selected together.*

The relationship between the counting direction and the encoder signal is shown in **Table 12-1**:

Table 12-1 Counting direction versus encoder signals

|  | Level on opposite signals | TI1FP1 signal | TI2FP2 signal |
|--|---------------------------|---------------|---------------|
|--|---------------------------|---------------|---------------|

| Active edge                | (TI1FP1 for TI2,<br>TI2FP2 for TI1) | Rising        | Falling       | Rising        | Falling       |
|----------------------------|-------------------------------------|---------------|---------------|---------------|---------------|
| Counting only at TI1       | High                                | Counting down | Counting up   | Don't count   | Don't count   |
|                            | Low                                 | Counting up   | Counting down | Don't count   | Don't count   |
| Counting only at TI2       | High                                | Don't count   | Don't count   | Counting up   | Counting down |
|                            | Low                                 | Don't count   | Don't count   | Counting down | Counting up   |
| Counting on<br>TI1 and TI2 | High                                | Counting down | Counting up   | Counting up   | Counting down |
|                            | Low                                 | Counting up   | Counting down | Counting down | Counting up   |

Here is an example of an encoder with dual edge triggering selected to suppress input jitter:

1. IC1FP1 is mapped to TI1 (TIMx\_CCMOD1.CC1SEL= '01'), IC1FP1 is not inverted (TIMx\_CCEN.CC1P= '0');
2. IC1FP2 is mapped to TI2 (TIMx\_CCMOD2.CC2SEL= '01'), IC2FP2 is not inverted (TIMx\_CCEN.CC2P= '0');
3. The input is valid on both rising and falling edges (TIMx\_SMCTRL.SMSEL = '011');
4. Enable counter TIMx\_CTRL1.CNTEN= '1';

Figure 12-27 Example of counter operation in encoder interface mode

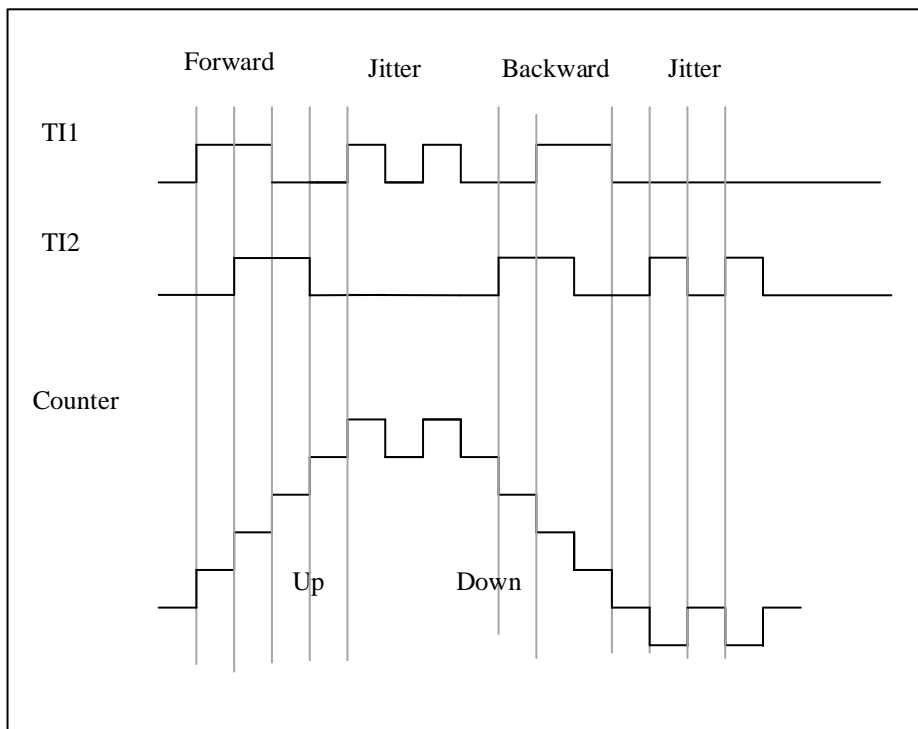

The following figure shows the example of counter behavior when IC1FP1 polarity is inverted (CC1P= '1', other configurations are the same as above)

Figure 12-28 Encoder interface mode example with IC1FP1 polarity inverted

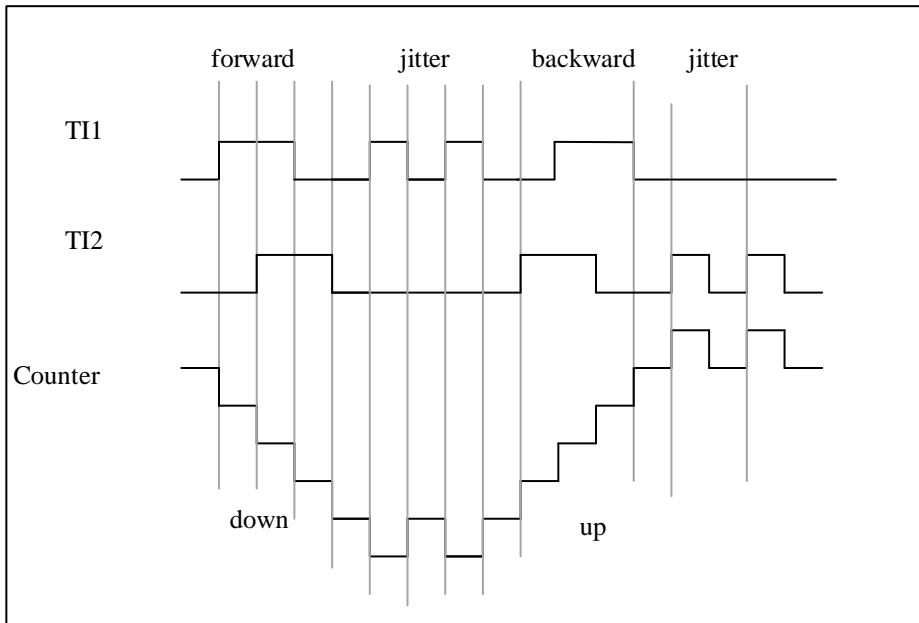

### 12.3.16 Interfacing with Hall sensor

Please refer to 11.3.20

## 12.4 TIMx register description(x=2, 3,4 and 5)

For abbreviations used in registers, see section 1.1.

These peripheral registers can be operated as half word (16-bits) or one word (32-bits).

### 12.4.1 Register Overview

Table 12-2 Register map and reset value

| Offset | Register    | 31       | 30 | 29 | 28 | 27 | 26 | 25 | 24 | 23 | 22 | 21 | 20 | 19 | 18 | 17 | 16 | 15     | 14       | 13         | 12         | 11        | 10       | 9         | 8         | 7    | 6           | 5      | 4            | 3      | 2      | 1     | 0     |   |   |   |   |   |   |   |   |   |   |   |   |
|--------|-------------|----------|----|----|----|----|----|----|----|----|----|----|----|----|----|----|----|--------|----------|------------|------------|-----------|----------|-----------|-----------|------|-------------|--------|--------------|--------|--------|-------|-------|---|---|---|---|---|---|---|---|---|---|---|---|
| 000h   | TIMx_CTRL1  | Reserved |    |    |    |    |    |    |    |    |    |    |    |    |    |    |    | CLRSEL | C4SEL    | C3SEL      | C2SEL      | C1SEL     | Reserved | CLKD[1:0] |           | ARPE | CAMSEL[1:0] |        | DIR          | ONEP   | UPRS   | UPDIS | CNTEN |   |   |   |   |   |   |   |   |   |   |   |   |
|        | Reset Value | 0        |    |    |    |    |    |    |    |    |    |    |    |    |    |    |    | 0      | 0        | 0          | 0          | 0         | 0        | 0         | 0         | 0    | 0           | 0      | 0            | 0      | 0      | 0     | 0     | 0 | 0 | 0 | 0 | 0 | 0 | 0 | 0 | 0 | 0 | 0 | 0 |
| 004h   | TIMx_CTRL2  | Reserved |    |    |    |    |    |    |    |    |    |    |    |    |    |    |    | ETRSEL |          | TISEL      | MMSEL[2:0] |           | CCDSEL   | Reserved  |           |      |             |        |              |        |        |       |       |   |   |   |   |   |   |   |   |   |   |   |   |
|        | Reset Value | 0        |    |    |    |    |    |    |    |    |    |    |    |    |    |    |    | 0      | 0        | 0          | 0          | 0         | 0        | 0         | 0         | 0    | 0           | 0      | 0            | 0      | 0      | 0     | 0     | 0 | 0 | 0 | 0 | 0 | 0 | 0 | 0 | 0 | 0 | 0 | 0 |
| 008h   | TIMx_SMCTRL | Reserved |    |    |    |    |    |    |    |    |    |    |    |    |    |    |    | EXTP   | EXCEN    | EXTPS[1:0] |            | EXTF[3:0] |          | MSMD      | TSEL[2:0] |      | Reserved    |        | SMSELEL[2:0] |        |        |       |       |   |   |   |   |   |   |   |   |   |   |   |   |
|        | Reset Value | 0        |    |    |    |    |    |    |    |    |    |    |    |    |    |    |    | 0      | 0        | 0          | 0          | 0         | 0        | 0         | 0         | 0    | 0           | 0      | 0            | 0      | 0      | 0     | 0     | 0 | 0 | 0 | 0 | 0 | 0 | 0 | 0 | 0 | 0 | 0 | 0 |
| 00Ch   | TIMx_DINTEN | Reserved |    |    |    |    |    |    |    |    |    |    |    |    |    |    |    | TDEN   | Reserved | CC4DEN     | CC3DEN     | CC2DEN    | CC1DEN   | UDEN      | Reserved  | T1EN | Reserved    | CC4IEN | CC3IEN       | CC2IEN | CC1IEN | UIEN  |       |   |   |   |   |   |   |   |   |   |   |   |   |
|        |             |          |    |    |    |    |    |    |    |    |    |    |    |    |    |    |    |        |          |            |            |           |          |           |           |      |             |        |              |        |        |       |       |   |   |   |   |   |   |   |   |   |   |   |   |

| Offset | Register    | 31       | 30 | 29 | 28 | 27 | 26 | 25 | 24 | 23 | 22 | 21 | 20 | 19 | 18 | 17 | 16           | 15         | 14       | 13          | 12          | 11          | 10          | 9      | 8          | 7           | 6           | 5      | 4           | 3      | 2     | 1    | 0 |  |
|--------|-------------|----------|----|----|----|----|----|----|----|----|----|----|----|----|----|----|--------------|------------|----------|-------------|-------------|-------------|-------------|--------|------------|-------------|-------------|--------|-------------|--------|-------|------|---|--|
|        | Reset Value |          |    |    |    |    |    |    |    |    |    |    |    |    |    |    |              |            | 0        |             |             | 0           | 0           | 0      | 0          |             | 0           |        | 0           | 0      | 0     | 0    |   |  |
| 010h   | TIMx_STS    | Reserved |    |    |    |    |    |    |    |    |    |    |    |    |    |    | CC4OCF       | CC3OCF     | CC2OCF   | CC1OCF      | Reserved    |             |             | TITF   | Reserved   |             | CC4ITF      | CC3ITF | CC2ITF      | CC1ITF | UDITF |      |   |  |
|        | Reset Value |          |    |    |    |    |    |    |    |    |    |    |    |    |    |    |              |            | 0        | 0           | 0           | 0           |             |        |            | 0           | 0           | 0      | 0           | 0      | 0     | 0    |   |  |
| 014h   | TIMx_EVTGEN | Reserved |    |    |    |    |    |    |    |    |    |    |    |    |    |    |              |            |          |             |             |             |             |        | TGN        | Reserved    |             | CC4GN  | CC3GN       | CC2GN  | CC1GN | UDGN |   |  |
|        | Reset Value |          |    |    |    |    |    |    |    |    |    |    |    |    |    |    |              |            |          |             |             |             |             |        |            | 0           | 0           | 0      | 0           | 0      | 0     | 0    |   |  |
| 018h   | TIMx_CCMOD1 | Reserved |    |    |    |    |    |    |    |    |    |    |    |    |    |    | OC2CEN       | OC2MD[2:0] |          | OC2PEN      | OC2FEN      | CC2SEL[1:0] |             | OC1CEN | OC1MD[2:0] |             | OC1PEN      | OC1FEN | CC1SEL[1:0] |        |       |      |   |  |
|        | Reset Value |          |    |    |    |    |    |    |    |    |    |    |    |    |    |    |              |            | 0        | 0           | 0           | 0           | 0           | 0      | 0          | 0           | 0           | 0      | 0           | 0      | 0     |      |   |  |
| 018h   | TIMx_CCMOD1 | Reserved |    |    |    |    |    |    |    |    |    |    |    |    |    |    | IC2F[3:0]    |            |          | IC2PSC[1:0] | CC2SEL[1:0] |             | IC1F[3:0]   |        |            | IC1PSC[1:0] | CC1SEL[1:0] |        |             |        |       |      |   |  |
|        | Reset Value |          |    |    |    |    |    |    |    |    |    |    |    |    |    |    |              |            | 0        | 0           | 0           | 0           | 0           | 0      | 0          | 0           | 0           | 0      | 0           | 0      | 0     |      |   |  |
| 01Ch   | TIMx_CCMOD2 | Reserved |    |    |    |    |    |    |    |    |    |    |    |    |    |    | OC4CEN       | OC4MD[2:0] |          | OC4PEN      | OC4FEN      | CC4SEL[1:0] |             | OC3CEN | OC3MD[2:0] |             | OC3PEN      | OC3FEN | CC3SEL[1:0] |        |       |      |   |  |
|        | Reset Value |          |    |    |    |    |    |    |    |    |    |    |    |    |    |    |              |            | 0        | 0           | 0           | 0           | 0           | 0      | 0          | 0           | 0           | 0      | 0           | 0      | 0     |      |   |  |
| 01Ch   | TIMx_CCMOD2 | Reserved |    |    |    |    |    |    |    |    |    |    |    |    |    |    | IC4F[3:0]    |            |          | IC4PSC[1:0] | CC4SEL[1:0] |             | IC3F[3:0]   |        |            | IC3PSC[1:0] | CC3SEL[1:0] |        |             |        |       |      |   |  |
|        | Reset Value |          |    |    |    |    |    |    |    |    |    |    |    |    |    |    |              |            | 0        | 0           | 0           | 0           | 0           | 0      | 0          | 0           | 0           | 0      | 0           | 0      | 0     |      |   |  |
| 020h   | TIMx_CCEN   | Reserved |    |    |    |    |    |    |    |    |    |    |    |    |    |    | CC4P         | CC4EN      | Reserved |             | CC3P        | CC3EN       | Reserved    |        | CC2P       | CC2EN       | Reserved    |        | CC1P        | CC1EN  |       |      |   |  |
|        | Reset Value |          |    |    |    |    |    |    |    |    |    |    |    |    |    |    |              |            | 0        | 0           |             |             | 0           | 0      |            |             | 0           | 0      |             |        | 0     | 0    |   |  |
| 024h   | TIMx_CNT    | Reserved |    |    |    |    |    |    |    |    |    |    |    |    |    |    | CNT[15:0]    |            |          |             |             |             |             |        |            |             |             |        |             |        |       |      |   |  |
|        | Reset Value |          |    |    |    |    |    |    |    |    |    |    |    |    |    |    |              |            | 0        | 0           | 0           | 0           | 0           | 0      | 0          | 0           | 0           | 0      | 0           | 0      | 0     |      |   |  |
| 028h   | TIMx_PSC    | Reserved |    |    |    |    |    |    |    |    |    |    |    |    |    |    | PSC[15:0]    |            |          |             |             |             |             |        |            |             |             |        |             |        |       |      |   |  |
|        | Reset Value |          |    |    |    |    |    |    |    |    |    |    |    |    |    |    |              |            | 0        | 0           | 0           | 0           | 0           | 0      | 0          | 0           | 0           | 0      | 0           | 0      | 0     |      |   |  |
| 02Ch   | TIMx_AR     | Reserved |    |    |    |    |    |    |    |    |    |    |    |    |    |    | AR[15:0]     |            |          |             |             |             |             |        |            |             |             |        |             |        |       |      |   |  |
|        | Reset Value |          |    |    |    |    |    |    |    |    |    |    |    |    |    |    |              |            | 1        | 1           | 1           | 1           | 1           | 1      | 1          | 1           | 1           | 1      | 1           | 1      | 1     |      |   |  |
| 030h   | Reserved    |          |    |    |    |    |    |    |    |    |    |    |    |    |    |    |              |            |          |             |             |             |             |        |            |             |             |        |             |        |       |      |   |  |
| 034h   | TIMx_CCDAT1 | Reserved |    |    |    |    |    |    |    |    |    |    |    |    |    |    | CCDAT1[15:0] |            |          |             |             |             |             |        |            |             |             |        |             |        |       |      |   |  |
|        | Reset Value |          |    |    |    |    |    |    |    |    |    |    |    |    |    |    |              |            | 0        | 0           | 0           | 0           | 0           | 0      | 0          | 0           | 0           | 0      | 0           | 0      | 0     |      |   |  |
| 038h   | TIMx_CCDAT2 | Reserved |    |    |    |    |    |    |    |    |    |    |    |    |    |    | CCDAT2[15:0] |            |          |             |             |             |             |        |            |             |             |        |             |        |       |      |   |  |
|        | Reset Value |          |    |    |    |    |    |    |    |    |    |    |    |    |    |    |              |            | 0        | 0           | 0           | 0           | 0           | 0      | 0          | 0           | 0           | 0      | 0           | 0      | 0     |      |   |  |
| 03Ch   | TIMx_CCDAT3 | Reserved |    |    |    |    |    |    |    |    |    |    |    |    |    |    | CCDAT3[15:0] |            |          |             |             |             |             |        |            |             |             |        |             |        |       |      |   |  |
|        | Reset Value |          |    |    |    |    |    |    |    |    |    |    |    |    |    |    |              |            | 0        | 0           | 0           | 0           | 0           | 0      | 0          | 0           | 0           | 0      | 0           | 0      | 0     |      |   |  |
| 040h   | TIMx_CCDAT4 | Reserved |    |    |    |    |    |    |    |    |    |    |    |    |    |    | CCDAT4[15:0] |            |          |             |             |             |             |        |            |             |             |        |             |        |       |      |   |  |
|        | Reset Value |          |    |    |    |    |    |    |    |    |    |    |    |    |    |    |              |            | 0        | 0           | 0           | 0           | 0           | 0      | 0          | 0           | 0           | 0      | 0           | 0      | 0     |      |   |  |
| 044h   | Reserved    |          |    |    |    |    |    |    |    |    |    |    |    |    |    |    |              |            |          |             |             |             |             |        |            |             |             |        |             |        |       |      |   |  |
| 048h   | TIMx_DCTRL  | Reserved |    |    |    |    |    |    |    |    |    |    |    |    |    |    | DBLEN[4:0]   |            |          |             | Reserved    |             | DBADDR[4:0] |        |            |             |             |        |             |        |       |      |   |  |
|        | Reset Value |          |    |    |    |    |    |    |    |    |    |    |    |    |    |    |              |            | 0        | 0           | 0           | 0           | 0           |        |            | 0           | 0           | 0      | 0           | 0      |       |      |   |  |
| 04Ch   | TIMx_DADDR  | Reserved |    |    |    |    |    |    |    |    |    |    |    |    |    |    | BURST[15:0]  |            |          |             |             |             |             |        |            |             |             |        |             |        |       |      |   |  |
|        | Reset Value |          |    |    |    |    |    |    |    |    |    |    |    |    |    |    |              |            | 0        | 0           | 0           | 0           | 0           | 0      | 0          | 0           | 0           | 0      | 0           | 0      | 0     |      |   |  |

## 12.4.2 Control register 1 (TIMx\_CTRL1)

Offset address: 0x00

Reset value: 0x0000 0000

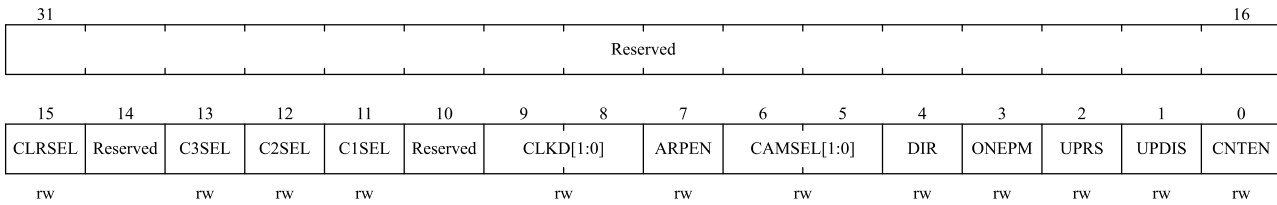

| Bit field | Name     | Description   |
|-----------|----------|---|
| 31:16     | Reserved | Reserved, the reset value must be maintained  |
| 15        | CLRSEL   | OCxREF clear selection<br>0: Select the external OCxREF clear from ETR<br>1: Select the internal OCxREF clear from comparator<br><i>Note: For TIM5, setting to 1 is invalid</i><br><i>Before operating this bit, the extended mode of the chip must be turned on (set PWR_CTRL3.EXMODE)</i> |
| 14        | C4SEL    | Channel 4 Selection<br>0: Select external CH4 (from IOM) signal<br>1: Select internal CH4 (from COMP) signal<br><i>Note: For TIM5, setting to 1 is invalid</i><br><i>Before operating this bit, the extended mode of the chip must be turned on (set PWR_CTRL3.EXMODE)</i>                  |
| 13        | C3SEL    | Channel 3 Selection<br>0: Select external CH3 (from IOM) signal<br>1: Select internal CH3 (from COMP) signal<br><i>Note: Before operating this bit, the extended mode of the chip must be turned on (set PWR_CTRL3.EXMODE)</i>  |
| 12        | C2SEL    | Channel 2 Selection<br>0: Select external CH2 (from IOM) signal<br>1: Select internal CH2 (from COMP) signal<br><i>Note: Before operating this bit, the extended mode of the chip must be turned on (set PWR_CTRL3.EXMODE)</i>  |
| 11        | C1SEL    | Channel 1 selection<br>0: Select external CH1 (from IOM) signal<br>1: Select internal CH1 (from COMP) signal<br><i>Note: Before operating this bit, the extended mode of the chip must be turned on (set PWR_CTRL3.EXMODE)</i>  |
| 10        | Reserved | Reserved, the reset value must be maintained  |

| Bit field | Name        | Description   |
|-----------|-------------|---|
| 9:8       | CLKD[1:0]   | Clock division<br>CLKD[1:0] indicates the division ratio between CK_INT (timer clock) and t <sub>DTS</sub> (clock used for dead-time generator and digital filters (ETR, TIx))<br>00: t <sub>DTS</sub> = t <sub>CK_INT</sub><br>01: t <sub>DTS</sub> = 2 × t <sub>CK_INT</sub><br>10: t <sub>DTS</sub> = 4 × t <sub>CK_INT</sub><br>11: Reserved, do not use this configuration   |
| 7         | ARPEN       | ARPEN: Auto-reload preload enable<br>0: Shadow register disable for TIMx_AR register<br>1: Shadow register enable for TIMx_AR register  |
| 6:5       | CAMSEL[1:0] | Center-aligned mode selection<br>00: Edge-aligned mode. TIMx_CTRL1.DIR specifies up-counting or down-counting.<br>01: Center-aligned mode 1. The counter counts in center-aligned mode, and the output compare interrupt flag bit is set to 1 when down-counting.<br>10: Center-aligned mode 2. The counter counts in center-aligned mode, and the output compare interrupt flag bit is set to 1 when up-counting.<br>11: Center-aligned mode 3. The counter counts in center-aligned mode, and the output compare interrupt flag bit is set to 1 when up-counting or down-counting.<br><i>Note: Switching from edge-aligned mode to center-aligned mode is not allowed when the counter is still enabled (TIMx_CTRL1.CNTEN = 1).</i> |
| 4         | DIR         | Direction<br>0: Up-counting<br>1: Down-counting<br><i>Note: This bit is read-only when the counter is configured in center-aligned mode or encoder mode.</i>  |
| 3         | ONEPM       | One-pulse mode<br>0: Disable one-pulse mode, the counter counts are not affected when an update event occurs.<br>1: Enable one-pulse mode, the counter stops counting when the next update event occurs (clearing TIMx_CTRL1.CNTEN bit)   |
| 2         | UPRS        | Update request source<br>This bit is used to select the UEV event sources by software.<br>0: If update interrupt or DMA request is enabled, any of the following events will generate an update interrupt or DMA request: <ul style="list-style-type: none"> <li>– Counter overflow/underflow</li> <li>– The TIMx_EVTGEN.UDGN bit is set</li> <li>– Update generation from the slave mode controller</li> </ul> 1: If update interrupt or DMA request is enabled, only counter overflow/underflow will generate update interrupt or DMA request   |

| Bit field | Name  | Description   |
|-----------|-------|---|
| 1         | UPDIS | <p>Update disable</p> <p>This bit is used to enable/disable the Update event (UEV) events generation by software.</p> <p>0: Enable UEV. And UEV will be generated if one of following condition been fulfilled:</p> <ul style="list-style-type: none"> <li>– Counter overflow/underflow</li> <li>– The TIMx_EVTGEN.UDGN bit is set</li> <li>– Update generation from the slave mode controller</li> </ul> <p>Shadow registers will update with preload value.</p> <p>1: UEV disabled. No update event is generated, and the shadow registers (AR, PSC, and CCDATx) keep their values. If the TIMx_EVTGEN.UDGN bit is set or a hardware reset is issued by the slave mode controller, the counter and prescaler are reinitialized.</p> |
| 0         | CNTEN | <p>Counter Enable</p> <p>0: Disable counter</p> <p>1: Enable counter</p> <p><i>Note: external clock, gating mode and encoder mode can only work after TIMx_CTRL1.CNTEN bit is set in the software. Trigger mode can automatically set TIMx_CTRL1.CNTEN bit by hardware.</i></p>   |

### 12.4.3 Control register 2 (TIMx\_CTRL2)

Offset address: 0x04

Reset value: 0x0000

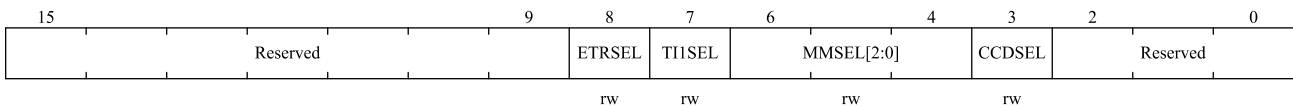

| Bit field | Name     | Description  |
|-----------|----------|--|
| 15:9      | Reserved | Reserved, the reset value must be maintained   |
| 8         | ETRSEL   | <p>External Triggered Selection storage (ETR Selection)</p> <p>0: Select external ETR (from IOM) signal;</p> <p>1: Reserved</p> <p><i>Note: For the mapping of ETR input to IOM, see 7.2.5.7</i></p> <p><i>Before operating this bit, the extended mode of the chip must be turned on (set PWR_CTRL3.EXMODE)</i></p> |
| 7         | TI1SEL   | <p>TI1 selection</p> <p>0: TIMx_CH1 pin connected to TI1 input.</p> <p>1: TIMx_CH1, TIMx_CH2, and TIMx_CH3 pins are XOR connected to the TI1 input.</p>  |

| Bit field | Name       | Description  |
|-----------|------------|--|
| 6:4       | MMSEL[2:0] | <p>Master Mode Selection</p> <p>These 3 bits (TIMx_CTRL2.MMSEL [2:0]) are used to select the synchronization information (TRGO) sent to the slave timer in the master mode. Possible combinations are as follows:</p> <p>000: Reset –When the TIMx_EVTGEN.UDGN is set or a reset is generated by the slave mode controller, a TRGO pulse occurs. And in the latter case, the signal on TRGO is delayed compared to the actual reset.</p> <p>001: Enable - The TIMx_CTRL1.CNTEN bit is used as the trigger output (TRGO). Sometimes you need to start multiple timers at the same time or enable slave timer for a period of time. The counter enable signal is set when TIMx_CTRL1.CNTEN bit is set or the trigger input in gated mode is high.</p> <p>When the counter enable signal is controlled by the trigger input, there is a delay on TRGO except if the master/slave mode is selected (see the description of the TIMx_SMCTRL.MSMD bit).</p> <p>010: Update - The update event is selected as the trigger output (TRGO). For example, a master timer clock can be used as a slave timer prescaler.</p> <p>011: Compare pulse - Triggers the output to send a positive pulse (TRGO) when the TIMx_STS.CC1ITF is to be set (even if it is already high), when a capture or a comparison succeeds.</p> <p>100: Compare - OC1REF signal is used as the trigger output (TRGO).</p> <p>101: Compare - OC2REF signal is used as the trigger output (TRGO).</p> <p>110: Compare - OC3REF signal is used as the trigger output (TRGO).</p> <p>111: Compare - OC4REF signal is used as the trigger output (TRGO).</p> |
| 3         | CCDSEL     | <p>Capture/compare DMA selection</p> <p>0: When a CCx event occurs, a DMA request for CCx is sent.</p> <p>1: When an update event occurs, a DMA request for CCx is sent.</p>   |
| 2:0       | Reserved   | Reserved, the reset value must be maintained   |

### 12.4.4 Slave mode control register (TIMx\_SMCTRL)

Offset address: 0x08

Reset value: 0x0000

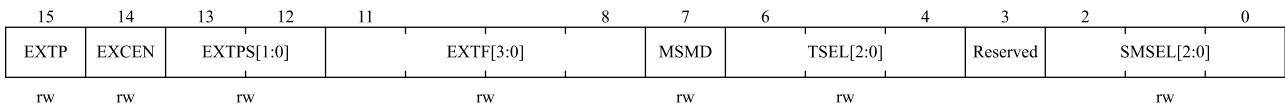

| Bit field | Name  | Description   |
|-----------|-------|---|
| 15        | EXTP  | <p>External trigger polarity</p> <p>This bit is used to select whether the trigger operation is to use ETR or the inversion of ETR.</p> <p>0: ETR active at high level or rising edge.</p> <p>1: ETR active at low level or falling edge.</p> |
| 14        | EXCEN | <p>External clock enable</p> <p>This bit is used to enable external clock mode 2, and the counter is driven by any active edge on the ETRF signal in this mode.</p>   |

| Bit field | Name       | Description   |
|-----------|------------|---|
|           |            | 0: External clock mode 2 disable.<br>1: External clock mode 2 enable.<br><i>Note 1: When external clock mode 1 and external clock mode 2 are enabled at the same time, the input of the external clock is ETRF.</i><br><i>Note 2: The following slave modes can be used simultaneously with external clock mode 2: reset mode, gated mode and trigger mode; However, TRGI cannot connect to ETRF (TIMx_SMCTRL.TSEL ≠ '111').</i><br><i>Note 3: Setting the TIMx_SMCTRL.EXCEN bit has the same effect as selecting external clock mode 1 and connecting TRGI to ETRF (TIMx_SMCTRL.SMSEL = 111 and TIMx_SMCTRL.TSEL = 111).</i>   |
| 13:12     | EXTPS[1:0] | External trigger prescaler<br>The frequency of the external trigger signal ETRP must be at most 1/4 of TIMxCLK frequency.<br>When a faster external clock is input, a prescaler can be used to reduce the frequency of ETRP.<br>00: Prescaler disable<br>01: ETRP frequency divided by 2<br>10: ETRP frequency divided by 4<br>11: ETRP frequency divided by 8  |
| 11:8      | EXTF[3:0]  | External trigger filter<br>These bits are used to define the frequency at which the ETRP signal is sampled and the bandwidth of the ETRP digital filtering. In effect, the digital filter is an event counter that generates a validate output after consecutive N events are recorded.<br>0000: No filter, sampling at f <sub>DTS</sub><br>0001: f <sub>SAMPLING</sub> = f <sub>CK_INT</sub> , N = 2<br>0010: f <sub>SAMPLING</sub> = f <sub>CK_INT</sub> , N = 4<br>0011: f <sub>SAMPLING</sub> = f <sub>CK_INT</sub> , N = 8<br>0100: f <sub>SAMPLING</sub> = f <sub>DTS</sub> /2, N = 6<br>0101: f <sub>SAMPLING</sub> = f <sub>DTS</sub> /2, N = 8<br>0110: f <sub>SAMPLING</sub> = f <sub>DTS</sub> /4, N = 6<br>0111: f <sub>SAMPLING</sub> = f <sub>DTS</sub> /4, N = 8<br>1000: f <sub>SAMPLING</sub> = f <sub>DTS</sub> /8, N = 6<br>1001: f <sub>SAMPLING</sub> = f <sub>DTS</sub> /8, N = 8<br>1010: f <sub>SAMPLING</sub> = f <sub>DTS</sub> /16, N = 5<br>1011: f <sub>SAMPLING</sub> = f <sub>DTS</sub> /16, N = 6<br>1100: f <sub>SAMPLING</sub> = f <sub>DTS</sub> /16, N = 8<br>1101: f <sub>SAMPLING</sub> = f <sub>DTS</sub> /32, N = 5<br>1110: f <sub>SAMPLING</sub> = f <sub>DTS</sub> /32, N = 6<br>1111: f <sub>SAMPLING</sub> = f <sub>DTS</sub> /32, N = 8 |
| 7         | MSMD       | Master/ Slave mode<br>0: No action<br>1: Events on the trigger input (TRGI) are delayed to allow a perfect synchronization between the current timer (via TRGO) and its slaves. This is useful when several timers are required to be synchronized to a single external event.  |

| Bit field | Name       | Description  |
|-----------|------------|--|
| 6:4       | TSEL[2:0]  | <p>Trigger selection</p> <p>These 3 bits are used to select the trigger input of the synchronous counter.</p> <p>000: Internal trigger 0 (ITR0) 100: TI1 edge detector (TI1F_ED)<br/>           001: Internal trigger 1 (ITR1) 101: Filtered timer input 1 (TI1FP1)<br/>           010: Internal trigger 2 (ITR2) 110: Filtered timer input 2 (TI2FP2)<br/>           011: Internal trigger 3 (ITR3) 111: External triggered Input (ETRF)</p> <p>For more details on ITRx, see Table 12-3 below.</p> <p><i>Note: These bits must be changed only when not in use (e. g. TIMx_SMCTRL.SMSEL=000) to avoid false edge detection at the transition.</i></p>  |
| 3         | Reserved   | Reserved, the reset value must be maintained   |
| 2:0       | SMSEL[2:0] | <p>Slave mode selection</p> <p>When an external signal is selected, the active edge of the trigger signal (TRGI) is linked to the selected external input polarity (see input control register and control register description)</p> <p>000: Disable slave mode. If TIMx_CTRL1.CNTEN = 1, the prescaler is driven directly by the internal clock.</p> <p>001: Encoder mode 1. According to the level of TI2FP2, the counter up-counting or down-counting on the edge of TI1FP1.</p> <p>010: Encoder mode 2. According to the level of TI1FP1, the counter up-counting or down-counting on the edge of TI2FP2.</p> <p>011: Encoder mode 3. According to the input level of another signal, the counter up-counting or down-counting on the edges of TI2FP1 and TI2FP2.</p> <p>100: Reset mode. On the rising edge of the selected trigger input (TRGI), the counter is reinitialized and the shadow register is updated.</p> <p>101: Gated mode. When the trigger input (TRGI) is high, the clock of the counter is enabled. Once the trigger input becomes low, the counter stops counting, but is not reset. In this mode, the start and stop of the counter are controlled.</p> <p>110: Trigger mode. When a rising edge occurs on the trigger input (TRGI), the counter is started but not reset. In this mode, only the start of the counter is controlled.</p> <p>111: External clock mode 1. The counter is clocked by the rising edge of the selected trigger input (TRGI).</p> <p><i>Note: Do not use gated mode if TI1F_ED is selected as the trigger input (TIMx_SMCTRL.TSEL=100). This is because TI1F_ED outputs a pulse for each TI1F transition, whereas gated mode checks the level of the triggered input.</i></p> |

Table 12-3 TIMx internal trigger connection

| Slave timer | ITR0 (TSEL = 000) | ITR1 (TSEL = 001) | ITR2 (TSEL = 010) | ITR3 (TSEL = 011) |
|-------------|-------------------|-------------------|-------------------|-------------------|
| <b>TIM2</b> | TIM1              | TIM8              | TIM3              | TIM4              |
| <b>TIM3</b> | TIM1              | TIM2              | TIM5              | TIM4              |
| <b>TIM4</b> | TIM1              | TIM2              | TIM3              | TIM8              |
| <b>TIM5</b> | TIM2              | TIM3              | TIM4              | TIM8              |

## 12.4.5 DMA/Interrupt enable registers (TIMx\_DINTEN)

Offset address: 0x0C

Reset value: 0x0000

|          |      |          |        |        |        |        |      |          |      |          |        |        |        |        |      |
|----------|------|----------|--------|--------|--------|--------|------|----------|------|----------|--------|--------|--------|--------|------|
| 15       | 14   | 13       | 12     | 11     | 10     | 9      | 8    | 7        | 6    | 5        | 4      | 3      | 2      | 1      | 0    |
| Reserved | TDEN | Reserved | CC4DEN | CC3DEN | CC2DEN | CC1DEN | UDEN | Reserved | TIEN | Reserved | CC4IEN | CC3IEN | CC2IEN | CC1IEN | UIEN |
|          | rw   |          | rw     | rw     | rw     | rw     | rw   |          | rw   |          | rw     | rw     | rw     | rw     | rw   |

| Bit field | Name     | Description   |
|-----------|----------|---|
| 15        | Reserved | Reserved, the reset value must be maintained  |
| 14        | TDEN     | Trigger DMA request enable<br>0: Disable trigger DMA request<br>1: Enable trigger DMA request                               |
| 13        | Reserved | Reserved, the reset value must be maintained  |
| 12        | CC4DEN   | Capture/Compare 4 DMA request enable<br>0: Disable capture/compare 4 DMA request<br>1: Enable capture/compare 4 DMA request |
| 11        | CC3DEN   | Capture/Compare 3 DMA request enable<br>0: Disable capture/compare 3 DMA request<br>1: Enable capture/compare 3 DMA request |
| 10        | CC2DEN   | Capture/Compare 2 DMA request enable<br>0: Disable capture/compare 2 DMA request<br>1: Enable capture/compare 2 DMA request |
| 9         | CC1DEN   | Capture/Compare 1 DMA request enable<br>0: Disable capture/compare 1 DMA request<br>1: Enable capture/compare 1 DMA request |
| 8         | UDEN     | Update DMA request enable<br>0: Disable update DMA request<br>1: Enable update DMA request                                  |
| 7         | Reserved | Reserved, the reset value must be maintained  |
| 6         | TIEN     | Trigger interrupt enable<br>0: Disable trigger interrupt<br>1: Enable trigger interrupt                                     |
| 5         | Reserved | Reserved, the reset value must be maintained  |
| 4         | CC4IEN   | Capture/Compare 4 interrupt enable<br>0: Disable capture/compare 4 interrupt<br>1: Enable capture/compare 4 interrupt       |
| 3         | CC3IEN   | Capture/Compare 3 interrupt enable<br>0: Disable capture/compare 3 interrupt<br>1: Enable capture/compare 3 interrupts      |
| 2         | CC2IEN   | Capture/Compare 2 interrupt enable<br>0: Disable capture/compare 2 interrupt  |

| Bit field | Name   | Description  |
|-----------|--------|--|
|           |        | 1: Enables capture/compare 2 interrupts  |
| 1         | CC1IEN | Capture/Compare 1 interrupt enable<br>0: Disable capture/compare 1 interrupt<br>1: Enables capture/comparing 1 interrupt |
| 0         | UIEN   | Update interrupt enable<br>0: Disable update interrupt<br>1: Enables update interrupt                                    |

## 12.4.6 Status registers (TIMx\_STS)

Offset address: 0x10

Reset value: 0x0000

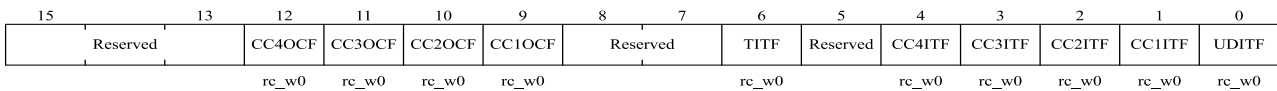

| Bit field | Name     | Description  |
|-----------|----------|--|
| 15:13     | Reserved | Reserved, the reset value must be maintained   |
| 12        | CC4OCF   | Capture/Compare 4 overcapture flag<br>See TIMx_STS.CC1OCF description.   |
| 11        | CC3OCF   | Capture/Compare 3 overcapture flag<br>See TIMx_STS.CC1OCF description.   |
| 10        | CC2OCF   | Capture/Compare 2 overcapture flags<br>See TIMx_STS.CC1OCF description.  |
| 9         | CC1OCF   | Capture/Compare 1 overcapture flag<br>This bit is set by hardware only when the corresponding channel is configured in input capture mode. Cleared by software writing 0.<br>0: No overcapture occurred<br>1: TIMx_STS.CC1ITF was already set when the value of the counter has been captured in the TIMx_CCDAT1 register.                   |
| 8:7       | Reserved | Reserved, the reset value must be maintained   |
| 6         | TITF     | Trigger interrupt flag<br>This bit is set by hardware when an active edge is detected on the TRGI input when the slave mode controller is in a mode other than gated. This bit is set by hardware when any edge in gated mode is detected. This bit is cleared by software.<br>0: No trigger event occurred<br>1: Trigger interrupt occurred |
| 5         | Reserved | Reserved, the reset value must be maintained   |
| 4         | CC4ITF   | Capture/Compare 4 interrupt flag<br>See TIMx_STS.CC1ITF description.   |

| Bit field | Name   | Description  |
|-----------|--------|--|
| 3         | CC3ITF | Capture/Compare 3 interrupt flag<br>See TIMx_STS.CC1ITF description.   |
| 2         | CC2ITF | Capture/Compare 2 interrupt flag<br>See TIMx_STS.CC1ITF description.   |
| 1         | CC1ITF | <p>Capture/Compare 1 interrupt flag</p> <p><b>When the corresponding channel of CC1 is in output mode:</b></p> <p>Except in center-aligned mode, this bit is set by hardware when the counter value is the same as the compare value (see TIMx_CTRL1.CAMSEL bit description). This bit is cleared by software.</p> <p>0: No match occurred.</p> <p>1: The value of TIMx_CNT is the same as the value of TIMx_CC1.</p> <p>When the value of TIMx_CC1 is greater than the value of TIMx_ARR, the TIMx_STS.CC1ITF bit will go high if the counter overflows (in up-counting and up/down-counting modes) and underflows in down-counting mode.</p> <p><b>When the corresponding channel of CC1 is in input mode:</b></p> <p>This bit is set by hardware when the capture event occurs. This bit is cleared by software or by reading TIMx_CC1.</p> <p>0: No input capture occurred.</p> <p>1: Input capture occurred. Counter value has captured in the TIMx_CC1. An edge with the same polarity as selected has been detected on IC1.</p> |
| 0         | UDITF  | <p>Update interrupt flag</p> <p>This bit is set by hardware when an update event occurs under the following conditions:</p> <ul style="list-style-type: none"> <li>– When TIMx_CTRL1.UPDIS = 0, overflow or underflow (An update event is generated).</li> <li>– When TIMx_CTRL1.UPRS = 0, TIMx_CTRL1.UPDIS = 0, and set the TIMx_EVTGEN.UDGN bit by software to reinitialize the CNT.</li> <li>– When TIMx_CTRL1.UPRS = 0, TIMx_CTRL1.UPDIS = 0, and the counter CNT is reinitialized by the trigger event. (See TIMx_SMCTRL Register description)</li> </ul> <p>This bit is cleared by software.</p> <p>0: No update event occurred</p> <p>1: Update interrupt occurred</p>  |

## 12.4.7 Event generation registers (TIMx\_EVTGEN)

Offset address: 0x14

Reset values: 0 x0000



| Bit field | Name     | Description                                   |
|-----------|----------|---|
| 15: 7     | Reserved | Reserved, the reset value must be maintained. |

| Bit field | Name     | Description   |
|-----------|----------|---|
| 6         | TGN      | Trigger generation<br>This bit can generate a trigger event when set by software. And at this time TIMx_STS.TITF = 1, if the corresponding interrupt and DMA are enabled, the corresponding interrupt and DMA will be generated. This bit is automatically cleared by hardware.<br>0: No action<br>1: Generated a trigger event   |
| 5         | Reserved | Reserved, the reset value must be maintained  |
| 4         | CC4GN    | Capture/Compare 4 generation<br>See TIMx_EVTGEN.CC1GN description.  |
| 3         | CC3GN    | Capture/Compare 3 generation<br>See TIMx_EVTGEN.CC1GN description.  |
| 2         | CC2GN    | Capture/Compare 2 generation<br>See TIMx_EVTGEN.CC1GN description.  |
| 1         | CC1GN    | Capture/Compare 1 generation<br>This bit can generate a capture/compare event when set by software. This bit is automatically cleared by hardware.<br>When the corresponding channel of CC1 is in output mode:<br>The TIMx_STS.CC1ITF flag will be pulled high, if the corresponding interrupt and DMA are enabled, the corresponding interrupt and DMA will be generated.<br>When the corresponding channel of CC1 is in input mode:<br>TIMx_CC1DAT1 will capture the current counter value, and the TIMx_STS.CC1ITF flag will be pulled high, if the corresponding interrupt and DMA are enabled, the corresponding interrupt and DMA will be generated. If The IMx_STS.CC1ITF is already pulled high, pull TIMx_STS.CC1OCF high.<br>0: No action<br>1: Generated a CC1 capture/compare event |
| 0         | UDGN     | Update generation<br>This bit can generate an update event when set by software. And at this time the counter will be reinitialized, the prescaler counter will be cleared, the counter will be cleared in center-aligned or up-counting mode, but take TIMx_AR in down-counting mode the value of the register. This bit is automatically cleared by hardware.<br>0: No action<br>1: Generated an update event   |

### 12.4.8 Capture/compare mode register 1 (TIMx\_CCMOD1)

Offset address: 0x18

Reset value: 0x0000

Channels can be used for input (capture mode) or output (compare mode), and the direction of the channel is defined by the corresponding CCxSEL bit. The other bits of the register act differently in input and output modes. OCx describes the function of a channel in output mode, ICx describes the function of a channel in input mode. Hence, please note that the same bit can have different meanings for output mode and for input mode.

## Output compare mode:

|        |            |    |        |        |             |   |        |            |   |        |        |             |   |
|--------|------------|----|--------|--------|-------------|---|--------|------------|---|--------|--------|-------------|---|
| 15     | 14         | 12 | 11     | 10     | 9           | 8 | 7      | 6          | 4 | 3      | 2      | 1           | 0 |
| OC2CEN | OC2MD[2:0] |    | OC2PEN | OC2FEN | CC2SEL[1:0] |   | OC1CEN | OC1MD[2:0] |   | OC1PEN | OC1FEN | CC1SEL[1:0] |   |
| rw     | rw         |    | rw     | rw     | rw          |   | rw     | rw         |   | rw     | rw     | rw          |   |

| Bit field | Name        | Description  |
|-----------|-------------|--|
| 15        | OC2CEN      | Output Compare 2 clear enable  |
| 14:12     | OC2MD[2:0]  | Output Compare 2 mode  |
| 11        | OC2PEN      | Output Compare 2 preload enable  |
| 10        | OC2FEN      | Output Compare 2 fast enable   |
| 9:8       | CC2SEL[1:0] | Capture/compare 2 selection<br>These bits are used to select the input/output and input mapping of the channel<br>00: CC2 channel is configured as output<br>01: CC2 channel is configured as input, IC2 is mapped on TI2<br>10: CC2 channel is configured as input, IC2 is mapped on TI1<br>11: CC2 channel is configured as input, IC2 is mapped on TRC. This mode is only active when the internal trigger input is selected by TIMx_SMCTRL.TSEL.<br><i>Note: CC2SEL is writable only when the channel is off (TIMx_CCEN.CC2EN = 0).</i>  |
| 7         | OC1CEN      | Output Compare 1 clear enable<br>0: OC1REF is not affected by ETRF input level<br>1: OC1REF is cleared immediately when the ETRF input level is detected as high   |
| 6:4       | OC1MD[2:0]  | Output Compare 1 mode<br>These bits are used to manage the output reference signal OC1REF, which determines the values of OC1 and OC1N, and is valid at high levels, while the active levels of OC1 and OC1N depend on the TIMx_CCEN.CC1P and TIMx_CCEN.CC1NP bits.<br>000: Frozen. Comparison between TIMx_CC DAT1 register and counter TIMx_CNT has no effect on OC1REF signal.<br>001: Set channel 1 to the active level on match. When TIMx_CC DAT1 = TIMx_CNT, OC1REF signal will be forced high.<br>010: Set channel 1 as inactive level on match. When TIMx_CC DAT1 = TIMx_CNT, OC1REF signal will be forced low.<br>011: Toggle. When TIMx_CC DAT1 = TIMx_CNT, OC1REF signal will be toggled.<br>100: Force to inactive level. OC1REF signal is forced low.<br>101: Force to active level. OC1REF signal is forced high.<br>110: PWM mode 1 - In up-counting mode, if TIMx_CNT < TIMx_CC DAT1, OC1REF signal of channel 1 is high, otherwise it is low. In down-counting mode, if TIMx_CNT > TIMx_CC DAT1, OC1REF signal of channel 1 is low, otherwise it is high.<br>111: PWM mode 2 - In up-counting mode, if TIMx_CNT < TIMx_CC DAT1, OC1REF signal of channel 1 is low, otherwise it is high. In down-counting mode, if TIMx_CNT > TIMx_CC DAT1, OC1REF signal of channel 1 is high, otherwise it is low.<br><i>Note 1: In PWM mode 1 or PWM mode 2, the OC1REF level changes only when the comparison result changes or when the output compare mode is switched from frozen mode to PWM mode.</i> |

| Bit field | Name        | Description   |
|-----------|-------------|---|
| 3         | OC1PEN      | <p>Output Compare 1 preload enable</p> <p>0: Disable preload function of TIMx_CC DAT1 register. Supports write operations to TIMx_CC DAT1 register at any time, and the written value is effective immediately.</p> <p>1: Enable preload function of TIMx_CC DAT1 register. Only read and write operations to preload registers. When an update event occurs, the value of TIMx_CC DAT1 is loaded into the active register.</p> <p><i>Note 1: Only when TIMx_CTRL1.ONEPM = 1(In one-pulse mode), PWM mode can be used without verifying the preload register, otherwise no other behavior can be predicted.</i></p>   |
| 2         | OC1FEN      | <p>Output Compare 1 fast enable</p> <p>This bit is used to speed up the response of the CC output to the trigger input event.</p> <p>0: CC1 behaves normally depending on the counter and CC DAT1 values, even if the trigger is ON. The minimum delay for activating CC1 output when an edge occurs on the trigger input is 5 clock cycles.</p> <p>1: An active edge of the trigger input acts like a comparison match on CC1 output. Therefore, OC is set to the comparison level regardless of the comparison result. The delay time for sampling the trigger input and activating the CC1 output is reduced to 3 clock cycles.</p> <p>OCx FEN only works if the channel is configured in PWM1 or PWM2 mode.</p> |
| 1: 0      | CC1SEL[1:0] | <p>Capture/compare 1 selection</p> <p>These bits are used to select the input/output and input mapping of the channel</p> <p>00: CC1 channel is configured as output</p> <p>01: CC1 channel is configured as input, IC1 is mapped on TI1</p> <p>10: CC1 channel is configured as input, IC1 is mapped on TI2</p> <p>11: CC1 channels are configured as inputs and IC1 is mapped to TRC. This mode is only active when the internal trigger input is selected by TIMx_SM CTRL.TSEL.</p> <p><i>Note: CC1SEL is writable only when the channel is off (TIMx_CCEN.CC1EN = 0).</i></p>   |

#### Input capture mode:

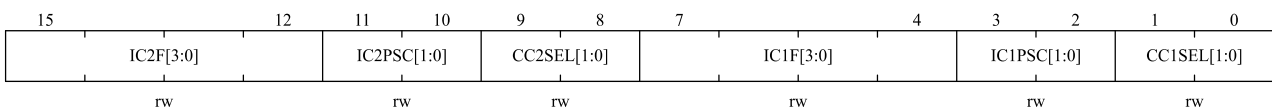

| Bit field | Name        | Description   |
|-----------|-------------|---|
| 15:12     | IC2F[3:0]   | Input Capture 2 Filter  |
| 11:10     | IC2PSC[1:0] | Input Capture 2 Prescaler   |
| 9:8       | CC2SEL[1:0] | <p>Capture/Compare 2 selection</p> <p>These bits are used to select the input/output and input mapping of the channel</p> <p>00: CC2 channel is configured as output</p> <p>01: CC2 channel is configured as input, IC2 is mapped on TI2</p> <p>10: CC2 channel is configured as input, IC2 is mapped on TI1</p> <p>11: CC2 channel is configured as input, IC2 is mapped on TRC. This mode is only active when the internal trigger input is selected by TIMx_SM CTRL.TSEL.</p> <p><i>Note: CC2SEL is writable only when the channel is off (TIMx_CCEN.CC2EN = 0).</i></p> |

| Bit field | Name        | Description   |
|-----------|-------------|---|
| 7:4       | IC1F[3:0]   | <p>Input Capture 1 filter</p> <p>These bits are used to define sampling frequency of TI1 input and the length of digital filter. The digital filter is an event counter that generates an output transition after N events are recorded.</p> <p>0000: No filter, sampling at <math>f_{DTS}</math> frequency</p> <p>0001: <math>f_{SAMPLING} = f_{CK\_INT}, N = 2</math></p> <p>0010: <math>f_{SAMPLING} = f_{CK\_INT}, N = 4</math></p> <p>0011: <math>f_{SAMPLING} = f_{CK\_INT}, N = 8</math></p> <p>0100: <math>f_{SAMPLING} = f_{DTS}/2, N = 6</math></p> <p>0101: <math>f_{SAMPLING} = f_{DTS}/2, N = 8</math></p> <p>0110: <math>f_{SAMPLING} = f_{DTS}/4, N = 6</math></p> <p>0111: <math>f_{SAMPLING} = f_{DTS}/4, N = 8</math></p> <p>1000: <math>f_{SAMPLING} = f_{DTS}/8, N = 6</math></p> <p>1001: <math>f_{SAMPLING} = f_{DTS}/8, N = 8</math></p> <p>1010: <math>f_{SAMPLING} = f_{DTS}/16, N = 5</math></p> <p>1011: <math>f_{SAMPLING} = f_{DTS}/16, N = 6</math></p> <p>1100: <math>f_{SAMPLING} = f_{DTS}/16, N = 8</math></p> <p>1101: <math>f_{SAMPLING} = f_{DTS}/32, N = 5</math></p> <p>1110: <math>f_{SAMPLING} = f_{DTS}/32, N = 6</math></p> <p>1111: <math>f_{SAMPLING} = f_{DTS}/32, N = 8</math></p> |
| 3:2       | IC1PSC[1:0] | <p>Input Capture 1 prescaler</p> <p>These bits are used to select the ratio of the prescaler for IC1 (CC1 input).</p> <p>When <math>TIMx\_CCEN.CC1EN = 0</math>, the prescaler will be reset.</p> <p>00: No prescaler, capture is done each time an edge is detected on the capture input</p> <p>01: Capture is done once every 2 events</p> <p>10: Capture is done once every 4 events</p> <p>11: Capture is done once every 8 events</p>  |
| 1:0       | CC1SEL[1:0] | <p>Capture/Compare 1 selection</p> <p>These bits are used to select the input/output and input mapping of the channel</p> <p>00: CC1 channel is configured as output</p> <p>01: CC1 channel is configured as input, IC1 is mapped on TI1</p> <p>10: CC1 channel is configured as input, IC1 is mapped on TI2</p> <p>11: CC1 channel is configured as input, IC1 is mapped to TRC. This mode is only active when the internal trigger input is selected by <math>TIMx\_SMCTRL.TSEL</math>.</p> <p><i>Note: CC1SEL is writable only when the channel is off (<math>TIMx\_CCEN.CC1EN = 0</math>).</i></p>  |

## 12.4.9 Capture/compare mode register 2 (TIMx\_CCMOD2)

Offset address: 0x1C

Reset value: 0x0000

See the description of the CCMOD1 register above

Output comparison mode:

|        |            |        |        |             |        |            |        |        |             |   |   |   |   |
|--------|------------|--------|--------|-------------|--------|------------|--------|--------|-------------|---|---|---|---|
| 15     | 14         | 12     | 11     | 10          | 9      | 8          | 7      | 6      | 4           | 3 | 2 | 1 | 0 |
| OC4CEN | OC4MD[2:0] | OC4PEN | OC4FEN | CC4SEL[1:0] | OC3CEN | OC3MD[2:0] | OC3PEN | OC3FEN | CC3SEL[1:0] |   |   |   |   |
| rw     | rw         | rw     | rw     | rw          | rw     | rw         | rw     | rw     | rw          |   |   |   |   |

| Bit field | Name        | Description   |
|-----------|-------------|---|
| 15        | OC4CEN      | Output compare 4 clear enable   |
| 14:12     | OC4MD[2:0]  | Output compare 4 mode   |
| 11        | OC4PEN      | Output compare 4 preload enable   |
| 10        | OC4FEN      | Output compare 4 fast enable  |
| 9:8       | CC4SEL[1:0] | Capture/Compare 4 selection<br>These bits are used to select the input/output and input mapping of the channel<br>00: CC4 channel is configured as output<br>01: CC4 channel is configured as input, IC4 is mapped on TI4<br>10: CC4 channel is configured as input, IC4 is mapped on TI3<br>11: CC4 channel is configured as input, IC4 is mapped on TRC. This mode is only active when the internal trigger input is selected by TIMx_SMCTRL.TSEL.<br><i>Note: CC4SEL is writable only when the channel is off (TIMx_CCEN.CC4EN = 0).</i> |
| 7         | OC3CEN      | Output compare 3 clear enable   |
| 6:4       | OC3MD[2:0]  | Output compare 3 mode   |
| 3         | OC3PEN      | Output compare 3 preload enable   |
| 2         | OC3FEN      | Output compare 3 fast enable  |
| 1:0       | CC3SEL[1:0] | Capture/Compare 3 selection<br>These bits are used to select the input/output and input mapping of the channel<br>00: CC3 channel is configured as output<br>01: CC3 channel is configured as input, IC3 is mapped to TI3<br>10: CC3 channel is configured as input, IC3 is mapped on TI4<br>11: CC3 channel is configured as input, IC3 is mapped to TRC. This mode is only active when the internal trigger input is selected by TIMx_SMCTRL.TSEL.<br><i>Note: CC3SEL is writable only when the channel is off (TIMx_CCEN.CC3EN = 0).</i> |

**Input capture mode:**

|           |             |             |           |             |             |   |   |   |   |   |   |
|-----------|-------------|-------------|-----------|-------------|-------------|---|---|---|---|---|---|
| 15        | 12          | 11          | 10        | 9           | 8           | 7 | 4 | 3 | 2 | 1 | 0 |
| IC4F[3:0] | IC4PSC[1:0] | CC4SEL[1:0] | IC3F[3:0] | IC3PSC[1:0] | CC3SEL[1:0] |   |   |   |   |   |   |
| rw        | rw          | rw          | rw        | rw          | rw          |   |   |   |   |   |   |

| Bit field | Name        | Description               |
|-----------|-------------|---------------------------|
| 15:12     | IC4F[3:0]   | Input Capture 4 filter    |
| 11:10     | IC4PSC[1:0] | Input Capture 4 Prescaler |

| Bit field | Name        | Description   |
|-----------|-------------|---|
| 9:8       | CC4SEL[1:0] | Capture/Compare 4 selection<br>These bits are used to select the input/output and input mapping of the channel<br>00: CC4 channel is configured as output<br>01: CC4 channel is configured as input, IC4 is mapped on TI4<br>10: CC4 channel is configured as input, IC4 is mapped on TI3<br>11: CC4 channel is configured as input, IC4 is mapped on TRC. This mode is only active when the internal trigger input is selected by TIMx_SMCTRL.TSEL.<br><i>Note: CC4SEL is writable only when the channel is off (TIMx_CCEN.CC4EN = 0).</i> |
| 7:4       | IC3F[3:0]   | Input Capture 3 filter  |
| 3:2       | IC3PSC[1:0] | Input Capture 3 Prescaler   |
| 1:0       | CC3SEL[1:0] | Capture/compare 3 selection<br>These bits are used to select the input/output and input mapping of the channel<br>00: CC3 channel is configured as output<br>01: CC3 channel is configured as input, IC3 is mapped to TI3<br>10: CC3 channel is configured as input, IC3 is mapped on TI4<br>11: CC3 channel is configured as input, IC3 is mapped to TRC. This mode is only active when the internal trigger input is selected by TIMx_SMCTRL.TSEL.<br><i>Note: CC3SEL is writable only when the channel is off (TIMx_CCEN.CC3EN = 0).</i> |

### 12.4.10 Capture/compare enable registers (TIMx\_CCEN)

Offset address: 0x20

Reset value: 0x0000

|          |    |      |       |          |    |      |       |          |   |      |       |          |   |       |       |
|----------|----|------|-------|----------|----|------|-------|----------|---|------|-------|----------|---|-------|-------|
| 15       | 14 | 13   | 12    | 11       | 10 | 9    | 8     | 7        | 6 | 5    | 4     | 3        | 2 | 1     | 0     |
| Reserved |    | CC4P | CC4EN | Reserved |    | CC3P | CC3EN | Reserved |   | CC2P | CC2EN | Reserved |   | CC1OP | CC1EN |
|          |    | rw   | rw    |          |    | rw   | rw    |          |   | rw   | rw    |          |   | rw    | rw    |

| Bit field | Name     | Description  |
|-----------|----------|--|
| 15:14     | Reserved | Reserved, the reset value must be maintained.                        |
| 13        | CC4P     | Capture/Compare 4 output polarity<br>See TIMx_CCEN.CC1P description. |
| 12        | CC4EN    | Capture/Compare 4 output enable<br>See TIMx_CCEN.CC1EN description.  |
| 11:10     | Reserved | Reserved, the reset value must be maintained                         |
| 9         | CC3P     | Capture/Compare 3 output polarity<br>See TIMx_CCEN.CC1P description. |
| 8         | CC3EN    | Capture/Compare 3 output enable<br>See TIMx_CCEN.CC1EN description.  |
| 7:6       | Reserved | Reserved, the reset value must be maintained                         |

| Bit field | Name     | Description  |
|-----------|----------|--|
| 5         | CC2P     | Capture/Compare 2 output polarity<br>See TIMx_CCEN.CC1P description.   |
| 4         | CC2EN    | Capture/Compare 2 output enable<br>See TIMx_CCEN.CC1EN description.  |
| 3:2       | Reserved | Reserved, the reset value must be maintained   |
| 1         | CC1P     | Capture/Compare 1 output polarity<br>When the corresponding channel of CC1 is in output mode:<br>0: OC1 active high<br>1: OC1 active low<br>When the corresponding channel of CC1 is in input mode:<br>At this time, this bit is used to select whether IC1 or the inverse signal of IC1 is used as the trigger or capture signal.<br>0: non-inverted: Capture action occurs when IC1 generates a rising edge. When used as external trigger, IC1 is non-inverted.<br>1: inverted: Capture action occurs when IC1 generates a falling edge. When used as external trigger, IC1 is inverted.<br><i>Note: If TIMx_BKDT.LCKCFG = 3 or 2, these bits cannot be modified.</i> |
| 0         | CC1EN    | Capture/Compare 1 output enable<br>When the corresponding channel of CC1 is in output mode:<br>0: Disable - Disable output OC1 signal.<br>1: Enable - Enable output OC1 signal.<br>When the corresponding channel of CC1 is in input mode:<br>At this time, this bit is used to disable/enable the capture function.<br>0: Disable capture<br>1: Enable capture  |

Table 12-4 Output control bits of standard OCx channel

| CCxEN | OCx output status       |
|-------|-------------------------|
| 0     | Disable output (OCx=0)  |
| 1     | OCx = OCxREF + polarity |

*Note: The state of external I/O pins connected to standard OCx channels depends on the OCx channel state and GPIO and AFIO registers.*

### 12.4.11 Counters (TIMx\_CNT)

Offset address: 0x24

Reset value: 0x0000

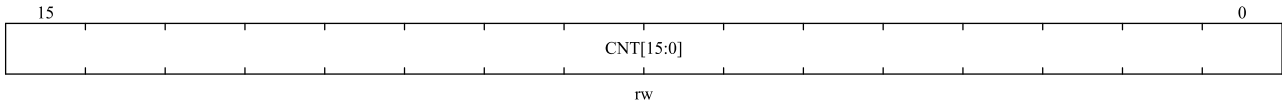

| Bit field | Name      | Description   |
|-----------|-----------|---------------|
| 15:0      | CNT[15:0] | Counter value |

### 12.4.12 Prescaler (TIMx\_PSC)

Offset address: 0x28

Reset value: 0x0000

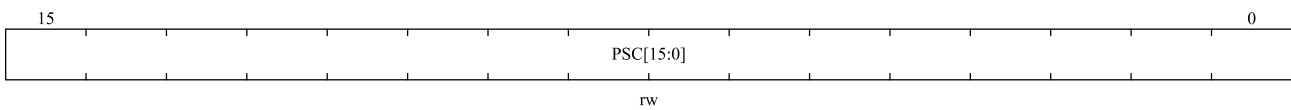

| Bit field | Name      | Description  |
|-----------|-----------|--|
| 15:0      | PSC[15:0] | Prescaler value<br>Counter clock $f_{CK\_CNT} = f_{CK\_PSC} / (PSC [15:0] + 1)$ .<br>Each time an update event occurs, the PSC value is loaded into the active prescaler register. |

### 12.4.13 Auto-reload register (TIMx\_AR)

Offset address: 0x2C

Reset values: 0xFFFF



| Bit field | Name     | Description  |
|-----------|----------|--|
| 15:0      | AR[15:0] | Auto-reload value<br>These bits define the value that will be loaded into the actual auto-reload register.<br>See Section 12.3.1 for more details.<br>When the TIMx_AR.AR [15:0] value is null, the counter does not work. |

### 12.4.14 Capture/compare register 1 (TIMx\_CCDAT1)

Offset address: 0x34

Reset value: 0x0000

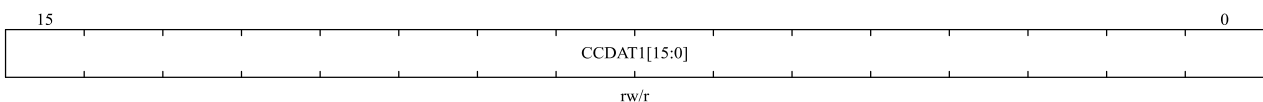

| Bit field | Name         | Description  |
|-----------|--------------|--|
| 15:0      | CCDAT1[15:0] | <p>Capture/Compare 1 value</p> <ul style="list-style-type: none"> <li>CC1 channel is configured as output:<br/>CCDAT1 contains the value to be compared to the counter TIMx_CNT, signaling on the OC1 output.<br/>If the preload feature is not selected in TIMx_CCMOD1.OC1PEN bit, the written value is immediately transferred to the active register. Otherwise, this preloaded value is transferred to the active register only when an update event occurs.</li> <li>CC1 channel is configured as input:<br/>CCDAT1 contains the counter value transferred by the last input capture 1 event (IC1).<br/>When configured as input mode, register CCDAT1 is only readable.<br/>When configured as output mode, register CCDAT1 is readable and writable.</li> </ul> |

### 12.4.15 Capture/compare register 2 (TIMx\_CCDAT2)

Offset address: 0x38

Reset value: 0x0000



| Bit field | Name         | Description   |
|-----------|--------------|---|
| 15:0      | CCDAT2[15:0] | <p>Capture/Compare 2 values</p> <ul style="list-style-type: none"> <li>CC2 channel is configured as output:<br/>CCDAT2 contains the value to be compared to the counter TIMx_CNT, signaling on the OC2 output.<br/>If the preload feature is not selected in TIMx_CCMOD1.OC2PEN bit, the written value is immediately transferred to the active register. Otherwise, this preloaded value is transferred to the active register only when an update event occurs.</li> <li>CC2 channel is configured as input:<br/>CCDAT2 contains the counter value transferred by the last input capture 2 event (IC2).<br/>When configured as input mode, register CCDAT2 is only readable.<br/>When configured as output mode, register CCDAT2 is readable and writable.</li> </ul> |

### 12.4.16 Capture/compare register 3 (TIMx\_CCDAT3)

Offset address: 0x3C

Reset value: 0x0000



| Bit field | Name         | Description  |
|-----------|--------------|--|
| 15:0      | CCDAT3[15:0] | <p>Capture/Compare 3 value</p> <ul style="list-style-type: none"> <li>CC3 channel is configured as output:<br/>CCDAT3 contains the value to be compared to the counter TIMx_CNT, signaling on the OC3 output.</li> <li>If the preload feature is not selected in TIMx_CCMOD2.OC3PEN bit, the written value is immediately transferred to the active register. Otherwise, this preloaded value is transferred to the active register only when an update event occurs.</li> <li>CC3 channel is configured as input:<br/>CCDAT3 contains the counter value transferred by the last input capture 3 event (IC3).</li> </ul> <p>When configured as input mode, register CCDAT3 is only readable.<br/>When configured as output mode, register CCDAT3 is readable and writable.</p> |

### 12.4.17 Capture/compare register 4 (TIMx\_CCDAT4)

Offset address: 0x40

Reset value: 0x0000

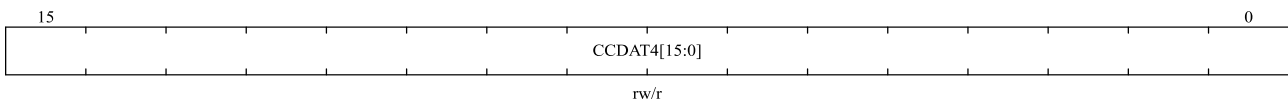

| Bit field | Name         | Description  |
|-----------|--------------|--|
| 15:0      | CCDAT4[15:0] | <p>Capture/Compare 4 value</p> <ul style="list-style-type: none"> <li>CC4 channel is configured as output:<br/>CCDAT4 contains the value to be compared to the counter TIMx_CNT, signaling on the OC4 output.</li> <li>If the preload feature is not selected in TIMx_CCMOD2.OC4PEN bit, the written value is immediately transferred to the active register. Otherwise, this preloaded value is transferred to the active register only when an update event occurs.</li> <li>CC4 channel is configured as input:<br/>CCDAT4 contains the counter value transferred by the last input capture 4 event (IC4).</li> </ul> <p>When configured as input mode, register CCDAT4 is only readable.<br/>When configured as output mode, register CCDAT4 is readable and writable.</p> |

### 12.4.18 DMA Control register (TIMx\_DCTRL)

Offset address: 0x48

Reset value: 0x0000

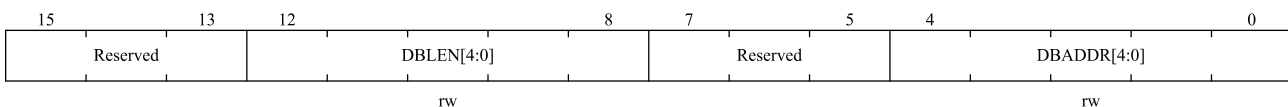

| Bit field | Name     | Description                                  |
|-----------|----------|--|
| 15:13     | Reserved | Reserved, the reset value must be maintained |

| Bit field | Name        | Description  |
|-----------|-------------|--|
| 12:8      | DBLEN[4:0]  | DMA Burst Length<br>This bit field defines the number DMA will accesses (write/read) TIMx_DADDR register.<br>00000: 1 time transfer<br>00001: 2 times transfers<br>00010: 3 times transfers<br>...<br>10001: 18 times transfers  |
| 7:5       | Reserved    | Reserved, the reset value must be maintained.  |
| 4:0       | DBADDR[4:0] | DMA Base Address<br>This bit field defines the first address where the DMA accesses the TIMx_DADDR register.<br>When access is done through the TIMx_DADDR first time, this bit-field specifies the address you just access. And then the second access to the TIMx_DADDR, you will access the address of "DMA Base Address + 4"<br><br>00000: TIMx_CTRL1,<br>00001: TIMx_CTRL2,<br>00010: TIMx_SMCTRL,<br>...<br>01011: TIMx_AR,<br>01100: Reserved,<br>01101: TIMx_CCDAT1,<br>.....<br>10000: TIMx_CCDAT4<br>10010: TIMx_DCTRL |

### 12.4.19 DMA transfer buffer register (TIMx\_DADDR)

Offset address: 0x4C

Reset value: 0x0000

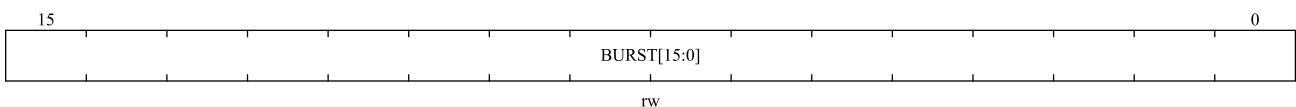

| Bit field | Name        | Description   |
|-----------|-------------|---|
| 15:0      | BURST[15:0] | DMA access buffer.<br>When a read or write operation is assigned to this register, the register located at the address range (DMA base address + DMA burst length × 4) will be accessed.<br>DMA base address = The address of TIM_CTRL1 + TIMx_DCTRL.DBADDR * 4;<br>DMA burst len = TIMx_DCTRL.DBLEN + 1. |

| Bit field | Name | Description   |
|-----------|------|---|
|           |      | <p>Example:</p> <p>If TIMx_DCTRL.DBLEN = 0x3(4 transfers), TIMx_DCTRL.DBADDR = 0xD (TIMx_CC DAT1), DMA data length = half word, DMA memory address = buffer address in SRAM, DMA peripheral address = TIMx_DADDR address.</p> <p>When an event occurs, TIMx will send requests to the DMA, and transfer data 4 times.</p> <p>For the first time, DMA access to the TIMx_ DADDR register will be mapped to access TIMx_CC DAT1 register;</p> <p>For the second time, DMA access to the TIMx_ DADDR register will be mapped to access TIMx_CC DAT2 register;</p> <p>... ..</p> <p>For the fourth time, DMA access to the TIMx_ DADDR register will be mapped to access TIMx_CC DAT4 register;</p> |

## 13 Basic timers (TIM6 and TIM7)

### 13.1 Introduction

Basic timers TIM6 and TIM7 each contain a 16-bit auto-reload counter.

These two timers are independent of each other and do not share any resources.

The basic timer can provide a time reference for general purpose timers.

The basic timer is directly connected to the DAC inside the chip and drives the DAC directly through the trigger output.

### 13.2 Main features

- 16-bit auto-reload up-counting counters.
- 16-bit programmable prescaler. (The frequency division factor can be configured with any value between 1 and 65536)
- Synchronization circuit for triggering DAC
- The events that generate the interrupt/DMA are as follows:
  - ◆ Update event

Figure 13-1 Block diagram of TIMx (x = 6 and 7)

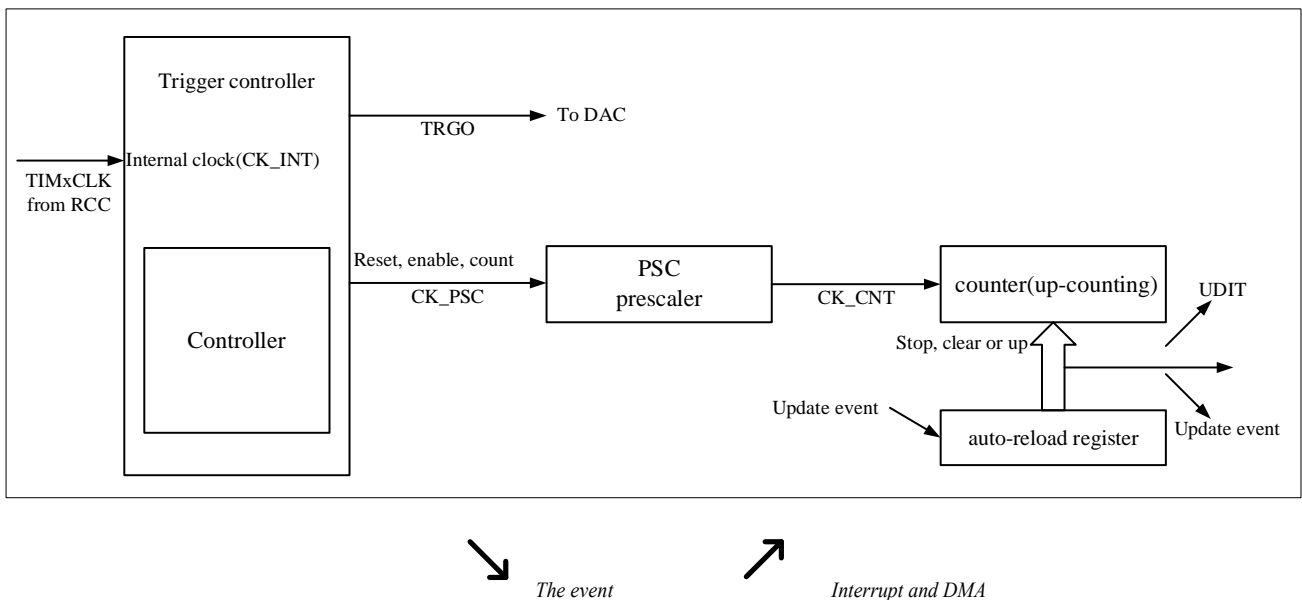

### 13.3 Basic timers description

#### 13.3.1 Time-base unit

The time-base unit mainly includes: prescaler, counter and auto-reload. When the time base unit is working, the software can read and write the corresponding registers (TIMx\_PSC, TIMx\_CNT and TIMx\_AR) at any time.

Depending on the setting of the auto-reload preload enable bit (TIMx\_CTRL1.ARPEN), the value of the preload register is transferred to the shadow register immediately or at each update event UEV. An update event is generated when the counter reaches the overflow condition and it can be generated by software when TIMx\_CTRL1.UPDIS=0. The counter CK\_CNT is valid only when the TIMx\_CTRL1.CNTEN bit is set. The counter starts counting one clock cycle after the TIMx\_CTRL1.CNTEN bit is set.

### 13.3.1.1 Prescaler description

The TIMx\_PSC register consists of a 16-bit counter that can be used to divide the counter clock frequency by any factor between 1 and 65536. It can be changed on the fly as it is buffered. The prescaler value is only taken into account at the next update event.

Figure 13-2 Counter timing diagram with prescaler division change from 1 to 4

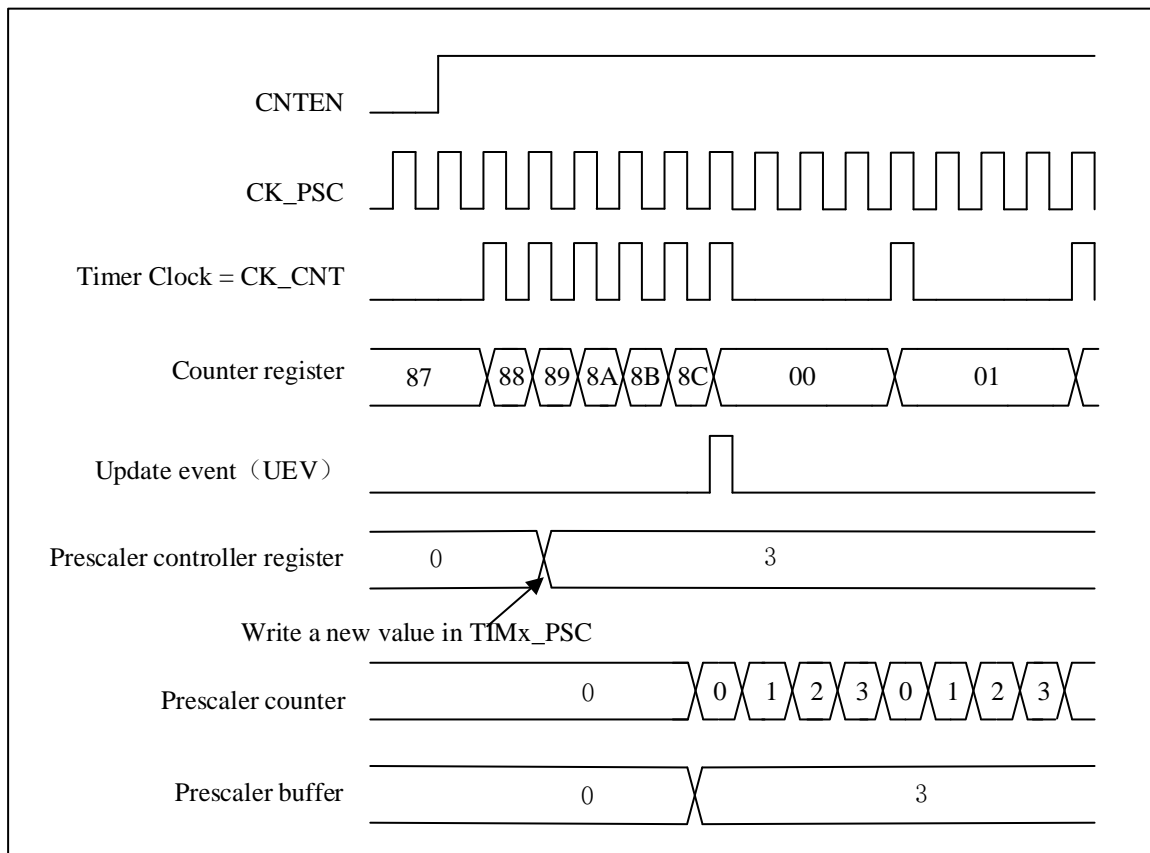

## 13.3.2 Counter mode

### 13.3.2.1 Up-counting mode

In up-counting mode, the counter will count from 0 to the value of the register TIMx\_AR, then it resets to 0. And a counter overflow event is generated.

If the TIMx\_CTRL1.UPRS bit (select update request) and the TIMx\_EVTGEN.UDGN bit are set, an update event (UEV) will generate, and TIMx\_STS.UDITF will not be set by hardware. Therefore, no update interrupts or update DMA requests are generated. This setting is used in scenarios where you want to clear the counter but do not want to generate an update interrupt.

Depending on the update request source is configured in TIMx\_CTRL1.UPRS, When an update event occurs,

TIMx\_STS.UDITF is set, all registers are updated:

- Update auto-reload shadow registers with preload value(TIMx\_AR), when TIMx\_CTRL1.ARPEN = 1.
- The prescaler shadow register is reloaded with the preload value(TIMx\_PSC)

To avoid updating the shadow registers when new values are written to the preload registers, you can disable the update by setting TIMx\_CTRL1.UPDIS=1.

When an update event occurs, the counter will still be cleared and the prescaler counter will also be set to 0 (but the prescaler value will remain unchanged).

The figure below shows some examples of the counter behavior and the update flags for different division factors in the up-counting mode.

Figure 13-3 Timing diagram of up-counting. The internal clock divider factor = 2/N

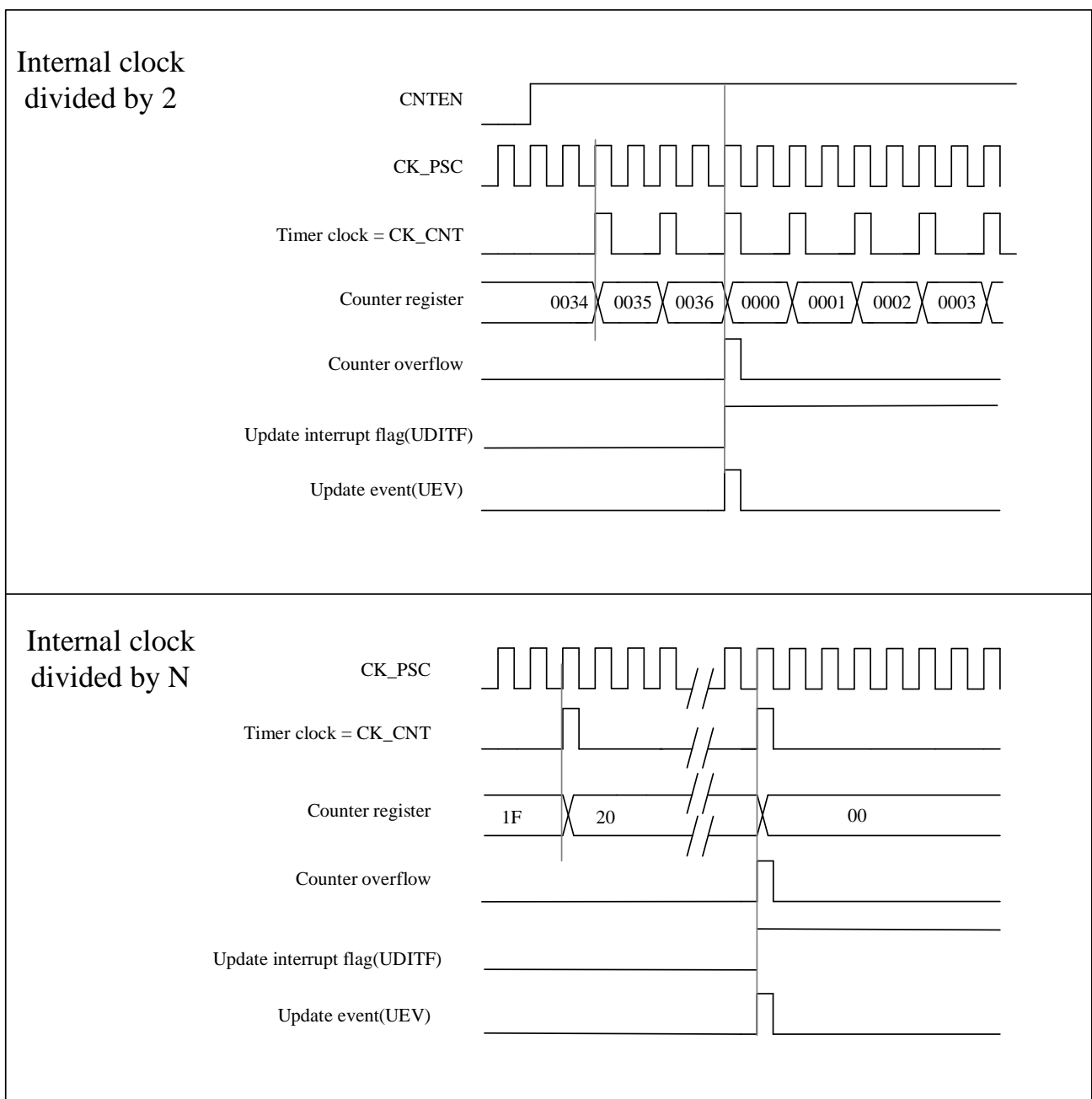
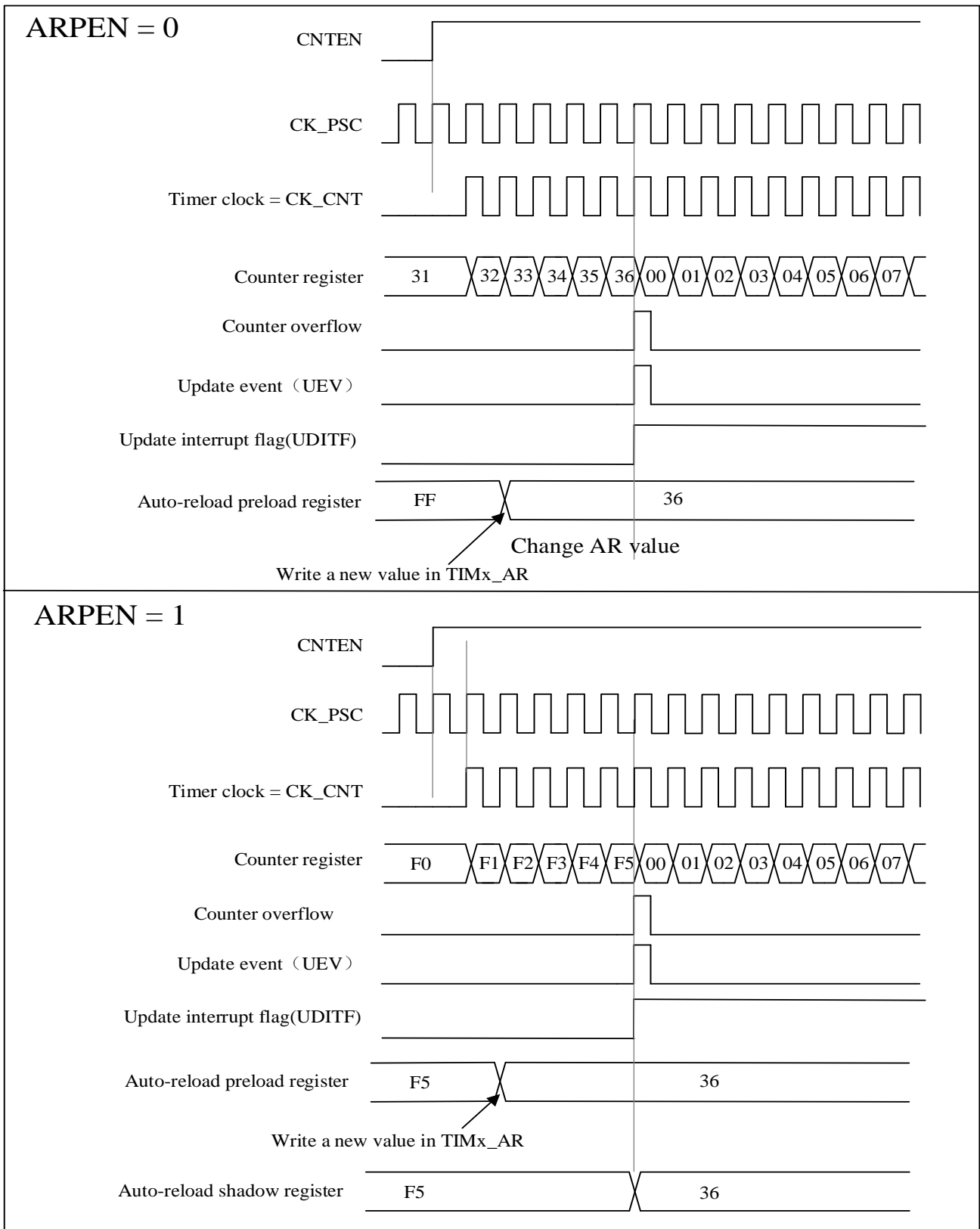

Figure 13-4 Timing diagram of the up-counting, update event when ARPEN=0/1



### 13.3.3 Clock selection

- The internal clock of timers : CK\_INT

#### 13.3.3.1 Internal clock source (CK\_INT)

It is provided that the TIMx\_CTRL1.CNTEN bit is written as ' 1 ' by software, the clock source of the prescaler is provided by the internal clock CK\_INT.

Figure 13-5 Control circuit in normal mode, internal clock divided by 1

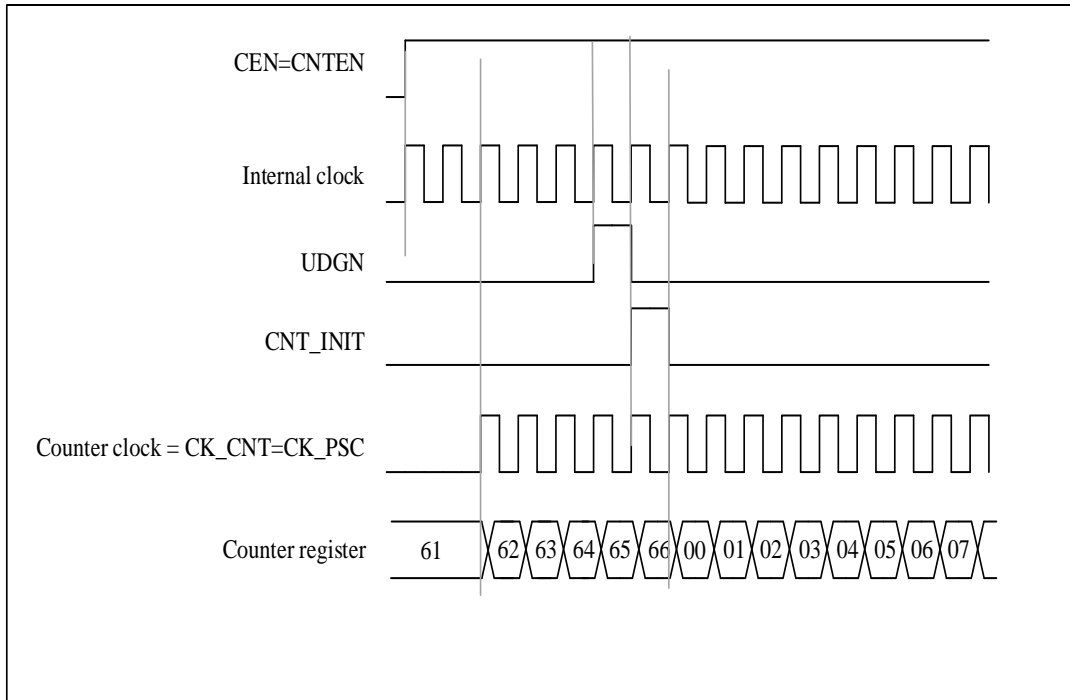

### 13.3.4 Debug mode

When the microcontroller is in debug mode (the Cortex-M4 core halted), depending on the DBG\_CTRL.TIMx\_STOP configuration in the DBG module, the TIMx counter can either continue to work normally or stop. For more details, see 29.4.3

## 13.4 TIMx register description(x = 6 and 7)

For abbreviations used in registers, see section 1.1.

These peripheral registers can be operated as half word (16-bits) or one word (32-bits).

### 13.4.1 Register overview

Table 13-1 Register overview

| Offset | Register    | 31       | 30 | 29 | 28 | 27 | 26 | 25 | 24 | 23 | 22 | 21 | 20 | 19 | 18 | 17         | 16       | 15 | 14       | 13    | 12   | 11    | 10    | 9 | 8 | 7 | 6 | 5 | 4 | 3 | 2 | 1 | 0 |   |   |   |
|--------|-------------|----------|----|----|----|----|----|----|----|----|----|----|----|----|----|------------|----------|----|----------|-------|------|-------|-------|---|---|---|---|---|---|---|---|---|---|---|---|---|
| 000h   | TIMx_CTRL1  | Reserved |    |    |    |    |    |    |    |    |    |    |    |    |    | ARPEN      | Reserved |    |          | ONEPM | UPRS | UPDIS | CNTEN |   |   |   |   |   |   |   |   |   |   |   |   |   |
|        | Reset Value |          |    |    |    |    |    |    |    |    |    |    |    |    |    | 0          |          |    |          | 0     | 0    | 0     | 0     |   |   |   |   |   |   |   |   |   |   |   |   |   |
| 004h   | TIMx_CTRL2  | Reserved |    |    |    |    |    |    |    |    |    |    |    |    |    | MMSEL[2:0] |          |    | Reserved |       |      |       |       |   |   |   |   |   |   |   |   |   |   |   |   |   |
|        | Reset Value |          |    |    |    |    |    |    |    |    |    |    |    |    |    | 0          | 0        | 0  |          |       |      |       |       |   |   |   |   |   |   |   |   |   |   |   |   |   |
| 008h   | Reserved    |          |    |    |    |    |    |    |    |    |    |    |    |    |    |            |          |    |          |       |      |       |       |   |   |   |   |   |   |   |   |   |   |   |   |   |
| 00Ch   | TIMx_DINTEN | Reserved |    |    |    |    |    |    |    |    |    |    |    |    |    | UDEN       | Reserved |    |          | UIEN  |      |       |       |   |   |   |   |   |   |   |   |   |   |   |   |   |
|        | Reset Value |          |    |    |    |    |    |    |    |    |    |    |    |    |    | 0          |          |    |          | 0     |      |       |       |   |   |   |   |   |   |   |   |   |   |   |   |   |
| 010h   | TIMx_STS    | Reserved |    |    |    |    |    |    |    |    |    |    |    |    |    |            |          |    | UDITF    |       |      |       |       |   |   |   |   |   |   |   |   |   |   |   |   |   |
|        | Reset Value |          |    |    |    |    |    |    |    |    |    |    |    |    |    |            |          |    | 0        |       |      |       |       |   |   |   |   |   |   |   |   |   |   |   |   |   |
| 014h   | TIMx_EVTGEN | Reserved |    |    |    |    |    |    |    |    |    |    |    |    |    |            |          |    | UDGN     |       |      |       |       |   |   |   |   |   |   |   |   |   |   |   |   |   |
|        | Reset Value |          |    |    |    |    |    |    |    |    |    |    |    |    |    |            |          |    | 0        |       |      |       |       |   |   |   |   |   |   |   |   |   |   |   |   |   |
| 018h   | Reserved    |          |    |    |    |    |    |    |    |    |    |    |    |    |    |            |          |    |          |       |      |       |       |   |   |   |   |   |   |   |   |   |   |   |   |   |
| 01Ch   | Reserved    |          |    |    |    |    |    |    |    |    |    |    |    |    |    |            |          |    |          |       |      |       |       |   |   |   |   |   |   |   |   |   |   |   |   |   |
| 020h   | Reserved    |          |    |    |    |    |    |    |    |    |    |    |    |    |    |            |          |    |          |       |      |       |       |   |   |   |   |   |   |   |   |   |   |   |   |   |
| 024h   | TIMx_CNT    | Reserved |    |    |    |    |    |    |    |    |    |    |    |    |    | CNT[15:0]  |          |    |          |       |      |       |       |   |   |   |   |   |   |   |   |   |   |   |   |   |
|        | Reset Value |          |    |    |    |    |    |    |    |    |    |    |    |    |    | 0          | 0        | 0  | 0        | 0     | 0    | 0     | 0     | 0 | 0 | 0 | 0 | 0 | 0 | 0 | 0 | 0 | 0 | 0 | 0 | 0 |
| 028h   | TIMx_PSC    | Reserved |    |    |    |    |    |    |    |    |    |    |    |    |    | PSC[15:0]  |          |    |          |       |      |       |       |   |   |   |   |   |   |   |   |   |   |   |   |   |
|        | Reset Value |          |    |    |    |    |    |    |    |    |    |    |    |    |    | 0          | 0        | 0  | 0        | 0     | 0    | 0     | 0     | 0 | 0 | 0 | 0 | 0 | 0 | 0 | 0 | 0 | 0 | 0 | 0 | 0 |
| 02Ch   | TIMx_AR     | Reserved |    |    |    |    |    |    |    |    |    |    |    |    |    | AR[15:0]   |          |    |          |       |      |       |       |   |   |   |   |   |   |   |   |   |   |   |   |   |
|        | Reset Value |          |    |    |    |    |    |    |    |    |    |    |    |    |    | 1          | 1        | 1  | 1        | 1     | 1    | 1     | 1     | 1 | 1 | 1 | 1 | 1 | 1 | 1 | 1 | 1 | 1 | 1 | 1 | 1 |

### 13.4.2 Control Register 1 (TIMx\_CTRL1)

Offset address: 0x00

Reset value: 0x0000

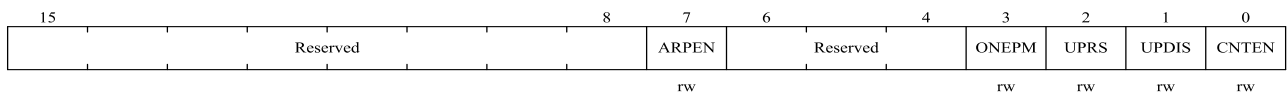

| Bit field | Name     | Description                                  |
|-----------|----------|--|
| 15:8      | Reserved | Reserved, the reset value must be maintained |

| Bit field | Name     | Description  |
|-----------|----------|--|
| 7         | ARPEN    | ARPEN: Auto-reload preload enable<br><br>0: Shadow register disable for TIMx_AR register<br><br>1: Shadow register enable for TIMx_AR register   |
| 6:4       | Reserved | Reserved, the reset value must be maintained   |
| 3         | ONEPM    | One-pulse mode<br><br>0: Disable one-pulse mode, the counter counts are not affected when an update event occurs.<br><br>1: Enable one-pulse mode, the counter stops counting when the next update event occurs (clearing TIMx_CTRL1.CNTEN bit)  |
| 2         | UPRS     | Update request source<br><br>This bit is used to select the UEV event sources by software.<br><br>0: If update interrupt or DMA request is enabled, any of the following events will generate an update interrupt or DMA request: <ul style="list-style-type: none"> <li>– Counter overflow</li> <li>– The TIMx_EVTGEN.UDGN bit is set</li> </ul> 1: If update interrupt or DMA request is enabled, only counter overflow will generate update interrupt or DMA request  |
| 1         | UPDIS    | Update disable<br><br>This bit is used to enable/disable the Update event (UEV) events generation by software.<br><br>0: Enable UEV. UEV will be generated if one of following condition been fulfilled: <ul style="list-style-type: none"> <li>– Counter overflow</li> <li>– The TIMx_EVTGEN.UDGN bit is set</li> </ul> Shadow registers will update with preload value.<br><br>1: UEV disabled. No update event is generated, and the shadow registers (AR, PSC) keep their values. If the TIMx_EVTGEN.UDGN bit is set, the counter and prescaler are reinitialized. |
| 0         | CNTEN    | Counter Enable<br><br>0: Disable counter<br><br>1: Enable counter  |

### 13.4.3 Control Register 2 (TIMx\_CTRL2)

Offset address: 0x04

Reset value: 0x0000

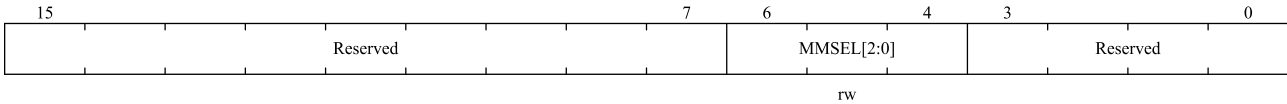

| Bit field | Name       | Description  |
|-----------|------------|--|
| 15:7      | Reserved   | Reserved, the reset value must be maintained   |
| 6:4       | MMSEL[2:0] | <p>Master Mode Selection</p> <p>These 3 bits (TIMx_CTRL2.MMSEL [2:0]) are used to select the synchronization information (TRGO) sent to the slave timer in the master mode. Possible combinations are as follows:</p> <p>000: Reset –When the TIMx_EVTGEN.UDGN is set or a reset is generated by the slave mode controller, a TRGO pulse occurs. And in the latter case, the signal on TRGO is delayed compared to the actual reset.</p> <p>001: Enable - The TIMx_CTRL1.CNTEN bit is used as the trigger output (TRGO). Sometimes you need to start multiple timers at the same time or enable slave timer for a period of time. The counter enable signal is set when TIMx_CTRL1.CNTEN bit is set or the trigger input in gated mode is high.</p> <p>010: Update - The update event is selected as the trigger output (TRGO). For example, a master timer clock can be used as a slave timer prescaler.</p> <p>011: Compare pulse - Triggers the output to send a positive pulse (TRGO) when the TIMx_STS.CC1ITF is to be set (even if it is already high), when a capture or a comparison succeeds.</p> |
| 15: 1     | Reserved   | Reserved, the reset value must be maintained.  |

### 13.4.4 DMA/Interrupt Enable Registers (TIMx\_DINTEN)

Offset address: 0x0C

Reset value: 0x0000

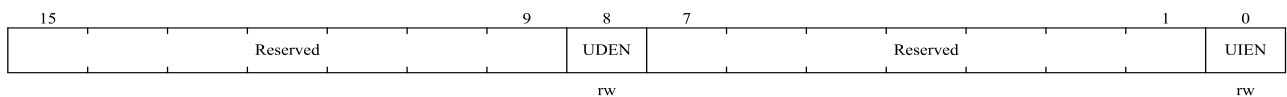

| Bit field | Name     | Description   |
|-----------|----------|---|
| 15:9      | Reserved | Reserved, the reset value must be maintained  |
| 8         | UDEN     | <p>Update DMA Request enable</p> <p>0: Disable update DMA request</p> <p>1: Enable update DMA request</p> |
| 7:1       | Reserved | Reserved, the reset value must be maintained  |

| Bit field | Name | Description  |
|-----------|------|--|
| 0         | UIEN | Update interrupt enable<br><br>0: Disable update interrupt<br><br>1: Enable update interrupt |

### 13.4.5 Status Registers (TIMx\_STS)

Offset address: 0x10

Reset value: 0x0000

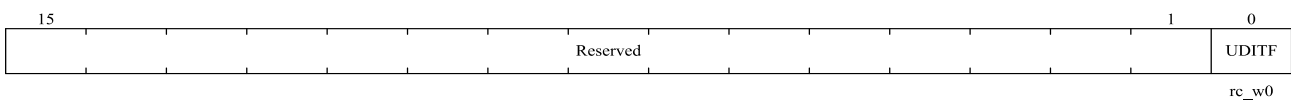

| Bit field | Name     | Description   |
|-----------|----------|---|
| 15:1      | Reserved | Reserved, the reset value must be maintained  |
| 0         | UDITF    | Update interrupt flag<br><br>This bit is set by hardware when an update event occurs under the following conditions:<br><ul style="list-style-type: none"> <li>— When TIMx_CTRL1.UPDIS = 0, and counter value overflow.</li> <li>— When TIMx_CTRL1.UPRS = 0, TIMx_CTRL1.UPDIS = 0, and set the TIMx_EVTGEN.UDGN bit by software to reinitialize the CNT.</li> </ul> This bit is cleared by software.<br><br>0: No update event occurred<br><br>1: Update interrupt occurred |

### 13.4.6 Event Generation registers (TIMx\_EVTGEN)

Offset address: 0x14

Reset values: 0 x0000

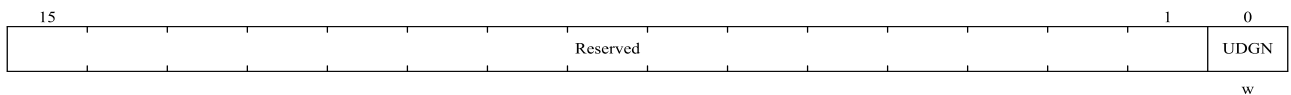

| Bit field | Name     | Description                                   |
|-----------|----------|---|
| 15: 1     | Reserved | Reserved, the reset value must be maintained. |
| 0         | UDGN     | UDGN: Update generation                       |

| Bit field | Name | Description   |
|-----------|------|---|
|           |      | Software can set this bit to update configuration register value and hardware will clear it automatically.<br><br>0: No effect.<br><br>1: Timer counter will restart and all shadow register will be updated. It will restart prescaler counter also. |

### 13.4.7 Counter (TIMx\_CNT)

Offset address: 0x24

Reset value: 0x0000

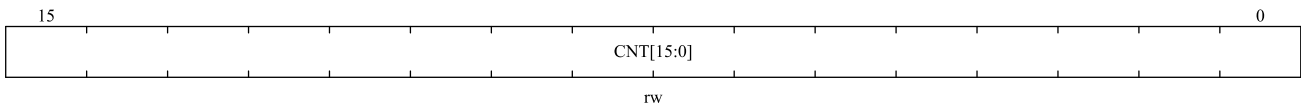

| Bit field | Name      | Description   |
|-----------|-----------|---------------|
| 15:0      | CNT[15:0] | Counter value |

### 13.4.8 Prescaler (TIMx\_PSC)

Offset address: 0x28

Reset value: 0x0000

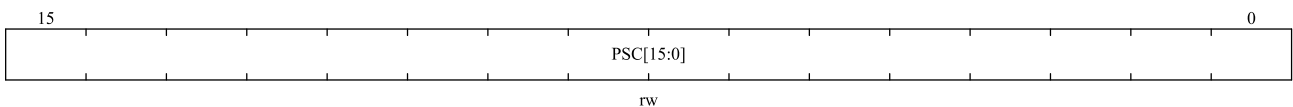

| Bit field | Name      | Description   |
|-----------|-----------|---|
| 15:0      | PSC[15:0] | Prescaler value<br><br>PSC register value will be updated to prescaler register at update event. Counter clock frequency is input clock frequency divide PSC + 1. |

### 13.4.9 Automatic reload register (TIMx\_AR)

Offset address: 0x2C

Reset values: 0xFFFF

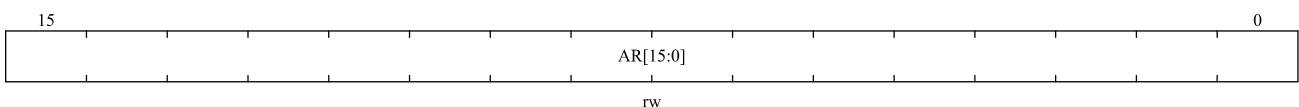

| <b>Bit field</b> | <b>Name</b> | <b>Description</b>  |
|------------------|-------------|---|
| 15:0             | AR[15:0]    | <p>Auto-reload value</p> <p>These bits define the value that will be loaded into the actual auto-reload register.</p> <p>See 13.3.1 for more details.</p> <p>When the TIMx_AR.AR [15:0] value is null, the counter does not work.</p> |

## 14 Real-time clock (RTC)

### 14.1 Description

- The real-time clock (RTC) is an independent BCD timer/counter.
- Daylight saving time compensation supported by software.
- A periodic automatic programmable wakeup timer.
- Two 32-bit registers contain the seconds, minutes, hours, day (day of week), date (day of month), month, and year.
- Independent 32-bit register contain sub-seconds value.
- Two programmable alarms.
- Two 32-bit registers contain two programmable alarms seconds, minutes, hours, day (day of week), and date (day of month).
- Two 32-bit registers contain two programmable alarms sub-seconds.
- Digital calibration function.
- Time-Stamp function.
- After Backup domain reset, all RTC registers are protected against possible parasitic write accesses.
- Multiple Wakeup sources of Interrupt/Event. These include Alarm A, Alarm B, Wakeup Timer, Time-Stamp.
- After RTC is enabled by the RCC register and voltage remains in the operating range, RTC will not stop timing in any mode (include RUN mode, SLEEP mode, STOP0 mode, STOP2 mode and STANDBY mode).
- RTC provides a variety of ways to wakeup from all low-power modes (SLEEP mode, STOP0 mode, STOP2 mode and STANDBY mode).

#### 14.1.1 Specification

Table 14-1 RTC feature support

| Main function | Description   |
|---------------|---|
| Clock         | RTC clock can be selected from LSI, LSE and HSE, which are 40KHz, 32.768KHz and HSE / 128 respectively  |
| Reset         | The APB interface is reset by the system. Some register reset from RTC module is synchronized with APB reset.<br>RTC core is reset by backup domain reset.                                |
| Calendar      | Calendar consists of sub second, second, minute, hour (12 or 24 format), day (day of the week), date, month and year. These data are stored in the shadow register of APB module.         |
| Wakeup Timer  | Output "RTC_OUT" can be configured to send wakeup events to GPIO. At the same time, it also can be configured as an interrupt/event to wake up the system from SLEEP, STOP0 ,STOP2 modes. |

| Main function     | Description  |
|-------------------|--|
| Alarm             | Programmable alarm clock and interrupt function. The alarm can be triggered by any combination of the calendar fields. When the alarm event occurs the alarm flag can be sent to GPIO through “RTC_OUT”, and it also can be used to wake up the CPU or exit from the low power status such as SLEEP, STOP0, STOP2 and STANDBY modes. |
| Timestamp         | Time-stamp function for GPIO event saving.   |
| Interrupts/events | Alarm A/Alarm B interrupt/event<br>Wakeup interrupt/event<br>Timestamp interrupt/event   |

## 14.2 RTC function description

### 14.2.1 RTC block diagram

Figure 14-1 RTC Block Diagram

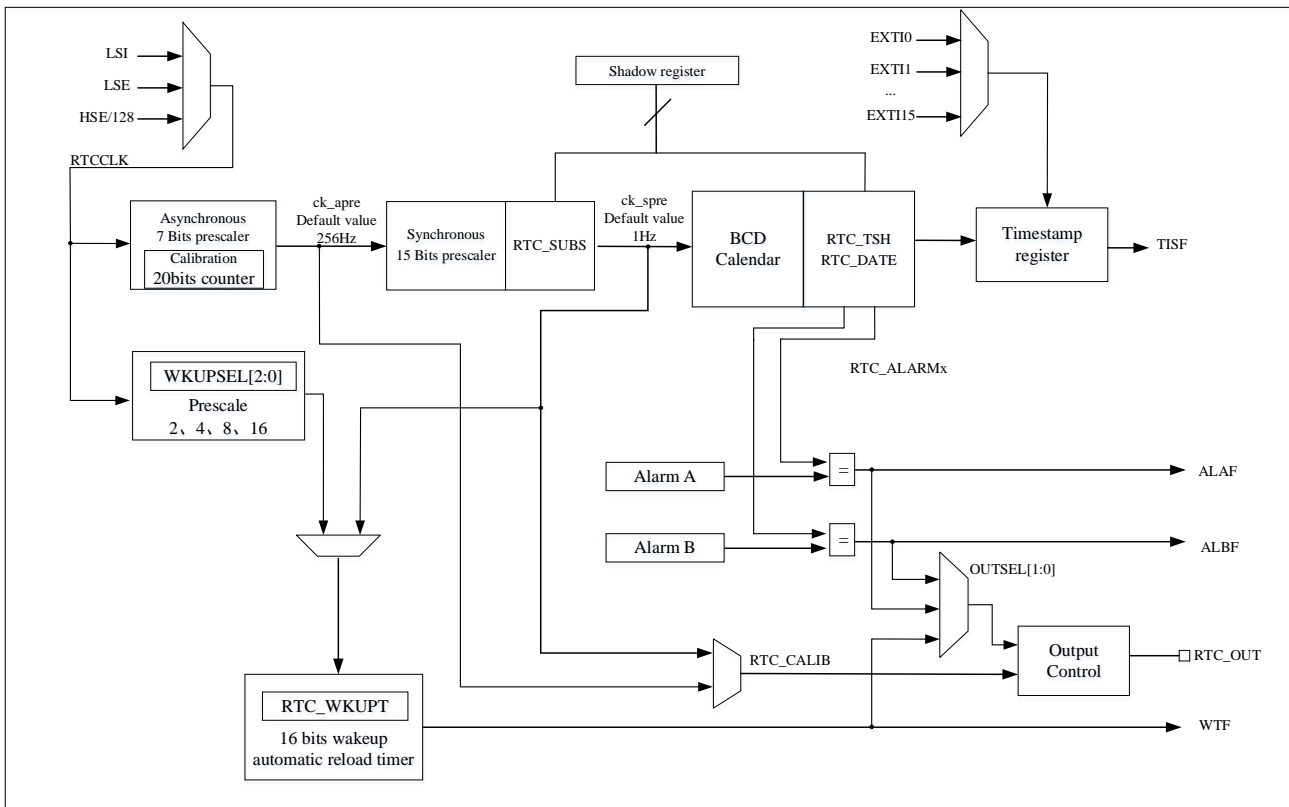

RTC includes the following functions:

- Alarm A and Alarm B event/interrupt
- Timestamp event/interrupt
- RTC output functions
  - ◆ 256 Hz or 1Hz clock output (LSE frequency is 32.768 kHz).
  - ◆ Alarm clock output (polarity configurable), Alarm A and Alarm B are optional.

- ◆ Auto wakeup output (polarity configurable).
- RTC input functions:
  - ◆ Timestamp event detection
- Control PC13 by configuring output register:
  - ◆ Set RTC\_OPT.TYPE bit to configure open-drain/push-pull output of PC13

### 14.2.2 GPIOs of RTC

Timestamp input come from IOM (mapped to PC13) or EXTI module, if EXTI module is needed to start, please refer to the timestamp trigger source selection register (EXTI\_TS\_SEL) for details.

RTC\_OUT (Alarm, Wakeup event or calibration output (256Hz or 1Hz)) is mapped to PC13. Regardless of the PC13 GPIO configuration, the PC13 pin configuration is controlled by the RTC as an output.

### 14.2.3 RTC register write protection

PWR\_CTRL.DBKP bit (see the Power Control section) is cleared in default, so the PWR\_CTRL.DBKP bit must set to “1” to enable write access to the RTC register. Once the backup domain is reset, all write protection RTC registers are write protected. All write protection RTC registers require the following steps to unlock write protection:

- Write “0xCA” into RTC\_WRP register.
- Write “0x53” into RTC\_WRP register.

The unlocking mechanism only checks the write operation to the RTC\_WRP register. During or before and after the unlocking process, the write operation to other registers does not affect the unlocking result.

### 14.2.4 RTC clock and prescaler

RTC clock source:

- LSE clock
- LSI clock
- HSE/128 clock

For the purpose of reduction of power consumption, the prescaler is divided into 2 programmable prescalers, they are asynchronous prescaler and synchronous prescaler. If both prescaler are used, it is recommended that the value of the asynchronous divider be as large as possible.

- A 7-bit asynchronous prescaler which is given by RTC\_PRE.DIVA[6:0] bits
- A 15-bit synchronous prescaler which is given by RTC\_PRE.DIVS[14:0] bits

The formula for  $f_{ck\_apre}$  and  $f_{ck\_spre}$  are given below:

$$f_{ck\_apre} = \frac{f_{RTCCLK}}{RTC\_PRE.DIVA[6:0]+1}$$

$$f_{ck\_spre} = \frac{f_{RTCCLK}}{(RTC\_PRE.DIVS[14:0]+1)*(RTC\_PRE.DIVA[6:0]+1)}$$

The `ck_apre` clock is used to driven `RTC_SUBS` sub-second down counter. When it reaches 0, reload `RTC_SUBS` with the value of `RTC_PRE.DIVS[14:0]`.

## 14.2.5 RTC calendar

There are three shadow registers, they are `RTC_DATE`, `RTC_TSH` and `RTC_SUBS`. The RTC time and date registers can be accessed through the shadow registers. It is also possible to access them directly to avoid the synchronization waiting time. The three shadow registers are as follow:

- `RTC_DATE`: set and read date
- `RTC_TSH`: set and read time
- `RTC_SUBS`: read sub-second

After every two `RTCCLK` cycles, the current calendar value is copied to the shadow register, and `RTC_INITSTS.RSYF` bit is set to 1. This process is not performed in low power (stop & standby) modes. While exiting these modes, the shadow register updates the values after 2 `RTCCLK` cycles.

By default, when user try to access the calendar register, it accesses the contents of the shadow register instead. User can access the calendar register directly by setting the `RTC_CTRL.BYPS` bit.

When `RTC_CTRL.BYPS=0`, calendar values are from shadow registers, when reading `RTC_SUBS`, `RTC_TSH` or `RTC_DATE` register, it is necessary to make ensure the frequency of APB1 clock ( $f_{APB1}$ ) is at least 7 times the frequency of RTC clock ( $f_{RTCCLK}$ ), and APB1 clock frequency lower than RTC clock frequency is not allowed in any case. System reset will reset shadow registers.

## 14.2.6 Calendar initialization and configuration

The value of prescaler and calendar can be initialized by the following steps:

- Enter initialization mode by setting “1” to `RTC_INITSTS.INITM` bit, then wait for `RTC_INITSTS.INITF` flag to be set 1.
- Set `RTC_PRE.DIVS[14:0]` and `RTC_PRE.DIVA[6:0]` value.
- Write the initial calendar values include time and date into the shadow registers (`RTC_TSH` and `RTC_DATE`) and configure the time format (12 or 24 hours) by the `RTC_CTRL.HFMT` bit.
- Exit initialization mode by clearing the `RTC_INITSTS.INITM` bit.

The values of calendar counter will automatically loaded from shadow registers after 4 `RTCCLK` clock cycles, then the calendar counter restarts.

Note: Before entering the RTC initialization mode, ensure that the value of `RTC_SUBS.SS[15:0]` is not less than 2, and not equal to `RTC_PRE.DIVS[14:0]`, and read `RTC_DATE` register once.

## 14.2.7 Calendar reading

### 1. Reading calendar value when `RTC_CTRL.BYPS=0`

Calendar value is read from shadow registers if `RTC_CTRL.BYPS=0`. In order to read RTC calendar registers (`RTC_SUBS`, `RTC_TSH` and `RTC_DATE`) correctly, APB1 clock frequency must be set equal to or greater than 7

times of RTC clock frequency. In any case, APB1 clock frequency must not be less than RTC clock frequency.

If APB1 clock frequency is not equal to or greater than 7 times of RTC clock frequency, refer to the following process to read calendar value.

- Read the data of RTC\_SUBS, RTC\_TSH and RTC\_DATE twice.
- Compare the data read twice, if they are equal, the read data can be considered correct; if they are not equal, read the data for the third time.
- The third time read data can be considered correct.

Shadow registers (RTC\_SUBS, RTC\_TSH and RTC\_DATE) are updated every two RTCCLK cycles. If user want to read calendar value in a short time (less than two RTCCLK cycles), RTC\_INITSTS.RSYF bit must be cleared by software after the first time read.

In some cases, it is necessary to wait until RTC\_INITSTS.RSYF bit is set 1 before read calendar value.

- After waking up from the low power modes (STOP mode, STANDBY mode), clear RTC\_INITSTS.RSYF bit, then wait RTC\_INITSTS.RSYF bit is set again.
- System reset.
- Calendar complete initialization.
- Calendar complete synchronization.

## 2. Reading calendar value when RTC\_CTRL.BYPS=1

Reading the calendar value directly from the calendar counter if RTC\_CTRL.BYPS=1. The advantage of this configuration is that read calendar value without delay after wakeup from the low power mode, the disadvantage is that these data of RTC\_SUBS, RTC\_TSH and RTC\_DATE may not be at a time.

To ensure the correctness of read calendar value, it is necessary to read RTC\_SUBS, RTC\_TSH and RTC\_DATE twice, then compare the data read twice, if they are equal, the read data can be considered correct;

Note: After read RTC\_SUBS or RTC\_TSH register, it needs to read RTC\_DATE register once.

## 14.2.8 Calibration clock output

When RTC\_CTRL.COEN set to 1, PC13 pin will output calibration clock. If RTC\_CTRL.CALOSEL=0 and RTC\_PRE.DIVA[6:0] = 0x7F, the RTC\_CALIB frequency results is  $f_{RTCCLK}/RTC\_PRE.DIVA[6:0]$ . This is equivalent to a calibration output of 256 Hz when the RTCCLK frequency is 32.768 kHz. The rising edge is recommended for there is slight jitter on the falling edge.

When RTC\_CTRL.CALOSEL=1 and "RTC\_PRE.DIVS[14:0]+1" is a non-zero integer multiple of 256, the RTC\_CALIB frequency is given by the formula  $f_{RTCCLK}/(256 * (DIVA+1))$ . This is equivalent to 1Hz calibration output when the RTCCLK frequency is 32.768 kHz and RTC\_PRE.DIVA[6:0] = 0x7F.

*Note: When the RTC\_CALIB or RTC\_ALARM output is selected, the RTC\_OUT pin (PC13) is automatically configured as output.*

## 14.2.9 Programmable alarms

RTC has 2 programmable alarms: Alarm A and Alarm B.

RTC alarm can be enabled or disabled by RTC\_CTRL.ALxEN bit. If the alarm value match the calendar values, the RTC\_INITSTS.ALxF flag will be set 1. Each calendar field can be selected to trigger alarm interrupt if RTC\_CTRL.ALxIEN bit is enabled.

Alarm output: Alarm A or Alarm B can be mapped to RTC\_ALxRM output when RTC\_CTRL.OUTSEL[1:0] is selected, and output polarity can be configured by RTC\_CTRL.OPOL bit.

Note: If the seconds field is selected (RTC\_ALARMx.MASK1 bit reset), RTC\_PRE.DIVS[14:0] must be larger than 3 to ensure correct operation.

## 14.2.10 Alarm configuration

Alarm A and Alarm B should be configured in the following below:

- Disable Alarm A/Alarm B by clearing RTC\_CTRL.ALAEN/RTC\_CTRL.ALBEN bit.
- Configure the Alarm x registers (RTC\_ALRMxSS/RTC\_ALARMx)
- Enable Alarm A/Alarm B interrupt by set RTC\_CTRL.ALAIEN/RTC\_CTRL.ALBIEN bit(this step can be selected as needed )
- Enable Alarm A/Alarm B by setting RTC\_CTRL.ALAEN/RTC\_CTRL.ALBEN bit.

## 14.2.11 Alarm output

When RTC\_CTRL.OUTSEL[1:0] !=0, RTC\_ALARM alternate function output is enable. There are Alarm A output, Alarm B output and Wakeup output to choose by the value of RTC\_CTRL.OUTSEL[1:0] bits.

RTC\_CTRL.OPOL bit control the polarity of the Alarm A, Alarm B or Wakeup output.

RTC\_OPT.TYPE bit control the RTC\_ALARM pin to output open drain or output pull-up.

When RTC\_CALIB or RTC\_ALARM output is selected, the RTC\_OUT pin (PC13) is automatically configured as output.

## 14.2.12 Periodic automatic wakeup

A 16-bit programmable auto-load down counter can generate periodic wakeup flag if reaches 0. It is also can be extend the range of wakeup timer to 17 bits. Periodic automatic wakeup can be enabled by setting RTC\_CTRL.WTEN.

There are two wake-up input clock sources can be selected:

- RTC clock (RTCCLK) divided by 2/ 4/8/16.
  - Assume RTCCLK comes from LSE (32.768KHz), wake-up interrupt period can be configured range from 122us to 32s under the resolution down to 61us.
- Internal clock ck\_spre.
  - ◆ Assume ck\_spre frequency is 1Hz, the available wake-up time range from 2s to 18h, and the resolution is 1 second.
  - ◆ When RTC\_CTRL.WKUPSEL [2:0] = 10x, the period is range from 2s to 18h.

After RTC\_CTRL.WTEN bit is set to 1, the down counter is running and when it reaches 0, RTC\_INITSTS.WTF

will be set and the device can exit from low power mode(except Standby mode) when the periodic wakeup interrupt is enabled by setting the RTC\_CTRL.WTIEN bit.

Periodic wakeup output: periodic wakeup can be mapped to RTC\_ALxRM output when RTC\_CTRL.OUTSEL[1:0] is selected, the RTC\_OUT pin(PC13) is automatically configured as output, and output polarity can be configured by RTC\_CTRL.OPOL bit.

### 14.2.13 Wakeup timer configuration

The wakeup timer automatic reload value should be configured in the following below:

- Disable wakeup timer by clearing RTC\_CTRL.WTEN bit, then wait for RTC\_INITSTS.WTWF flag to be set 1.
- Select wake up timer clock by set RTC\_CTRL.WKUPSEL[2:0] bits.
- Configure the wake-up automatic reload value by set RTC\_WKUPT.WKUPT[15:0] bits.
- Enable Wakeup interrupt by set RTC\_CTRL.WTIEN bit(this step can be selected as needed )
- Enable wakeup timer by setting RTC\_CTRL.WTEN bit

### 14.2.14 Timestamp function

Timestamp can be enabled by setting RTC\_CTRL.TSEN bit to 1. When a timestamp event is detected on the RTC\_TS pin, the calendar values of the event will be stored in the timestamp register (RTC\_TSSS, RTC\_TST, RTC\_TSD), and RTC\_INITSTS.TISF is set to 1. If a new timestamp event is detected when RTC\_INITSTS.TISF has been set to 1 already, the hardware sets RTC\_INITSTS.TISOVF flag to 1, and the timestamp registers (RTC\_TST and RTC\_TSD) will continue to hold the value of the previous event, which means timestamp registers(RTC\_TST and RTC\_TSD) data will not change when RTC\_INITSTS.TISF=1.

After the timestamp event caused by the synchronization process occurs again, RTC\_INITSTS.TISF is set to 1 in 2 RTC\_CLK cycles. There is no delay in the generation of RTC\_INITSTS.TISOVF. This means that if two timestamp events are very close, this can cause RTC\_INITSTS.TISOVF to be "1" and RTC\_INITSTS.TISF to be "0". Therefore, after detecting that RTC\_INITSTS.TISF is "1", then detect RTC\_INITSTS.TISOVF bit.

If timestamp events are enabled, the timestamp will capture the calendar read in the timestamp register. Timestamp events can be generated on any of the 16 GPIO ports selected by EXTI. The GPIO pins in each port are selected by setting the corresponding EXTI\_TS\_SEL.TSSEL[3:0] bits.

### 14.2.15 Daylight saving time configuration

Daylight saving time function can be controlled by RTC\_CTRL.SU1H, RTC\_CTRL.AD1H, and RTC\_CTRL.BAKP bits. Calendar will subtract one hour when set RTC\_CTRL.SU1H bit to 1, and add one hour when set RTC\_CTRL.AD1H to 1. RTC\_CTRL.BAKP can be used to remember this adjustment or not.

### 14.2.16 RTC sub-second register shift

When the value of calendar has a sub-second deviation compared to the external precision clock, the shift function can be used to improve the precision of calendar.

Calendar can use RTC\_SCTRL.SUB1S and RTC\_SCTRL.ADFS[14:0] bits to control maximum delay or advance

1s. The resolution of the adjustment is  $1/(\text{RTC\_PRE.DIVS}[14:0]+1)$  second, it means the higher value of  $\text{RTC\_PRE.DIVS}[14:0]$ , the higher of the resolution. However, to keep the synchronous prescaler output at 1Hz, the higher  $\text{RTC\_PRE.DIVS}[14:0]$  means the lower  $\text{RTC\_PRE.DIVA}[6:0]$ , then more power consuming.

Note: Before starting a shift operation, user must check  $\text{RTC\_SUBS.SS}[15]$  bit is 0.

Whenever write  $\text{RTC\_SCTRL}$  register, the  $\text{RTC\_INITSTS.SHOPF}$  flag will be set by hardware, which indicate a shift operation is pending. Once this shift operation is complete, the bit is cleared by hardware.

### 14.2.17 RTC digital clock precision calibration

Digital precision calibration is achieved by adjusting the number of RTC clock pulses in the calibration period. Digital precision calibration resolution is 0.954 PPM with the range from -487.1 PPM to +488.5 PPM.

When the input frequency is 32768 Hz, calibration period can be configured as  $2^{20}$   $\text{RTCCLK}$  cycles or 32 seconds. The precision calibration register ( $\text{RTC\_CALIB}$ ) indicates that there has  $\text{RTC\_CALIB.CM}[8:0]$   $\text{RTCCLK}$  clock cycles will be reduced during the specified period.

The value of  $\text{RTC\_CALIB.CM}[8:0]$  represents the number of  $\text{RTCCLK}$  pulses to be reduced during specified period. While  $\text{RTC\_CALIB.CP}$  can be used to increase 488.5 PPM, every  $2^{11}$   $\text{RTCCLK}$  cycles will inserts a  $\text{RTCCLK}$  pulse.

When using  $\text{RTC\_CALIB.CM}[8:0]$  and  $\text{RTC\_CALIB.CP}$  in combination, it can increase cycles range from -511 to +512  $\text{RTCCLK}$  cycles, and the calibration range from -487.1 ppm to +488.5 ppm, with the resolution is about 0.954 ppm.

*Note: When  $\text{RTC\_CALIB.CP} = 1$ ,  $\text{RTCCLK}$  is not inserted, and the RTC precision calibration function is unavailable.*

The effective calibrated frequency ( $f_{CAL}$ ) can be calculated by using the formula given below:

$$f_{CAL} = f_{RTCCLK} * \left( 1 + \frac{\text{RTC\_CALIB.CP} * 512 - \text{RTC\_CALIB.CM}[8:0]}{2^{20} + \text{RTC\_CALIB.CM}[8:0] - \text{RTC\_CALIB.CP} * 512} \right)$$

#### Calibrated when $\text{RTC\_PRE.DIVA}[6:0] < 3$

When the asynchronous prescaler value ( $\text{RTC\_PRE.DIVA}[6:0]$ ) is less than 3, the  $\text{RTC\_CALIB.CP}$  cannot be programmed to 1, and  $\text{RTC\_CALIB.CP}$  value will be ignored if the it has been set to 1.

When  $\text{RTC\_PRE.DIVA}[6:0] < 3$ , the value of  $\text{RTC\_PRE.DIVS}[14:0]$  should be decrease. Assume  $\text{RTCCLK}$  frequency is 32768Hz:

- When  $\text{RTC\_PRE.DIVA}[6:0] = 2$ ,  $\text{RTC\_PRE.DIVS}[14:0] = 8189$ .
- When  $\text{RTC\_PRE.DIVA}[6:0] = 1$ ,  $\text{RTC\_PRE.DIVS}[14:0] = 16379$ .
- When  $\text{RTC\_PRE.DIVA}[6:0] = 0$ ,  $\text{RTC\_PRE.DIVS}[14:0] = 32759$ .

The effective calibrated frequency ( $f_{CAL}$ ) can be calculated by using the formula given below:

$$f_{CAL} = f_{RTCCLK} * \left( 1 + \frac{256 - \text{RTC\_CALIB.CM}[8:0]}{2^{20} + \text{RTC\_CALIB.CM}[8:0] - 265} \right)$$

#### Verify RTC calibration

RTC output 1Hz waveform for measuring and verifying RTC precision.

Up to 2  $\text{RTCCLK}$  cycles measurement error may occur when measure the RTC frequency in a limit measurement

period. If the measurement period is the same as calibration period, the error can be eliminated.

- The calibration period is 32 seconds (default).

Using an accurate 32-second period to measure the 1Hz calibration output can ensure that the measurement error is within 0.447ppm (0.5 RTCCLK cycles within 32 seconds).

- The calibration period is 16 seconds.

Using an accurate 16-second period to measure the 1Hz calibration output can ensure that the measurement error is within 0.954ppm (0.5 RTCCLK cycles within 16 seconds).

- The calibration period is 8 seconds.

Using an accurate 8-second period to measure the 1Hz calibration output can ensure that the measurement error is within 1.907ppm (0.5 RTCCLK cycles within 8 seconds).

### Dynamic recalibration

When `RTC_INITSTS.INITF=0`, `RTC_CALIB` register can update by using following steps:

- Wait `RTC_INITSTS.RECPF=0`.
- A new value is written to the `RTC_CALIB`, then `RTC_INITSTS.RECPF` is automatically set to 1.
- The new calibration settings will take effect within 3 `ck_apre` cycles after a data write to the `RTC_CALIB`.

## 14.2.18 RTC low power mode

The working state of RTC in low power mode.

| Lower Power Mode | RTC Working State                                      | Exit Low Power Mode                                   |
|------------------|--|---|
| SLEEP            | Normal work  | RTC interrupt   |
| STOP0            | Normal work when the clock source of RTC is LSE or LSI | Alarm A, Alarm B, Periodic Wakeup and Timestamp event |
| STOP2            | Normal work when the clock source of RTC is LSE or LSI | Alarm A, Alarm B, Periodic Wakeup and Timestamp event |
| STANDBY          | Normal work when the clock source of RTC is LSE or LSI | Alarm and Alarm B                                     |

## 14.3 RTC Registers

### 14.3.1 RTC Register overview

Table 14-2 RTC register overview

| Offset | Register    | 31       | 30 | 29 | 28 | 27 | 26 | 25 | 24 | 23 | 22 | 21       | 20       | 19 | 18       | 17       | 16 | 15       | 14       | 13       | 12       | 11       | 10 | 9        | 8        | 7        | 6        | 5        | 4 | 3 | 2 | 1 | 0 |   |   |
|--------|-------------|----------|----|----|----|----|----|----|----|----|----|----------|----------|----|----------|----------|----|----------|----------|----------|----------|----------|----|----------|----------|----------|----------|----------|---|---|---|---|---|---|---|
| 000h   | RTC_TSH     | Reserved |    |    |    |    |    |    |    |    |    | APM      | HOT[1:0] |    |          | HOU[3:0] |    |          | Reserved | MIT[2:0] |          | MIU[3:0] |    |          | Reserved | SCT[2:0] |          | SCU[3:0] |   |   |   |   |   |   |   |
|        | Reset Value |          |    |    |    |    |    |    |    |    |    | 0        | 0        | 0  | 0        | 0        | 0  | 0        | 0        | 0        | 0        | 0        | 0  | 0        | 0        | 0        | 0        | 0        | 0 | 0 | 0 | 0 | 0 | 0 | 0 |
| 004h   | RTC_DATE    | Reserved |    |    |    |    |    |    |    |    |    | YRT[3:0] |          |    | YRU[3:0] |          |    | WDU[2:0] |          | MOT      | MOU[3:0] |          |    | Reserved | DAT[1:0] |          | DAU[3:0] |          |   |   |   |   |   |   |   |
|        | Reset Value |          |    |    |    |    |    |    |    |    |    | 0        | 0        | 0  | 0        | 0        | 0  | 0        | 0        | 0        | 0        | 1        | 0  | 0        | 0        | 0        | 0        | 1        | 0 | 0 | 0 | 0 | 0 | 0 | 0 |

| Offset | Register    | 31       | 30       | 29       | 28           | 27 | 26       | 25       | 24 | 23    | 22          | 21        | 20       | 19       | 18       | 17   | 16          | 15         | 14         | 13       | 12       | 11     | 10        | 9        | 8         | 7        | 6        | 5     | 4    | 3        | 2     | 1            | 0     |       |   |   |   |   |   |   |   |   |   |
|--------|-------------|----------|----------|----------|--------------|----|----------|----------|----|-------|-------------|-----------|----------|----------|----------|------|-------------|------------|------------|----------|----------|--------|-----------|----------|-----------|----------|----------|-------|------|----------|-------|--------------|-------|-------|---|---|---|---|---|---|---|---|---|
| 008h   | RTC_CTRL    | Reserved |          |          |              |    |          |          |    | COEN  | OUTSEL[1:0] |           |          | OPOL     | CALOSEL  | BAKP | SUIH        | ADIH       | Reserved   | WTEN     | ALBEN    | ALAIEN | TSEN      | WTEN     | ALBEN     | ALAIEN   | Reserved | HEMT  | BYPS | Reserved | TSPOL | WKUPSEL[2:0] |       | 0     |   |   |   |   |   |   |   |   |   |
|        | Reset Value | 0        |          |          |              |    |          |          |    | 0     | 0           | 0         | 0        | 0        | 0        | 0    | 0           | 0          | 0          | 0        | 0        | 0      | 0         | 0        | 0         | 0        | 0        | 0     | 0    | 0        | 0     | 0            | 0     | 0     | 0 | 0 | 0 |   |   |   |   |   |   |
| 00Ch   | RTC_INITSTS | Reserved |          |          |              |    |          |          |    |       |             |           |          |          |          |      | RECPF       | Reserved   |            |          |          | TISOVF | TISF      | WTF      | ALBF      | ALAF     | INITM    | INITF | RSYF | INITSF   | SHOPF | WTWF         | ALBWF | ALAWF | 0 |   |   |   |   |   |   |   |   |
|        | Reset Value | 0        |          |          |              |    |          |          |    |       |             |           |          |          |          |      | 0           | 0          |            |          |          | 0      | 0         | 0        | 0         | 0        | 0        | 0     | 0    | 0        | 0     | 0            | 0     | 0     | 0 | 0 | 0 | 0 | 0 | 0 | 0 | 0 | 0 |
| 010h   | RTC_PRE     | Reserved |          |          |              |    |          |          |    |       |             | DIVA[6:0] |          |          |          |      |             | Reserved   | DIVS[14:0] |          |          |        |           |          |           |          |          |       |      |          |       |              |       |       |   |   |   |   |   |   |   |   |   |
|        | Reset Value | 1        |          |          |              |    |          |          |    |       |             | 1         | 1        | 1        | 1        | 1    | 1           | 1          | 1          | 1        | 1        | 1      | 1         | 1        | 1         | 1        | 1        | 1     | 1    | 1        | 1     | 1            | 1     | 1     | 1 | 1 | 1 | 1 |   |   |   |   |   |
| 014h   | RTC_WKUPT   | Reserved |          |          |              |    |          |          |    |       |             |           |          |          |          |      | WKUPT[15:0] |            |            |          |          |        |           |          |           |          |          |       |      |          |       |              |       |       |   |   |   |   |   |   |   |   |   |
|        | Reset Value | 1        |          |          |              |    |          |          |    |       |             |           |          |          |          |      | 1           | 1          | 1          | 1        | 1        | 1      | 1         | 1        | 1         | 1        | 1        | 1     | 1    | 1        | 1     | 1            | 1     | 1     | 1 | 1 | 1 | 1 | 1 | 1 | 1 | 1 | 1 |
| 01Ch   | RTC_ALARMA  | MASK4    | WKDSEL   | DTT[1:0] |              |    | DTU[3:0] |          |    | MASK3 | APM         | HOT[1:0]  |          | HOU[3:0] |          |      | MASK2       | MIT[2:0]   |            | MIU[3:0] |          |        | MASK1     | SET[2:0] |           | SEU[3:0] |          |       |      |          |       |              |       |       |   |   |   |   |   |   |   |   |   |
|        | Reset Value | 0        | 0        | 0        | 0            | 0  | 0        | 0        | 0  | 0     | 0           | 0         | 0        | 0        | 0        | 0    | 0           | 0          | 0          | 0        | 0        | 0      | 0         | 0        | 0         | 0        | 0        | 0     | 0    | 0        | 0     | 0            | 0     |       |   |   |   |   |   |   |   |   |   |
| 020h   | RTC_ALARMB  | MASK4    | WKDSEL   | DTT[1:0] |              |    | DTU[3:0] |          |    | MASK3 | APM         | HOT[1:0]  |          | HOU[3:0] |          |      | MASK2       | MIT[2:0]   |            | MIU[3:0] |          |        | MASK1     | SET[2:0] |           | SEU[3:0] |          |       |      |          |       |              |       |       |   |   |   |   |   |   |   |   |   |
|        | Reset Value | 0        | 0        | 0        | 0            | 0  | 0        | 0        | 0  | 0     | 0           | 0         | 0        | 0        | 0        | 0    | 0           | 0          | 0          | 0        | 0        | 0      | 0         | 0        | 0         | 0        | 0        | 0     | 0    | 0        | 0     | 0            | 0     |       |   |   |   |   |   |   |   |   |   |
| 024h   | RTC_WRP     | Reserved |          |          |              |    |          |          |    |       |             |           |          |          |          |      |             |            |            |          |          |        |           |          | PKEY[7:0] |          |          |       |      |          |       |              |       |       |   |   |   |   |   |   |   |   |   |
|        | Reset Value | 0        |          |          |              |    |          |          |    |       |             |           |          |          |          |      |             |            |            |          |          |        |           |          | 0         | 0        | 0        | 0     |      |          |       |              |       |       |   |   |   |   |   |   |   |   |   |
| 028h   | RTC_SUBS    | Reserved |          |          |              |    |          |          |    |       |             |           |          |          |          |      | SS[15:0]    |            |            |          |          |        |           |          |           |          |          |       |      |          |       |              |       |       |   |   |   |   |   |   |   |   |   |
|        | Reset Value | 0        |          |          |              |    |          |          |    |       |             |           |          |          |          |      | 0           | 0          | 0          | 0        | 0        | 0      | 0         | 0        | 0         | 0        | 0        | 0     | 0    | 0        | 0     | 0            | 0     | 0     | 0 | 0 | 0 | 0 | 0 | 0 | 0 | 0 |   |
| 02Ch   | RTC_SCTRL   | SUBIS    | Reserved |          |              |    |          |          |    |       |             |           |          |          |          |      |             | ADFS[14:0] |            |          |          |        |           |          |           |          |          |       |      |          |       |              |       |       |   |   |   |   |   |   |   |   |   |
|        | Reset Value | 0        | 0        |          |              |    |          |          |    |       |             |           |          |          |          |      |             | 0          | 0          | 0        | 0        | 0      | 0         | 0        | 0         | 0        | 0        | 0     | 0    | 0        | 0     | 0            | 0     | 0     | 0 | 0 | 0 | 0 | 0 | 0 | 0 | 0 |   |
| 030h   | RTC_TST     | Reserved |          |          |              |    |          |          |    |       |             | APM       | HOT[1:0] |          | HOU[3:0] |      |             | Reserved   | MIT[2:0]   |          | MIU[3:0] |        |           | Reserved | SET[2:0]  |          | SEU[3:0] |       |      |          |       |              |       |       |   |   |   |   |   |   |   |   |   |
|        | Reset Value | 0        |          |          |              |    |          |          |    |       |             | 0         | 0        | 0        | 0        | 0    | 0           | 0          | 0          | 0        | 0        | 0      | 0         | 0        | 0         | 0        | 0        | 0     | 0    | 0        | 0     | 0            | 0     | 0     | 0 | 0 |   |   |   |   |   |   |   |
| 034h   | RTC_TSD     | Reserved |          |          |              |    |          |          |    |       |             | YRT[3:0]  |          |          | YRU[3:0] |      |             | WDU[2:0]   |            | MOT      | MOU[3:0] |        |           | Reserved | DAT[1:0]  |          | DAU[3:0] |       |      |          |       |              |       |       |   |   |   |   |   |   |   |   |   |
|        | Reset Value | 0        |          |          |              |    |          |          |    |       |             | 0         | 0        | 0        | 0        | 0    | 0           | 0          | 0          | 0        | 0        | 0      | 0         | 0        | 0         | 0        | 0        | 0     | 0    | 0        | 0     | 0            | 0     | 0     | 0 | 0 |   |   |   |   |   |   |   |
| 038h   | RTC_TSSS    | Reserved |          |          |              |    |          |          |    |       |             |           |          |          |          |      | SSE[15:0]   |            |            |          |          |        |           |          |           |          |          |       |      |          |       |              |       |       |   |   |   |   |   |   |   |   |   |
|        | Reset Value | 0        |          |          |              |    |          |          |    |       |             |           |          |          |          |      | 0           | 0          | 0          | 0        | 0        | 0      | 0         | 0        | 0         | 0        | 0        | 0     | 0    | 0        | 0     | 0            | 0     | 0     | 0 | 0 | 0 | 0 | 0 | 0 | 0 | 0 | 0 |
| 03Ch   | RTC_CALIB   | Reserved |          |          |              |    |          |          |    |       |             |           |          |          |          |      | CP          | CW8        | CW16       | Reserved |          |        |           | CM[8:0]  |           |          |          |       |      |          |       |              |       |       |   |   |   |   |   |   |   |   |   |
|        | Reset Value | 0        |          |          |              |    |          |          |    |       |             |           |          |          |          |      | 0           | 0          | 0          | 0        |          |        |           | 0        | 0         | 0        | 0        | 0     | 0    | 0        | 0     | 0            | 0     | 0     | 0 | 0 | 0 | 0 | 0 | 0 | 0 | 0 |   |
| 044h   | RTC_ALRMAS  | Reserved |          |          | MASKSSA[3:0] |    |          | Reserved |    |       |             |           |          |          |          |      |             |            |            |          |          |        | SSV[14:0] |          |           |          |          |       |      |          |       |              |       |       |   |   |   |   |   |   |   |   |   |
|        | Reset Value | 0        |          |          | 0            | 0  | 0        | 0        |    |       |             |           |          |          |          |      |             |            |            |          |          |        | 0         |          |           |          |          |       |      |          |       |              |       |       |   |   |   |   |   |   |   |   |   |
| 048h   | RTC_ALRMBSS | Reserved |          |          | MASKSSB[3:0] |    |          | Reserved |    |       |             |           |          |          |          |      |             |            |            |          |          |        | SSV[14:0] |          |           |          |          |       |      |          |       |              |       |       |   |   |   |   |   |   |   |   |   |
|        | Reset Value | 0        |          |          | 0            | 0  | 0        | 0        |    |       |             |           |          |          |          |      |             |            |            |          |          |        | 0         |          |           |          |          |       |      |          |       |              |       |       |   |   |   |   |   |   |   |   |   |
| 04Ch   | RTC_OPT     | Reserved |          |          |              |    |          |          |    |       |             |           |          |          |          |      |             |            |            |          |          |        |           |          |           |          | TYPE     |       |      |          |       |              |       |       |   |   |   |   |   |   |   |   |   |
|        | Reset Value | 0        |          |          |              |    |          |          |    |       |             |           |          |          |          |      |             |            |            |          |          |        |           |          |           |          | 0        |       |      |          |       |              |       |       |   |   |   |   |   |   |   |   |   |

### 14.3.2 RTC Calendar Time Register (RTC\_TSH)

Address offset: 0x00

Reset value: 0x0000 0000

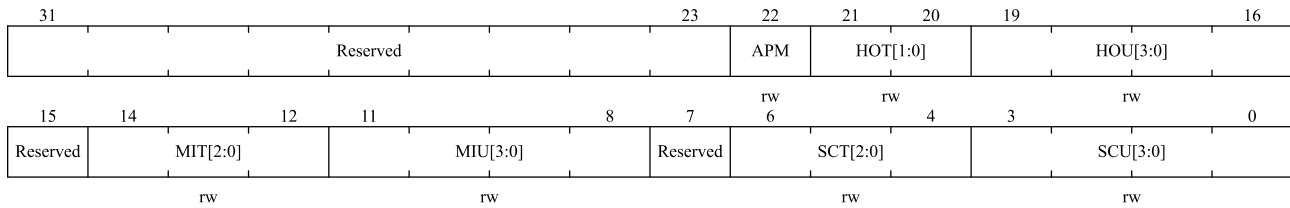

| Bit field | Name       | Description   |
|-----------|------------|---|
| 31:23     | Reserved   | Reserved, the reset value must be maintained                  |
| 22        | APM        | AM/PM format.<br>0:AM format or 24-hour format<br>1:PM format |
| 21:20     | HOT[1:0]   | Describes the hour tens value in BCD format                   |
| 19:16     | HOU[3:0]   | Describes the hour units value in BCD format                  |
| 15        | Reserved   | Reserved, the reset value must be maintained                  |
| 14:12     | MIT [2: 0] | Describes the minute tens value in BCD format                 |
| 11:8      | MIU[3:0]   | Describes the minute units value in BCD format                |
| 7         | Reserved   | Reserved, the reset value must be maintained                  |
| 6:4       | SCT[2:0]   | Describes the second tens value in BCD format                 |
| 3:0       | SCU[3:0]   | Describes the second units value in BCD format                |

### 14.3.3 RTC Calendar Date Register (RTC\_DATE)

Address offset: 0x04

Reset value: 0x0000 2101

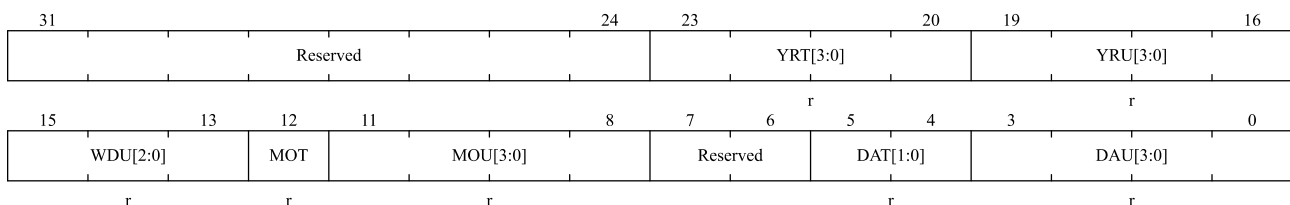

| Bit field | Name     | Description   |
|-----------|----------|---|
| 31:24     | Reserved | Reserved, the reset value must be maintained                                    |
| 23:20     | YRT[3:0] | Describes the year tens value in BCD format                                     |
| 19:16     | YRU[3:0] | Describes the year units value in BCD format                                    |
| 15:13     | WDU[2:0] | Describes which Week day<br>000: Forbidden<br>001: Monday<br>...<br>111: Sunday |
| 12        | MOT      | Describes the month tens value in BCD format                                    |
| 11:8      | MOU[3:0] | Describes the month units value in BCD format                                   |
| 7:6       | Reserved | Reserved, the reset value must be maintained                                    |



| Bit field | Name     | Description   |
|-----------|----------|---|
|           |          | 1: Subtracts 1 hour to the current time.  |
| 16        | AD1H     | Add 1 hour (summer time change)<br>When this bit is set, 1 hour can be added to the calendar time. This bit is always read as.<br>0: No effect.<br>1: Adds 1 hour to the current time.  |
| 15        | Reserved | Reserved, the reset value must be maintained  |
| 14        | WTIEN    | Wakeup timer interrupt enable<br>0: Disable wakeup timer interrupt.<br>1: Enable wakeup timer interrupt.  |
| 13        | ALBIEN   | Alarm B interrupt enable<br>0: Disable Alarm B interrupt<br>1: Enable Alarm B Interrupt   |
| 12        | ALAIEN   | Alarm A interrupt enable<br>0: Disable Alarm A interrupt<br>1: Enable Alarm A interrupt   |
| 11        | TSEN     | Timestamp enable<br>0: Disable timestamp<br>1: Enable timestamp   |
| 10        | WTEN     | Wakeup timer enable<br>0: Disable wakeup timer<br>1: Enable wakeup timer  |
| 9         | ALBEN    | Alarm B enable<br>0: Disable Alarm B<br>1: Enable Alarm B   |
| 8         | ALAEN    | Alarm A enable<br>0: Disable Alarm A<br>1: Enable Alarm A   |
| 7         | Reserved | Reserved, the reset value must be maintained  |
| 6         | HFMT     | Hour format bit<br>0: 24 hour format<br>1: Am/PM format   |
| 5         | BYPS     | Bypass values from the shadow registers<br>0: Calendar values are copied from the shadow registers, which are refreshed every two RTCCLK cycles.<br>1: Calendar values are copied directly from the calendar counters.<br><i>Note: If the frequency of the APB1 clock falls below seven times the frequency of RTCCLK, RTC_CTRL.BYPS bit must be set to '1'</i> |
| 4         | Reserved | Reserved, the reset value must be maintained  |
| 3         | TSPOL    | Time-stamp event active edge<br>0: Input rising edge creates a timestamp event<br>1: Input falling edge creates a timestamp event<br>TSE need to be reset when TSPOL is changed to avoid unwanted RTC_INITSTS.TISF setting.   |

| Bit field | Name         | Description   |
|-----------|--------------|---|
| 2:0       | WKUPSEL[2:0] | Wakeup clock selection<br>000: RTC clock is divided by 16<br>001: RTC clock is divided by 8<br>010: RTC clock is divided by 4<br>011: RTC clock is divided by 2<br>10x: ck_spre (usually 1Hz) clock is selected |

### 14.3.5 RTC Initial Status Register (RTC\_INITSTS)

Address offset: 0x0C

Reset value: 0x0000 0007

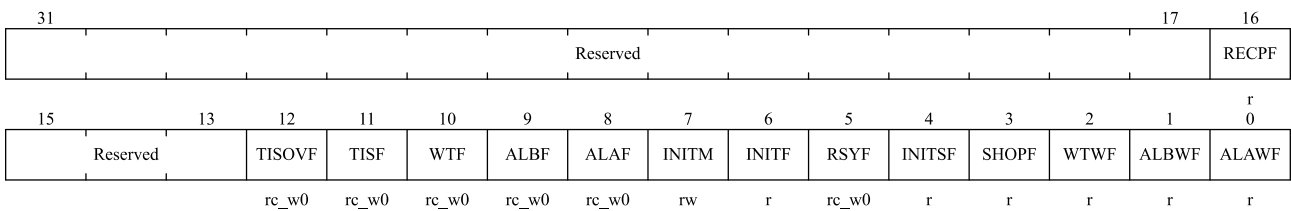

| Bit field | Name     | Description  |
|-----------|----------|--|
| 31:17     | Reserved | Reserved, the reset value must be maintained   |
| 16        | RECPF    | Recalibration pending flag<br>The RECPF status flag is automatically set to '1' when software writes to the RTC_CALIB register, indicating that the RTC_CALIB register is blocked. After the new calibration settings are processed, this bit returns to '0'.  |
| 15:13     | Reserved | Reserved, the reset value must be maintained   |
| 12        | TISOVF   | The time-stamp overflow flag<br>This flag is set to '1' by hardware when a time-stamp event happens when TISF bit is set.<br>This flag can be cleared by software writing 0. It is advised to check and clear TISOVF only after clearing the TISF bit. Otherwise, an overflow might not be noticed if a timestamp event occurs immediately before the TISF bit is being cleared. |
| 11        | TISF     | Time-stamp flag<br>This flag is set to '1' by hardware when a time-stamp event happens.<br>This flag can be cleared by software writing 0  |
| 10        | WTF      | Wake up timer flag<br>This flag is set by hardware when the value of wakeup auto-reload counter reaches 0.<br>This flag is cleared by software by writing 0.<br>This flag must be cleared by software at least 1.5 RTCCLK periods before WTF is set again.   |
| 9         | ALBF     | Alarm B flag<br>This flag is set to '1' by hardware when the time/date registers value match the Alarm B register values.<br>This flag can be cleared by software writing 0  |

| Bit field | Name   | Description  |
|-----------|--------|--|
| 8         | ALAF   | Alarm A flag<br>This flag is set to '1' by hardware when the time/date registers value match the Alarm A register values.<br>This flag can be cleared by software writing 0  |
| 7         | INITM  | Enter Initialization mode<br>0: Free running mode<br>1: Enter initialization mode and set calendar time value, date value, and prescale value.   |
| 6         | INITF  | Initialization flag<br>RTC is in initialization state when this bit is '1', and calendar time, date and prescale value can be updated.<br>0: Calendar time, date and prescale value can not be updated<br>1: Calendar time, date and prescale value can be updated   |
| 5         | RSYF   | Register synchronization flag<br>This flag is set to '1' by hardware when the calendar value are copied into the shadow registers. This bit is cleared by hardware when in initialization mode, while a shift operation is pending (SHOPF = 1), or when in bypass shadow register mode (RTC_CTRL.BYPS = 1). This bit can also be cleared by software.<br>It is cleared either by software or by hardware in initialization mode.<br>0: Calendar shadow register not yet synchronized<br>1: Calendar shadow register synchronized |
| 4         | INITSF | Initialization status flag<br>This flag is set to '1' by hardware when the calendar year field is different from 0 (which is the RTC domain reset state).<br>0: Calendar has not been initialized<br>1: Calendar has been initialized  |
| 3         | SHOPF  | Shift operation pending flag<br>This flag is set to '1' by hardware as soon as a shift operation is initiated by a write to the RTC_SCTRL register. It is cleared by hardware when the corresponding shift operation has been completed, note that writing to the SHOPF bit has no effect.<br>0: No shift operation is pending<br>1: A shift operation is pending  |
| 2         | WTWF   | Wakeup timer write flag<br>0: Wakeup timer configuration update is not allowed<br>1: Wakeup timer configuration update is allowed  |
| 1         | ALBWF  | Alarm B write flag<br>This flag is set to '1' by hardware when Alarm B values can be changed, after the RTC_CTRL.ALBEN bit has been set to 0.<br>0: Alarm B update is not allowed<br>1: Alarm B update is allowed  |
| 0         | ALAWF  | Alarm A write flag.<br>This flag is set to '1' by hardware when Alarm A values can be changed, after the RTC_CTRL.ALAEN bit has been set to 0.   |

| Bit field | Name | Description  |
|-----------|------|--|
|           |      | 0: Alarm A update is not allowed<br>1: Alarm A update is allowed |

### 14.3.6 RTC Prescaler Register (RTC\_PRE)

Address offset: 0x10

Reset value: 0x007F 00FF

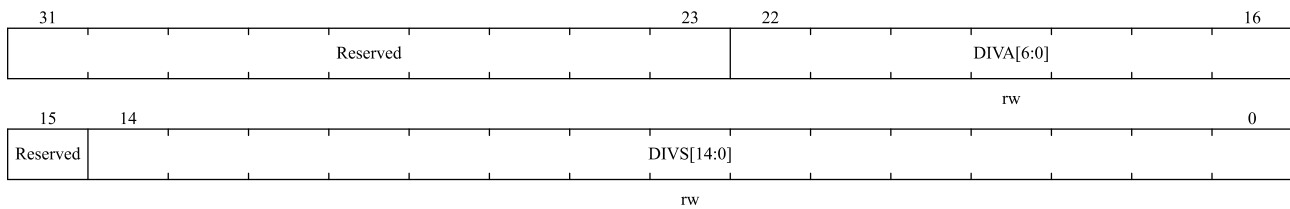

| Bit field | Name       | Description  |
|-----------|------------|--|
| 31:23     | Reserved   | Reserved, the reset value must be maintained                                     |
| 22:16     | DIVA[6:0]  | Asynchronous prescaler factor<br>$f_{ck\_apre} = RTCCLK / (DIVA[6:0] + 1)$       |
| 15        | Reserved   | Reserved, the reset value must be maintained                                     |
| 14:0      | DIVS[14:0] | Synchronous prescaler factor<br>$f_{ck\_spre} = f_{ck\_apre} / (DIVS[14:0] + 1)$ |

### 14.3.7 RTC Wakeup Timer Register (RTC\_WKUPT)

Address offset: 0x14

Reset value: 0x0000 FFFF

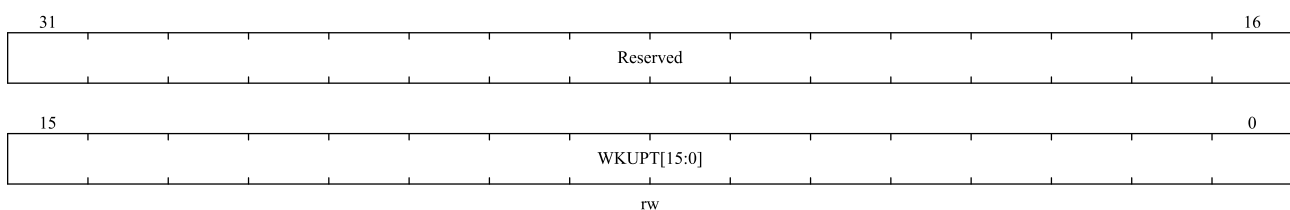

| Bit field | Name        | Description   |
|-----------|-------------|---|
| 31:16     | Reserved    | Reserved, the reset value must be maintained  |
| 15:0      | WKUPT[15:0] | Wake up auto-reload value bits<br>The RTC_INITSTS.WTF flag is set every (WKUPT[15:0] + 1) ck_wut cycles when the RTC_CTRL.WTEN=1. When RTC_CTRL.WKUPSEL[2:0]=0b10x, N = WKUPT[15:0] + 1; When RTC_CTRL.WKUPSEL[2:0]=0b11x, N = (WKUPT[15:0] + 1) + 65536.<br><i>Note:</i><br>Changes to this register (e.g., the second or subsequent settings) need to be made immediately upon entering the wakeup interrupt (first disable wakeup, then set this |

| Bit field | Name | Description                                    |
|-----------|------|--|
|           |      | <i>register, and then enable wakeup again)</i> |

### 14.3.8 RTC Alarm A Register (RTC\_ALARM\_A)

Address offset: 0x1C

Reset value: 0x0000 0000

|       |          |          |          |          |    |       |          |     |          |    |          |
|-------|----------|----------|----------|----------|----|-------|----------|-----|----------|----|----------|
| 31    | 30       | 29       | 28       | 27       | 24 | 23    | 22       | 21  | 20       | 19 | 16       |
| MASK4 | WKDSEL   | DTT[1:0] |          | DTU[3:0] |    |       | MASK3    | APM | HOT[1:0] |    | HOU[3:0] |
| rw    | rw       | rw       |          | rw       |    |       | rw       | rw  | rw       |    | rw       |
| 15    | 14       | 12       | 11       | 8        | 7  | 6     | 4        | 3   | 0        |    |          |
| MASK2 | MIT[2:0] |          | MIU[3:0] |          |    | MASK1 | SET[2:0] |     | SEU[3:0] |    |          |
| rw    | rw       |          | rw       |          |    | rw    | rw       |     | rw       |    |          |

| Bit field | Name     | Description   |
|-----------|----------|---|
| 31        | MASK4    | Alarm date mask<br>0: Date/day match<br>1: Date/day not match   |
| 30        | WKDSEL   | Week day selection<br>0: DTU[3:0] represents the date units<br>1: DTU[3:0] represents week day only. DTT[1:0] is not considered |
| 29:28     | DTT[1:0] | Describes the date tens value in BCD format   |
| 27:24     | DTU[3:0] | Describes the date units value in BCD format  |
| 23        | MASK3    | Alarm hours mask<br>0: Hours match<br>1: Hours not match  |
| 22        | APM      | AM/PM notation<br>0: AM or 24 hours format<br>1: PM format  |
| 21:20     | HOT[1:0] | Describes the hour tens value in BCD format   |
| 19:16     | HOU[3:0] | Describes the hour units value in BCD format  |
| 15        | MASK2    | Alarm minutes mask<br>0: Minutes match<br>1: Minutes not match  |
| 14:12     | MIT[2:0] | Describes the minute tens value in BCD format   |
| 11:8      | MIU[3:0] | Describes the minute units value in BCD format  |
| 7         | MASK1    | Alarm seconds mask<br>0: Seconds match<br>1: Seconds not match  |
| 6:4       | SET[2:0] | Describes the second tens value in BCD format   |
| 3:0       | SEU[3:0] | Describes the second units value in BCD format  |

### 14.3.9 RTC Alarm B Register (RTC\_ALARM B)

Address offset: 0x20

Reset value: 0x0000 0000

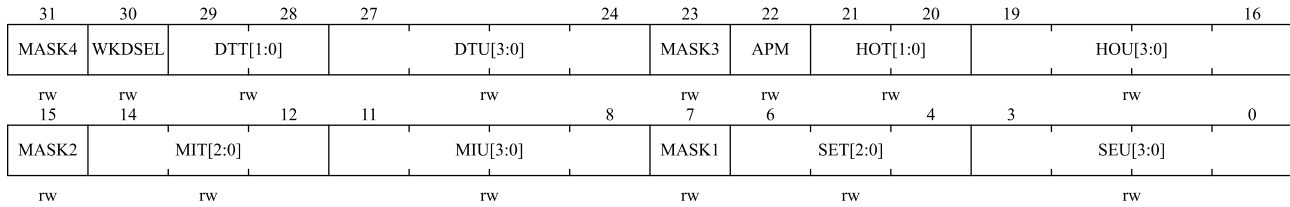

| Bit field | Name     | Description   |
|-----------|----------|---|
| 31        | MASK4    | Alarm date mask<br>0: Date/day match<br>1: Date/day not match   |
| 30        | WKDSEL   | Week day selection<br>0: DTU[3:0] represents the date units<br>1: DTU[3:0] represents week day only. DTT[1:0] is not considered |
| 29:28     | DTT[1:0] | Describes the date tens value in BCD format   |
| 27:24     | DTU[3:0] | Describes the date units value in BCD format  |
| 23        | MASK3    | Alarm hours mask<br>0: Hours match<br>1: Hours not match  |
| 22        | APM      | AM/PM notation<br>0: AM or 24 hours format<br>1: PM format  |
| 21:20     | HOT[1:0] | Describes the hour tens value in BCD format   |
| 19:16     | HOU[3:0] | Describes the hour units value in BCD format  |
| 15        | MASK2    | Alarm minutes mask<br>0: Minutes match<br>1: Minutes not match  |
| 14:12     | MIT[2:0] | Describes the minute tens value in BCD format   |
| 11:8      | MIU[3:0] | Describes the minute units value in BCD format  |
| 7         | MASK1    | Alarm seconds mask<br>0: Seconds match<br>1: Seconds not match  |
| 6:4       | SET[2:0] | Describes the second tens value in BCD format   |
| 3:0       | SEU[3:0] | Describes the second units value in BCD format  |

### 14.3.10 RTC Write Protection register (RTC\_WRP)

Address offset: 0x24

Reset value: 0x0000 0000

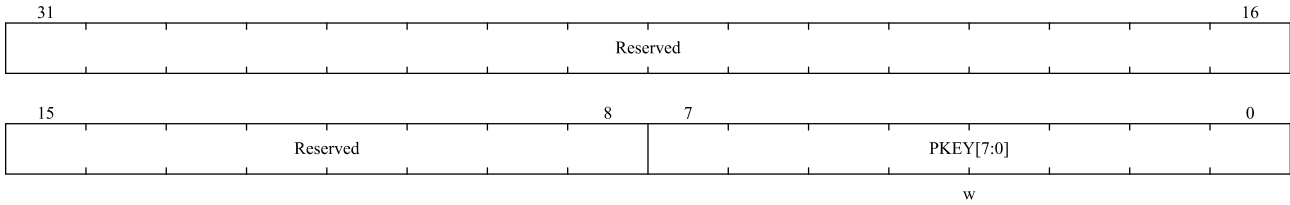

| Bit field | Name      | Description   |
|-----------|-----------|---|
| 31:8      | Reserved  | Reserved, the reset value must be maintained  |
| 7:0       | PKEY[7:0] | Write protection key<br>Reading this byte always returns 0x00.<br>For detail on how to unlock RTC register write protection, see chapter RTC write protection register. |

### 14.3.11 RTC Sub-second Register (RTC\_SUBS)

Address offset: 0x28

Reset value: 0x0000 0000

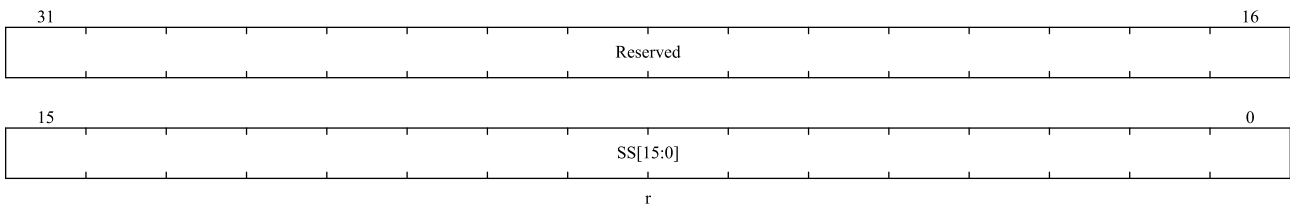

| Bit field | Name     | Description  |
|-----------|----------|--|
| 31:16     | Reserved | Reserved, the reset value must be maintained   |
| 15:0      | SS[15:0] | Sub-second value.<br>The value is the counter value of synchronous prescaler. This sub-second value is calculated by the below formula:<br>Sub-second value = (RTC_PRE.DIVS[14:0]-SS)/(RTC_PRE.DIVS[14:0]+1)<br><i>Note: SS[15:0] can be larger than RTC_PRE.DIVS[14:0] only after the shift operation is finished. In this case, the correct time/date is one second slower than the time/date indicated by RTC_TSH/RTC_DATE.</i> |

### 14.3.12 RTC Shift Control Register (RTC\_SCTRL)

Address offset: 0x2C

Reset value: 0x0000 0000

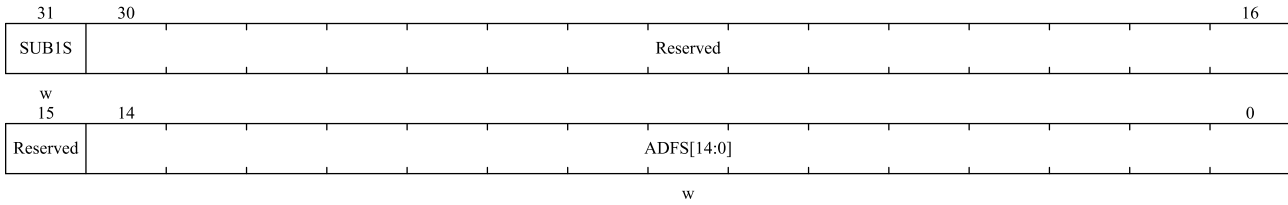

| Bit field | Name       | Description   |
|-----------|------------|---|
| 31        | SUBIS      | Add one second<br>0: No impact.<br>1: Subtract one second to the clock/calendar<br>This bit can only be written and read as zero. Writing to this bit does not have an impact when RTC_INITSTS.SHOPF=1.   |
| 30:15     | Reserved   | Reserved, the reset value must be maintained  |
| 14:0      | ADFS[14:0] | Add a fraction of a second<br>This bit is a write-only bit and is always read as 0. The value written to ADFS[14:0] will be subtracted by the synchronous prescaler counter. As the counter counts down, this operation can effectively speed up the following time from the clock:<br>Acceleration (seconds) = ADFS [14:0] / (DIVS[14:0] + 1)<br>SUBIS bit can be used together with the ADFS[14:0]bits:<br>Delay (seconds) = 1-(ADFS[14:0] / (DIVS[14:0] + 1)).<br><i>Note: Before writing ADFS[14:0], need to read the RTC_SUBS register to ensure that ADFS[14:0] &lt; RTC_SUBS.SS[15:0];</i> |

### 14.3.13 RTC Timestamp Time Register (RTC\_TST)

Address offset: 0x30

Reset value: 0x0000 0000

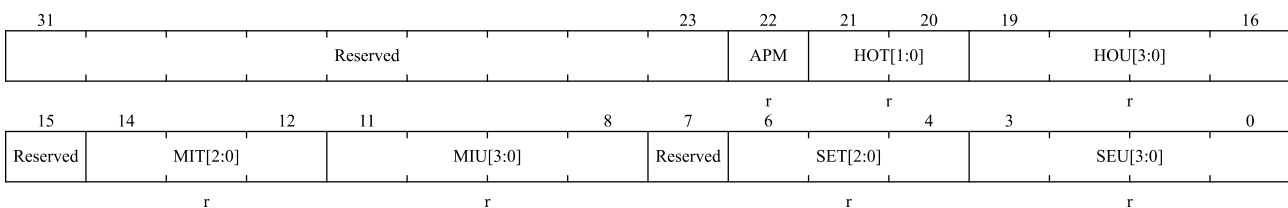

| Bit field | Name     | Description                                       |
|-----------|----------|---|
| 31:23     | Reserved | Reserved, the reset value must be maintained      |
| 22        | APM      | AM/PM notation<br>0: AM or 24-hour clock<br>1: PM |
| 21:20     | HOT[1:0] | Describes the hour tens value in BCD format       |
| 19:16     | HOU[3:0] | Describes the hour units value in BCD format      |
| 15        | Reserved | Reserved, the reset value must be maintained      |
| 14:12     | MIT[2:0] | Describes the minute tens value in BCD format     |

| Bit field | Name     | Description                                    |
|-----------|----------|--|
| 11:8      | MIU[3:0] | Describes the minute units value in BCD format |
| 7         | Reserved | Reserved, the reset value must be maintained   |
| 6:4       | SET[2:0] | Describes the second tens value in BCD format  |
| 3:0       | SEU[3:0] | Describes the second units value in BCD format |

### 14.3.14 RTC Timestamp Date Register (RTC\_TSD)

Address offset: 0x34

Reset value: 0x0000 0000

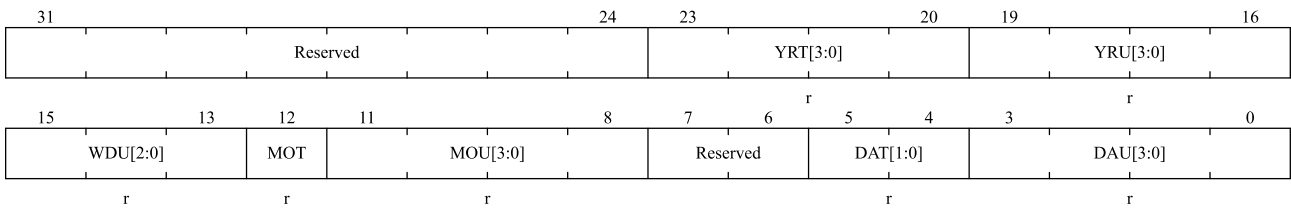

| Bit field | Name     | Description   |
|-----------|----------|---|
| 31:24     | Reserved | Reserved, the reset value must be maintained                                    |
| 23:20     | YRT[3:0] | Describes the year tens value in BCD format                                     |
| 19:16     | YRU[3:0] | Describes the year units value in BCD format                                    |
| 15:13     | WDU[2:0] | Describes which Week day<br>000: Forbidden<br>001: Monday<br>...<br>111: Sunday |
| 12        | MOT      | Describes the month tens value in BCD format                                    |
| 11:8      | MOU[3:0] | Describes the month units value in BCD format                                   |
| 7:6       | Reserved | Reserved, the reset value must be maintained                                    |
| 5:4       | DAT[1:0] | Describes the date tens value in BCD format                                     |
| 3:0       | DAU[3:0] | Describes the date units value in BCD format                                    |

### 14.3.15 RTC Timestamp Sub-second Register (RTC\_TSSS)

Address offset: 0x38

Reset value: 0x0000 0000

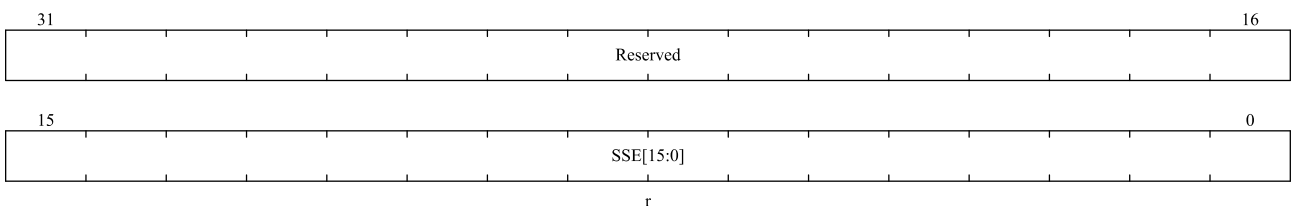

| Bit field | Name      | Description  |
|-----------|-----------|--|
| 31:16     | Reserved  | Reserved, the reset value must be maintained   |
| 15:0      | SSE[15:0] | Sub second value<br>SSE[15:0] is the value in the synchronous prescaler counter. The fraction of a second is provided by the formula below:<br>$\text{Second fraction} = (\text{RTC\_PRE.DIVS}[14:0] - \text{SSE}[15:0]) / (\text{RTC\_PRE.DIVS}[14:0] + 1)$ Note: SSE[15:0] can be larger than RTC_PRE.DIVS[14:0] only after a shift operation. In that case, the correct time/date is one second less than as indicated by RTC_TSH/RTC_DATE. |

### 14.3.16 RTC Calibration Register (RTC\_CALIB)

Address offset: 0x3C

Reset value: 0x0000 0000

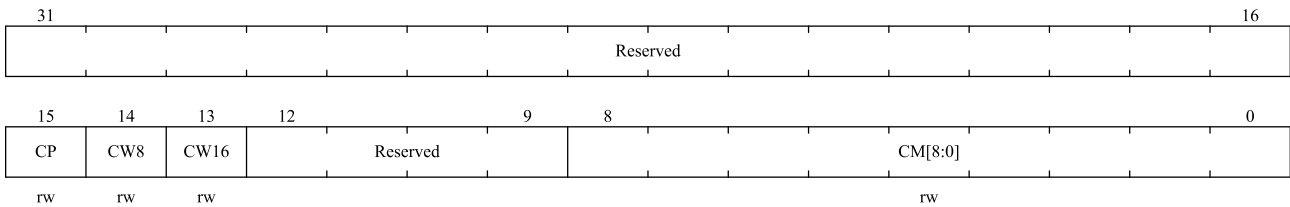

| Bit field | Name     | Description  |
|-----------|----------|--|
| 31:16     | Reserved | Reserved, the reset value must be maintained   |
| 15        | CP       | Increase frequency of RTC by 488.5 ppm<br>This feature is intended to be used along with CM[8:0]. When RTCCLK frequency is 32768 Hz, the number of RTCCLK pulses added during a 32-second window is $((512 * CP) - CM[8:0])$ .<br>0: No add pulse.<br>1: One RTCCLK pulse is inserted every $2^{11}$ pulses. |
| 14        | CW8      | Select an 8-second calibration cycle period<br>0: Not effect.<br>1: Select an 8-second calibration period.<br>When CW8 is set to '1', the 8-second calibration cycle period is selected.<br>Note: when CW8 = 1, CM[1:0] will always be '00'  |
| 13        | CW16     | To select a 16-second calibration cycle period<br>0: Not effect.<br>1: Select a calibration period of 16 seconds. If CW8 = 1, this bit cannot be set to 1.<br>Note: when CW16 = 1, CM[0] will always be '0'  |
| 12:9      | Reserved | Reserved, the reset value must be maintained   |
| 8:0       | CM[8:0]  | Negative calibration bits<br>The number of mask pulse out of $2^{20}$ RTCCLK pulses. This effectively decreases the frequency of the calendar with a resolution of 0.9537 ppm.   |

### 14.3.17 RTC Alarm A sub-second register (RTC\_ALRMAS)

Address offset: 0x44

Reset value: 0x0000 0000



| Bit field | Name         | Description   |
|-----------|--------------|---|
| 31:28     | Reserved     | Reserved, the reset value must be maintained  |
| 27:24     | MASKSSB[3:0] | Mask the most significant bit from this bits.<br>0x0: No comparison on sub seconds for Alarm. The alarm is set when the seconds unit is incremented (assuming that the rest of the fields match).<br>0x1: Only SSV[0] is compared and other bits are not compared.<br>0x2: Only SSV[1:0] are compared and other bits are not compared.<br>0x3: Only SSV[2:0] are compared and other bits are not compared.<br>...<br>0xC: Only SSV[11:0] are compared and other bits are not compared.<br>0xD: Only SSV[12:0] are compared and other bits are not compared.<br>0xE: Only SSV[13:0] are compared and other bits are not compared.<br>0xF: SSV[14:0] are compared<br>Synchronization counter RTC_SUBS.SS[15] bit is never compared. |
| 23:15     | Reserved     | Reserved, the reset value must be maintained  |
| 14:0      | SSV[14:0]    | Sub seconds value<br>This value is compared with the synchronous prescaler counter RTC_SUBS.SS[14:0], and bit number of compared is controlled by MASKSSB[3:0].   |

### 14.3.18 RTC Alarm B sub-second register (RTC\_ALRMBSS)

Address offset: 0x48

Reset value: 0x0000 0000

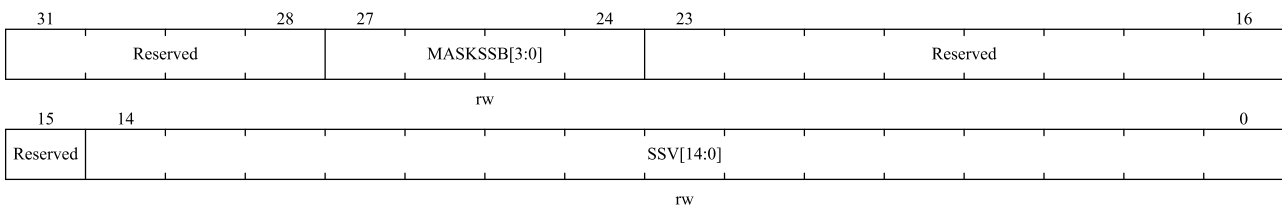

| Bit field | Name     | Description                                  |
|-----------|----------|--|
| 31:28     | Reserved | Reserved, the reset value must be maintained |

| Bit field | Name         | Description   |
|-----------|--------------|---|
| 27:24     | MASKSSB[3:0] | Mask the most significant bit from this bits.<br>0x0: No comparison on sub seconds for Alarm. The alarm is set when the seconds unit is incremented (assuming that the rest of the fields match).<br>0x1: Only SSV[0] is compared and other bits are not compared.<br>0x2: Only SSV[1:0] are compared and other bits are not compared.<br>0x3: Only SSV[2:0] are compared and other bits are not compared.<br>...<br>0xC: Only SSV[11:0] are compared and other bits are not compared.<br>0xD: Only SSV[12:0] are compared and other bits are not compared.<br>0xE: Only SSV[13:0] are compared and other bits are not compared.<br>0xF: SSV[14:0] are compared<br>Synchronization counter RTC_SUBS.SS[15] bit is never compared. |
| 23:15     | Reserved     | Reserved, the reset value must be maintained  |
| 14:0      | SSV[14:0]    | Sub seconds value<br>This value is compared with the synchronous prescaler counter RTC_SUBS.SS[14:0], and bit number of compared is controlled by MASKSSB[3:0].   |

### 14.3.19 RTC Option Register (RTC\_OPT)

Address offset: 0x4C

Reset value: 0x0000 0000

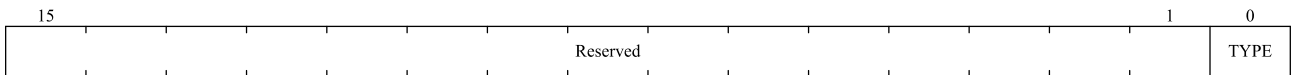
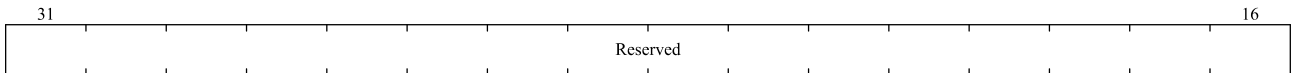

rw

| Bit field | Name     | Description  |
|-----------|----------|--|
| 31:1      | Reserved | Reserved, the reset value must be maintained                                 |
| 0         | TYPE     | RTC_ALARM output type on PC13<br>0: Open-drain output<br>1: Push-pull output |

## 15 CRC calculation unit

### 15.1 Introduction

This module integrates the functions of CRC32 and CRC16, and the cyclic redundancy check (CRC) calculation unit obtains any CRC calculation result according to a fixed generator polynomial. In other applications, CRC technology is mainly used to verify the correctness and integrity of data transmission or data storage. EN/IEC 60335-1 provides a method to verify the integrity of flash memory. CRC calculation unit can calculate the identifier of the software when the program is running, then compare it with the reference identifier generated during connection, and then store it in the specified memory space.

### 15.2 Main features

#### 15.2.1 CRC32

- $CRC32(X^{32} + X^{26} + X^{23} + X^{22} + X^{16} + X^{12} + X^{11} + X^{10} + X^8 + X^7 + X^5 + X^4 + X^2 + X + 1)$
- 32 bits of data to be checked and 32 bits of output check code.
- CRC calculation time: 1 AHB clock cycles (HCLK)
- General-purpose 8-bit register (can be used to store temporary data)

#### 15.2.2 CRC16

- $CRC16(X^{16} + X^{15} + X^2 + 1)$
- There are 8 bits of data to be checked and 16 bits of output check code.
- CRC calculation time: 1 AHB clock cycle (HCLK)
- The verification initial value can be configured, and the size end of the data to be verified can be configured.
- Support 8bit LRC check value generation

The following figure is the block diagram of CRC unit.

Figure 15-1 CRC calculation unit block diagram

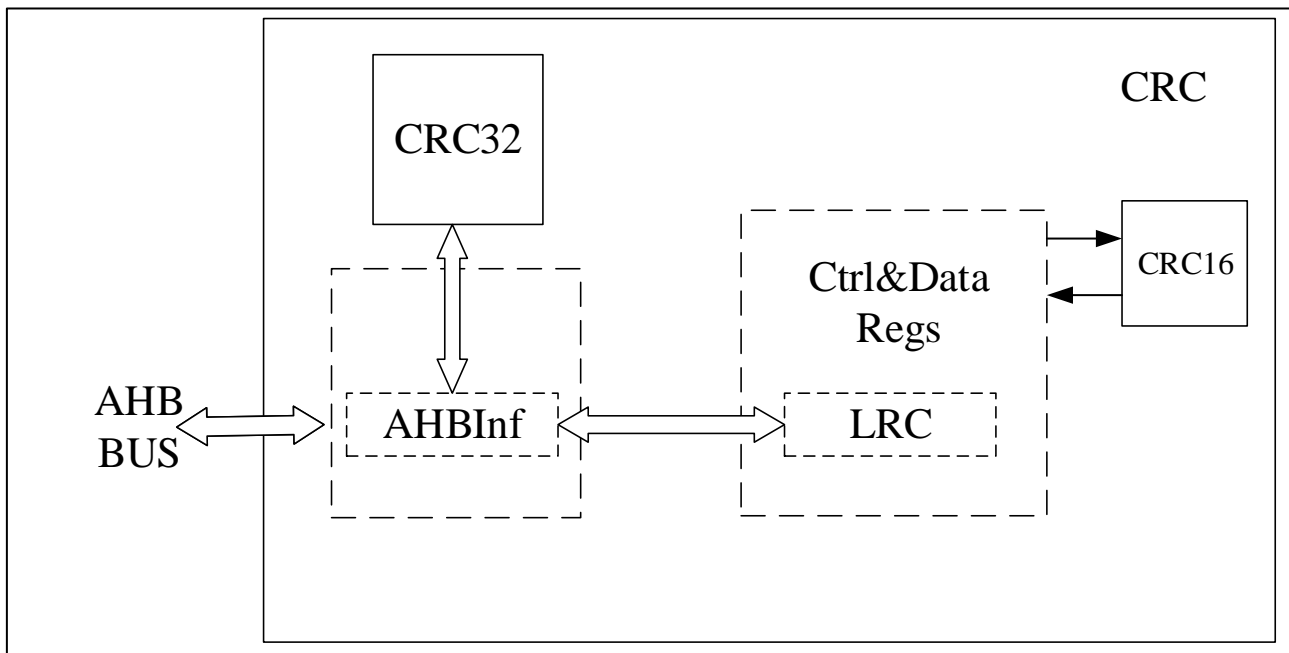

## 15.3 Function description

### 15.3.1 CRC32

CRC unit contains one 32-bit data register:

- Writing this register to input CRC data.
- Reading this register to get the calculated CRC result.

Every writing operation of this data register triggers the calculation of this new data with the previous calculation result (CRC calculation is performed on the whole 32-bit word rather than byte by byte).

Supports back-to-back writes or sequential write-read operations.

CRC\_CRC32DAT can be re-initialized to 0xFFFFFFFF by setting CRC\_CRC32CTRL.RESET. This operation does not affect the data in register CRC\_CRC32IDAT.

### 15.3.2 CRC16

The LSB or MSB of the check data is controlled by the CRC\_CRC16CTRL.ENDHL bit.

To clear the result of the last CRC operation, set CRC\_CRC16CTRL.CLR to 1 or CRC\_CRC16D to 0.

The initial value of CRC calculation can be configured by writing the CRC\_CRC16D register. By default, the initial value is the result of the last calculation.

LRC calculation is the same as CRC calculation. Both are carried out at the same time. CRC or LRC can be read out depending on needs. If the initial value needs to be set, the LRC register should be configured first.

## 15.4 CRC registers

### 15.4.1 CRC register overview

Table 15-1 CRC register overview

| Offset | Register    | 31             | 30 | 29 | 28 | 27 | 26 | 25 | 24 | 23 | 22 | 21 | 20 | 19 | 18 | 17 | 16           | 15 | 14 | 13 | 12 | 11 | 10 | 9 | 8 | 7              | 6 | 5 | 4 | 3   | 2     | 1        | 0     |
|--------|-------------|----------------|----|----|----|----|----|----|----|----|----|----|----|----|----|----|--------------|----|----|----|----|----|----|---|---|----------------|---|---|---|-----|-------|----------|-------|
| 000h   | CRC32DAT    | CRC32DAT[31:0] |    |    |    |    |    |    |    |    |    |    |    |    |    |    |              |    |    |    |    |    |    |   |   |                |   |   |   |     |       |          |       |
|        | Reset Value | 1              | 1  | 1  | 1  | 1  | 1  | 1  | 1  | 1  | 1  | 1  | 1  | 1  | 1  | 1  | 1            | 1  | 1  | 1  | 1  | 1  | 1  | 1 | 1 | 1              | 1 | 1 | 1 | 1   | 1     | 1        | 1     |
| 004h   | CRC32IDAT   | Reserved       |    |    |    |    |    |    |    |    |    |    |    |    |    |    |              |    |    |    |    |    |    |   |   | CRC32IDAT[7:0] |   |   |   |     |       |          |       |
|        | Reset Value |                |    |    |    |    |    |    |    |    |    |    |    |    |    |    |              |    |    |    |    |    |    |   |   | 0              | 0 | 0 | 0 | 0   | 0     | 0        | 0     |
| 008h   | CRC32CTRL   | Reserved       |    |    |    |    |    |    |    |    |    |    |    |    |    |    |              |    |    |    |    |    |    |   |   |                |   |   |   |     |       |          | RESET |
|        | Reset Value |                |    |    |    |    |    |    |    |    |    |    |    |    |    |    |              |    |    |    |    |    |    |   |   |                |   |   |   |     |       |          | 0     |
| 00Ch   | CRC16CTRL   | Reserved       |    |    |    |    |    |    |    |    |    |    |    |    |    |    |              |    |    |    |    |    |    |   |   |                |   |   |   | CLR | ENDHL | Reserved |       |
|        | Reset Value |                |    |    |    |    |    |    |    |    |    |    |    |    |    |    |              |    |    |    |    |    |    |   |   |                |   |   |   | 0   | 0     | 0        |       |
| 010h   | CRC16DAT    | Reserved       |    |    |    |    |    |    |    |    |    |    |    |    |    |    |              |    |    |    |    |    |    |   |   | CRC16DAT[7:0]  |   |   |   |     |       |          |       |
|        | Reset Value |                |    |    |    |    |    |    |    |    |    |    |    |    |    |    |              |    |    |    |    |    |    |   |   | 0              | 0 | 0 | 0 | 0   | 0     | 0        | 0     |
| 014h   | CRC16D      | Reserved       |    |    |    |    |    |    |    |    |    |    |    |    |    |    | CRC16D[15:0] |    |    |    |    |    |    |   |   |                |   |   |   |     |       |          |       |
|        | Reset Value |                |    |    |    |    |    |    |    |    |    |    |    |    |    |    | 0            | 0  | 0  | 0  | 0  | 0  | 0  | 0 | 0 | 0              | 0 | 0 | 0 | 0   | 0     | 0        |       |
| 018h   | LRC         | Reserved       |    |    |    |    |    |    |    |    |    |    |    |    |    |    |              |    |    |    |    |    |    |   |   | LRCDAT[7:0]    |   |   |   |     |       |          |       |
|        | Reset Value |                |    |    |    |    |    |    |    |    |    |    |    |    |    |    |              |    |    |    |    |    |    |   |   | 0              | 0 | 0 | 0 | 0   | 0     | 0        | 0     |

### 15.4.2 CRC32 data register (CRC\_CRC32DAT)

Address offset: 0x00

Reset value: 0xFFFF FFFF

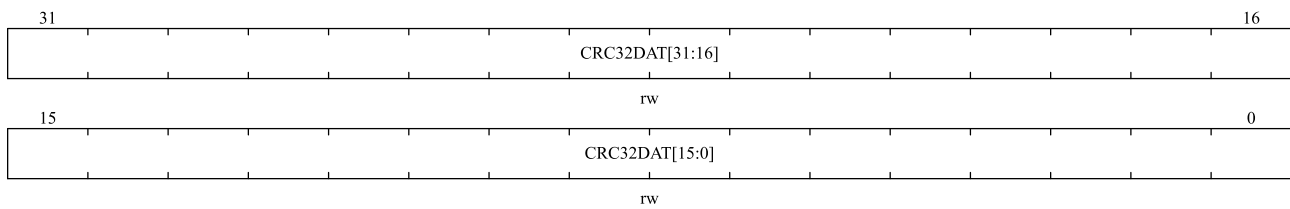

| Bit field | Name           | Description   |
|-----------|----------------|---|
| 31:0      | CRC32DAT[31:0] | The written data is the CRC value to be checked. The read data is the CRC calculation result. Only 32-bit operations are supported. |

### 15.4.3 CRC32 independent data register (CRC\_CRC32IDAT)

Address offset: 0x04

Reset value: 0x0000 0000

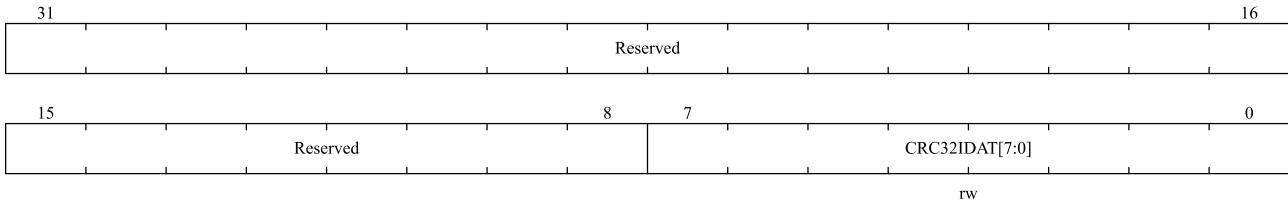

| Bit field | Name           | Description  |
|-----------|----------------|--|
| 31:8      | Reserved       | Reserved, the reset value must be maintained.  |
| 7:0       | CRC32IDAT[7:0] | Independent 8-bit data register.<br>General 8 bits data register. It is for temporary stored 1-byte data.<br>CRC_CRC32CTRL.RESET reset signal will not impact this register. |

Note: This register is not a part of CRC calculation and can be used to store any data.

#### 15.4.4 CRC32 control register (CRC\_CRC32CTRL)

Address offset: 0x08

Reset value: 0x0000 0000

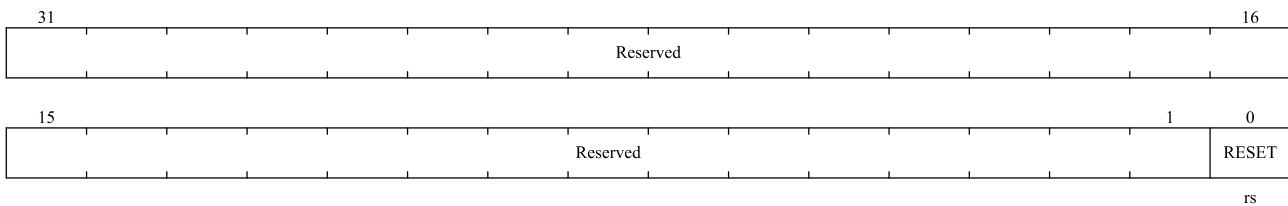

| Bit field | Name     | Description  |
|-----------|----------|--|
| 31:1      | Reserved | Reserved, the reset value must be maintained.  |
| 0         | RESET    | RESET signal.<br>It can reset CRC32 module and set data register to be 0xFFFF_FFFF. This reset can only write 1, and hardware will clear to 0 automatically. |

#### 15.4.5 CRC16 control register (CRC\_CRC16CTRL)

Address offset: 0x0C

Reset value: 0x0000 0000

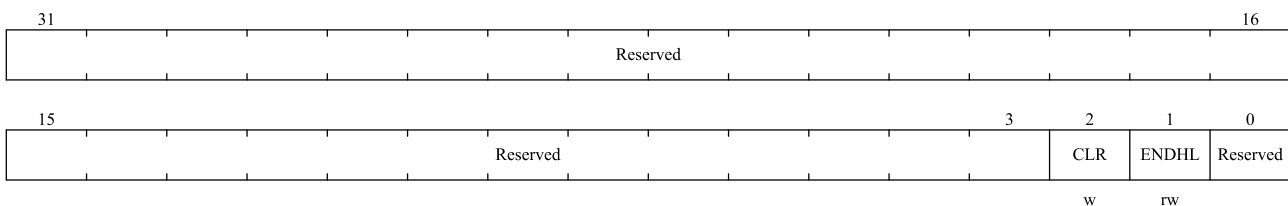

| Bit field | Name     | Description                                   |
|-----------|----------|---|
| 31:3      | Reserved | Reserved, the reset value must be maintained. |

| Bit field | Name     | Description   |
|-----------|----------|---|
| 2         | CLR      | Clear CRC16 results.<br>0: Not clear.<br>1: Clear to default value 0x0000. Set this bit to 1 will only maintain 1 clock cycle, hardware will clear automatically. (Software read always 0). |
| 1         | ENDHL    | Data to be verified start to calculate from MSB or LSB(configured endian).<br>0: From MSB to LSB<br>1: From LSB to MSB<br>This bit is only for data to be verified.                         |
| 0         | Reserved | Reserved, the reset value must be maintained.   |

Note: 8-bits, 16-bits and 32-bits operations are supported.

### 15.4.6 CRC16 input data register (CRC\_CRC16DAT)

Address offset: 0x10

Reset value: 0x0000 0000

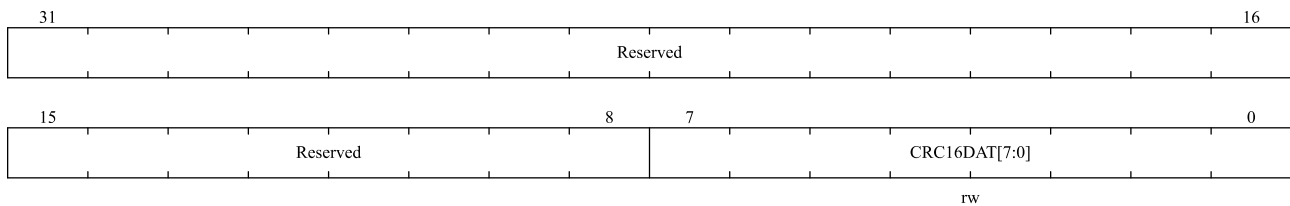

| Bit field | Name          | Description                                   |
|-----------|---------------|---|
| 31:8      | Reserved      | Reserved, the reset value must be maintained. |
| 7:0       | CRC16DAT[7:0] | Data to be verified.                          |

Note: 8-bits, 16-bits and 32-bits operations are supported.

### 15.4.7 CRC cyclic redundancy check code register (CRC\_CRC16D)

Address offset: 0x14

Reset value: 0x0000 0000

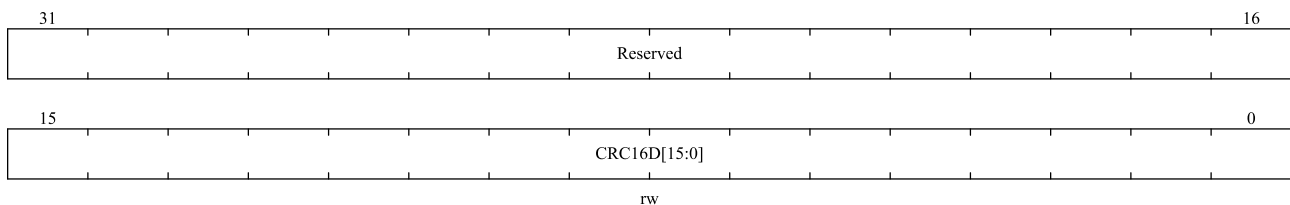

| Bit field | Name         | Description   |
|-----------|--------------|---|
| 31:16     | Reserved     | Reserved, the reset value must be maintained.   |
| 15:0      | CRC16D[15:0] | 16-bit value of cyclic redundancy result data.<br>Every time the software writes the CRC16DAT register, the 16-bit calculated data from |

| Bit field | Name | Description                        |
|-----------|------|------------------------------------|
|           |      | CRC16 is updated in this register. |

*Note: 8-bits, 16-bits and 32-bits operations are supported (8-bit operations must be performed twice in a row to ensure that 16-bit initial values are configured properly)*

### 15.4.8 LRC result register (CRC\_LRC)

Address offset: 0x18

Reset value: 0x0000 0000

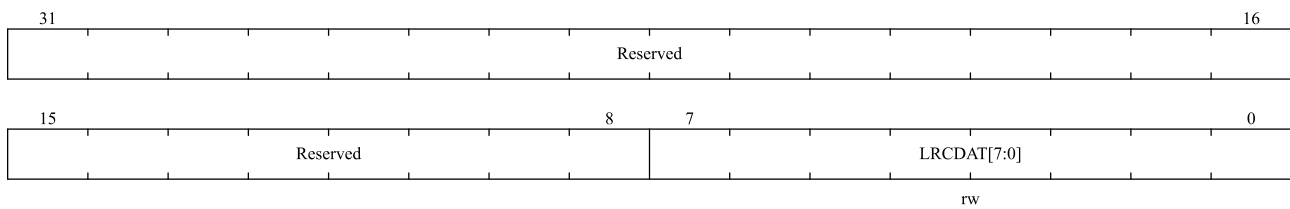

| Bit field | Name        | Description   |
|-----------|-------------|---|
| 31:8      | Reserved    | Reserved, the reset value must be maintained.   |
| 7:0       | LRCDAT[7:0] | LRC check value register.<br>Software need to write initial value before use. And then each writing data to CRC_CRC16DAT will be XOR with CRC_LCR register value. The result will be stored in CRC_LRC. Software read the result. It should be cleared before next use. |

## 16 Independent watchdog (IWDG)

### 16.1 Introduction

The N32G45x has built-in independent watchdog (IWDG) and window watchdog (WWDG) timers to solve the problems caused by software errors. Watchdog timer is very flexible to use, which improves the security of the system and the accuracy of timing control.

Independent Watchdog (IWDG) is driving by Low-speed internal clock (LSI clock) running at 40 KHz, which will still running event dead loop or MCU stuck is happening. This can provide higher safety level, timing accuracy and flexibility of watchdog. It can reset and resolve system malfunctions due to software failure. The IWDG is best suited for applications that require the watchdog to run as a totally independent process outside the main application, but have lower timing accuracy constraints.

When the power control register PWR\_CTRL2.IWDGRSTEN bit is '1' and the IWDG counter reaches 0, a system reset will be generated (if this bit is '0', the IWDG will count but not reset). When the PWR\_CTRL2.IWDGRSTEN bit is '1' and the IWDG counter reaches 0, it can wake up low power consumption (if this bit is '0', IWDG will count and reset but can only wake up SLEEP/STOP0, not STOP2/STANDBY).

*Note: This chapter is based on the system default IWDGRSTEN=1, IWDGWPEN=1 discussion..*

### 16.2 Main features

- Independent 12-bit down-counter
- RC oscillator provides independent clock source, which can also operate in SLEEP, STOP0, STOP2 and STANDBY mode.
- Reset and low-power wake-up can be matched.
- A system reset occurs when the down counter reaches 0x0000 (if watchdog activated).

## 16.3 Functional description

Figure 16-1 Functional block diagram of the independent watchdog module

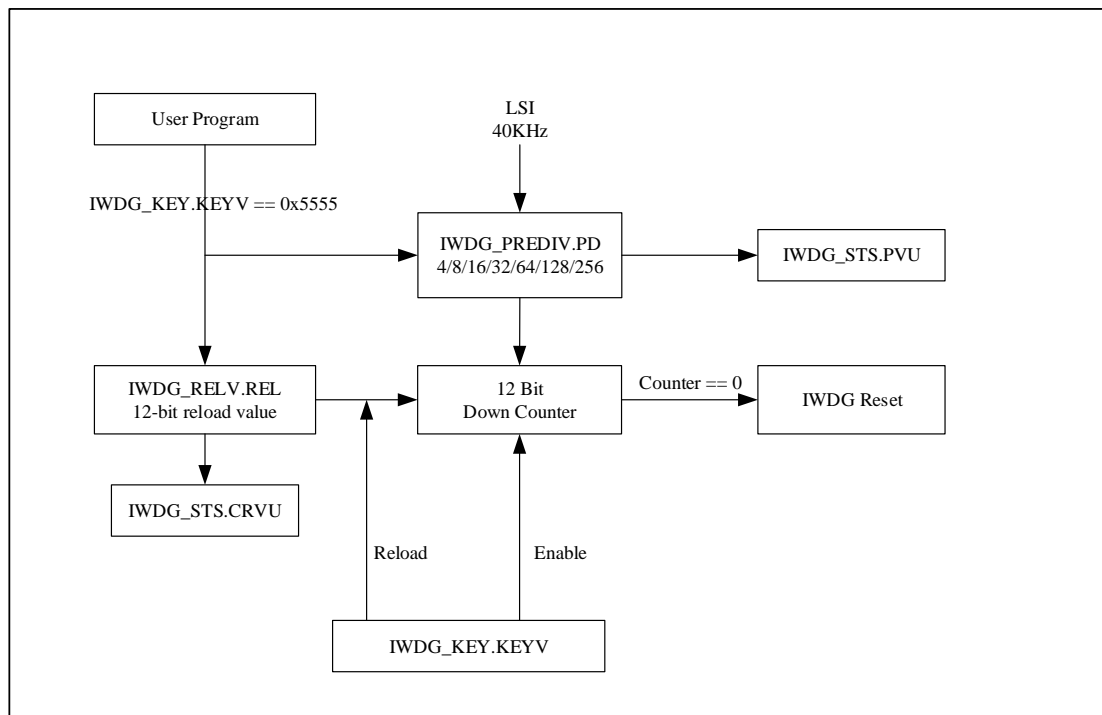

*Note: Watchdog function is in  $V_{DD}$  power supply area, and it can still work normally in SLEEP, STOP0, STOP2 and STANDBY modes.*

To enable IWDG, we need to write 0xCCCC to IWDG\_KEY.KEYV[15:0] bits. Counter starts counting down from reset value (0xFFFF). When counter count to 0x000, it generates a reset signal (IWDG\_RESET) to MCU. Other than that, as long as 0xAAAA (reload request) is write to IWDG\_KEY.KEYV[15:0] bits before reset, the counter value is set to the reload value in the IWDG\_RELV.REL[11:0] bits and prevents the watchdog from resetting the entire device.

If the "hardware watchdog timer" function is enabled through the selection byte, the watchdog will automatically start running after the system is powered on and will generate a system reset, unless the software reloads the counter before it reaches '0'.

### 16.3.1 Register access protection

IWDG\_PREDIV and IWDG\_RELV register are write protected. To modify the value of those two register, user needs to write 0x5555 to IWDG\_KEY.KEYV[15:0] bits. Writing other value enables write protections again. IWDG\_STS.PVU indicates whether the pre-scaler value update is on going. IWDG\_STS.CRVU indicates whether the IWDG is updating the reload value. The hardware sets the IWDG\_STS.PVU bit and/or IWDG\_STS.CRVU bit when the pre-scaler value and/or reload value is updating. After the pre-scaler value and/or reload value update is complete, the hardware clears the IWDG\_STS.PVU bit and/or IWDG\_STS.CRVU bit.

The reload operation (IWDG\_KEY.KEYV[15:0] configured with value of 0xAAAA) will also cause the registers to become write protected again.

## 16.3.2 Debug mode

In debug mode (Cortex-M4 core stops), IWDG counter will either continue to work normally or stops, depending on `DBG_CTRL.IWDG_STOP` bit in debug module. If this bit is set to '1', the counter stops. The counter works normally when the bit is '0'. See the chapter on debugging module for details 29.3.2.

## 16.4 User interface

IWDG module user interface contains 4 registers: Key Register (`IWDG_KEY`), Pre-scale Register (`IWDG_PREDIV`), Reload Register (`IWDG_RELV`) and Status Register (`IWDG_STS`).

### 16.4.1 Operate flow

When IWDG is enable from reset from software (write `0xAAAA` to `IWDG_KEY.KEYV[15:0]` bits) or hardware (clear `WDG_SW` bit). It starts counting down from `0xFFF`. Down counting gap is determined by pre-scale LSI clock. Once the counter is reloaded, each new round will start from the value in `IWDG_RELV.REL[11:0]` instead of `0xFFF`.

When program is running normally, software needs to feed IWDG before counter reaches 0 and start a new round of down counting. When counter reach 0, this indicates program malfunction. IWDG generates reset signal under this circumstance.

If user wants to configure IWDG pre-scale and reload value register, it needs to write `0x5555` to `IWDG_KEY.KEYV[15:0]` first. Then confirm `IWDG_STS.CRVU` bit and `IWDG_STS.PVU` bit. `IWDG_STS.CRVU` bit indicates reload value update is ongoing, `IWDG_STS.PVU` indicates Pre-scale divider ratio is updating. Only when those two bit are 0 then user can update corresponding value. When update is on-going, hardware sets corresponding bit to 1. At this time, reading `IWDG_PREDIV.PD[2:0]` or `IWDG_RELV.REL[11:0]` is invalid since data needs sync to LSI clock domain. The value read from `IWDG_PREDIV.PD[2:0]` or `IWDG_RELV.REL[11:0]` will be valid after hardware clears the `IWDG_STS.PVU` bit or `IWDG_STS.CRVU` bit.

If the application uses more than one reload value or pre-scaler value, it must wait until the `IWDG_STS.CRVU` bit is reset before changing the reload value, the same as changing the pre-scaler value. However, after updating the pre-scale and/or the reload value, it is not necessary to wait until `IWDG_STS.CRVU` bit or `IWDG_STS.PVU` bit are reset before continuing code execution (even in case of low-power mode entry, the write operation is taken into account and will complete).

Pre-scale register and reload register controls the time that generates reset, as shown in Table 16-1.

Table 16-1 IWDG counting maximum and minimum reset time

| Pre-scale factor | PD[2:0] | Minimum (ms)<br>RL[11:0]=0 | Maximum (ms)<br>RL[11:0]=0xFFF |
|------------------|---------|----------------------------|--------------------------------|
| /4               | 000     | 0.1                        | 409.6                          |
| /8               | 001     | 0.2                        | 819.2                          |
| /16              | 010     | 0.4                        | 1638.4                         |
| /32              | 011     | 0.8                        | 3276.8                         |
| /64              | 100     | 1.6                        | 6553.6                         |
| /128             | 101     | 3.2                        | 13107.2                        |
| /256             | 11x     | 6.4                        | 26214.4                        |

## 16.4.2 IWDG configuration flow

Software flow:

1. Write 0x5555 to IWDG\_KEY.KEYV[15:0] bits to enable write access of IWDG\_PREDIV and IWDG\_RELV registers.
2. Check IWDG\_STS.PVU bit or IWDG\_STS.CRVU bit, if they are 0, continue next step.
3. Configure IWDG\_PREDIV.PD[2:0] bits to select pre-scale value.
4. Configure IWDG\_RELV.REL[11:0] bits reload value.
5. Writing 0xAAAA to IWDG\_KEY.KEYV[15:0] bits to upload counter with reload value.
6. Enable watchdog by software or hardware writing 0xCCCC to IWDG\_KEY.KEYV[15:0] bits.

If user wants change pre-scale and reload value, repeat step 1~5. If not, just feed the dog with step 5.

## 16.5 IWDG registers

### 16.5.1 IWDG register overview

Table 16-2 IWDG register overview

| Offset | Register    | 31       | 30 | 29 | 28 | 27 | 26 | 25 | 24 | 23 | 22 | 21 | 20 | 19 | 18 | 17 | 16 | 15         | 14 | 13 | 12 | 11 | 10 | 9 | 8 | 7       | 6   | 5 | 4 | 3 | 2 | 1 | 0 |   |   |   |   |   |   |   |   |   |   |   |   |   |   |
|--------|-------------|----------|----|----|----|----|----|----|----|----|----|----|----|----|----|----|----|------------|----|----|----|----|----|---|---|---------|-----|---|---|---|---|---|---|---|---|---|---|---|---|---|---|---|---|---|---|---|---|
| 0x00   | IWDG_KEY    | Reserved |    |    |    |    |    |    |    |    |    |    |    |    |    |    |    | KEYV[15:0] |    |    |    |    |    |   |   |         |     |   |   |   |   |   |   |   |   |   |   |   |   |   |   |   |   |   |   |   |   |
|        | Reset value |          |    |    |    |    |    |    |    |    |    |    |    |    |    |    |    | 0          | 0  | 0  | 0  | 0  | 0  | 0 | 0 | 0       | 0   | 0 | 0 | 0 | 0 | 0 | 0 | 0 | 0 | 0 | 0 | 0 | 0 | 0 | 0 | 0 | 0 | 0 | 0 | 0 | 0 |
| 0x04   | IWDG_PREDIV | Reserved |    |    |    |    |    |    |    |    |    |    |    |    |    |    |    |            |    |    |    |    |    |   |   | PD[2:0] |     |   |   |   |   |   |   |   |   |   |   |   |   |   |   |   |   |   |   |   |   |
|        | Reset value |          |    |    |    |    |    |    |    |    |    |    |    |    |    |    |    |            |    |    |    |    |    |   |   | 0       | 0   | 0 |   |   |   |   |   |   |   |   |   |   |   |   |   |   |   |   |   |   |   |
| 0x08   | IWDG_RELV   | Reserved |    |    |    |    |    |    |    |    |    |    |    |    |    |    |    | REL[11:0]  |    |    |    |    |    |   |   |         |     |   |   |   |   |   |   |   |   |   |   |   |   |   |   |   |   |   |   |   |   |
|        | Reset value |          |    |    |    |    |    |    |    |    |    |    |    |    |    |    |    | 1          | 1  | 1  | 1  | 1  | 1  | 1 | 1 | 1       | 1   | 1 | 1 | 1 | 1 | 1 | 1 | 1 | 1 | 1 | 1 | 1 | 1 | 1 | 1 | 1 | 1 | 1 | 1 | 1 | 1 |
| 0x0C   | IWDG_STS    | Reserved |    |    |    |    |    |    |    |    |    |    |    |    |    |    |    |            |    |    |    |    |    |   |   | CRVU    | PVU |   |   |   |   |   |   |   |   |   |   |   |   |   |   |   |   |   |   |   |   |
|        | Reset value |          |    |    |    |    |    |    |    |    |    |    |    |    |    |    |    |            |    |    |    |    |    |   |   | 0       | 0   |   |   |   |   |   |   |   |   |   |   |   |   |   |   |   |   |   |   |   |   |

### 16.5.2 IWDG key register (IWDG\_KEY)

Address offset: 0x00

Reset value: 0x00000000

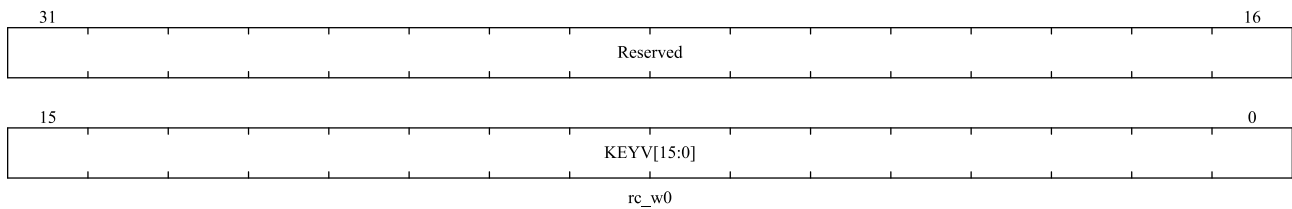

| Bit field | Name       | Description  |
|-----------|------------|--|
| 31:16     | Reserved   | Reserved, the reset value must be maintained.  |
| 15:0      | KEYV[15:0] | Key value register: only certain value will serve particular function<br>0xCCCC: Start watch dog counter, does not have any effect if hardware watchdog is enable, (if hardware watchdog is selected, it is not limited by this command word)<br>0xAAAA: Reload counter with REL value in IWDG_RELV register to prevent reset.<br>0x5555: Disable write protection of IWDG_PREDIV and IWDG_RELV register |

### 16.5.3 IWDG pre-scaler register (IWDG\_PREDIV)

Address offset: 0x04

Reset value: 0x00000000

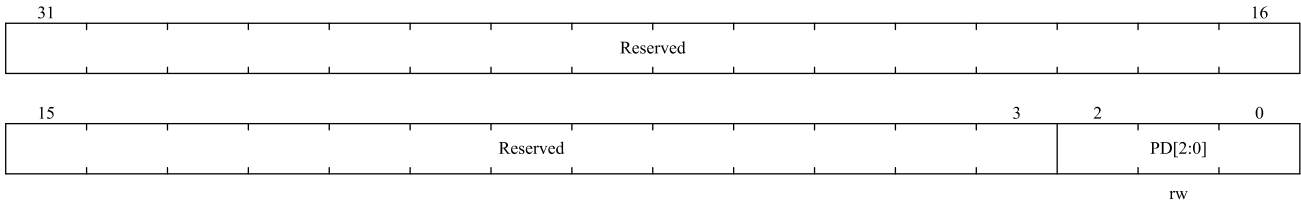

| Bit field | Name     | Description   |
|-----------|----------|---|
| 31:3      | Reserved | Reserved, the reset value must be maintained.   |
| 2:0       | PD[2:0]  | Pre-frequency division factor<br>Pre-scaler divider: with write access protection when IWDG_KEY.KEYV[15:0] is not 0x5555. The IWDG_STS.PVU bit must be 0 otherwise PD [2:0] value cannot be changed. Divide number is as follow:<br>000: divider /4<br>001: divider /8<br>010: divider /16<br>011: divider /32<br>100: divider /64<br>101: divider /128<br>Other : divider /256<br><i>Note: Reading this register will return the pre-divided value from the VDD voltage domain. If a write operation is in progress, the read-back value may be invalid. Therefore, the read value is valid only when the IWDG_STS.PVU bit is '0'.</i> |

### 16.5.4 IWDG reload register (IWDG\_RELV)

Address offset: 0x08

Reset value: 0x00000FFF

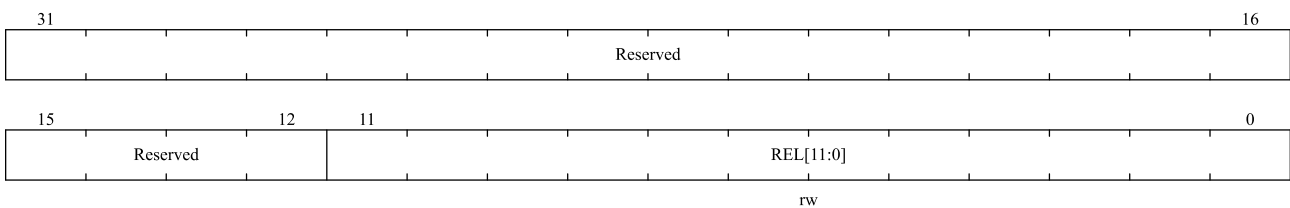

| Bit field | Name     | Description                                   |
|-----------|----------|---|
| 31:12     | Reserved | Reserved, the reset value must be maintained. |

| Bit field | Name      | Description   |
|-----------|-----------|---|
| 11:0      | REL[11:0] | <p>Watchdog counter reload value.</p> <p>With write protection. Defines the reload value of the watchdog counter, which is loaded to the counter every time 0xAAAA is written to IWDG_KEY.KEYV[15:0] bits. The counter then starts to count down from this value. The watchdog timeout period can be calculated from this reloading value and the clock pre-scaler value, refer to Table 16-1.</p> <p>This register can only be modified when the IWDG_STS.CRVU bit is '0'.</p> <p><i>Note: Reading this register will return the reload value from the VDD voltage domain. If a write operation is in progress, the read-back value may be invalid. Therefore, the read value is valid only when the IWDG_STS.CRVU bit is '0'.</i></p> |

### 16.5.5 IWDG status register (IWDG\_STS)

Address offset: 0x0C

Reset value: 0x00000000

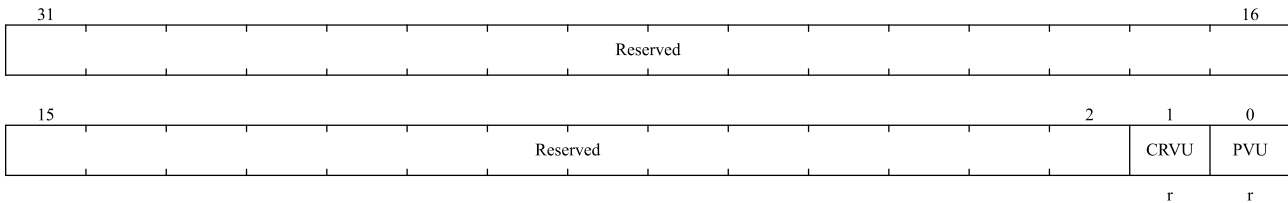

| Bit field | Name     | Description   |
|-----------|----------|---|
| 31:2      | Reserved | Reserved, the reset value must be maintained.   |
| 1         | CRVU     | <p>Watchdog reload value update</p> <p>Reload Value Update: this bit indicates an update of reload value is ongoing. Set by hardware and clear by hardware. Software can only try to change IWDG_RELV.REL[11:0] value when IWDG_KEY.KEYV[15:0] bits' value is 0x5555 and this bit is 0.</p>             |
| 0         | PVU      | <p>Watchdog pre-scaler value update</p> <p>Pre-scaler Value Update: this bit indicates an update of pre-scaler value is ongoing. Set by hardware and clear by hardware. Software can only try to change IWDG_PREDIV.PD[2:0] value when IWDG_KEY.KEYV[15:0] bits' value is 0x5555 and this bit is 0.</p> |

## 17 Window watchdog (WWDG)

### 17.1 Introduction

The clock of the window watchdog (WWDG) is obtained by dividing the APB1 clock frequency by 4096, and whether the program operation is abnormal is detected through the configuration of the time window. Therefore, WWDG is suitable for precise timing, and is often used to monitor software failures caused by external disturbances or unforeseen logic conditions that cause an application to deviate from its normal operating sequence. A system reset occurs when the WWDG down counter is refreshed before reaching the window register value or after the WWDG\_CTRL.T6 bit becomes 0.

### 17.2 Main features

- 7-bit independent running down counter programmable
- After WWDG is enabled, a reset occurs under the following conditions
  - ◆ The value of the decremented counter is less than 0x40.
  - ◆ When the decremented counter value is greater than the value of the window register, it is reloaded.
- Early wake-up interrupt: If the watchdog is started and the interrupt is enabled, wake-up interrupt (WWDG\_CFG.EWINT) will be generated when the count value reaches 0x40.

### 17.3 Function description

If the watchdog is activated (the WWDG\_CTRL.ACTB bit), when the 7-bit (WWDG\_CTRL.T[6:0]) down-counter reaches 0x3F (WWDG\_CTRL.T6 bit is cleared), or the software reloads the counter when the counter value is greater than the value of the window register, a system reset will be generated. In order to avoid system reset, the software must periodically refresh the counter value in the window during normal operation.

Figure 17-1 Watchdog block diagram

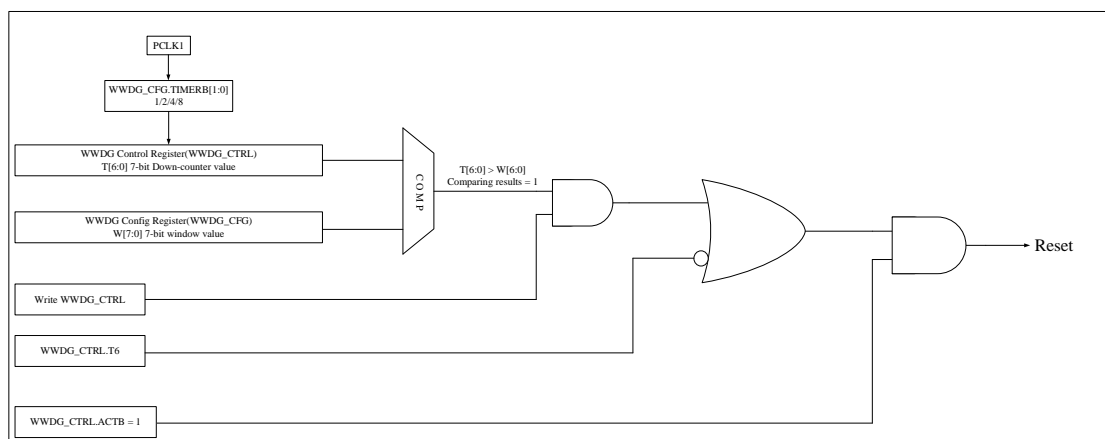

Set the WWDG\_CTRL.ACTB bit to enable the watchdog, and thereafter, the WWDG will remain on until reset occurs. The 7-bit down-counter runs independently, and the counter keeps counting down whether WWDG is enabled or not. Therefore, before enabling the watchdog, you need to set WWDG\_CTRL.T[6] bit to 1, preventing reset right after enable. The pre-scaler value set by the clock APB1 and WWDG\_CFG.TIMERB[1:0] bits determine the decrement speed of the counter. WWDG\_CFG.W[6:0] bits set the upper limit of the window.

When the down-counter is refreshed before reaching the window register value or after WWDG\_CTRL.T6 bit becomes 0, a system reset will be generated. Figure 17-2 describes the working process of the window register.

Set the WWDG\_CFG.EWINT bit to enable early wake-up interrupt. When the count-down counter reaches 0x40, an interrupt will be generated. You can analyze the cause of software failure or save important data in the corresponding interrupt service routine (ISR), and reload the counter to prevent WWDG from resetting. Write '0' to the WWDG\_STS.EWINTF bit to clear the interrupt.

## 17.4 Timing for refresh watchdog and interrupt generation

Figure 17-2 Refresh window and interrupt timing of WWDG

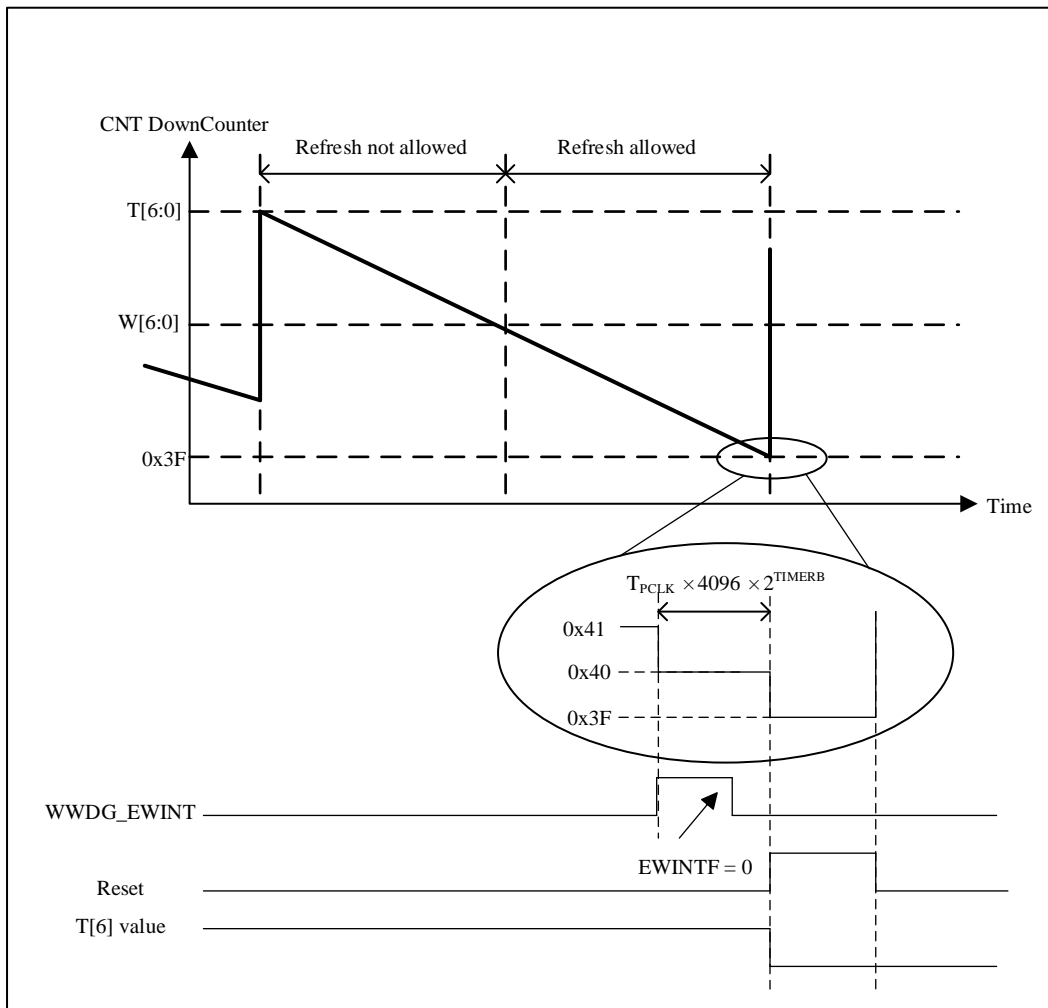

Watchdog refreshing window is between WWDG\_CFG.W[6:0] value (maximum value 0x7F) and 0x3F, refresh outside this window will generate reset request to MCU. Counter count down from 0x7F to 0x3F using scaled APB1 clock, the maximum counting time and minimum counting time is shown in Table 17-1 (assuming APB1 clock 36 MHz) with calculate equation:

$$T_{WWDG} = T_{PCLK1} \times 4096 \times 2^{TIMERB} \times (T[5:0] + 1)$$

In which:

$T_{\text{WWDG}}$ : WWDG timeout

$T_{\text{PCLK1}}$ : APB1 clock interval in ms

Minimum-maximum timeout value at PCLK1 = 36MHz

Table 17-1 Maximum and minimum counting time of WWDG

| TIMERB | Maximum counting (ms) | Minimum counting (ms) |
|--------|-----------------------|-----------------------|
| 0      | 7.28                  | 0.113                 |
| 1      | 14.56                 | 0.227                 |
| 2      | 29.12                 | 0.455                 |
| 3      | 58.25                 | 0.910                 |

## 17.5 Debug mode

In debug mode (Cortex-M4 core stops), WWDG counter will either continue to work normally or stops, depending on DBG\_CTRL.WWDG\_STOP bit in debug module. If this bit is set to '1', the counter stops. The counter works normally when the bit is '0'. See the chapter on debugging module for details 29.3.2.

## 17.6 User interface

### 17.6.1 WWDG configuration flow

- 1) Configure RCC\_APB1PCLKEN.WWDGEN[11] bit to enable the clock of WWDG module;
- 2) Software setting WWDG\_CFG.TIMERB[8:7] bits to configure pre-scale factor for WWDG.
- 3) Software configure WWDG\_CTRL.T[6:0] bits, setting starting value of counter. Need to set WWDG\_CTRL.T[6] bit to 1, preventing reset right after enable.
- 4) Configure WWDG\_CFG.W[6:0] bits to configure upper boundary window value;
- 5) Setting WWDG\_CTRL.ACTB[7] bit to enable WWDG;
- 6) Software operates WWDG\_STS.EWINTF[0] bit to clear wake-up interrupt flag;
- 7) Configure WWDG\_CFG.EWINT[9] bit to enable early wake-up interrupt.

## 17.7 WWDG registers

### 17.7.1 WWDG register overview

Table 17-2 WWDG register overview

| Offset | Register    | 31       | 30 | 29 | 28 | 27 | 26 | 25 | 24 | 23 | 22 | 21 | 20 | 19 | 18 | 17 | 16 | 15 | 14 | 13 | 12 | 11 | 10 | 9     | 8            | 7      | 6      | 5      | 4 | 3 | 2 | 1 | 0 |
|--------|-------------|----------|----|----|----|----|----|----|----|----|----|----|----|----|----|----|----|----|----|----|----|----|----|-------|--------------|--------|--------|--------|---|---|---|---|---|
| 000h   | WWDG_CTRL   | Reserved |    |    |    |    |    |    |    |    |    |    |    |    |    |    |    |    |    |    |    |    |    |       |              | ACTB   | T[6:0] |        |   |   |   |   |   |
|        | Reset Value |          |    |    |    |    |    |    |    |    |    |    |    |    |    |    |    |    |    |    |    |    |    |       |              | 0      | 1      | 1      | 1 | 1 | 1 | 1 | 1 |
| 004h   | WWDG_CFG    | Reserved |    |    |    |    |    |    |    |    |    |    |    |    |    |    |    |    |    |    |    |    |    | EWINT | TIMERB [1:0] | W[6:0] |        |        |   |   |   |   |   |
|        | Reset Value |          |    |    |    |    |    |    |    |    |    |    |    |    |    |    |    |    |    |    |    |    |    | 0     | 0            | 0      | 1      | 1      | 1 | 1 | 1 | 1 | 1 |
| 008h   | WWDG_STS    | Reserved |    |    |    |    |    |    |    |    |    |    |    |    |    |    |    |    |    |    |    |    |    |       |              |        |        | EWINTF |   |   |   |   |   |
|        | Reset Value |          |    |    |    |    |    |    |    |    |    |    |    |    |    |    |    |    |    |    |    |    |    |       |              |        |        | 0      |   |   |   |   |   |

### 17.7.2 WWDG control register (WWDG\_CTRL)

Address offset : 0x00

Reset value : 0x0000007F

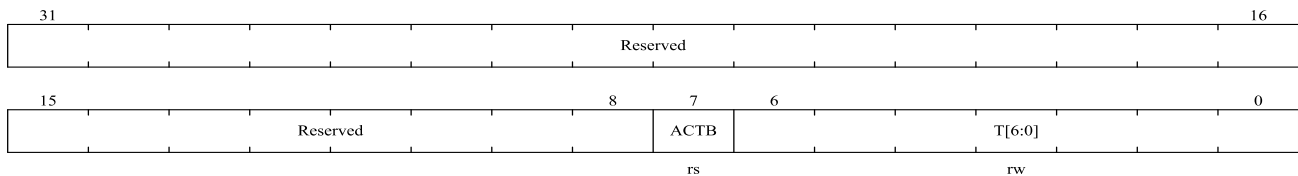

| Bit field | Name     | Description  |
|-----------|----------|--|
| 31:8      | Reserved | Reserved, the reset value must be maintained.  |
| 7         | ACTB     | Activation bit<br>When ACTB=1, the watchdog can generate a reset. This bit is set by software and only cleared by hardware after a reset. When ACTB = 1, the watchdog can generate a reset.<br>0: Disable watchdog<br>1: Enable watchdog |
| 6:0       | T[13:0]  | These bits contain the value of the watchdog counter. It is decremented every $(4096 \times 2^{\text{TIMERB}})$ PCLK1 cycles. A reset is produced when it rolls over from 0x40 to 0x3F (T6 becomes cleared).                             |

### 17.7.3 WWDG config register (WWDG\_CFG)

Address offset: 0x04

Reset value : 0x0000007F

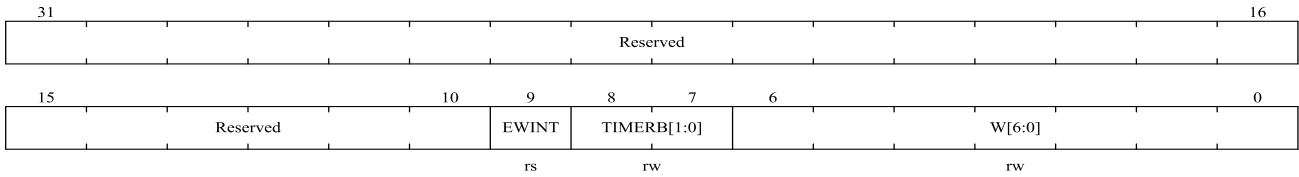

| Bit field | Name        | Description  |
|-----------|-------------|--|
| 31:10     | Reserved    | Reserved, the reset value must be maintained.  |
| 9         | EWINT       | Early wake-up interrupt<br>When set, an interrupt occurs whenever the counter reaches the value 0x40. This interrupt is only cleared by hardware after a reset.  |
| 8:7       | TIMERB[1:0] | Timer base.<br>The time base of the pre-scaler can be modified as follows:<br>00: CK Counter Clock (PCLK1 div 4096) div 1<br>01: CK Counter Clock (PCLK1 div 4096) div 2<br>10: CK Counter Clock (PCLK1 div 4096) div 4<br>11: CK Counter Clock (PCLK1 div 4096) div 8 |
| 6:0       | W[6:0]      | 7-bit window value<br>These bits contain the window value to be compared to the down counter.  |

### 17.7.4 WWDG status register (WWDG\_STS)

Address offset: 0x08

Reset value : 0x0000

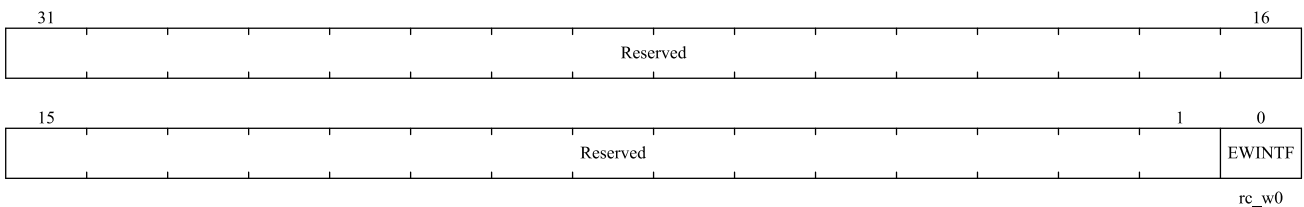

| Bit field | Name     | Description   |
|-----------|----------|---|
| 31:1      | Reserved | Reserved, the reset value must be maintained.   |
| 0         | EWINTF   | Early wake-up interrupt flag<br>This bit is set by hardware when the counter has reached the value 0x40. It must be cleared by software by writing '0'. A write of '1' has no effect. This bit is also set if the interrupt is not enabled. |

## 18 SDIO Interface (SDIO)

### 18.1 Main features of SDIO

SDIO interface defines SD card, SD I/O card, Multimedia Card (MMC) host interface. It provides data transfer between AHB peripheral bus and SD memory card, SDIO card, Multimedia Card (MMC) and CE-ATA devices. Among them, the supported multimedia card system specifications are published by the MMCA technical committee and can be obtained on the website of the Multimedia Card Association ([www.mmca.org](http://www.mmca.org)), and the supported CE-ATA system specifications can be found in the CE-ATA working group. Available on the website ([www.ce-ata.org](http://www.ce-ata.org)), supported SD memory cards and SD I/O card system specifications are available through the SD Card Association website ([www.sdcard.org](http://www.sdcard.org)).

#### Main features of SDIO are as follows:

- SD card: fully compatible with SD memory card specification version 2.0.
- SD I/O: Fully compatible with SD I/O card specification version 2.0, there are two different data bus modes: 1-bit (default) and 4-bit.
- MMC: Fully compatible with Multimedia Card System Specification Version 4.2 and earlier versions. There are three different data bus modes: 1-bit (default), 4-bit and 8-bit.
- CE-ATA: fully compatible with CE-ATA digital protocol version 1.1, fully supports CE-ATA function.
- Up to 48MHz data transfer rate in 8-bit data bus mode.
- Support interrupt and DMA request.
- Supports data and command output enable signals for controlling external bidirectional drivers.

#### Notice:

1. SDIO has no SPI compatible communication mode.
2. In version 2.11 of the Multimedia Card System Specification, it is defined that the SD memory card protocol only supports the I/O part of the SD card or composite card in I/O mode, and does not support many required commands in the SD storage device, such as erasing etc. some commands don't work in SDI/O devices, so SDIO doesn't support these commands either. In addition, some commands are different in SD memory card and SD I/O card, and SDIO does not support these commands.

SDIO supports only one SD/SDIO/MMC 4.2 card or CE-ATA device at a time, but can support multiple MMC version 4.1 or earlier cards.

### 18.2 SDIO bus topology

Communication on the SDIO bus is achieved by transferring commands and data. After power-on reset, the host must

initialize the card through a special message-based bus protocol. Each message is a command/response structure, additionally, some messages have data tokens. Each part of the message is described in detail as follows:

- **Command:** The command is serially transmitted on the CMD line and is a token to initiate an operation, sent from the host to the card
- **Response:** A response is serially transmitted on the CMD line, sent from the card to the host in response to a previously received command.
- **Data:** Data is transmitted through the data line. Data can be transferred from the card to the host or from the host to the card. The number of data lines used for data transfer can be 1 (SDIO\_DAT0), 4 (SDIO\_DAT[3:0]) or 8 (SDIO\_DAT[7:0]).

The structure of commands, responses and data blocks is described in the card functional description chapter. A data transfer is a bus operation. A normal operation always consists of a command and response. Additionally, some operations have a data token. There are other operations that include their information directly in the command or response structure. In this case, the operation has no data token.

There are two types of data transfer commands: block and stream. Data transmitted on SD/SDIO memory cards and CE-ATA devices is transmitted in the form of data blocks; data transmitted on MMC is transmitted in the form of data blocks or data streams;

Data streams and data block transfers are defined as follows:

- **Data flow:** The command initiates a continuous data flow, and the data transmission is terminated only when a stop command appears on the CMD signal line. This mode minimizes command overhead (only MMC is supported).
- **Data block:** The command successfully sends a data block followed by a CRC check. Read and write operations allow single or multiple block transfers. As with continuous read, a multi-block transfer is terminated when a stop command appears on the CMD signal line.

The basic operations on the SDIO bus are command/response operations, and this type of bus transaction passes their information directly in a command or response structure. In addition, some operations have data tokens. Data transfer between the card and the device is done through blocks. Each transmission type is shown in the following figure:

Figure 18-1 SDIO "No Response" and "No Data" operations

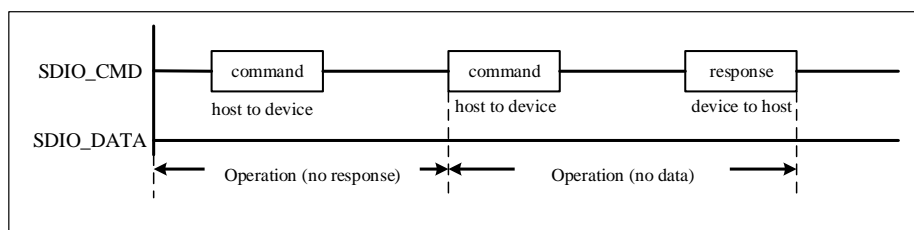

Figure 18-2 SDIO (multi) data block read operation

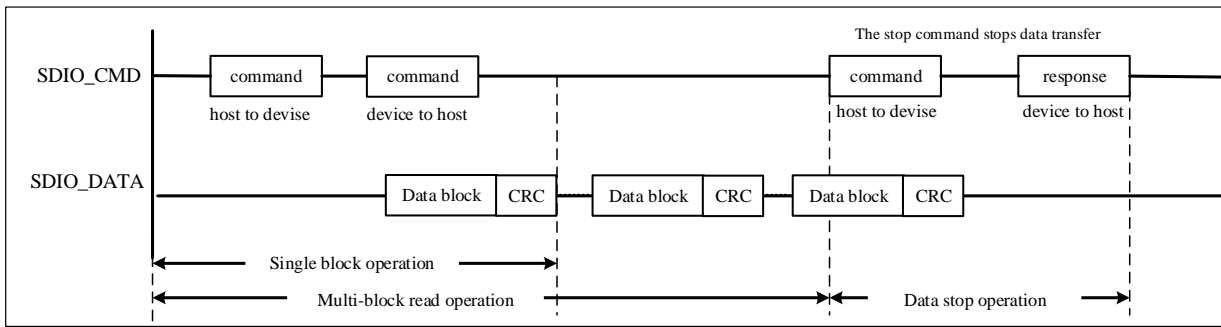
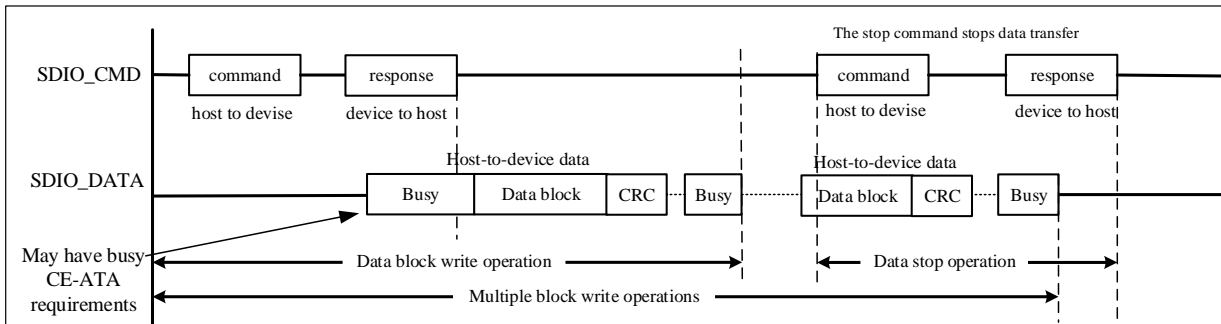

Figure 18-3 SDIO (multiple) data block write operation



Note: When there is a Busy signal, SDIO (SDIO\_DAT0 is pulled low) will not send any data.

Figure 18-4 SDIO continuous read operation

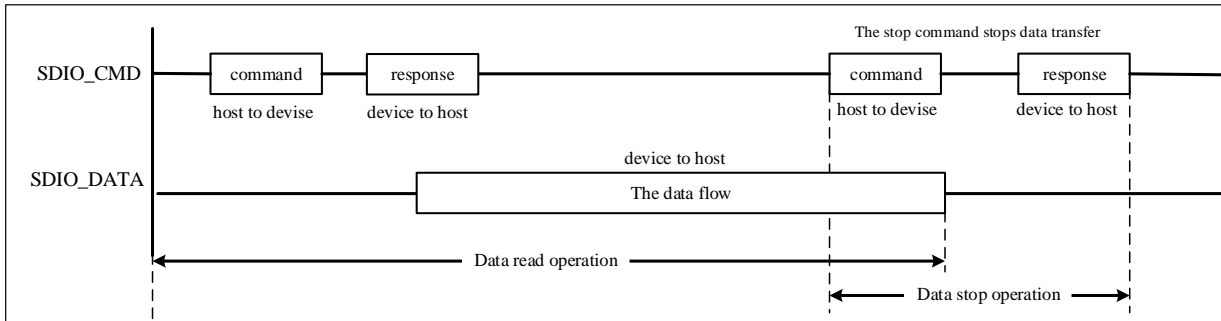
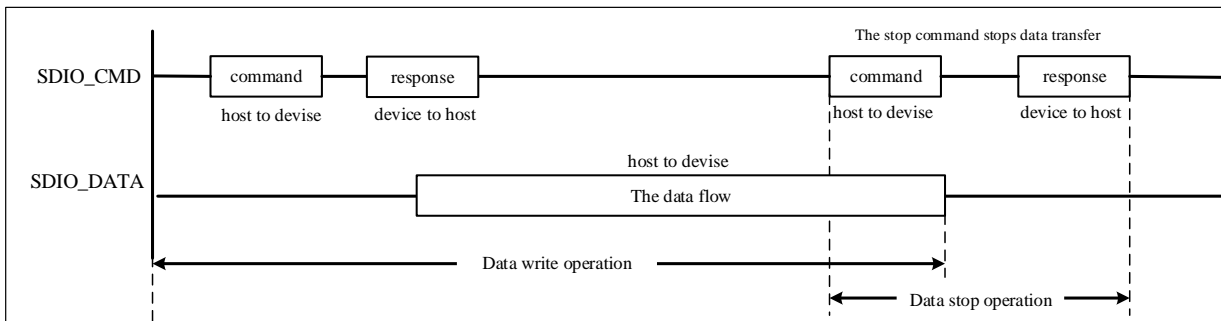

Figure 18-5 SDIO continuous write operation



## 18.3 SDIO function description

Figure 18-6 is a block diagram of SDIO structure:

- SDIO adapter: It consists of control unit, command unit and data unit. The control unit generates a clock signal, and the command unit and data unit manage the transmission of commands and data respectively, thereby realizing the related functions of the MMC/SD/SD I/O card. .
- AHB bus interface: used to operate the FIFO unit of the register control data transmission in the SDIO adapter module, and generate interrupt and DMA request signals.

Figure 18-6 SDIO block diagram

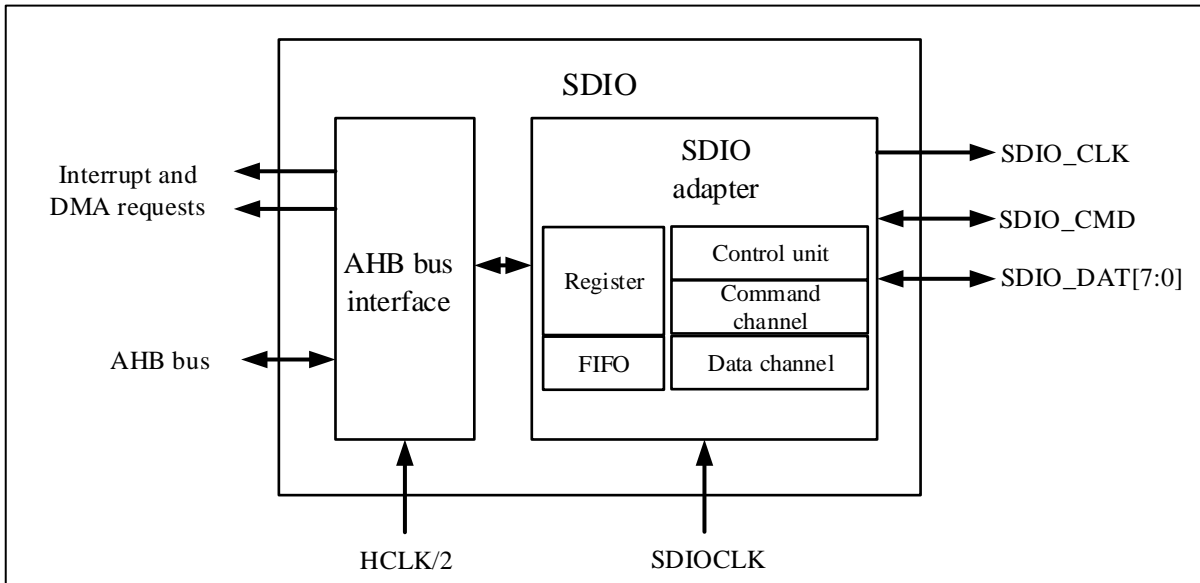

### 18.3.1 SDIO adapter

The following figure is a simplified block diagram of the SDIO adapter:

Figure 18-7 SDIO adapter

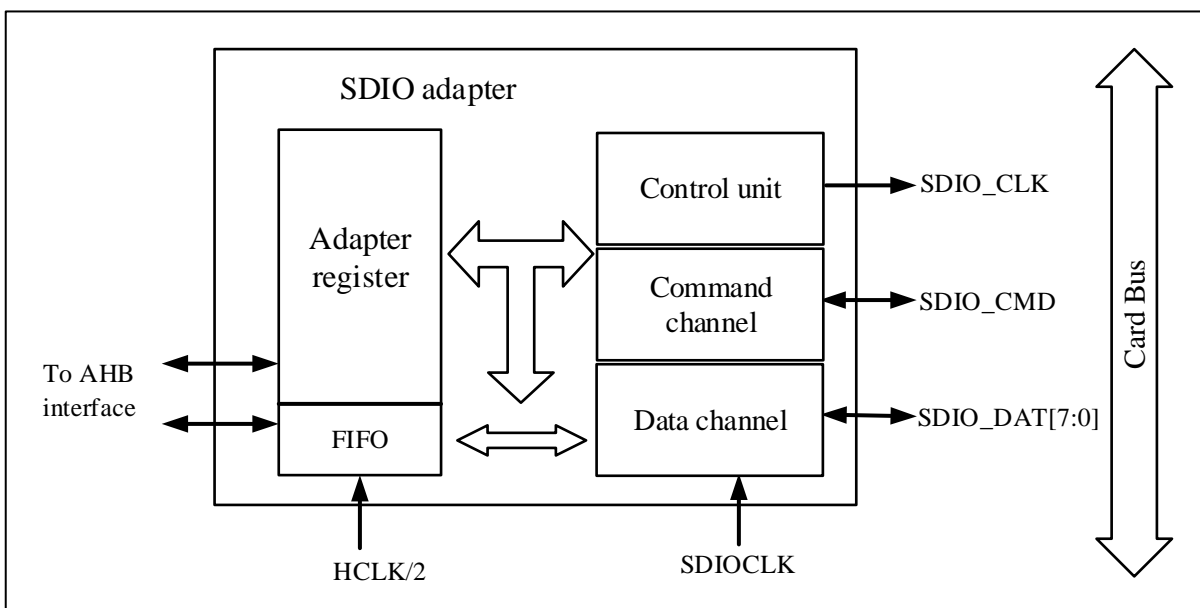

The HCLK/2 of the AHB bus is used as the clock of the adapter register and FIFO, and the SDIOCLK(equal to HCLK) is used as the clock of the control unit, command channel and data channel.

The SDIO adapter includes five parts: control unit, adapter register module, command unit, data unit and data FIFO. The signals output to the card bus are as follows:

- SDIO\_DAT[7:0]: The data signal line uses push-pull mode. By default, only SDIO\_DAT0 is used for data transfer after power-on or reset. The SDIO adapter can configure a wider data bus for data transfer after initializing the host, using DAT0-DAT3 or DAT0-DAT7 (only for MMC V4.2). Note that the protocol of MMC version V3.31 and previous versions only supports 1-bit data line (only SDIO\_DAT0 can be used). When an SD or SD I/O card is connected to the bus, SDIO\_DAT0 or SDIO\_DAT[3:0] can be used by the host to configure data transfers.
- SDIO\_CMD, two operating modes:
  - ◆ Open-drain mode for initialization (only for MMC version V3.31 or earlier)
  - ◆ Push-pull mode for command transfer (SD/SD I/O cards and MMC V4.2 also use push-pull drive during initialization)
- SDIO\_CLK: The clock provided to the card by the SDIO controller. One bit of command or data is sent directly on the command line (SDIO\_CMD) and all data lines per clock cycle. The variation range of the clock frequency of different cards is different, as follows:
  - ◆ MMC V3.31 protocol, optional clock frequency between 0MHz and 20MHz;
  - ◆ MMC V4.0/4.2 protocol, optional clock frequency between 0MHz and 48MHz;
  - ◆ SD or SD I/O card, optional clock frequency between 0MHz and 25MHz.

The following table is the MMC/SD/SD I/O card bus pin definition:

Table 18-1 MMC/SD/SD I/O Card bus pin definition

| Pin           | Direction     | Description  |
|---------------|---------------|--|
| SDIO_CLK      | Output        | MMC/SD/SDIO card clock, clock line from host to card                 |
| SDIO_CMD      | Bidirectional | MMC/SD/SDIO card command, bidirectional command/response signal line |
| SDIO_DAT[7:0] | Bidirectional | MMC/SD/SDIO card data, bidirectional data bus                        |

### 18.3.1.1 Adapter register block

The adapter register block contains all SDIO related registers.

### 18.3.1.2 Control unit

The control unit contains power management functions and clock management functions, which are used for the memory card identification, initialization, clock control etc.

Power management is controlled by the SDIO\_PWRCTRL register to achieve power down and power up. There are three power phases: power off, power up, and power on.

Configure the power saving mode by setting SDIO\_CLKCTRL.PWRCFG bit to turn off SDIO\_CLK when the bus is idle. When SDIO\_CLKCTRL.CLKBYP bit is 0, SDIO\_CLK is obtained by dividing the frequency of SDIOCLK; when SDIO\_CLKCTRL.CLKBYP bit is 1, SDIO\_CLK is directly SDIOCLK.

Hardware clock control is enabled by setting the HWCLKEN bit in the SDIO\_CLKCTRL register. This function is

used to avoid FIFO underflow and overflow errors. The hardware controls the switch of SDIO\_CLK according to whether the system bus is busy. When the FIFO cannot receive or transmit data, the host will turn off SDIO\_CLK and freeze the SDIO state machine to avoid related errors. Only the state machine can be frozen, but the AHB interface is still working. Therefore, the FIFO can be accessed through the AHB bus.

The clock management subunit generates and controls the SDIO\_CLK signal. SDIO\_CLK output supports: clock divider or clock bypass mode.

SDIO\_CLK clock not output in these three cases after reset, during power-off and power-on phases, or when power-saving mode is enabled and the card bus is idle (8 clock cycles after the command channel and data channel subunits enter the idle phase).

Figure 18-8 Control unit

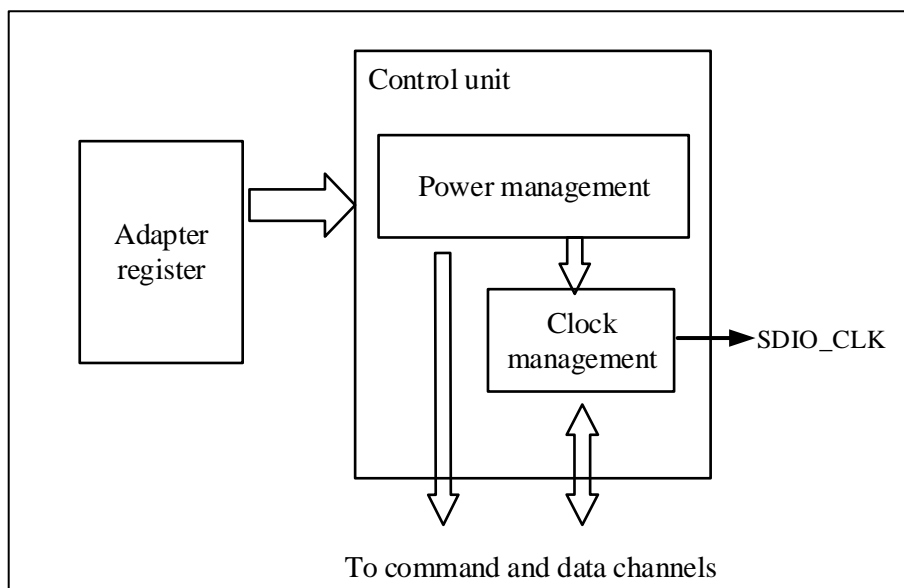

### 18.3.1.3 Command unit

The command unit and the card send and receive commands. The data transfer flow of the command channel is controlled by the command state machine (CPSM). The command transfer begins after setting SDIO\_CMDCTRL.CPSMEN bit to 1 and writing it once. First send a 48-bit command to the card through the SDIO\_CMD line, one bit of data per SDIO\_CLK. The 48-bit command contains 1 start bit, 1 transmit bit, 6-bit command index (defined SDIO\_CMDCTRL.CMDIDX bits), 32-bit parameters (defined by SDIO\_CMDARG), 7-bit CRC, and 1-bit stop bit. Then receive the response from the card when SDIO\_CMDCTRL.CMDIDX bits is not 0b00 or 0b10. The response is divided into a 48-bit short response and a 136-bit long response, and the responses are stored in the SDIO\_RESPONSE0~SDIO\_RESPONSE 3 registers. The command unit can also generate command status flags, which are defined in the SDIO\_STS register.

Figure 18-9 SDIO adapter command unit

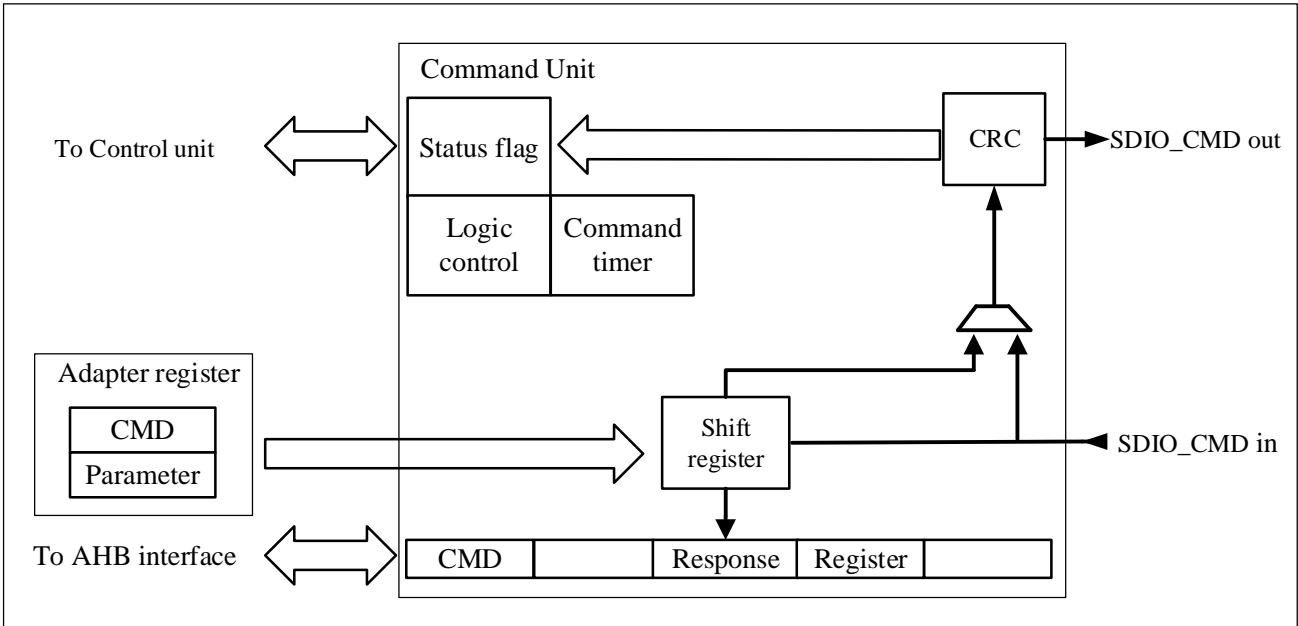

■ Command Path State Machine (CPSM)

Figure 18-10 Command Path State Machine (CPSM)

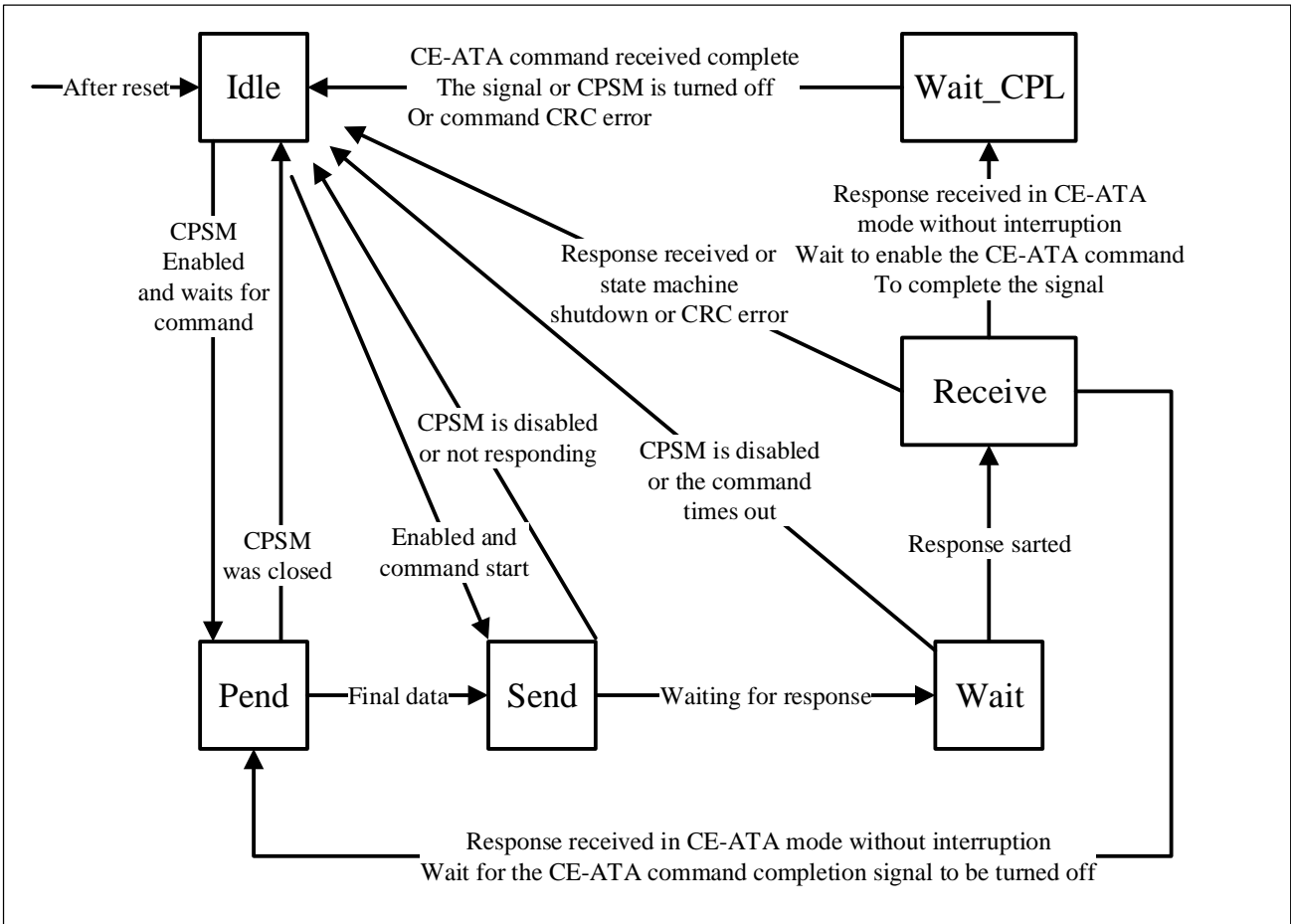

#### ◆ Idle

This state is an idle state. After the system is reset, the state is ready to send a command or the command state machine (CPSM) is turned off. All belong to the Idle state. When the command state machine (CPSM) is enabled, wait for the end of data transmission bit (SDIO\_CMDCTRL.WDATEND) Enable or disable can enter the Pend state.

*Note: The command state machine remains idle for at least 8 SDIO\_CLK cycles to meet NCC and NRC timing constraints. NCC is the minimum time interval between two host commands, and NRC is the minimum time interval between a host command and a card response.*

#### ◆ Pend

This state is a pending state, waiting for the end of data transfer. When the data transmission is completed, the command state machine enters the Send state from the Pend state; when the command state machine (CPSM) is turned off, the CPSM enters the Idle state.

#### ◆ Send

This state is the sending state, indicating that the command is being sent. If there is a response after the command is sent, the command state machine enters the Wait state, and if there is no response after the command is sent, the command state machine enters the Idle state.

#### ◆ Wait

This state is a wait state, waiting for the response start bit. When entering the wait (Wait) state, the command timer starts to run; if a response is received, that is, the start bit is detected, the command state machine (CPSM) enters the Receive state, and when the command state machine (CPSM) enters the receiving (Receive) state Before a timeout occurred, set the timeout flag and enter the Idle state.

*Note: The command timeout period is fixed at 64 SDIO\_CLK clock cycles.*

#### ◆ Receive

This state is the receiving state, the response is received and the CRC is checked.

Receive a response in CE-ATA mode, disable the CE-ATA interrupt and wait for the CE-ATA device command completion signal to be enabled and then enter the Wait\_CPL state.

Receive a response in CE-ATA mode, disable the CE-ATA interrupt and wait for the CE-ATA device command completion signal to be disable and then enter the Pend state.

The Idle state is entered when the CPSM is closed, a response is received, or the command CRC detection fails.

#### ◆ Wait\_CPL

In this state, wait for the CE-ATA device command completion signal, and enter the Idle state after receiving the CE-ATA command completion signal. It will also enter the Idle state when the CPSM is turned off or the command CRC check fails.

If the interrupt bit is set in the command register, the timer is turned off and the CPSM waits for an interrupt request from a certain card. If the pending bit is set in the command register, the CPSM enters the pending (Pend) state and waits for the CmdPend signal sent by the data channel subunit. When the CmdPend signal is detected, the CPSM enters the sending (Send) state, which will trigger the data counter to stop sending function of the command.

Figure 18-11 SDIO command transmission

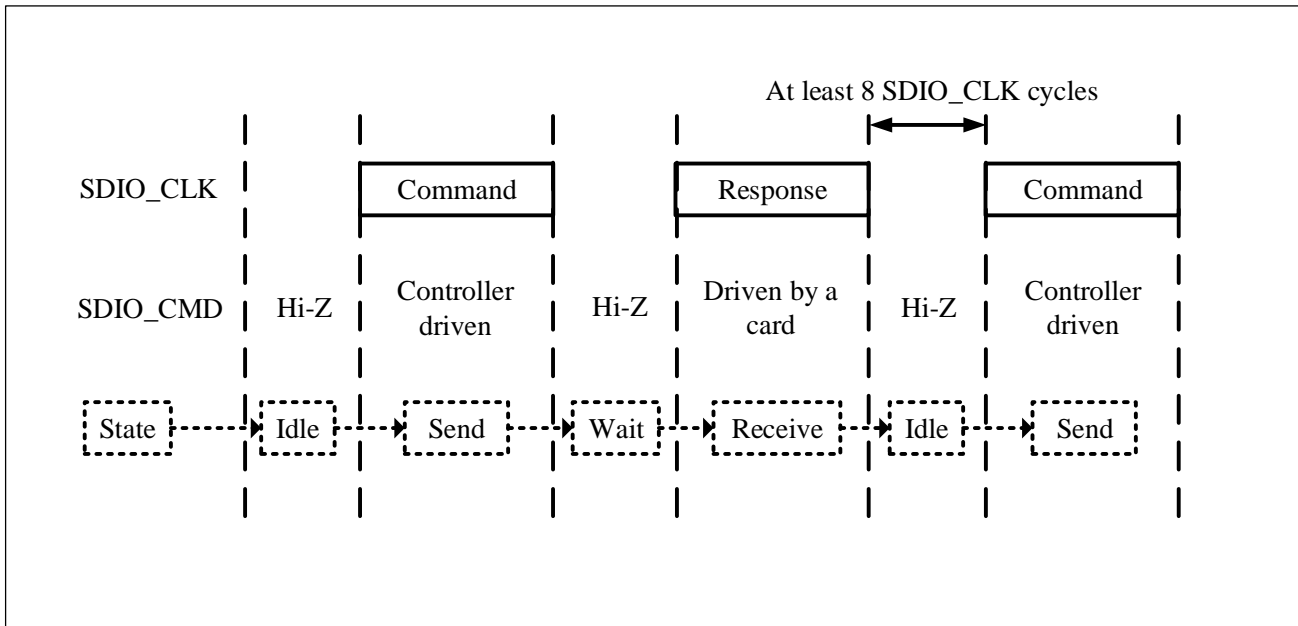

#### ■ Command register

The 6-bit command index and command type sent to the card are stored in the command register; the command type (see Section 18.7.4) determines whether and what type of response (48-bit or 136-bit).

Table 18-2 Command Channel Status Flags

| Flag                | Description  |
|---------------------|--|
| SDIO_STS.CMDRESPRCV | CRC correct response   |
| SDIO_STS.CCRCERR    | CRC error response   |
| SDIO_STS.CMDSEND    | Command (command that does not require a response) has been sent |
| SDIO_STS.CMDTIMEOUT | Response timeout   |
| SDIO_STS.CMDRUN     | Command transfer in progress                                     |

The CRC generator calculates the CRC checksum of all bits preceding the CRC code, including start bits, transmit bits, command index, and command parameters (or card status). For the long response format, the CRC checksum is calculated from the first 120 bits of the CID or CSD; note that the start bit, transmission bits and 6 reserved bits in the long response format do not participate in the CRC calculation.

The CRC checksum is a 7-bit value:

$$\text{CRC}[6:0] = \text{remainder} [(M(x) * x^7) / G(x)]$$

$$G(x) = x^7 + x^3 + 1$$

$$M(x) = (\text{start bit}) * x^{39} + \dots + (\text{last bit before CRC}) * x^0, \text{ or}$$

$$M(x) = (\text{start bit}) * x^{119} + \dots + (\text{last bit before CRC}) * x^0.$$

#### 18.3.1.4 Data channel

The data between the host and the card is transmitted through the data channel.

Figure 18-12 Data Channel

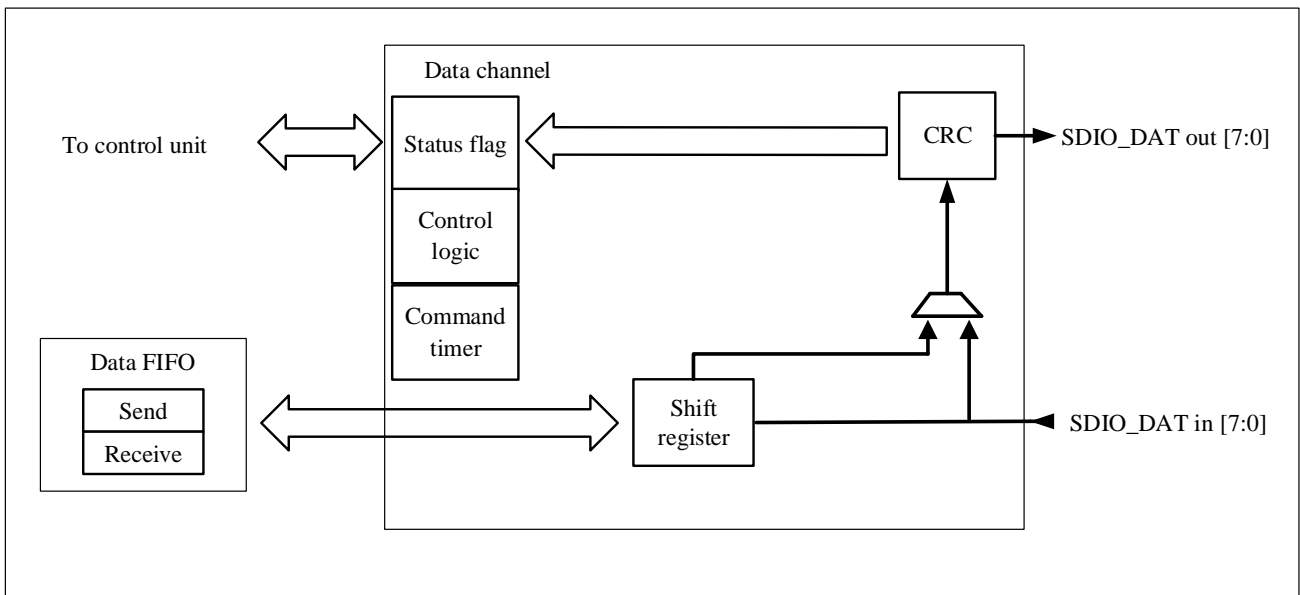

The data bus width of the card can be configured in the clock control register (SDIO\_CLKCTRL). When the data width is 4 bits (SDIO\_CLKCTRL.BUSMODE bit is 0b01), 4 bits of data will be transmitted on the four data signal lines SDIO\_DAT[3:0] in each clock cycle; when the data width is 8 bits (SDIO\_CLKCTRL.BUSMODE bit is 0b10), 8-bit data will be transmitted on the eight data signal lines SDIO\_DAT[7:0] per clock cycle; when the data width is 1 bit (SDIO\_CLKCTRL.BUSMODE bit is 0b00) or the bus mode is not selected, only 1 bit of data is transmitted on SDIO\_DAT0 per clock cycle.

The data transmission flow is controlled by the Data Channel State Machine (DPSM). Data transfer begins after a write to the SDIO\_DATCTRL register and setting the SDIO\_DATCTRL.DATEN bit to 1. When the SDIO\_DATCTRL.DATDIR bit is 0, the data is from the controller to the card, and the DPSM enters the Wait\_S state. If there is data in the transmit FIFO, the DPSM enters the transmit state, and the data channel subunit starts to send data to the card; when the DATDIR bit is When 1, the data is from the card to the controller, the DPSM enters the Wait\_R state, when the start bit is received, the DPSM enters the receiving state and waits for the start bit, and the data channel subunit starts to receive data from the card. Data units can also generate data status flags (defined in the SDIO\_STS register).

### 18.3.1.5 Data path state machine (DPSM)

The data channel state machine (DPSM) operates at the SDIO\_CLK frequency, and the card bus signal is synchronized with the rising edge of SDIO\_CLK. DPSM has 6 states, as shown in the following figure:

Figure 18-13 Data Path State Machine (DPSM)

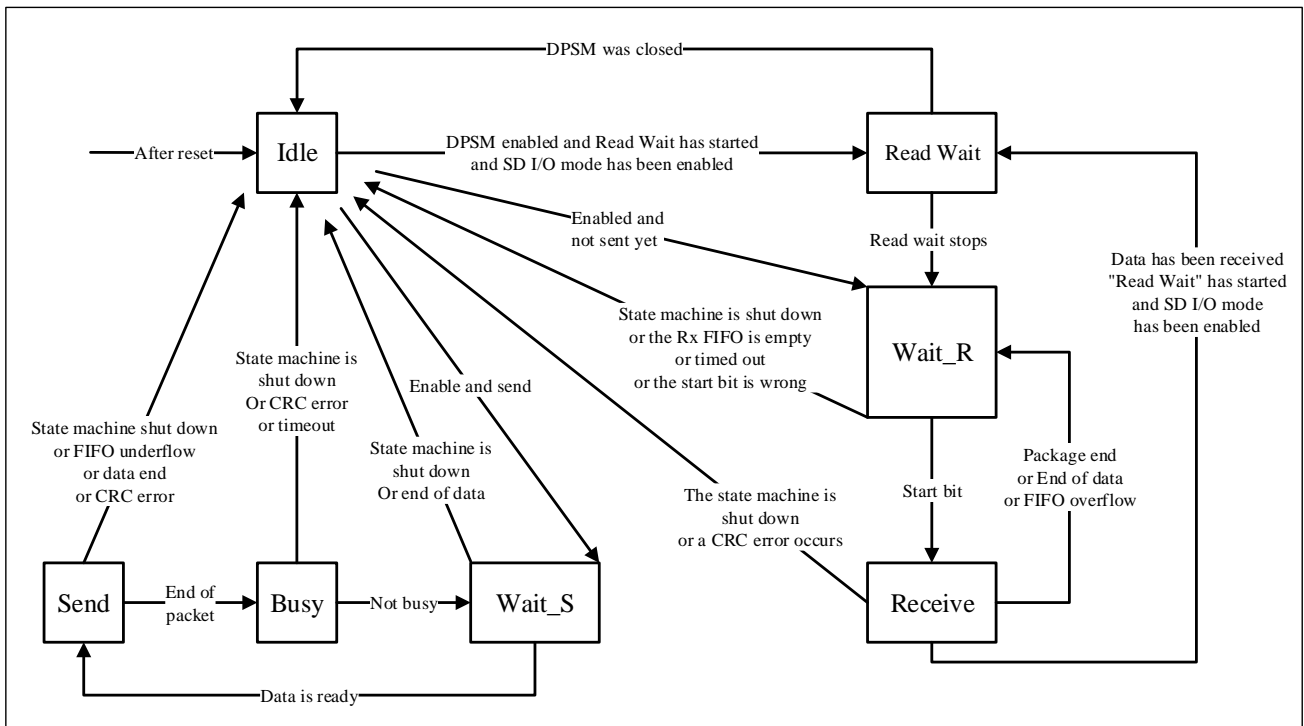

■ Idle:

In this state, the data channel does not work, waiting to transmit and receive data, and the SDIO\_DAT[7:0] output is in a high-impedance state. When the data control register is written and the enable bit is set, the DPSM loads a new value for the data counter, enters the Wait\_S state when the data transfer direction is from the host to the card, and enters the Wait\_R state when the data transfer direction is from the card to the host. The Read Wait state is entered when DPSM is enabled and a read wait has started and SD I/O mode is enabled.

■ Wait\_R:

In this state, the DPSM waits for the start bit of the received data. If the data times out (counter equals 0, when the receive FIFO is empty) the DPSM enters the Idle state. If the data counter is not equal to 0, the DPSM waits for a start bit on SDIO\_DAT; if the DPSM receives a start bit before the timeout, it enters the Receive state and loads the data block counter. If the DPSM times out before detecting a start bit, or if a start bit error occurs, the DPSM will go into the idle state and set the time-out status flag.

■ Receive:

In this state the DPSM receives the card's data and writes it to the data FIFO. Depending on the setting of the transfer mode bits in the data control register, the data transfer mode can be block transfer or stream transfer.

◆ In block mode, when the data block counter reaches 0, the DPSM waits to receive the CRC code, if the received code matches the internally generated CRC code, the DPSM enters the Wait\_R state, otherwise the CRC failure state flag is set and the DPSM enters the idle state state.

◆ In streaming mode, when the data counter is not 0, the DPSM receives data; when the counter is 0, the remaining data in the shift register is written into the data FIFO, and the DPSM enters the Wait\_R state. If a FIFO overflow error occurs, the DPSM sets the FIFO error flag and enters the idle state.

■ Wait\_S:

In this state, the DPSM waits for the data FIFO empty flag to be invalid or the end of the data transfer. If the data counter is 0, the DPSM enters the idle state; otherwise, the DPSM waits for the data FIFO empty flag to disappear before entering the sending state.

*Note: DPSM will remain in Wait\_S state for at least 2 clock cycles to meet the timing requirements of NWR. NWR is the interval from receiving the response from the card to when the host starts data transmission.*

■ **Send:**

In this state, the DPSM starts sending data to the card device. Depending on the setting of the transfer mode bits in the data control register, the data transfer mode can be block transfer or stream transfer:

- ◆ In block mode, when the data block counter reaches 0, the DPSM sends the internally generated CRC code, followed by the end bit, and enters the busy state.
- ◆ In streaming mode, when the enable bit is high and the data counter is not 0, the DPSM sends data to the card device, and then enters the idle state.
- ◆ If a FIFO underflow error occurs, the DPSM sets the FIFO error flag and enters the idle state.

■ **Busy:**

In this state, the DPSM waits for the CRC status flag:

- ◆ If the correct CRC status is not received, the DPSM enters the idle state and sets the CRC failure status flag.
- ◆ If the correct CRC status is received, and the card is not busy (SDIO\_DAT0 is not low), the DPSM enters the Wait\_S state.
- ◆ If the correct CRC status is not received, the DPSM enters the idle state and sets the CRC failure status flag.
- ◆ If the data timeout DPSM sets the data timeout flag and enters the idle state.
- ◆ When the DPSM is in Wait\_R or busy state, the data timer is enabled and can generate a data timeout error:
- ◆ When sending data, if the DPSM is in a busy state and exceeds the timeout interval set by the program, a timeout will occur.
- ◆ When receiving data, if all data is not received and DPSM is in Wait\_R state for more than the timeout interval set by the program, a timeout will occur

### 18.3.1.6 Data

Data can be transferred from the host to the card and vice versa.

Data is transmitted over the data line. Data is stored in a 32-word depth FIFO, each word is 32 bits wide.

Table 18-3 Data Token Format

| Description | Start bit | Data | CRC16 | End bit |
|-------------|-----------|------|-------|---------|
| Block Data  | 0         | -    | Yes   | 1       |
| Stream Data | 0         | -    | No    | 1       |

### 18.3.1.7 Data FIFO

The data FIFO unit has a data buffer for sending and receiving data buffers. The FIFO contains a data buffer and

transmit and receive circuits, where the buffer size is 32 bits wide per word, 32 words in total (32 words deep). The data FIFO operates in the AHB clock region (HCLK/2), and all signals connected to the SDIO clock region (SDIOCLK) are resynchronized.

Depending on the SDIO\_STS.TXRUN and SDIO\_STS.RXRUN flags, the FIFO can be turned off, transmit enabled, or receive enabled. SDIO\_STS.TXRUN and SDIO\_STS.RXRUN are set by the data channel subunit and are mutually exclusive:

- When SDIO\_STS.TXRUN is valid, the transmit FIFO represents the transmit circuit and data buffer
- When SDIO\_STS.RXRUN is valid, the receive FIFO represents the receive circuit and data buffer

**Transmit FIFO:** When the SDIO transmit function is enabled, data can be written to the transmit FIFO through the AHB interface. The transmit FIFO has 32 consecutive addresses. There is a data output register in the transmit FIFO that contains the data word pointed to by the read pointer. When the data channel subunit fills the shift register, it moves the read pointer to the next data and transfers the data out. If the transmit FIFO is not enabled, all status flags are inactive. When sending data, the data channel subunit sets SDIO\_STS.TXRUN to be valid.

Table 18-4 Transmit FIFO Status Flags

| Flag               | Description  |
|--------------------|--|
| SDIO_STS.TFIFO     | This flag is set high when all 32 transmit FIFO words have valid data.   |
| SDIO_STS.TFIFOE    | This flag is set high when all 32 transmit FIFO words have no valid data.  |
| SDIO_STS.TFIFOHE   | This flag is set high when 8 or more transmit FIFO words are empty. This flag can be used as a DMA request.                |
| SDIO_STS.TDATVALID | This flag is set high when the transmit FIFO contains valid data. The meaning of this flag is just the opposite of TFIFOE. |
| SDIO_STS.TXURERR   | This flag is set high when an underflow error occurs. This flag is cleared when writing to the SDIO clear register.        |

**Receive FIFO:** When the data channel subunit receives a data word, it will write the data into the FIFO. After the write operation is completed, the write pointer will automatically increase by one; at the other end, there is a read pointer that always points to the current data in the FIFO. If the receive FIFO is closed, all status flags are cleared and the read and write pointers are reset. The data channel subunit sets SDIO\_STS.RXRUN when data is received. The following table lists the status flags of the receive FIFO. The receive FIFO can be accessed through 32 consecutive addresses.

Table 18-5 Receive FIFO Status Flags

| Flag               | Description  |
|--------------------|--|
| SDIO_STS.RFIFO     | This flag is set high when all 32 transmit FIFO words have valid data.   |
| SDIO_STS.RFIFOE    | This flag is set high when all 32 transmit FIFO words have no valid data.  |
| SDIO_STS.RFIFOHF   | This flag is set high when 8 or more transmit FIFO words are empty. This flag can be used as a DMA request.                |
| SDIO_STS.RDATVALID | This flag is set high when the transmit FIFO contains valid data. The meaning of this flag is just the opposite of TFIFOE. |
| SDIO_STS.RXORERR   | This flag is set high when an underflow error occurs. This flag is cleared when writing to the SDIO clear register.        |

## 18.3.2 SDIO AHB Interface

The AHB interface implements access to SDIO registers, data FIFOs, and generation of interrupts and DMA requests. Includes data channel, register decoder, and interrupt/DMA control logic.

### 18.3.2.1 SDIO interrupt

When at least one of the selected status flags is high, the interrupt control logic generates an interrupt request. The interrupt enable register allows the interrupt logic to generate the corresponding interrupt.

### 18.3.2.2 SDIO/DMA Interface

The DMA interface provides a way to quickly transfer data directly between the SDIO data FIFO and memory.

The following example details how to implement this method. The host controller uses CMD24 (WRITE\_BLOCK) to transfer 512 bytes from the host to the MMC card, and the DMA controller is used to fill the SDIO FIFO with data from the memory.

1. Complete the card identification process
2. Increase SDIO\_CLK clock frequency
3. Send CMD7 command to select card and configure bus width
4. The configuration process of DMA2 is as follows:
  - a) Enable DMA2 controller and clear all interrupt flags
  - b) Use the base address of the memory buffer to set the source address register of DMA2 channel 4, and use the address of the SDIO\_FIFO register to configure the destination address register of DMA2 channel4.
  - c) Set the control register of DMA2 channel 4(the memory address pointer is incremented, the peripheral address pointer is fixed, and the data width of memory and peripherals is word width)
  - d) Enable DMA2 channel 4
5. The process of writing a data block (CMD24) is as follows:
  - a) Set the SDIO data length register, write the data size in bytes into the SDIO\_DATLEN register, write the block size in bytes into the SDIO\_DATCTRL register, and then the host sends data in each block size (BLKSIZE).
  - b) Write the address of the data to the SDIO parameter register SDIO\_CMDARG, which is the address of the card that needs to transmit data
  - c) Set the SDIO command control register (SDIO\_CMDCTRL): SDIO\_CMDCTRL.CMDIDX is set to 24 (WRITE\_BLOCK); SDIO\_CMDCTRL.CMDRESP[1:0] is set to 1 (SDIO card host waits for a response); SDIO\_CMDCTRL.CMDRESP is set to 1 (SDIO card host waits for a short response); SDIO\_CMDCTRL.CPSMEN is set to 1 (enable SDIO card host sends commands), other fields are their reset values.
  - d) Wait for SDIO\_STS.CMDRESPRECV bit is set, and then configure the SDIO data control register: SDIO\_DATCTRL.DATEN is set to 1 (the SDIO card host is enabled to send data); SDIO\_DATCTRL.DATDIR is set to 0 (the transmission direction is from the controller to the card); SDIO\_DATCTRL.TRANSMOD is set to 0 (block data transfer); SDIO\_DATCTRL.DMAEN is set to 1

(DMA enabled); SDIO\_DATCTRL.BLKSIZE is set to 9 (512 bytes); other fields do not need to be set.

e) Bit10 DATBLKEND flag bit of wait status register SDIO\_STS is set.

6. Query the enable status register of the DMA channel to confirm that no channel is still enabled.

## 18.4 Card function description

### 18.4.1 Confirmation of working voltage range

All cards can use any voltage within the specified range to communicate with the SDIO card host, the minimum and maximum voltage VDD values that can be supported are defined by the operating condition register (OCR) on the card. When communication between the host and the card is initiated, the host may not know the voltages supported by the card, and the card may not know whether the host can provide the voltages it supports. In order to verify the voltage, a series of special commands are required, which are defined in the relevant specifications.

The commands defined in the protocol specification include: CMD1 (SEND\_OP\_COND, for MMC), ACMD41 (SD\_APP\_OP\_COND, for SD memory cards) and CMD5 (IO\_SEND\_OP\_COND, for SD I/O cards). These commands provide a mechanism for the host to identify and reject cards that do not match the VDD range required by the host. This is because a card whose internal memory stores the Card Identification Number (CID) and Card Specific Data (CSD) can only transmit these information under the condition of data transfer VDD. When the SDIO card host module is inconsistent with the VDD range of the card, the card will not be able to complete the identification cycle and cannot send CSD data; therefore, when the VDD range does not match, the SDIO card host can use these special commands to identify and reject the card. The SDIO card host will generate the required VDD voltage when executing these commands. Cards that cannot transmit data within the specified voltage range are disconnected from the bus and become inactive.

If the card cannot operate at the supplied voltage, it does not return a response and remains in an idle state. It is mandatory to send CMD8 before ACMD41 command when initializing SD card. Receiving CMD8 is to let the card know that the host supports the physical layer 2.00 protocol and the card supports higher version functions. If the card can operate at the supplied voltage, the response will return the supply voltage and the check mode set in the command parameter.

### 18.4.2 Card reset

The CMD0 command (GO\_IDLE\_STATE) is a software reset command, which sets the multimedia card (MMC) and SD memory card into the idle state (Idle State). Regardless of the current card state. The reset command (CMD0) is only used for the memory part of the memory or combination card. The CMD52 command (IO\_RW\_DIRECT) resets the SD I/O card. Cards in the Inactive State are not affected by this command.

After the host is powered on, all cards are in the idle state (Idle State), including the cards that were previously in the inactive state (Inactive State). After power-on or after executing CMD0, the outputs of all cards are in a high-impedance state. The CMD lines of all cards are in input mode, waiting for the start bit of the next command, while all cards are initialized to a default relative card address (RCA=0x0001) and driven with a default clock frequency of 400kHz (lowest speed, maximum current drive capability).

### 18.4.3 Card identification mode

After the host resets, it enters the card identification mode to search for a new card on the bus. In card identification mode, the host resets all cards, verifies the operating voltage range, identifies the cards and asks each card for the relative card address (RCA). This operation is done separately on each card's own command signal line CMD. All data communication in card identification mode uses only the command line (CMD). During card identification, the card should operate at clock rate  $F_{OD}$  (400 kHz).

### 18.4.4 Card identification process

The identification process of different cards is different; for multimedia cards, the card identification process starts with the clock frequency  $F_{od}$ , and all SDIO\_CMD outputs are driven open, allowing parallel connection of cards during this process.

The identification process of the multimedia card is as follows:

1. The bus is enabled
2. The SDIO card host broadcasts the CMD1 (SEND\_OP\_COND) command, receives the operating conditions, and obtains the "wire AND" of the contents of the operating condition registers of all cards
3. If the card is not compatible, it will be placed in an inactive state
4. The SDIO card host broadcasts a CMD2 command (ALL\_SEND\_CID) to all active cards. All active cards simultaneously send their CID numbers serially. Those cards that detect that the output CID bits do not match the data on the command line must Stop sending and wait for the next recognition cycle. In the end, only one card can successfully transmit the complete CID to the SDIO card host and enter the identification state.
5. The SDIO card host sends a CMD3 command (SET\_RELATIVE\_ADDR) to the card. This new address is called the relative card address (RCA), which is shorter than the CID and is used to address the card. At this point, the card goes into a standby state and no longer responds to the new identification process, and at the same time its output drive changes from open circuit to push-pull mode.
6. The SDIO card host repeats steps 4 and 5 above until a timeout condition is received.

The SD card identification process starts with the clock frequency  $F_{od}$ , and all SDIO\_CMD outputs are push-pull drivers instead of open-circuit drivers. The identification process is as follows:

1. The bus is enabled
2. The SDIO card host broadcasts the ACMD41 (SEND\_APP\_OP\_COND) command to get the contents of the operating condition registers of all cards
3. If the card is not compatible, it will be placed in an inactive state
4. The SDIO card host broadcasts CMD2 (ALL\_SEND\_CID) to all activated cards, and all activated cards return their unique card identification number (CID) and enter the identification state.
5. The SDIO card host sends a CMD3 (SET\_RELATIVE\_ADDR) command and an address to an activated card, this new address is called relative card address (RCA), which is shorter than CID and is used to address the card. At this point, the card goes into the standby state. The host of the SDIO card can send this command again to change the RCA, and the RCA of the card will be the last assignment.

6. The SDIO card host repeats steps 4 and 5 above for all activated cards until a timeout condition is received.

The SD I/O card identification process is as follows:

1. The bus is enabled
2. The SDIO card host sends the CMD5 (IO\_SEND\_OP\_COND) command to get the contents of the card's operating condition register
3. If the card is not compatible, it will be placed in an inactive state
4. The SDIO card host sends a CMD3 (SET\_RELATIVE\_ADDR) command and an address to an activated card, this new address is called relative card address (RCA), which is shorter than CID and is used to address the card. At this point, the card goes into the standby state. The host of the SDIO card can send this command again to change the RCA, and the RCA of the card will be the last assignment.

### 18.4.5 Write data block

When the write data block command (CMD24-27) is executed, one or more data blocks are transferred from the host to the card (1-bit or 4-bit high level). If the CRC check is wrong, the card indicates a transfer failure via the SDIO\_DAT signal line, the transferred data is discarded without being written, and all subsequent (in multi-block write mode) transferred data blocks will be ignored.

If the host transmits partial data and the accumulated data length is not aligned with the data block, and block misalignment is not allowed (parameter WRITE\_BLK\_MISALIGN for CSD is not set), the card will detect block misalignment errors before the start of the first unaligned block (set the ADDRESS\_ERROR error bit in the status register) and ignore subsequent data transfers at the same time. The write operation is also aborted when the host attempts to write to a write-protected area, in which case the card will set the WP\_VIOLATION bit in the status register.

Setting the CID and CSD registers does not require setting the block length in advance, and the transmitted data is also protected by CRC. If part of the CSD or CID register is stored in ROM, then this unchangeable part must match the corresponding part of the receive buffer. If there is an inconsistency, the card will report an error without modifying the contents of any register.

Some cards may take a long or unpredictable time to complete the writing of a data block. After receiving a data block and completing the CRC check, the card will start the write operation. If the write buffer is full and cannot be re-issued with a new WRITE\_BLOCK command. When receiving new data, it will pull the SDIO\_DAT signal line low. The host can use SEND\_STATUS (CMD13) to query the status of the card at any time, and the card will return the current status. The status bit READY\_FOR\_DATA indicates whether the card can accept new data or whether a write operation is still in progress. The host can unselect the card (select another card) by sending the CMD7 command, and put the card in the disconnected state, which can release the SDIO\_DAT signal line without interrupting the outstanding write operation; when a card is reselected, if the write operation is still in progress and the write buffer is still unavailable, it will again indicate the busy state by pulling the SDIO\_DAT signal line low.

### 18.4.6 Read data block

The read data block is a block-based data transfer. The basic unit of data transfer is a data block. The size of the block is defined in CSD (READ\_BL\_LEN). If READ\_BL\_PARTIAL is set, smaller blocks of data can also be transferred, whose start and end addresses are fully contained within the 512-byte boundary, and READ\_BL\_LEN defines the

size of the physical block.

CMD17 (READ\_SINGLE\_BLOCK) means to start reading a data block, and the card returns to the sending state after the transmission is over. CMD18 (READ\_MULTIPLE\_BLOCK) starts to read multiple consecutive data blocks. In order to ensure the integrity of data transmission, there is a CRC check code after each data block.

The block length is set by CMD16 and can be set to 512 bytes regardless of the setting of READ\_BL\_LEN.

The host can abort a multi-block read operation at any time, regardless of the type of operation. Send a stop transfer command (CMD12) to abort the operation. The stop command has a delay in execution due to serial command transmission. Data transfer is stopped after the end bit of the stop command.

When using CMD18 to read the last block of userland, the host should ignore possible OUT\_OF\_RANGE errors, even if the sequence is correct.

If the card detects an error (for example: out-of-bounds, address misplacement, or internal error) during a multi-block read operation (of either type), it stops the data transfer and remains in the data state; at this point the host must send a stop transfer command to abort operate. Read errors are reported in response to the stop transfer command. If the host sends the stop transmission command, the card has already transmitted the last data block in a certain number of multiple data block operations, because the card is no longer in the data state at this time, the host will get an illegal command response. If the cumulative length of the partial blocks transferred by the host is not block aligned and block misalignment is not allowed, the card will detect block misalignment at the beginning of the first unaligned block, set the ADDRESS\_ERROR error flag in the status register, interrupt the transfer and wait for the data Status of the stop command.

## 18.4.7 Data Streaming Operation (Only for Multimedia Card)

Data stream operations include data stream write and data stream read. In streaming mode, data is transferred in bytes without CRC after each data block.

### 18.4.7.1 Data stream write

Data stream writing to CMD20 (WRITE\_DAT\_UNTIL\_STOP) starts to transmit data from the host to the card, starting from the starting address and continuing to transmit until the host issues a stop command. If partial data block transfers are allowed (CSD parameter WRITE\_BL\_PARTIAL is set), data flow can be started and stopped at any address in the card's address space, otherwise data flow should only be started and stopped at data block boundaries. Since the amount of data to be transmitted is not predetermined, the CRC check cannot be used. If the maximum memory address is reached when sending data, subsequent data transfers will be discarded even if the SDIO card host does not send a stop command.

If the host provides an out-of-range address as a parameter to CMD20, the card will reject the command, stay in the transmit state, and set ADDRESS\_OUT\_OF\_RANGE; it should be noted that the data stream write command is only applicable to 1-bit bus configuration (SDIO\_DAT0 signal on-line). It is considered an illegal command if CMD20 is issued in other bus configuration.

The maximum clock frequency for streaming write operations is calculated by the formula given below:

$$Max\_Write\_Frequency = Min(TRAN\_SPEED, \frac{8 \times 2^{WRITE\_BL\_LEN} - 100 \times NSAC}{TAAC \times R2W\_FACTOR})$$

- Max\_Write\_Frequency: maximum write frequency

- TRAN\_SPEED: Maximum bus clock frequency
- WRITE\_BL\_LEN: maximum write block length
- NSAC: Data read operation time in CLK cycles 2
- TAAC: Data read operation time 1
- R2W\_FACTOR: Write speed factor

All parameters are defined in CSD registers. If the host attempts to use a higher frequency, the card may not be able to process the data and stop programming while setting the error bit SDIO\_STS.RXORERR in the status register and ignoring all subsequent data transfers, waiting (in the receive data state) for a stop command . If the host attempts to write a value in the write-protected area, the write operation will be aborted and the card will set the WP\_VIOLATION bit.

### 18.4.7.2 Data stream read

Data Streaming Data transfer is controlled by the READ\_DAT\_UNTIL\_STOP (CMD11) command.

This command requires the card to read data from the specified address until the SDIO card host sends a STOP\_TRANSMISSION (CMD12) command. Due to the delay of serial command transmission, the execution of the stop command will have a certain delay, so the data transfer will not stop until the end bit of the stop command. If the host provides an out-of-range address as a parameter to pass to CMD11, the card will reject the command and stay in the transfer state, the SDIO card host does not send a stop command, and the subsequently transferred data is also considered invalid data.

Another point to note is that the data stream read command only works in 1-bit bus mode (SDIO\_DAT0 signal line). If CMD11 is issued in other bus configurations, the command is considered illegal.

The maximum clock frequency for stream read operations can be calculated as:

$$Max\_Read\_Frequency = Min(TRAN\_SPEED, \frac{8 \times 2^{READ\_BL\_LEN} - 100 \times NSAC}{TAAC \times R2W\_FACTOR})$$

- Max\_Read\_Frequency: maximum read frequency
- TRAN\_SPEED: maximum data transfer rate
- READ\_BL\_LEN: maximum read data block length
- NSAC: Data read operation time in CLK cycles2
- TAAC: Data read operation time 1
- R2W\_FACTOR: Write speed factor

If the host tries to use a higher frequency, the card will not be able to process the data transfer, at this time the card sets the SDIO\_STS.TXURERR error bit in the status register, aborts the data transfer and waits for a stop command in the data state.

### 18.4.8 Erase

Erase includes block erase and sector erase. The erasing unit of the multimedia card is the erasing group, the basic writing unit of the card is the writing data block, and the erasing group is calculated by the writing data block. The size of the erase group is a card specific parameter and is defined in the CSD.

The host can erase a contiguous range of erase groups. There are three steps involved in starting the erase operation. First, the host uses the ERASE\_GROUP\_START (CMD35) command to define the start address in the contiguous range, then uses the ERASE\_GROUP\_END (CMD36) command to define the end address of the contiguous range, and finally sends the erase command ERASE (CMD38) to start the erase operation. In the erase command, the address field is the erase group address in bytes. The card discards the portion that is not aligned with the size of the erase group and aligns the address boundary to the boundary of the erase group.

If an erase command (CMD35, CMD36, CMD38) is not received as described above, the card should set the ERASE\_SEQ\_ERROR bit in the card status register and restart the erase operation (waiting for the first step).

If a command other than SEND\_STATUS and erase command is received, the card should set ERASE\_RESET in the status register, reset the erase sequence and execute the new command.

If the erase range includes write-protected data blocks, the write-protected area will not be erased, only non-protected blocks can be erased, and the card should set the WP\_ERASE\_SKIP status bit in the status register.

If the host supplies an out-of-range address as an argument to CMD35 or CMD36, the card will reject the command, set the ADDRESS\_OUT\_OF\_RANGE bit in the status register, and reset the entire erase sequence.

During the entire erasing process, Kara low SDIO\_DAT signal. The actual erase time may be long, and the host can send a CMD7 command to deselect the card.

## 18.4.9 Wide bus selection and de-selection

The default bus width is 1 bit after the card is powered on or after the GO\_IDLE\_STATE (CMD0) command. The bus width can be changed after the host has verified the functional pins on the bus and the card is initialized.

The wide bus (4-bit bus width) operation mode can be selected by the SET\_BUS\_WIDTH (ACMD6) command, it should be noted that the SET\_BUS\_WIDTH (ACMD6) command is only valid in the transfer state, which means that only after the card is selected using the SELECT/DESELECT\_CARD (CMD7) command to change the bus width.

## 18.4.10 Protection management

The host supports three card protection methods to protect data from being erased or rewritten:

1. Internal write protection of the card
2. Physical write protection switch
3. Card lock operation for password management

### 18.4.10.1 Write protection of internal cards

By permanently or temporarily setting the write-protect bit in the CSD, the user can permanently write-protect the entire card to prevent the card's data from being overwritten or erased. Some cards set the write protection of a group of sectors by setting the WP\_GRP\_ENABLE bit of the CSD, so that only part of the data can be selected to be protected. Write protection can be changed by program. The basic unit of write protection is the CSD parameter WP\_GRP\_SIZE sectors. Users can customize the size of the write protection area by configuring the value of WP\_GRP\_SIZE. The SET\_WRITE\_PROT command sets the write protection of the specified write protection group, and the CLR\_WRITE\_PROT command clears the write protection of the specified write protection group. The SEND\_WRITE\_PROT command requests the device to send the status of the write protection bit. This command is

similar to the single data block read command. A data block of write protection bits, which represents 32 write protection groups starting from the specified address, followed by a 16-bit CRC code at the end. The address field of the write protect command is a group address in bytes, the card will truncate all addresses outside the group size.

### 18.4.10.2 Physical write protection switch

There is a mechanical slide switch on the side of the card, which provides the user with setting whether to write-protect the card. When the sliding switch is placed in the open position of the small window, the card is in write-protected state, and when the sliding switch is placed in the closed position of the small window, the card is not write-protected, and the user can modify the content in the card. There is also a switch on the corresponding part of the slot of the card to indicate whether the card is in the write-protected state. It should be noted that this instruction is for the SDIO card host module, and the internal circuit of the card does not know the position of the write-protect switch.

### 18.4.10.3 Password protection

Password protection means that the host module can lock or unlock the card with a password. The password is stored in the 128-bit PWD register, and the length of the password is stored in the 8-bit register of PWDS\_LEN. These registers are non-volatile, so their contents are not lost after a power loss. The locked card supports all basic commands, such as reset, initialization, and status query commands sent by the SDIO card host module. If the card has previously set a password (that is, the value of PWDS\_LEN is not 0), the card will be automatically locked after each power-on.

The same as the CSD and CID register write commands, the lock/unlock command is only valid in the transmission state, which also means that the card must be selected before using the lock/unlock command, and there is no address parameter in this command. of.

The structure and bus operation type of the lock/unlock command of the card are the same as the single data block write command of the card. The data block transmitted by the command contains the information required by the command, such as password setting mode, PWD content and lock/unlock instructions. Before sending the lock/unlock command of the card, the SDIO card host module has defined the length of the command data block. The structure of the command is shown in Table 18-6.

Table 18-6 Lock/Unlock Data Structure

| Byte       | Bit7                    | Bit6 | Bit5 | Bit4 | Bit3  | Bit2        | Bit1    | Bit0    |
|------------|-------------------------|------|------|------|-------|-------------|---------|---------|
| 0          | Reserved (Remains at 0) |      |      |      | ERASE | LOCK_UNLOCK | CLR_PWD | SET_PWD |
| 1          | PWDS_LEN                |      |      |      |       |             |         |         |
| 2          | Password Data (PWD)     |      |      |      |       |             |         |         |
| .....      |                         |      |      |      |       |             |         |         |
| PWDS_LEN-1 |                         |      |      |      |       |             |         |         |

- ERASE: Setting this bit to 1 will perform a forced erase, all other bits must be 0. In this case only the command byte is sent, all other bytes of the command will be ignored by the card.
- LOCK\_UNLOCK: When this bit is 1, it means the card is locked, and when it is 0, it means it is unlocked. This bit can be set at the same time as SET\_PWD, but not at the same time as CLR\_PWD.
- CLR\_PWD: Set this bit to 1 clear password data.
- SET\_PWD: This bit is 1 to save the password data to the memory.
- PWDS\_LEN: This parameter defines the length of the password, in bytes.

- PWD: password data, according to different commands, the password data is different. For example, in the case of setting a new password, it contains the new password, and when changing the password, it contains the old password and the new password set.

The following sections list the command sequences to set/clear password, lock/unlock, and force wipe.

#### **18.4.10.4 Set password**

1. If the card has not been selected before, use the CMD7 (SELECT/DESELECT\_CARD) command to select a card.
2. Use CMD16 (SET\_BLOCKLEN) to define the length of the data block, the 8-bit card lock/unlock mode, the 8-bit PWDS\_LEN (in bytes), and the number of bytes of the new password. When the password replacement is completed, the size of the data block in which the command is sent must take into account the lengths of both the old and new passwords.
3. On the data line, send the CMD42 (LOCK/UNLOCK) command with a suitable data block length and include a 16-bit CRC code. The data block contains the operation mode (SET\_PWD=1), the password length (PWDS\_LEN) and the password data itself (PWD). When the password replacement is completed, the password length value (PWDS\_LEN) should be the sum of the lengths of the old and new passwords. The password data field (PWD) is preceded by the old password (in use) and followed by the new password.
4. When the old password sent is incorrect (size or content does not match the expected value), LOCK\_UNLOCK\_FAILED in the status register will be set and the old password will not be changed. If the old password matches, the new password data and length are stored in PWD and PWDS\_LEN respectively.

The password length field (PWDS\_LEN) can indicate whether a password is currently set. If the field is zero, it means that the password is not used. Only when the field is not zero, the card will be automatically locked when powered on. If a password is set, and you want to lock the card immediately without power failure, you can set the LOCK\_UNLOCK bit or send an additional lock command.

#### **18.4.10.5 Clear password**

1. If the card has not been selected before, use the CMD7 (SELECT/DESELECT\_CARD) command to select a card.
2. Use CMD16 (SET\_BLOCKLEN) to define the data block length, 8-bit card lock/unlock mode, 8-bit PWDS\_LEN (in bytes), and the number of bytes of the currently used password.
3. On the data line, send the CMD42 (LOCK/UNLOCK) command with a suitable data block length and include a 16-bit CRC code. The data block contains the operating mode (CLR\_PWD), the password length (PWDS\_LEN) and the password data itself (PWD). If the passwords match, the contents of PWD will be cleared and PWDS\_LEN will be set to 0. If the contents of PWD and PWDS\_LEN do not match the transmitted password and its size, the LOCK\_UNLOCK\_FAILED error bit in the status register is set and the password is unchanged.

#### **18.4.10.6 Card lock**

1. If the card has not been selected before, use the CMD7 (SELECT/DESELECT\_CARD) command to select a card.
2. Use CMD16 (SET\_BLOCKLEN) to define the data block length, 8-bit card lock/unlock mode, 8-bit PWDS\_LEN indicates the number of bytes of the currently used password.
3. On the data line, send the CMD42 (LOCK/UNLOCK) command with a suitable data block length and include

a 16-bit CRC code. The data block contains the operation mode (LOCK\_UNLOCK=1), the password length (PWDS\_LEN) and the password data itself (PWD).

4. If the PWD content is equal to the sent password, the card will be locked and the CARD\_IS\_LOCKED status bit in the status register will be set. If the sent password does not match the expected password (length or content), the LOCK\_UNLOCK\_FAILED error bit in the status register is set and the lock operation fails.

Setting the password and locking the card can be performed simultaneously in the same sequence of operations. In this case, the card host module first sets the password according to the above steps. It should be noted that the LOCK\_UNLOCK bit should be set in the third step of sending the new password command.

Only the card that has previously set a password (PWDS\_LEN is not 0) will be automatically locked when it is powered on and reset. Locking a card that is already locked or a card without a password will fail and set the LOCK\_UNLOCK\_FAILED error bit in the status register.

#### 18.4.10.7 Card unlock

1. If the card has not been selected before, use the CMD7 (SELECT/DESELECT\_CARD) command to select a card.
2. Use CMD16 (SET\_BLOCKLEN) to define the data block length, 8-bit card lock/unlock mode, 8-bit PWDS\_LEN (in bytes), and the number of bytes of the currently used password.
3. On the data line, send the CMD42 (LOCK/UNLOCK) command with a suitable data block length and include a 16-bit CRC code. The data block contains the operation mode (LOCK\_UNLOCK=0), the password length (PWDS\_LEN) and the password data itself (PWD).
4. If the sent password does not match the expected password (length or content), set the LOCK\_UNLOCK\_FAILED error bit in the status register to 1, while the card remains locked. When the password is matched, the card lock is released, and the CARD\_IS\_LOCKED bit in the status register is cleared at the same time.

If the unlocked state is only valid during the current power supply process, as long as the PWD is not cleared, the card will still be automatically locked after the next power-on.

Attempting to unlock an already unlocked card will cause the operation to fail and set the LOCK\_UNLOCK\_FAILED error bit in the status register.

#### 18.4.10.8 Force erase

A forced erase operation can erase all data and passwords in the card. If the user forgets the password, the card can be made available again through a forced wipe operation.

1. If the card has not been selected before, use the CMD7 (SELECT/DESELECT\_CARD) command to select a card.
2. Use CMD16 (SET\_BLOCKLEN) to define the data block length, 8-bit card lock/unlock mode, 8-bit PWDS\_LEN indicates the number of bytes of the currently used password.
3. Send a CMD42 (LOCK/UNLOCK) command with a suitable data block length on the data line and include a 16-bit CRC code. The data block contains the operating mode (ERASE=1) all other bits are 0.
4. If and only if the ERASE bit in the data field is 1, all contents of the card will be erased, including the PWD and PWDS\_LEN fields. The card is no longer locked after erasing. If any other bit is not 0, set the

LOCK\_UNLOCK\_FAILED error bit in the status register, the data in the card remains unchanged, and the card remains locked.

*NOTE: Attempting to perform an erase operation on an already unlocked card will cause the operation to fail and set the LOCK\_UNLOCK\_FAILED error bit in the status register.*

## 18.4.11 Card status register

### 18.4.11.1 Card status register

Card status refers to the error and status information of the executed command, indicated in the response.

Generally, after receiving a command, the card will return the status information related to the command to the card host. These status information may be stored in the local status register. This status information is called the card's status field, and the response format R1 contains a 32-bit field called the card status.

Table 18-7 defines the different status messages.

Table 18-7 Card Status

| Bits | Identifier           | Type | Value                     | Description   | Clear condition |
|------|----------------------|------|---------------------------|---|-----------------|
| 31   | ADDRESS_OUT_OF_RANGE | EXR  | '0'=no error<br>'1'=error | The address parameter in the command is out of the allowed range for the card.<br>A multi-block or stream read/write operation (even from a valid address) attempts to read or write beyond the capacity of the card.   | C               |
| 30   | ADDRESS_MISALIGN     |      | '0'=no error<br>'1'=error | The first data block defined by the address parameter in the command (contrasted with the current data block length) is not aligned with the card's physical block.<br>A multi-block or stream read/write operation (even if starting at a legal address) attempts to read or write a block of data that is not aligned with the physical block.                        | C               |
| 29   | BLOCK_LEN_ERROR      |      | '0'=no error<br>'1'=error | The parameter of the SET_BLOCKLEN command exceeds the maximum allowable range of the card, or the previously defined data block length is illegal for the current command (for example: the host issues a write command, the current block length is less than the minimum length allowed by the card, and at the same time Partial data block writing is not allowed). | C               |
| 28   | ERASE_SEQ_ERROR      |      | '0'=no error<br>'1'=error | Erase commands were sent in the wrong order.  | C               |
| 27   | ERASE_PARAM          | EX   | '0'=no error<br>'1'=error | An illegal erase group was selected while erasing.  | C               |
| 26   | WP_VIOLATION         | EX   | '0'=no error              | An attempt was made to program a write-protected  | C               |

| Bits | Identifier         | Type | Value   | Description  | Clear condition |
|------|--------------------|------|---|--|-----------------|
|      |                    |      | '1'=error   | block of data.   |                 |
| 25   | CARD_IS_LOCKED     | SR   | '0'=card unlocked<br>'1'=card locked  | When this bit is set, it means the card has been locked.   | A               |
| 24   | LOCK_UNLOCK_FAILED | EX   | '0'=no error<br>'1'=error   | Wrong sequence of commands in lock/unlock or wrong password detected.  | C               |
| 23   | COM_CRC_ERROR      | ER   | '0'=no error<br>'1'=error   | CRC check error in previous command.   | B               |
| 22   | ILLEGAL_COMMAND    | ER   | '0'=no error<br>'1'=error   | The command is illegal for the current card state.   | B               |
| 21   | CARD_ECC_FAILED    | EX   | '0'=success<br>'1'=failure  | The ECC check is implemented inside the card, but it fails to correct the data.  | C               |
| 20   | CC_ERROR           | ER   | '0'=no error<br>'1'=error   | (Not defined in the standard) An error occurred inside the card, independent of a command from the host.   | C               |
| 19   | ERROR              | EX   | '0'=no error<br>'1'=error   | An internal card error (eg: read or write error) related to the execution of the last host command (not defined in the standard) has occurred.   | C               |
| 18   | Reserved           |      |   |  |                 |
| 17   | Reserved           |      |   |  |                 |
| 16   | CID/CSD_OVERWRITE  | EX   | '0'=no error<br>'1'=error   | Can be any of the following errors:<br>The CID register has been written and cannot be overwritten;<br>The read-only portion of the CSD does not match the contents of the card;<br>An attempt was made to reverse the copy or permanent write protection, i.e. restore or release write protection. | C               |
| 15   | WP_ERASE_SKIP      | EX   | '0'= not protected<br>'1'= protected  | Encountering an existing write-protected data block, only part of the address space is erased.   | C               |
| 14   | CARD_ECC_DISABLED  | SX   | '0'=enabled<br>'1'=disabled   | No internal ECC is used when executing the command.  | A               |
| 13   | ERASE_RESET        |      | '0'=clear<br>'1'=set  | The sequence into the erase process was aborted because a command outside the erase sequence was received (not a CMD35, CMD36, CMD38, or CMD13 command).   | C               |
| 12:9 | CURRENT_STATE      | SR   | '0'= Idle<br>'1'= Ready<br>'2'= Ident<br>'3'= Standby<br>'4'= Send<br>'5'= Data<br>'6'= Receive | The state of the state machine in the card when the command is received. If the execution of a command results in a change of state, this change will be reflected in the response of the next command. These four bits are interpreted as decimal numbers 0 to 15.                                  | B               |

| Bits | Identifier                                 | Type | Value  | Description   | Clear condition |
|------|--|------|--|---|-----------------|
|      |  |      | '7'= Program<br>'8'= Disconnect<br>'9'= Busy test<br>'10~15'= Reserved |   |                 |
| 8    | READY_FOR_DATA                             | SR   | '0'= no ready<br>'1'= ready  | Corresponds to a buffer empty signal on the bus.  |                 |
| 7    | SWITCH_ERROR                               | ER   | '0'=no error<br>'1'=error  | The card did not switch to the desired mode as required by the SWITCH command.            | B               |
| 6    | Reserved                                   |      |  |   |                 |
| 5    | APP_CMD                                    | SR   | '0'=enabled<br>'1'=disabled  | Card expects ACMD, or indicates that the command has been interpreted as an ACMD command. | C               |
| 4    | Reserved for SD I/O Card                   |      |  |   |                 |
| 3    | AKE_SEQ_ERROR                              | ER   | '0'=no error<br>'1'=error  | The order of validation is wrong.   | C               |
| 2    | Reserved for application specific commands |      |  |   |                 |
| 1,0  | Reserved for manufacturer test mode        |      |  |   |                 |

The abbreviations in the table for types and clearing condition fields are defined as follows:

Type:

- E: Error bit. Send an error condition to the host. These bits are cleared once a response (reporting an error) is issued.
- S: Status bit. These bits serve only as information fields and do not change in response to commands. These bits are persistent, they are set or cleared depending on the card state.
- R/X: Both R and X are detection bits, the difference is that R means that the card detects an anomaly in the command interpretation and verification phase (response mode), while X means that the card detects an anomaly in the command execution phase (execution mode).

SDIO card host can read these bits by sending a status command to query the status of the card.

Clear condition:

- A: According to the current state of the card
- B: Always relative to the previous command. Cleared when the correct command is received, this method has a delay of one command.
- C: Read clear

### 18.4.11.2 SD status register

The SD status contains not only status bits related to specific functions of the SD memory card, but also some status bits related to future applications. The length of the SD state is a 512-bit data block. After receiving the ACMD13 command (CMD55, then CMD13), the content of the SD status register is transferred to the SDIO card host. But it

should be noted that ACMD13 commands can only be sent when the card is in the transmitting state (the card has been selected).

Table 18-8 defines the different SD status register information.

Table 18-8 SD Status

| Bits    | Identifier             | Type | Value   | Description  | Clear condition |
|---------|------------------------|------|---|--|-----------------|
| 511:510 | DAT_BUS_WIDTH          | SR   | '00'= 1 (Default)<br>'01'= Reserved<br>'10'= 4 Bit width<br>'11'= Reserved  | The current data bus width as defined by the SET_BUS_WIDTH command.  | A               |
| 509     | SECURED_MODE           | SR   | '0'= Not in privacy mode<br>'1'= In privacy mode  | The card is in secure operation mode (see "SD Security Specification" for details).  | A               |
| 508:496 | Reserved               |      |   |  |                 |
| 495:480 | SD_CARD_TYPE           | SR   | '00xxh'= SD memory card in physical specification version 1.01~2.00 ('x' means any value). The defined cards are:<br>'0000'= Regular SD RD/WR Card<br>'0001'= SD ROM Card | The lower 8 bits of this field can define different variants of SD memory cards in the future (each bit can be used to define a different SD type). The upper 8 bits can be used to define SD cards that do not adhere to the current SD physical layer specification. | A               |
| 479:448 | SIZE_OF_PROTECTED_AREA | SR   | Protected area size (See below)   | (See below)  | A               |
| 447:440 | SPEED_CLASS            | SR   | The speed type of the card (See below)  | (See below)  | A               |
| 439:432 | PERFORMANCE_MOVE       | SR   | Transfer performance in units of 1MB/sec (See below)  | (See below)  | A               |
| 431:428 | AU_SIZE                | SR   | Size of AU (see below)  | (See below)  | A               |
| 427:424 | Reserved               |      |   |  |                 |
| 423:408 | ERASE_SIZE             | SR   | Number of AUs that can be erased at one time  | (See below)  | A               |
| 407:402 | ERASE_TIMEOUT          | SR   | Timeout value for the range specified by the ERASE_AU   | (See below)  | A               |

| Bits    | Identifier                | Type | Value                                       | Description | Clear condition |
|---------|---------------------------|------|---|-------------|-----------------|
|         |                           |      | unit  |             |                 |
| 401:400 | ERASE_OFFSET              | SR   | Fixed offset value to increase when erasing | (See below) | A               |
| 399:312 | Reserved                  |      |   |             |                 |
| 311:0   | Reserved for Manufacturer |      |   |             |                 |

The abbreviations in the table for types and clearing condition fields are defined as follows:

Type:

- E: Error bit. Send an error condition to the host. These bits are cleared once a response (reporting an error) is issued.
- S: Status bit. These bits serve only as information fields and do not change in response to commands. These bits are persistent, they are set or cleared depending on the card state.
- R/X: R and X are both detection bits, the difference is that R indicates that the card detects an abnormality in the command interpretation and verification stage (response mode), while X indicates that the card detects an anomaly in the command execution stage (execution mode).

The SDIO card host queries the status of the card by sending status commands to read these bits.

Clear condition:

- A: According to the current state of the card
- B: Always relative to the previous command. Cleared when the correct command is received, this method has a delay of one command.
- C: Read clear

### SIZE\_OF\_PROTECTED\_AREA

This bit is set differently for standard-capacity and high-capacity cards.

The capacity of the protected area of a standard capacity card is calculated as follows:

$$\text{Protected Area} = \text{SIZE\_OF\_PROTECTED\_AREA} * \text{MULT} * \text{BLOCK\_LEN}$$

SIZE\_OF\_PROTECTED\_AREA is in units of MULT \* BLOCK\_LEN.

The capacity of the protected area of the high-capacity card is calculated as follows:

$$\text{Protected Area} = \text{SIZE\_OF\_PROTECTED\_AREA}$$

SIZE\_OF\_PROTECTED\_AREA is in bytes.

### SPEED\_CLASS

These 8 bits indicate the type of speed and a value that can be calculated by calculating  $P_w/2$  ( $P_w$  is the write performance).

Table 18-9 Speed Type Codes

| SPEED_CLASS | Value definition |
|-------------|------------------|
|-------------|------------------|

|         |          |
|---------|----------|
| 00h     | Class 0  |
| 01h     | Class 2  |
| 02h     | Class 4  |
| 03h     | Class 6  |
| 04h~FFh | Reserved |

### PERFORMANCE\_MOVE

These 8 bits indicate the mobile performance (Pm) in units of 1MB/sec. If the card does not move data in RU (unit of record), Pm should be considered to be infinity. When this field is FFh, it means Pm is infinite.

Table 18-10 Mobility Performance Codes

| PERFORMANCE_MOVE | Value definition |
|------------------|------------------|
| 00h              | Undefined        |
| 01h              | 1MB/sec          |
| 02h              | 2MB/sec          |
| .....            | .....            |
| FEh              | 254MB/sec        |
| FFh              | Infinity         |

### AU\_SIZE

These 4 bits indicate the length of the AU, value is  $(16K \text{ bytes}) \times 2^{(AU\_SIZE-1)}$ .

Table 18-11 AU\_SIZE Codes

| AU_SIZE | Value definition |
|---------|------------------|
| 00h     | Undefined        |
| 01h     | 16KB             |
| 02h     | 32KB             |
| 03h     | 64KB             |
| 04h     | 128KB            |
| 05h     | 256KB            |
| 06h     | 512KB            |
| 07h     | 1MB              |
| 08h     | 2MB              |
| 09h     | 4MB              |
| Ah~Fh   | Reserved         |

The maximum AU length is determined by the capacity of the card. The card can set any AU length between the RU length and the maximum AU length.

Table 18-12 Maximum AU Size

|                 |           |             |       |          |
|-----------------|-----------|-------------|-------|----------|
| Capacity        | 16MB~64MB | 128MB~256MB | 512MB | 1GB~32GB |
| Maximum AU Size | 512KB     | 1MB         | 2MB   | 4MB      |

### ERASE\_SIZE

This 16-bit field represents NERASE. When NERASE AUs are erased, the timeout period is defined by

ERASE\_TIMEOUT. The host should determine the appropriate number of AUs to be erased in one operation so that the host can display the progress of the erase operation. If this field is 0, the timeout calculation for erasure is not supported.

Table 18-13 ERASE\_SIZE Codes

| ERASE_SIZE | Value definition                            |
|------------|---|
| 0000h      | Erase timeout calculation is not supported. |
| 0001h      | 1 AU  |
| 0002h      | 2 AU  |
| 0003h      | 3 AU  |
| .....      | .....                                       |
| FFFFh      | 65535 AU                                    |

## ERASE\_TIMEOUT

These 6 bits represent TERASE. When multiple AUs indicated by ERASE\_SIZE are erased, this value gives the erase timeout time from the offset. The range of ERASE\_TIMEOUT can be defined up to 63 seconds. The manufacturer of the card can choose any combination of ERASE\_SIZE and ERASE\_TIMEOUT according to the specific implementation. Once ERASE\_TIMEOUT is determined, then ERASE\_SIZE is also determined. If the ERASE\_SIZE field is set to 0, then ERASE\_TIMEOUT should also be set is 0.

Table 18-14 Erase Timeout Code

| ERASE_TIMEOUT | Value definition                            |
|---------------|---|
| 00            | Erase timeout calculation is not supported. |
| 01            | 1 sec                                       |
| 02            | 2 sec                                       |
| 03            | 3 sec                                       |
| .....         | .....                                       |
| 63            | 63 sec                                      |

## ERASE\_OFFSET

These 2 bits give TOFFSET, which can select one of the four values shown in the table below. When ERASE\_SIZE and ERASE\_TIMEOUT are both 0, this value has no meaning.

Table 18-15 Erase Offset Codes

| ERASE_OFFSET | Value definition |
|--------------|------------------|
| 0            | 0 sec            |
| 1            | 1 sec            |
| 2            | 2 sec            |
| 3            | 3 sec            |

## 18.4.12 SD I/O mode

### 18.4.12.1 I/O interrupts

There is a pin (pin 8) with interrupt function on the SD interface, which enables the SD I/O card to interrupt the multi-media card/SD module. In 4-bit SD mode, this pin is SDIO\_DAT1, through which the card sends the multi-

media card to the multi-media card. The /SD module makes an interrupt request. For each card or function within the card, the interrupt function is optional.

The interrupt of SD I/O is level-effective, that is, the interrupt signal line must maintain the active level (low) before it can be recognized and responded by the multimedia card/SD module, and remains inactive level (high) after the interrupt process ends. After the interrupt request has been serviced by the MultiMediaCard/SD module, the interrupt status bits can be cleared by writing the appropriate bits to the SD I/O card's internal registers through an I/O write operation.

The interrupt outputs of the SD I/O card are all active low, and the multimedia card/SD module provides pull-up resistors on all data lines (SDIO/D[3:0]). The multimedia card/SD module samples the 8th pin (SDIO\_DAT/IRQ) and performs interrupt detection only in the interrupt stage, and ignores the value on the signal line at other times.

Both I/O operations and memory operations have interrupt stages, and the definition of the interrupt stage for single data block operations and multiple data block transfer operations is different.

### **18.4.12.2 I/O suspend and resume**

In a multifunction SD I/O card, or in a card with both I/O and memory functions, multiple devices (I/O and memory) share the MMC/SD bus. In order to enable multiple devices to share the bus in the MMC/SD module, SD I/O cards and composite cards can selectively implement the concept of suspend/resume; in cards that support suspend/resume, the MMC/SD module can suspend a data transfer operation of a function or memory to give up the bus to another function or memory with a higher priority, and resume the previously suspended transfer after the transfer of the function or memory with a higher priority is completed.

Whether to support suspend/resume operations is optional. Following are the steps to perform a suspend/resume operation on the MMC/SD bus:

1. Determine the current function of the data line (SDIO\_DAT[3:0])
2. Request to suspend low-priority or slow operations
3. Wait for the pause operation to complete and confirm that the device has been paused
4. Start the transfer of the high-priority device
5. Wait for the high-priority device to complete the transfer
6. Resume from a suspend operation

### **18.4.12.3 I/O ReadWait**

The Read Wait operation is optional and only works in 1-bit or 4-bit mode of the SD card. The read wait operation means that when a card is reading multiple registers (IO\_RW\_EXTENDED, CMD53), the MMC/SD module can ask it to temporarily stop data transmission, and at the same time allow the MMC/SD module to send commands to other functions in the SD I/O device. The MMC/SD module can judge whether a card supports the read waiting protocol by detecting the internal registers of the card. The read wait time is related to the interrupt phase.

## **18.5 Commands and responses**

### **18.5.1 Application related commands and general commands**

The SD card host module system is a standard interface, which is suitable for a variety of application types, while

taking into account specific users and applications, so two types of general commands are defined in the standard: application-related commands (ACMD) and general commands (GEN\_CMD) .

When the card receives the APP\_CMD (CMD55) command, the card expects the next command to be an application related command. Application Dependent Commands (ACMD) and normal multimedia card commands have the same format structure, and they can also use the same CMD number. Because it appears after APP\_CMD (CMD55), the card recognizes it as an ACMD command. If the APP\_CMD(CMD55) command is not followed by a defined application-related command, it is recognized as a standard command; for example: if CMD13 (SD\_STATUS(ACMD13) is defined in the application) is received immediately after APP\_CMD(CMD55), it will be interpreted as SD\_STATUS (ACMD13); but if the card receives CMD7 immediately after APP\_CMD (CMD55), and the card does not define ACMD7, it will be interpreted as a standard CMD7 (SELECT/DESELECT\_CARD) command.

If you want to use the manufacturer-defined ACMD, the SD card host needs to do the following:

1. Send APP\_CMD (CMD55) command
2. The card returns a response to the multimedia/SD card module, indicating that the APP\_CMD bit is set and waiting for the ACMD command.
3. Send the specified ACMD
4. The card returns a response to the multimedia/SD card module, the response indicates that the APP\_CMD bit is set, and the received command has been correctly parsed according to the ACMD command; if the received command is not an ACMD command, the card will be processed according to the ordinary multimedia card command, At the same time, clear the APP\_CMD bit of the status register.

If an illegal command is sent, error handling will be performed according to standard illegal multimedia card commands. The bus operation process of the GEN\_CMD command is the same as the single data block read and write command (WRITE\_BLOCK, CMD24 or READ\_SINGLE\_BLOCK, CMD17); at this time, the parameter of the command indicates the direction of data transmission instead of the address, and the data block has a user-defined format and meaning.

Before sending the GEN\_CMD (CMD56) command, the state machine must be in the transmission state, that is, the card must be selected, and the length of the data block is defined by SET\_BLOCKLEN (CMD16). The response to the GEN\_CMD (CMD56) command is in R1b format.

## 18.5.2 Commands of Multimedia Card/SD Card module

Table 18-16 Write commands for block-based transfers

| CMD Index | Type | Parameter                             | Response Format | Abbreviation         | Description   |
|-----------|------|---------------------------------------|-----------------|----------------------|---|
| CMD23     | ac   | [31:16]=0<br>[15:0]= Number of blocks | R1              | SET_BLOCK_COUNT      | Defines the number of blocks that need to be transferred in a subsequent multi-block read or write command. |
| CMD24     | adtc | [31:0]= Data Address                  | R1              | WRITE_BLOCK          | Writes a block of the length selected by the SET_BLOCKLEN command.  |
| CMD25     | adtc | [31:0]= Data Address                  | R1              | WRITE_MULTIPLE_BLOCK | Continuously write data blocks until a STOP_TRANSMISSION command is   |

| <b>CMD Index</b> | <b>Type</b> | <b>Parameter</b>                     | <b>Response Format</b> | <b>Abbreviation</b> | <b>Description</b>   |
|------------------|-------------|--------------------------------------|------------------------|---------------------|--|
|                  |             |                                      |                        |                     | received or the specified number of blocks is reached.   |
| CMD26            | adtc        | [31:0]= Stuff bits                   | R1                     | PROGRAM_CID         | Program the identification register of the card. This command can only be sent once per card. There are hardware mechanisms in the card to prevent multiple programming operations. Usually this order is reserved for the manufacturer. |
| CMD27            | adtc        | [31:0]= Stuff bits                   | R1                     | PROGRAM_CSD         | Program the programmable bits in the CSD of the card.  |
| CMD28            | ac          | [31:0]= Data Address                 | R1b                    | SET_WRITE_PROT      | If the card is write-protected, this command sets the write-protect bit of the specified group. The write protection feature is set in the special data area of the card (WP_GRP_SIZE).  |
| CMD29            | ac          | [31:0]= Data Address                 | R1b                    | CLR_WRITE_PROT      | If the card is write-protected, this command clears the write-protect bit of the specified group.  |
| CMD30            | adtc        | [31:0]= Write Protect Data Addresses | R1                     | SEND_WRITE_PROT     | If the card is write-protected, this command requires the card to send the status of the write-protect bit.  |
| CMD31            | Reserved    |                                      |                        |                     |  |

Table 18-17 Block-based write-protect commands

| <b>CMD Index</b> | <b>Type</b> | <b>Parameter</b>                     | <b>Response Format</b> | <b>Abbreviation</b> | <b>Description</b>  |
|------------------|-------------|--------------------------------------|------------------------|---------------------|---|
| CMD28            | ac          | [31:0]= Data Address                 | R1b                    | SET_WRITE_PROT      | If the card is write-protected, this command sets the write-protect bit of the specified group. The write protection feature is set in the special data area of the card (WP_GRP_SIZE). |
| CMD29            | ac          | [31:0]= Data Address                 | R1b                    | CLR_WRITE_PROT      | If the card is write-protected, this command clears the write-protect bit of the specified group.   |
| CMD30            | adtc        | [31:0]= Write Protect Data Addresses | R1                     | SEND_WRITE_PROT     | If the card is write-protected, this command requires the card to send the status of the write-protect bit.   |
| CMD31            | Reserved    |                                      |                        |                     |   |

Table 18-18 Erase command

| CMD Index               | Type | Parameter            | Response Format | Abbreviation      | Description   |
|-------------------------|------|----------------------|-----------------|-------------------|---|
| CMD32<br>.....<br>CMD34 |      |                      |                 |                   | Reserve. For backward compatibility with older versions of the media card protocol, these command codes cannot be used. |
| CMD35                   | ac   | [31:0]= Data Address | R1              | ERASE_GROUP_START | Within the selected erase range, set the address of the first erase group.  |
| CMD36                   | ac   | [31:0]= Data Address | R1              | ERASE_GROUP_END   | Sets the address of the last erase group within the selected contiguous erase range.                                    |
| CMD37                   |      |                      |                 |                   | Reserve. For backward compatibility with older versions of the media card protocol, these command codes cannot be used. |
| CMD38                   | ac   | 31:0]= Stuff bits    | R1              | ERASE             | Erase the previously selected block of data.  |

Table 18-19 I/O mode command

| CMD Index | Type | Parameter   | Response Format | Abbreviation | Description   |
|-----------|------|---|-----------------|--------------|---|
| CMD39     | ac   | [31:16] =RCA<br>[15]= Register Write Flag<br>[14:8]= Register Address<br>[7:0]= Register Data | R4              | FAST_IO      | Used to write and read 8-bit (register) data fields. This command specifies a card and register and also provides written data if the write flag is set. The R4 response contains the data read from the specified register. This command accesses application-related registers not defined in the multimedia card standard. |
| CMD40     | bcr  | [31:0]= Data Address  | R5              | GO_IRQ_STATE | Put the system in interrupt mode.   |
| CMD41     |      |   |                 |              | Reserved  |

Table 18-20 Lock command

| CMD Index               | Type | Parameter          | Response Format | Abbreviation | Description  |
|-------------------------|------|--------------------|-----------------|--------------|--|
| CMD42                   | adtc | [31:0]= Stuff bits | R1b             | LOCK_UNLOCK  | Set/clear password or lock/unlock card. The length of the data block is set by the SET_BLOCKLEN command. |
| CMD43<br>.....<br>CMD54 |      |                    |                 |              | Reserved   |

Table 18-21 Application related commands

| CMD Index | Type | Parameter   | Response Format | Abbreviation | Description                                       |
|-----------|------|-------------|-----------------|--------------|---|
| CMD55     | ac   | [31:16]=RCA | R1              | APP_CMD      | Indicates that the next command to the card is an |

| CMD Index               | Type                       | Parameter                       | Response Format | Abbreviation | Description  |
|-------------------------|----------------------------|---------------------------------|-----------------|--------------|--|
|                         |                            | [15:0]= Stuff bits              |                 |              | application-related command rather than a standard command.  |
| CMD56                   | adtc                       | [31:1]= Stuff bits<br>[0]=RD/WR |                 |              | In general or application-related commands, either to transfer a block of data to the card, or to read a block of data from the card. The length of the data block is set by the SET_BLOCKLEN command. |
| CMD57<br>.....<br>CMD59 | Reserved                   |                                 |                 |              |  |
| CMD60<br>.....<br>CMD63 | Reserved for manufacturer. |                                 |                 |              |  |

### 18.5.3 Command type

ACMD and GEN\_CMD contain four different types:

1. Broadcast Command (BC): Sent to all cards, no response.
2. Broadcast Command with Response (BCR): sent to all cards and received responses from all cards at the same time;
3. Command (AC) with addressing (point-to-point): sent to the addressed card, there is no data transmission on the SDIO\_DAT signal line.

Data transfer command (AC) with addressing (point-to-point): sent to the addressed card, SDIO\_DAT signal line for data transfer.

### 18.5.4 Command format

The command format consists of command and response.

**Command:** A command is used to start an operation. The host sends a command with an address or a broadcast command to a specified card or all cards (the broadcast command is only applicable to MMC V3.31 or earlier versions). All commands have a fixed length of 48 bits and are transmitted serially on the CMD line. The following table gives the general command format on Multimedia Cards, SD Memory Cards and SDIO Cards

The CE-ATA command is an extension of the MMC V4.2 command, so it has the same format.

The command channel operates in half-duplex mode, so that commands and responses can be sent and received separately. If the CPSM is not in the transmit state, the SDIO\_CMD output is in a high-impedance state, as shown in Figure 20-11 Bit sequence. Data on SDIO\_CMD is synchronized with the rising edge of SDIO\_CLK.

Table 18-22 Command format

| Bit | Width | Value | Description      |
|-----|-------|-------|------------------|
| 47  | 1     | 0     | Start bit        |
| 46  | 1     | 1     | Transmission bit |

|         |    |   |               |
|---------|----|---|---------------|
| [45:40] | 6  | - | Command index |
| [39:8]  | 32 | - | Parameter     |
| [7:1]   | 7  | - | CRC7          |
| 0       | 1  | 1 | End bit       |

**Response:** The response is a response to the previously received command, which is sent to the host by a card with a specified address. For all cards of MMC V3.31 or earlier, the response is sent simultaneously; the response is serially transmitted on the SDIO\_CMD line.

SDIO supports two response types: 48-bit short response and 136-bit long response. Both types have CRC error detection:

*Note: If the response does not contain a CRC (such as the response to CMD1), the device driver SHOULD ignore the CRC failure status.*

Table 18-23 Short response format

| Bit     | Width | Value | Description        |
|---------|-------|-------|--------------------|
| 47      | 1     | 0     | Start bit          |
| 46      | 1     | 0     | Transmission bit   |
| [45:40] | 6     | -     | Command index      |
| [39:8]  | 32    | -     | Parameter          |
| [7:1]   | 7     | -     | CRC7 (or 1111111b) |
| 0       | 1     | 1     | End bit            |

Table 18-24 Long response format

| Bit       | Width | Value  | Description                          |
|-----------|-------|--------|--------------------------------------|
| 135       | 1     | 0      | Start bit                            |
| 134       | 1     | 0      | Transmission bit                     |
| [133:128] | 6     | 111111 | Reserved                             |
| [127:1]   | 127   | -      | CID or CSD (including internal CRC7) |
| 0         | 1     | 1      | End bit                              |

## 18.5.5 Response format

All responses are sent over the CMD signal line. Response transfers always start with the MSB bit of the corresponding response string. The length of the response string depends on the response type.

Each response contains a start bit (always 0) followed by the direction bit of the transfer (card=0). The x in the table below represents a variable part. All responses are CRC protected except for the R3 response type. Each command codeword has an end bit (always 1).

There are 5 response types, and their formats are defined as follows:

### R1 (normal response command)

The code length of the R1 response is 48 bits. Where bits 45:40 indicate the command index to respond to and its value is between 0 and 63. The state of the card is encoded by 32 bits.

Table 18-25 R1 response

| Bit     | Width | Value | Description      |
|---------|-------|-------|------------------|
| 47      | 1     | 0     | Start bit        |
| 46      | 1     | 0     | Transmission bit |
| [45:40] | 6     | X     | Command index    |
| [39:8]  | 32    | X     | Card status      |
| [7:1]   | 7     | X     | CRC7             |
| 0       | 1     | 1     | End bit          |

### R1b

R1b has the same format as R1, the difference is that R1b can choose to send a busy signal on the data line. After receiving these commands, depending on the state before receiving the command, the card may become busy and the host should check the busy state in the response.

### R2 (CID, CSD register)

The R2 code length is 136 bits. The responses of CMD2 and CMD10 are saved in the CID register and sent. The response of CMD9 is saved in the CSD register and sent. The card only responds and transmits bits [127...1] of CID and CSD, on the receiving side, these two register reserved bits [0] are replaced with the end bit of the response. The actual erase operation may take a long time, and the host can send a CMD7 command to deselect the card.

Table 18-26 R2 response

| Bit       | Width | Value    | Description      |
|-----------|-------|----------|------------------|
| 135       | 1     | 0        | Start bit        |
| 134       | 1     | 0        | Transmission bit |
| [133:128] | 6     | '111111' | Command index    |
| [127:1]   | 127   | X        | Card status      |
| 0         | 1     | 1        | End bit          |

### R3 (OCR register)

The R3 code length is 48 bits. The response of CMD1 is saved in the OCR register and sent. The definition of the level code is: the limited voltage window is low and the card is busy.

Table 18-27 R3 response

| Bit     | Width | Value     | Description      |
|---------|-------|-----------|------------------|
| 47      | 1     | 0         | Start bit        |
| 46      | 1     | 0         | Transmission bit |
| [45:40] | 6     | '111111'  | Reserved         |
| [39:8]  | 32    | X         | OCR register     |
| [7:1]   | 7     | '1111111' | Reserved         |
| 0       | 1     | 1         | End bit          |

### R4 (Fast I/O)

The R4 code is 48 bits long and is only applicable to MMC cards. The parameter field includes the RCA of the specified card, the address of the register that needs to be read or written, and its content.

Table 18-28 R4 response

| Bit                  | Width   | Value     | Description      |                        |
|----------------------|---------|-----------|------------------|------------------------|
| 47                   | 1       | 0         | Start bit        |                        |
| 46                   | 1       | 0         | Transmission bit |                        |
| [45:40]              | 6       | '111111'  | Reserved         |                        |
| [39:8]Argument field | [31:16] | 16        | x                | RCA                    |
|                      | [15:8]  | 8         | x                | Register address       |
|                      | [7:0]   | 8         | x                | Read register contents |
| [7:1]                | 7       | '1111111' | CRC7             |                        |
| 0                    | 1       |           | End bit          |                        |

### R4b

R4b is only available for SD I/O cards, and the code length is 48 bits. The SDIO card will return a unique SDIO response R4 after receiving the CMD5 command.

Table 18-29 R4b response

| Bit                  | Width   | Value | Description      |                         |
|----------------------|---------|-------|------------------|-------------------------|
| 47                   | 1       | 0     | Start bit        |                         |
| 46                   | 1       | 0     | Transmission bit |                         |
| [45:40]              | 6       | x     | Reserved         |                         |
| [39:8]Argument field | 39      | 1     | x                | Card is ready           |
|                      | [38:36] | 3     | x                | Number of I/O functions |
|                      | 35      | 1     | x                | Present memory          |
|                      | [34:32] | 3     | x                | Stuff bits              |
|                      | [31:8]  | 24    | x                | I/O ORC                 |
| [7:1]                | 7       | x'    | Reserved         |                         |
| 0                    | 1       | 1     | End bit          |                         |

When the SD I/O card receives the command CMD5, the I/O part of the card is enabled and can respond to all subsequent commands normally. The enabled state of the I/O card will remain until the next reset, power off, or CMD52 command for I/O reset. Note that the correct response for a memory-only SD card would be 1 for the current memory and 0 for the number of I/O functions. A memory-only SD card designed according to the SD Memory Card Specification Version 1.0 treats the detected CMD5 command as an illegal command and does not respond to it. The host that can handle the I/O card will send a CMD5 command, and if the card returns a response R4, the host will determine the configuration of the card based on the data in the R4 response.

### R5 (Interrupt Request)

R5 only works with multimedia cards. The code length is 48 bits. The RCA field in the parameter is 0x0 when this response is generated by the host.

Table 18-30 R5 response

| Bit     | Width | Value    | Description      |
|---------|-------|----------|------------------|
| 47      | 1     | 0        | Start bit        |
| 46      | 1     | 0        | Transmission bit |
| [45:40] | 6     | '111111' | CMD40            |

| Bit                  |         | Width | Value | Description                               |
|----------------------|---------|-------|-------|---|
| [39:8]Argument field | [31:16] | 16    | x     | RCA[31:16] of a successful card or host   |
|                      | [15:0]  | 16    | x     | Undefined. Can be used as interrupt data. |
| [7:1]                |         | 7     | x     | CRC7                                      |
| 0                    |         | 1     | 1     | End bit                                   |

## R6 (Interrupt Request)

R6 only works with SD I/O cards. The code length is 48 bits. Bits[45:40] represent the command index to the CMD3 response. The 16 most significant bits of the parameter field are used for the published RCA number. This is the normal response of the memory device to a CMD3 command.

Table 18-31 R6 response

| Bit                  |         | Width | Value    | Description                               |
|----------------------|---------|-------|----------|---|
| 47                   |         | 1     | 0        | Start bit                                 |
| 46                   |         | 1     | 0        | Transmission bit                          |
| [45:40]              |         | 6     | '101000' | CMD40                                     |
| [39:8]Argument field | [31:16] | 16    | x        | RCA[31:16] of a successful card or host   |
|                      | [15:0]  | 16    | x        | Undefined. Can be used as interrupt data. |
| [7:1]                |         | 7     | x        | CRC7                                      |
| 0                    |         | 1     | 1        | End bit                                   |

When sending a CMD3 command to an I/O-only card, the card's status bits[23:8] will change, and bit 16 in the response is the value in the I/O-only SD card, bit 15 is COM\_CRC\_ERROR, Bit 14 is ILLEGAL\_COMMAND, Bit 13 is ERROR, Bits[12:0] are reserved.

## 18.6 Hardware flow control

Using the hardware flow control function can avoid FIFO underflow (transmit mode) and overflow (receive mode) errors.

The operation process of hardware flow control is to stop SDIO\_CLK and freeze the SDIO state machine. When the FIFO cannot send and receive data, the data transmission is suspended. It should be noted that only the state machine driven by SDIO\_CLK is frozen, the AHB interface is still working. Even when flow control is in effect, the FIFO can still be read from or written to.

The SDIO\_CLKCTRL.HWCLKEN bit must be set to '1' to enable hardware flow control. After reset, the hardware flow control function is automatically turned off.

## 18.7 SDIO register

Devices communicate with the system through control registers. The width of the control registers is 32 bits wide, and these registers can be manipulated on the AHB bus. Note that these peripheral registers must be manipulated in word (32 bits).



## 18.7.2 SDIO power control register (SDIO\_PWRCTRL)

Address offset: 0x00

Reset value: 0x0000 0000

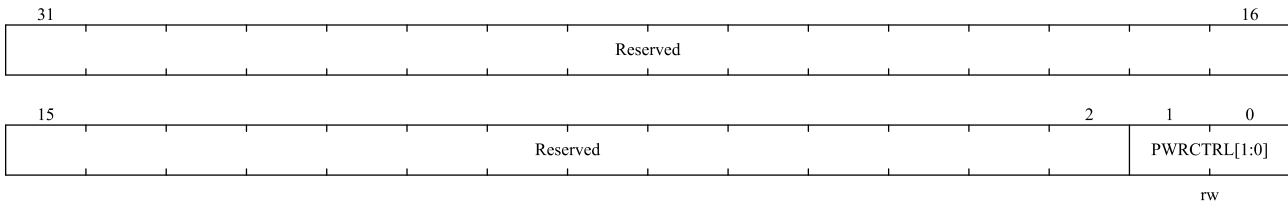

| Bit Field | Name     | Description   |
|-----------|----------|---|
| 31:2      | Reserved | Reserved, the reset value must be maintained.   |
| 1:0       | PWRCTRL  | Power supply control bits.<br>Defines the current functional state of the card clock:<br>00: The power is turned off and the clock of the card is stopped.<br>01: Reserved.<br>10: Reserved, power-on state.<br>11: Power-on state, the clock of the card is turned on. |

Note: This register cannot be written within 7 HCLK clock cycles after writing data.

## 18.7.3 SDIO clock control register (SDIO\_CLKCTRL)

Address offset: 0x04

Reset value: 0x0000 0000

SDIO\_CLKCTRL register controls the SDIO\_CLK output clock.

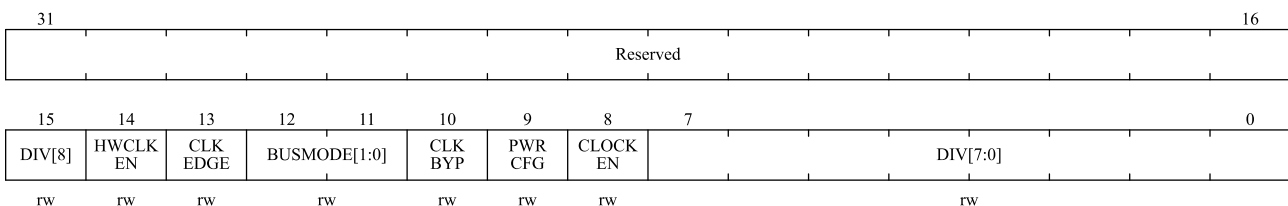

| Bit Field | Name     | Description   |
|-----------|----------|---|
| 31:16     | Reserved | Reserved, the reset value must be maintained.   |
| 15        | DIV[8]   | The highest bit of the clock frequency division factor, used in extended mode.  |
| 14        | HWCLKEN  | HW Flow Control enable.<br>0: Disable hardware flow control<br>1: Enable hardware flow control<br>After hardware flow control is enabled, please refer to the definition of SDIO status register in Section 0 for the meaning of SDIO_STS.TFIFOE and SDIO_STS.RFIFOE interrupt signals. |
| 13        | CLKEDGE  | SDIO_CLK dephasing selection bit.<br>0: SDIO_CLK is generated on the rising edge of the master clock SDIOCLK.   |

| Bit Field | Name    | Description  |
|-----------|---------|--|
|           |         | 1: SDIO_CLK is generated on the falling edge of the master clock SDIOCLK.  |
| 12:11     | BUSMODE | Wide bus mode enable bit.<br>00: Default bus mode, use SDIO_DAT0.<br>01: 4-bit bus mode, use SDIO_DAT[3:0].<br>10: 8-bit bus mode, use SDIO_DAT[7:0].  |
| 10        | CLKBYP  | Clock divider bypass enable bit.<br>0: Bypass off: SDIOCLK is divided according to the DIV value before driving the SDIO_CLK output signal.<br>1: Bypass enabled: SDIOCLK directly drives the SDIO_CLK output signal.                    |
| 9         | PWRCFG  | Power saving configuration bit.<br>To save power, the SDIO_CLK clock output can be turned off by setting the PWRCFG bit when the bus is idle.<br>0: SDIO_CLK is always output.<br>1: SDIO_CLK is only output when there is bus activity. |
| 8         | CLOCKEN | Clock enable bit.<br>0: SDIO_CLK is off.<br>1: SDIO_CLK is enabled.  |
| 7:0       | DIV     | Clock divide factor.<br>This field defines the division factor between the input clock (SDIOCLK) and the output clock (SDIO_CLK):<br>SDIO_CLK frequency = SDIOCLK/[DIV + 2].   |

*Notice:*

1. When SD/SDIO card or multimedia card is in identification mode, the frequency of SDIO\_CLK must be lower than 400kHz.
2. When all cards are assigned corresponding addresses, the clock frequency can be changed to the maximum frequency allowed by the card bus.
3. This register cannot be written within 7 HCLK clock cycles after writing data. For SD I/O cards, SDIO\_CLK can be stopped during the read wait period, when SDIO\_CLKCTRL register does not control SDIO\_CLK.

### 18.7.4 SDIO command argument register (SDIO\_CMDARG)

Address offset: 0x08

Reset value: 0x0000 0000

SDIO\_CMDARG register contains the 32-bit command parameter, which will be sent to the card as part of the command.

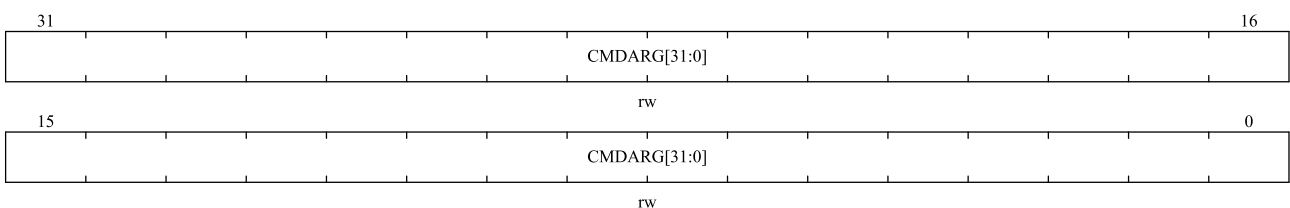

| Bit Field | Name   | Description   |
|-----------|--------|---|
| 31:0      | CMDARG | Command argument.<br>Command parameters are part of the command sent to the card. If a command contains a parameter, this register must be loaded before writing the command to the command register. |

### 18.7.5 SDIO command register (SDIO\_CMDCTRL)

Address offset: 0x0C

Reset value: 0x0000 0000

SDIO\_CMDCTRL register contains the command index and command type bits. The command index is sent to the card as part of the command. The Command Type bit controls the Command Channel State Machine (CPSM).

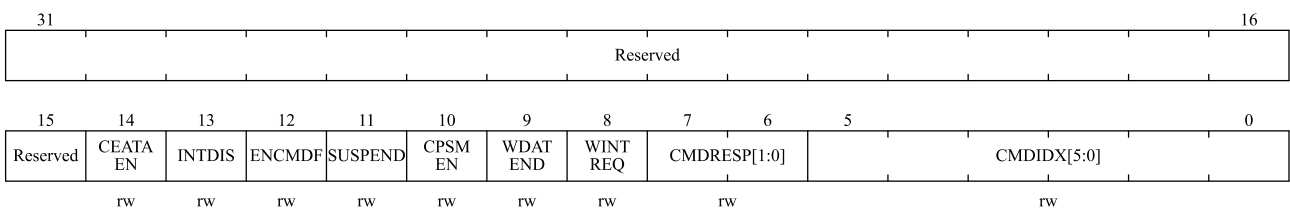

| Bit Field | Name     | Description  |
|-----------|----------|--|
| 31:15     | Reserved | Reserved, the reset value must be maintained.  |
| 14        | CEATAEN  | CE-ATA command.<br>If this bit is set, CPSM will transmit CMD61.   |
| 13        | INTDIS   | Not interrupt enable.<br>If this bit is not set, interrupts are enabled for CE-ATA devices.  |
| 12        | ENCMDF   | Enable CMD completion.<br>If this bit is set, the command complete signal is enabled.  |
| 11        | SUSPEND  | SD I/O suspend command.<br>If this bit is set, the command to be sent is a suspend command (for SDIO cards only).  |
| 10        | CPSMEN   | Command path state machine (CPSM) Enable bit.<br>If this bit is set, CPSM is enabled.  |
| 9         | WDATEND  | CPSM Waits for ends of data transfer (CmdPend internal signal).<br>If this bit is set, the CPSM waits for the end of the data transfer before starting to send a command.  |
| 8         | WINTREQ  | CPSM waits for interrupt request.<br>If this bit is set, the CPSM turns off the command timeout control and waits for an interrupt request.  |
| 7:6       | CMDRESP  | Wait for response bits.<br>These 2 bits indicate whether the CPSM needs to wait for a response, and if it needs to wait for a response, the response type.<br>00: No response, expect SDIO_STS.CMDSEND flag<br>01: Short response, expect SDIO_STS.CMDRESPRECV or SDIO_STS.CCRCERR flag<br>10: No response, expect SDIO_STS.CMDSEND flag<br>11: long response, expect SDIO_STS.CMDRESPRECV or C SDIO_STS.CRCERR flag |
| 5:0       | CMDIDX   | Command index.   |

| Bit Field | Name | Description   |
|-----------|------|---|
|           |      | The command index is sent to the card as part of the command. |

Notice:

1. This register cannot be written within 7 HCLK clock cycles after writing data.
2. The multimedia card can send 2 kinds of responses: 48-bit short response, or 136-bit long response. SD cards and SD I/O cards can only send short responses, the parameters can be changed according to the type of response, and the software will distinguish the type of response according to the command sent. CE-ATA devices only send short responses.

### 18.7.6 SDIO command response register(SDIO\_CMDRESP)

Address offset: 0x10

Reset value: 0x0000 0000

SDIO\_CMDRESP register contains the command index in the last received command response. If the transmitted command response does not contain a command index (long response or OCR response), although it should contain 111111b (reserved field value in the response), the content of the RESPCMDIDX field is unknown.

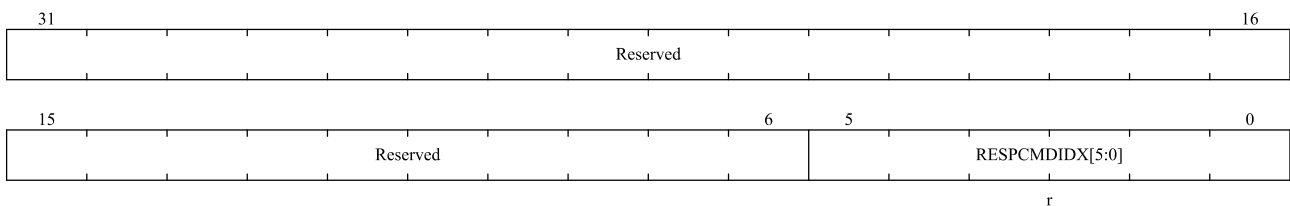

| Bit Field | Name       | Description   |
|-----------|------------|---|
| 31:6      | Reserved   | Reserved, the reset value must be maintained.   |
| 5:0       | RESPCMDIDX | Response command index.<br>Read-only bit that contains the command index in the last command response received. |

### 18.7.7 SDIO response 1..4 register (SDIO\_RESPONSEx)

Address offset:  $0x14 + 4*(x-1)$ ,  $x = 1..4$

Reset value: 0x0000 0000

SDIO\_RESPONSE1/2/3/4 registers contain the status of the card, i.e. the part of the response received.

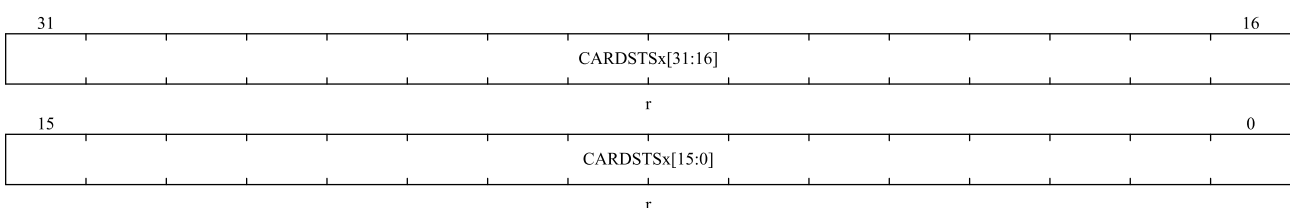

| Bit Field | Name | Description |
|-----------|------|-------------|
|-----------|------|-------------|

|      |           |                  |
|------|-----------|------------------|
| 31:0 | CARDSTSx: | See table below. |
|------|-----------|------------------|

Depending on the response status, the card's status length is either 32 bits or 127 bits.

Table 18-33 Response Type and SDIO\_RESPONSEx Register

| Register       | Short response    | Long response       |
|----------------|-------------------|---------------------|
| SDIO_RESPONSE1 | Card Status[31:0] | Card Status[127:96] |
| SDIO_RESPONSE2 | Unused            | Card Status[95:64]  |
| SDIO_RESPONSE3 | Unused            | Card Status[63:32]  |
| SDIO_RESPONSE4 | Unused            | Card Status[31:1]   |

The highest bit of the card status is always received first, and the lowest bit of the SDIO\_RESPONSE3 register is always 0.

### 18.7.8 SDIO data timer register (SDIO\_DTIMER)

Address offset: 0x24

Reset value: 0x0000 0000

SDIO\_DTIMER register contains the data timeout in card bus clock cycles.

A counter loads the value from the SDIO\_DTIMER register and counts down when the data path state machine (DPSM) enters the Wait\_R or busy state, and sets the timeout flag if the counter decrements to 0 while the DPSM is in these states.

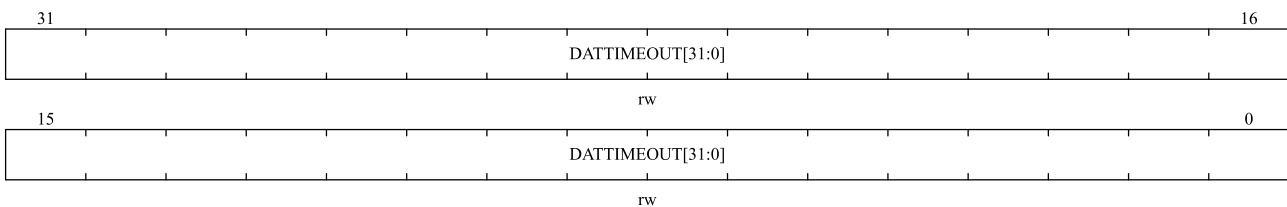

| Bit Field | Name       | Description  |
|-----------|------------|--|
| 31:0      | DATTIMEOUT | Data timeout period.<br>Data timeout in card bus clock cycles. |

*Note: Before writing to the data control register for data transfer, the data timer register and data length register must be written first.*

### 18.7.9 SDIO data length register (SDIO\_DATLEN)

Address offset: 0x28

Reset value: 0x0000 0000

SDIO\_DATLEN register contains the length of data bytes to be transferred. When data transfer starts, this value is loaded into the data counter.

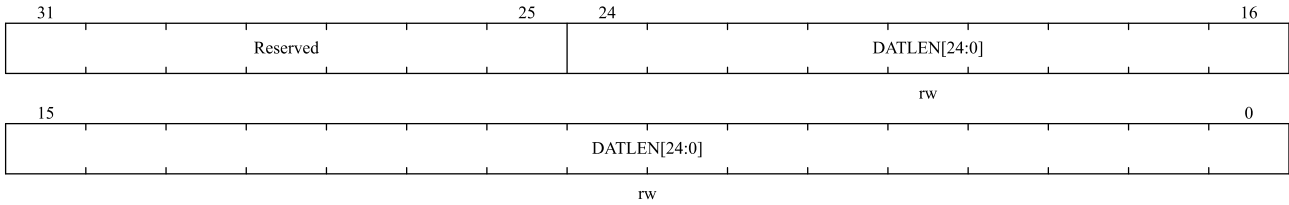

| Bit Field | Name     | Description   |
|-----------|----------|---|
| 31:25     | Reserved | Reserved, the reset value must be maintained.           |
| 24:0      | DATLEN   | Data length value.<br>Number of data bytes to transfer. |

*Note: For block data transfers, the value in the data length register must be a multiple of the data block length (see SDIO\_DATCTRL). Before writing to the data control register for data transfer, the data timer register and data length register must be written first.*

### 18.7.10 SDIO data control register (SDIO\_DATCTRL)

Address offset: 0x2C

Reset value: 0x0000 0000

SDIO\_DATCTRL register controls the Data Path State Machine (DPSM).

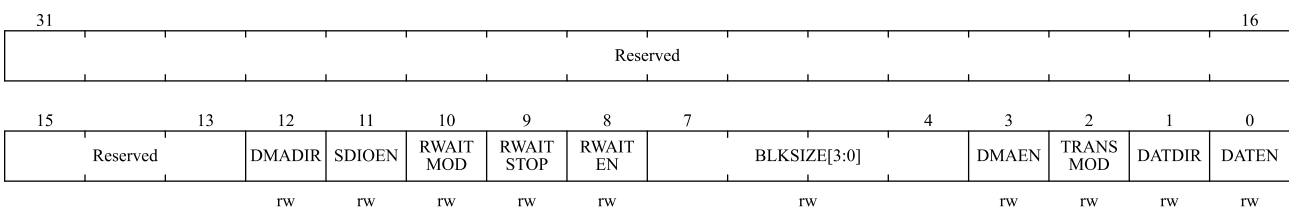

| Bit Field | Name         | Description   |
|-----------|--------------|---|
| 31:13     | Reserved     | Reserved, the reset value must be maintained.   |
| 12        | DMADIR       | In DMA mode, it is configured as 1 when data output is transferred to an external device, and configured as 0 when external device data is input. |
| 11        | SDIOEN       | SD I/O enable functions.<br>If this bit is set, the DPSM performs SD I/O card specific operations.  |
| 10        | RWAITMOD     | Read wait mode.<br>0: Stop SDIO_CLK control read wait;<br>1: Use SDIO_DAT2 to control read wait.  |
| 9         | RWAITSTOP    | Read wait stop.<br>0: If RWAITEN is set, execute read wait;<br>1: Stop read wait if RWAITEN is set.   |
| 8         | RWAITEN      | Read wait start.<br>Setting this bit starts a read wait operation.  |
| 7:4       | BLKSIZE[3:0] | Data block size.<br>When block data transfer mode is selected, this field defines the data block length:<br>0000: block length = $2^0 = 1$ byte;  |

| Bit Field | Name     | Description   |
|-----------|----------|---|
|           |          | 0001: block length = $2^1 = 2$ bytes;<br>0010: block length = $2^2 = 4$ bytes;<br>0011: block length = $2^3 = 8$ bytes;<br>0100: (decimal 4) block length= $2^4=16$ bytes;<br>0101: (decimal 5) block length= $2^5=32$ bytes;<br>0110: (decimal 6) block length = $2^6 = 64$ bytes;<br>0111: block length = $2^7 = 128$ bytes;<br>1000: block length = $2^8 = 256$ bytes;<br>1001: block length = $2^9 = 512$ bytes;<br>1010: block length = $2^{10} = 1024$ bytes;<br>1011: block length = $2^{11} = 2048$ bytes;<br>1100: block length= $2^{12}=4096$ bytes;<br>1101: block length= $2^{13}=8192$ bytes;<br>1110: block length = $2^{14} = 16384$ bytes;<br>1111: reserved. |
| 3         | DMAEN    | DMA enable bit.<br>0: Turn off DMA;<br>1: Enable DMA.   |
| 2         | TRANSMOD | Data transfer mode selection.<br>0: block data transfer;<br>1: Streaming data transmission.   |
| 1         | DATDIR   | Data transfer direction selection.<br>0: controller to card;<br>1: Card to the controller.  |
| 0         | DATEN    | Data transfer enabled bit.<br>If this bit is set to 1, data transfer starts. Depending on the DATDIR direction bit, the DPSM enters the Wait_S or Wait_R state, and if the RWAITEN bit is set at the very beginning of the transfer, the DPSM enters the read wait state. The enable bit does not need to be cleared after a data transfer, but SDIO_DATCTRL must be changed to allow a new data transfer.  |

*Note: This register cannot be written within 7 HCLK clock cycles after writing data.*

### 18.7.11 SDIO data counter register (SDIO\_DATCOUNT)

Address offset: 0x30

Reset value: 0x0000 0000

When the DPSM enters the Wait\_R or Wait\_S state from the idle state, the SDIO\_DATCOUNT register loads the value from the data length register (see SDIO\_DATLEN). During the data transfer, the value of this counter is decremented until it is reduced to 0, then the SDIO\_STS.DPSM enters the idle state and sets the data state End mark DATEND.

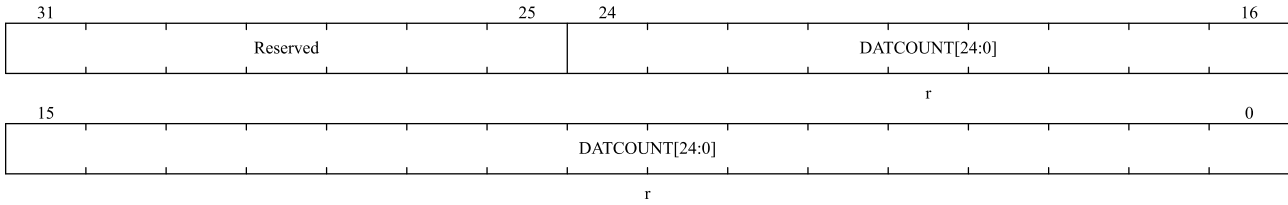

| Bit Field | Name     | Description  |
|-----------|----------|--|
| 31:25     | Reserved | Reserved, the reset value must be maintained.  |
| 24:0      | DATCOUNT | Data count value.<br>When reading this register, it returns the number of data bytes to be transmitted. Writing this register has no effect. |

*Note: This register can only be read at the end of a data transfer.*

### 18.7.12 SDIO status register (SDIO\_STS)

Address offset: 0x34

Reset value: 0x0000 0000

SDIO\_STS is a read-only register that contains two types of flags:

- Static flags (bits[23:22, 10:0]): These bits can be cleared by writing to the SDIO Interrupt Clear Register (see SDIO\_INTCLR).
- Dynamic flags (bits[21:11]): The state of these bits changes according to the part of the logic they correspond to (eg: FIFO full and empty flags go high or low with data writes to the FIFO).

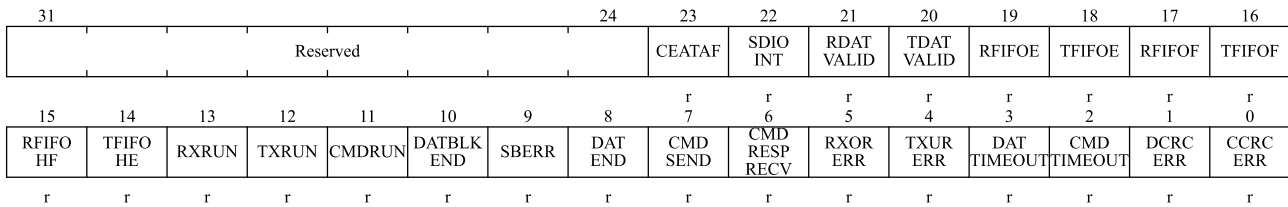

| Bit Field | Name      | Description  |
|-----------|-----------|--|
| 31:24     | Reserved  | Reserved, the reset value must be maintained.  |
| 23        | CEATAF    | CE-ATA command completion signal received for CMD61.   |
| 22        | SDIOINT   | SDIO interrupt received.   |
| 21        | RDATVALID | Data available in receive FIFO.  |
| 20        | TDATVALID | Data available in transmit FIFO.   |
| 19        | RFIFOE    | Receive FIFO empty.  |
| 18        | TFIFOE    | Transmit FIFO empty.<br>If hardware flow control is used, the TFIFOE signal becomes active when the FIFO contains 2 words.   |
| 17        | RFIFO     | Receive FIFO full.<br>If hardware flow control is used, the RFIFO signal becomes active when the FIFO is still 2 words full. |

| Bit Field | Name       | Description  |
|-----------|------------|--|
| 16        | TFIFOOF    | Transmit FIFO full.  |
| 15        | RFIFOHF    | Receive FIFO half full:<br>There are at least 8 words left in the FIFO.                        |
| 14        | TFIFOHE    | Transmit FIFO half empty:<br>At least 8 more words can be written to the FIFO.                 |
| 13        | RXRUN      | Data receive in progress.  |
| 12        | TXRUN      | Data transmit in progress.   |
| 11        | CMDRUN     | Command transfer in progress.  |
| 10        | DATBLKEND  | Data block sent/received (CRC check passed).   |
| 9         | SBERR      | Start bit not detected on all data signals in wide bus mode.                                   |
| 8         | DATEND     | Data end (Data counter, SDIDCOUNT, is zero).   |
| 7         | CMDSEND    | Command sent (no response required).   |
| 6         | CMDRESPREC | Command response (CRC check passed).   |
| 5         | RXORERR    | Received FIFO overrun error.   |
| 4         | TXURERR    | Transmit FIFO underrun error.  |
| 3         | DATTIMEOUT | Data timeout.  |
| 2         | CMDTIMEOUT | Command response timeout.<br>The command timeout is a fixed value of 64 SDIO_CLK clock cycles. |
| 1         | DCRCERR    | Data block sent/received (CRC check failed).   |
| 0         | CCRCERR    | Command response received (CRC check failed).  |

### 18.7.13 SDIO interrupt clear register (SDIO\_INTCLR)

Address offset: 0x38

Reset value: 0x0000 0000

SDIO\_INTCLR is a write-only register, writing '1' in the corresponding register bit will clear the corresponding bit in the SDIO\_STS status register.

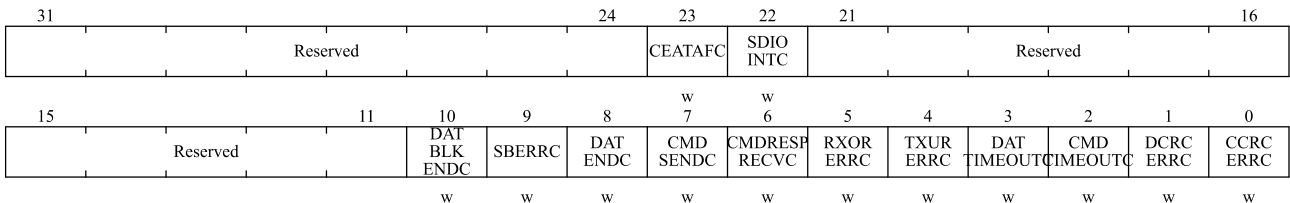

| Bit Field | Name       | Description   |
|-----------|------------|---|
| 31:24     | Reserved   | Reserved, the reset value must be maintained.   |
| 23        | CEATAFC    | CEATAF flag clear bit.<br>Software sets this bit to clear the SDIO_STS.CEATAF flag.   |
| 22        | SDIOINTC   | SDIOINT flag clear bit.<br>Software sets this bit to clear the SDIO_STS.SDIOINT flag. |
| 21:11     | Reserved   | Reserved, the reset value must be maintained.   |
| 10        | DATBLKENDC | DATBLKEND flag clear bit.   |

| Bit Field | Name        | Description   |
|-----------|-------------|---|
|           |             | Software sets this bit to clear the SDIO_STS.DATBLKEND flag.                                  |
| 9         | SBERRC      | SBERR flag clear bit.<br>Software sets this bit to clear the SDIO_STS.SBERR flag.             |
| 8         | DATENDC     | DATEND flag clear bit.<br>Software sets this bit to clear the SDIO_STS.DATEND flag.           |
| 7         | CMDSEND     | CMDSEND flag clear bit.<br>Software sets this bit to clear the SDIO_STS.CMDSEND flag.         |
| 6         | CMDRESPRECV | CMDRESPRECV flag clear bit.<br>Software sets this bit to clear the SDIO_STS.CMDRESPRECV flag. |
| 5         | RXORERRC    | RXORERR flag clear bit.<br>Software sets this bit to clear the SDIO_STS.RXORERR flag.         |
| 4         | TXURERRC    | TXURERR flag clear bit.<br>Software sets this bit to clear the SDIO_STS.TXURERR flag.         |
| 3         | DATTIMEOUTC | DATTIMEOUT flag clear bit.<br>Software sets this bit to clear the SDIO_STS.DATTIMEOUT flag.   |
| 2         | CMDTIMEOUTC | CMDTIMEOUT flag clear bit.<br>Software sets this bit to clear the SDIO_STS.CMDTIMEOUT flag.   |
| 1         | DCRCERRC    | DCRCERR flag clear bit.<br>Software sets this bit to clear the SDIO_STS.DCRCERR flag.         |
| 0         | CCRCERRC    | CCRCERR clear bit.<br>Software sets this bit to clear the SDIO_STS.CCRCERR flag.              |

### 18.7.14 SDIO interrupt enable register (SDIO\_INTEN)

Address offset: 0x3C

Reset value: 0x0000 0000

In the corresponding bit '1', the SDIO\_INTEN interrupt enable register determines which status bit generates the interrupt.

|            |            |          |          |           |              |          |           |            |                 |            |             |                |                |            |            |          |          |
|------------|------------|----------|----------|-----------|--------------|----------|-----------|------------|-----------------|------------|-------------|----------------|----------------|------------|------------|----------|----------|
| 31         |            |          |          | 24        |              |          |           | 23         | 22              | 21         | 20          | 19             | 18             | 17         | 16         |          |          |
| Reserved   |            |          |          |           |              |          |           |            |                 | CEATAF EN  | SDIO INT EN | RDAT VALID EN  | TDAT VALID EN  | RFIFOE EN  | TFIFOE EN  | RFIFO EN | TFIFO EN |
|            |            |          |          |           |              |          | rw        | rw         | rw              | rw         | rw          | rw             | rw             | rw         | rw         |          |          |
| 15         | 14         | 13       | 12       | 11        | 10           | 9        | 8         | 7          | 6               | 5          | 4           | 3              | 2              | 1          | 0          |          |          |
| RFIFO HFEN | TFIFO HEEN | RXRUN EN | TXRUN EN | CMDRUN EN | DATBLK ENDEN | SBERR EN | DAT ENDEN | CMD SENDEN | CMD RESP RECVEN | RXOR ERREN | TXUR ERREN  | DAT TIMEOUT EN | CMD TIMEOUT EN | DCRC ERREN | CCRC ERREN |          |          |
| rw         | rw         | rw       | rw       | rw        | rw           | rw       | rw        | rw         | rw              | rw         | rw          | rw             | rw             | rw         | rw         |          |          |

| Bit Field | Name     | Description   |
|-----------|----------|---|
| 31:24     | Reserved | Reserved, the reset value must be maintained.   |
| 23        | CEATAFEN | CE-ATA command completion signal received interrupt enable.<br>Setting/clearing this bit by software to enable/disable interrupt generation upon receipt of CE-ATA command completion signal.<br>0: No interrupt is generated when the CE-ATA command completion signal is received<br>1: An interrupt is generated when the CE-ATA command completion signal is received |

| Bit Field | Name        | Description  |
|-----------|-------------|--|
| 22        | SDIOINTEN   | SDIO mode interrupt received interrupt enable<br>Setting/clearing this bit by software to enable/disable the SDIO mode interrupt received interrupt function.<br>0: SDIO mode interrupt has been received and no interrupt will be generated<br>1: SDIO mode interrupt has been received and an interrupt is generated |
| 21        | RDATVALIDEN | Data available in Rx FIFO interrupt enable.<br>Setting/clearing this bit by software to enable/disable the data valid interrupt in the receive FIFO.<br>0: The data in the receiving FIFO is valid and no interrupt is generated<br>1: The data in the receiving FIFO is valid to generate an interrupt                |
| 20        | TDATVALIDEN | Data available in Rx FIFO interrupt enable.<br>Setting/clearing this bit by software to enable/disable the data valid interrupt in the transmit FIFO.<br>0: The data in the transmit FIFO is valid and no interrupt is generated<br>1: The data in the transmit FIFO is valid to generate an interrupt                 |
| 19        | RFIFOEEN    | Rx FIFO empty interrupt enable.<br>Setting/clearing this bit by software to enable/disable the data valid interrupt in the transmit FIFO.<br>0: The data in the transmit FIFO is valid and no interrupt is generated<br>1: The data in the transmit FIFO is valid to generate an interrupt                             |
| 18        | TFIFOEEN    | Tx FIFO empty interrupt enable.<br>Setting/clearing this bit by software to enable/disable the transmit FIFO empty interrupt.<br>0: No interrupt will be generated when the transmit FIFO is empty<br>1: Transmit FIFO empty and generate interrupt  |
| 17        | RFIFOEEN    | Rx FIFO full interrupt enable.<br>Setting/clearing this bit by software enables/disables the receive FIFO full interrupt.<br>0: No interrupt will be generated when the receive FIFO is full<br>1: Receive FIFO full and generate an interrupt   |
| 16        | TFIFOEEN    | Tx FIFO full interrupt enable.<br>Setting/clearing this bit by software to enable/disable the transmit FIFO full interrupt.<br>0: No interrupt will be generated when the transmit FIFO is full<br>1: Transmit FIFO full generates an interrupt  |
| 15        | RFIFOHFEN   | Rx FIFO half full interrupt enable.<br>Setting/clearing this bit by software enables/disables the receive FIFO half-full interrupt.<br>0: No interrupt is generated when the receive FIFO is half full<br>1: Interrupt generated when the receive FIFO is half full  |
| 14        | TFIFOHEEN   | Tx FIFO half empty interrupt enable.<br>Setting/clearing this bit by software to enable/disable the transmit FIFO half-empty interrupt.<br>0: No interrupt is generated when the transmit FIFO is half-empty<br>1: Transmit FIFO half empty to generate interrupt  |
| 13        | RXRUNEN     | Data receive acting interrupt enable.<br>Setting/clearing this bit by software to enable/disable the receiving data interrupt.<br>0: Data is being received without generating an interrupt<br>1: Interrupt when data is being received  |
| 12        | TXRUNEN     | Data transmit acting interrupt enable.<br>Setting/clearing this bit by software to enable/disable the Transmitting Data interrupt.   |

| Bit Field | Name          | Description  |
|-----------|---------------|--|
|           |               | 0: Data is being sent without generating an interrupt<br>1: Interrupt when data is being sent  |
| 11        | CMDRUNEN      | Command acting interrupt enable.<br>Setting/clearing this bit by software to enable/disable the command-in-transit interrupt.<br>0: Transmitting command without interrupt<br>1: Interrupt when command is being transmitted   |
| 10        | DATBLKEN      | Data block end interrupt enable.<br>Setting/clearing this bit by software enables/disables the end of block transfer interrupt.<br>0: No interrupt is generated at the end of data block transfer<br>1: Interrupt generated at the end of data block transfer                  |
| 9         | SBERREN       | Start bit error interrupt enable.<br>Setting/clearing this bit by software to enable/disable start bit error interrupt.<br>0: Start bit error does not generate an interrupt<br>1: Start bit error generates an interrupt  |
| 8         | DATENDEN      | Data end interrupt enable.<br>Set/clear this bit by software to enable/disable end of data transfer interrupt.<br>0: No interrupt will be generated at the end of data transfer<br>1: Interrupt generated at the end of data transfer  |
| 7         | CMDSENDEN     | Command sent interrupt enable.<br>Setting/clearing this bit by software to enable/disable the command sent interrupt.<br>0: The command has been sent without generating an interrupt<br>1: The command has been sent to generate an interrupt                                 |
| 6         | CMDRESPRECVEN | Command response received interrupt enable.<br>Setting/clearing this bit by software to enable/disable the receive acknowledge interrupt.<br>0: No interrupt is generated when a response is received<br>1: Receive a response and generate an interrupt                       |
| 5         | RXORERREN     | Rx FIFO overrun error interrupt enable.<br>Setting/clearing this bit by software to enable/disable the receive FIFO overflow error interrupt.<br>0: Receive FIFO overflow error does not generate an interrupt<br>1: Receive FIFO overflow error generates interrupt           |
| 4         | TXURERREN     | Tx FIFO underrun error interrupt enable.<br>Setting/clearing this bit by software to enable/disable the transmit FIFO underflow error interrupt.<br>0: Transmit FIFO underflow error does not generate an interrupt<br>1: Transmit FIFO underflow error generates an interrupt |
| 3         | DATTIMEOUTEN  | Data timeout interrupt enable.<br>Setting/clearing this bit by software to enable/disable the data timeout interrupt.<br>0: Data timeout does not generate an interrupt<br>1: Data timeout generates an interrupt  |
| 2         | CMDTIMEOUTEN  | Command timeout interrupt enable.<br>Setting/clearing this bit by software to enable/disable the command timeout interrupt.<br>0: Command timeout does not generate an interrupt<br>1: Command timeout generates an interrupt  |
| 1         | DCRCERREN     | Data CRC fail interrupt enable.  |

| Bit Field | Name      | Description  |
|-----------|-----------|--|
|           |           | Setting/clearing this bit by software to enable/disable the interrupt for block CRC detection failure.<br>0: Data block CRC detection failure does not generate an interrupt<br>1: Data block CRC detection failure generates an interrupt                               |
| 0         | CCRCERREN | Command CRC fail interrupt enable.<br>Setting/clearing this bit by software to enable/disable the command CRC detection failure interrupt.<br>0: Command CRC detection failure does not generate an interrupt<br>1: Command CRC detection failure generates an interrupt |

### 18.7.15 SDIO FIFO counter register (SDIO\_FIFOCOUNT)

Address offset: 0x48

Reset value: 0x0000 0000

The SDIO\_FIFOCOUNT register contains the number of data words that have not been written to or read from the FIFO. When the data transfer enable bit SDIO\_DATCTRL.DATEN is set and the DPSM is idle, the FIFO counter is loaded with the value from the data length register (see SDIO\_DATLEN). If the data length is not word-aligned (a multiple of 4), the last remaining 1~3 bytes are treated as a word.

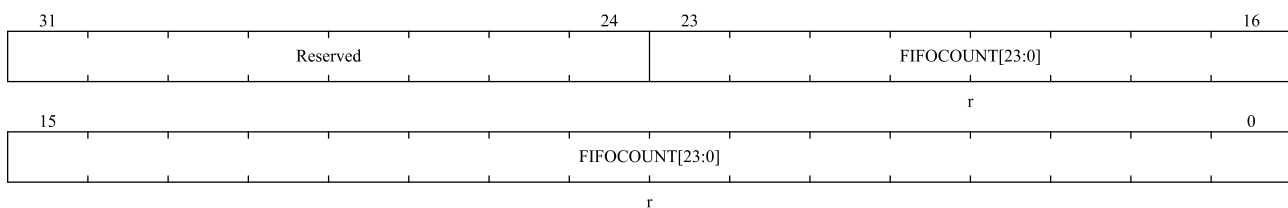

| Bit Field | Name      | Description  |
|-----------|-----------|--|
| 31:24     | Reserved  | Reserved, the reset value must be maintained.                    |
| 23:0      | FIFOCOUNT | The number of data words to be written to or read from the FIFO. |

### 18.7.16 SDIO data FIFO register (SDIO\_DATAFIFO)

Address offset: 0x80

Reset value: 0x0000 0000

The receive and transmit FIFO is a 32-bit wide read or write set of registers, it contains 32 registers on consecutive 32 addresses, the CPU can use the FIFO to read and write multiple operands.

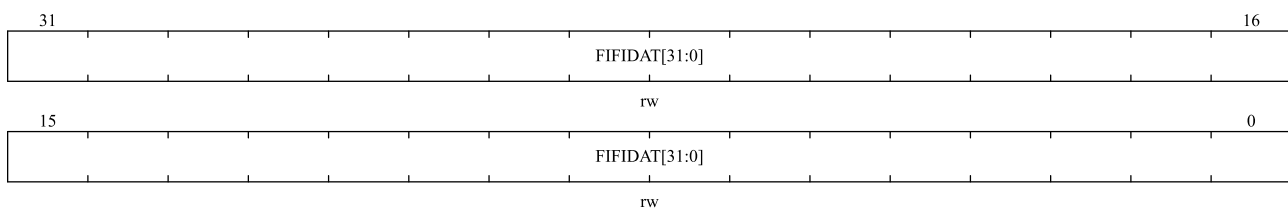

| Bit Field | Name    | Description                     |
|-----------|---------|---------------------------------|
| 31:0      | FIFIDAT | Receive and transmit FIFO data. |

|  |  |   |
|--|--|---|
|  |  | The FIFO data occupies 32 entries of 32-bit words at the address:<br>(SDIO base address + 0x80) to (SDIO base address + 0xFC) |
|--|--|---|

## 19 Universal serial bus full-speed device interface (USB\_FS\_Device)

### 19.1 Introduction

Universal serial bus full-speed device interface (USB\_FS\_Device) module is a peripheral that conforms to the USB2.0 full-speed protocol. It contains the USB PHY of the physical layer and does not require an additional PHY chip. USB\_FS\_Device supports four transfer types defined in USB2.0 protocol: control transfer, bulk transfer, interrupt transfer and isochronous transfer.

### 19.2 Main features

- Comply with USB2.0 full-speed device specification
- Supports up to 8 configurable USB endpoints
- Each endpoint supports four transfer types in the USB2.0 protocol:
  - Control transfer
  - Bulk transfer
  - Interrupt transfer
  - Isochronous transfer
- Bulk endpoint/isochronous endpoint supports double buffering mechanism
- Cyclic redundancy check (CRC) generation/checking, non-return-to-zero inverted (NRZI) encoding/decoding and bit-stuffing
- Support USB suspend/resume operation
- Frame lock clock pulse generation

Figure 19-1 is a functional block diagram of a USB peripheral.

Figure 19-1 USB device block diagram

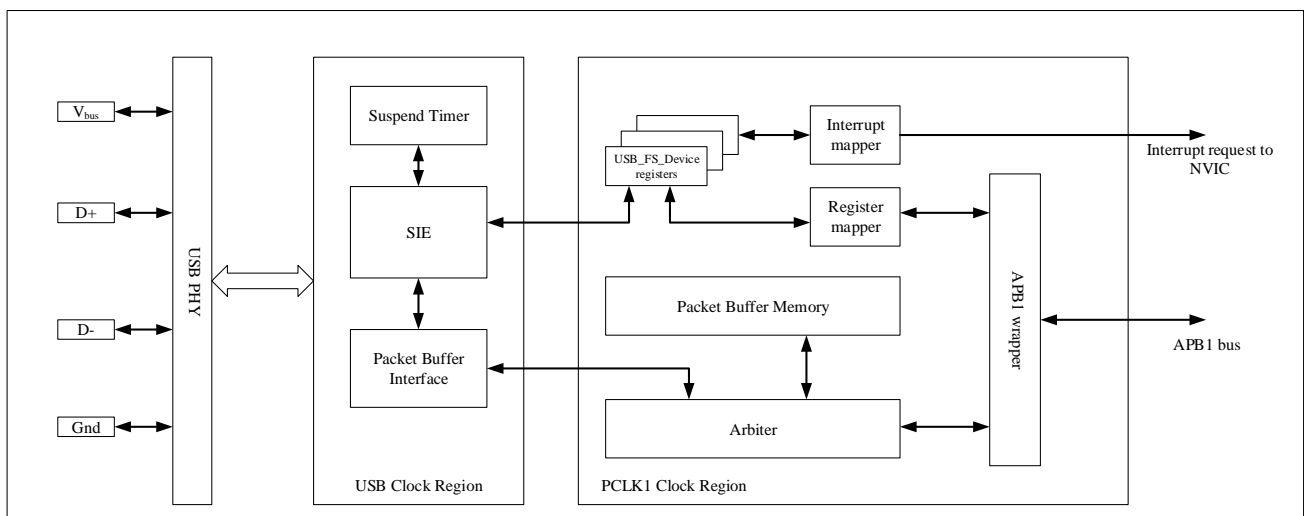

## 19.3 Clock configuration

The USB 2.0 protocol specification stipulates that the USB full-speed module uses a fixed 48MHz clock. In order to provide an accurate 48MHz clock to USB\_FS\_Device, a two-stage clock configuration is required, as follows:

- In the first stage, the 48MHz working clock is obtained by accurate frequency division of PLLCLK, so when using USB\_FS\_Device, it is necessary to ensure that the PLLCLK clock is 48MHz/72MHz/96MHz/144MHz, otherwise USB\_FS\_Device cannot work normally;
- In the second stage, enable the USB peripheral clock mounted on the APB1 bus, that is, the APB1 bus clock. Its frequency does not have to be equal to 48MHz, but can be greater or less than 48MHz.

*Note:*

- 1、 *The frequency of the APB1 bus clock must be greater than 8MHz, otherwise the data buffer may overflow/underflow.*
- 2、 *The USB registers and SRAM of the USB module can only be operated when the USB module clock is enabled.*

## 19.4 Functional description

Based on this module, data exchange can be realized between the microcontroller and the PC host through a USB connection. The data transfer between the microcontroller and the PC host is based on a 512-byte dedicated SRAM, which is the Packet Buffer Memory in Figure 19-1. USB peripherals can directly access this SRAM. The actual usage size of this dedicated SRAM is determined by the number of endpoints used and the endpoint packet buffer size of each endpoint. Each endpoint has a buffer description table entry, which describes the buffer address, size and the number of bytes that need to be transferred. For details, please refer to 19.4.2 Buffer Description Table. The SRAM is mapped to the APB1 peripheral memory area, its address is from 0x4000 6000 to 0x4000 63FF, the total capacity is 1KB, but only 512 bytes are used due to the bus width, and the buffer description table of each endpoint is also stored in this SRAM, so the maximum endpoint packet buffer that can be used by each endpoint is less than 512 bytes.

*Note:*

- 1、 *USB and CAN1 share this SRAM, so USB and CAN1 cannot be used at the same time.*

### 19.4.1 Access Packet Buffer Memory

As shown in Figure 19-1, the microcontroller communicates with the USB module through the APB1 bus, and the microcontroller accesses the Packet Buffer Memory through the APB1 wrapper. When the microcontroller and the USB module both access the Packet Buffer Memory, the Arbiter decides who can access, the arbitration logic is that half of the APB1 bus cycle is used for the microcontroller to access the Packet Buffer Memory, and the other half of the cycle is used for the USB module to access the Packet Buffer Memory, in this way, the access conflicts caused by the continuous access of the microcontroller to the Packet Buffer Memory can be avoided.

*Note:*

- 1、 *APB1 bus and USB module access Packet Buffer Memory in different ways.*

### 19.4.1.1 USB module access Packet Buffer Memory

The USB module accesses the Packet Buffer Memory in 16-bit mode, refer to Figure 19-2. When the USB module accesses the Packet Buffer Memory, first find the location of the buffer description table in the Packet Buffer Memory through the USB\_BUFTAB register. The value of the USB\_BUFTAB register indicates the starting address of the buffer description table, which must be within the memory range of the Packet Buffer Memory and be 8-byte aligned. If only endpoint 0 and endpoint 1 are used, the buffer description table only needs 16 bytes. If only endpoint 0 and endpoint 7 are used, the buffer description table needs 64 bytes. Although endpoint 1 to endpoint 6 are not used, but The description table of endpoint 7 starts from 56 bytes, so it will occupy 64 bytes of space.

### 19.4.1.2 User application access Packet Buffer Memory

The user application program on the microcontroller needs to access the Packet Buffer Memory from the APB1 bus according to 32-bit alignment and 16-bit read and write access, that is, the address of the operation data must be 32-bit aligned, and only 16-bit data can be read or written at a time, can't be 8-bit nor 32-bit. Figure 19-2 shows the way in which the user application program on the microcontroller and the USB module accesses the Packet Buffer Memory.

Figure 19-2 The user applications on the microcontrollers and the USB modules access Packet Buffer Memory

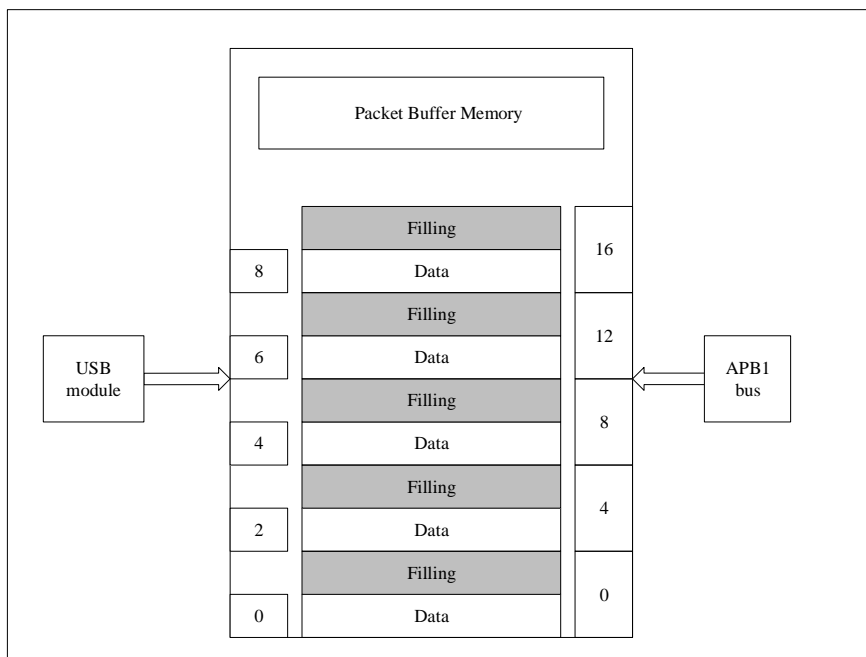

## 19.4.2 Buffer description table

The buffer description table defines the buffer address, size and the number of bytes to be transmitted for the endpoint used in the communication process. Each endpoint corresponds to two endpoint data packet buffers, one for sending and one for receiving. These endpoint packet buffers can be stored anywhere in the entire Packet Buffer Memory, and the buffer description table is also located in the Packet Buffer Memory, whose starting address is determined by the USB\_BUFTAB register.

The buffer description table has a total of 8 entries, each entry corresponds to an endpoint register, each register has two directions of sending and receiving, and each direction requires two 16-bit word buffer description tables, so each table items consist of four 16-bit words, so the start address of the buffer description table must be 8-byte aligned.

Endpoint packet buffers for unused endpoints or in the unused direction of a used endpoint may be used for other purposes. The relationship between the buffer description table and the endpoint packet buffer is shown in Figure 19-3 below.

Whether the endpoint is used for receiving or sending, the buffer description table starts with the first entry, which is the very bottom of the buffer description table. The USB module cannot access/modify the data of other endpoint packet buffers other than the currently allocated endpoint packet buffer area, For example: when the endpoint 0 packet receive buffer receives a data larger than the current endpoint 0 packet receive buffer from the PC host, the endpoint 0 only receives data up to the endpoint 0 packet receive buffer size, other redundant data is discarded and a buffer overflow exception occurs.

Figure 19-3 The relationship between the buffer description table and the endpoint packet buffer

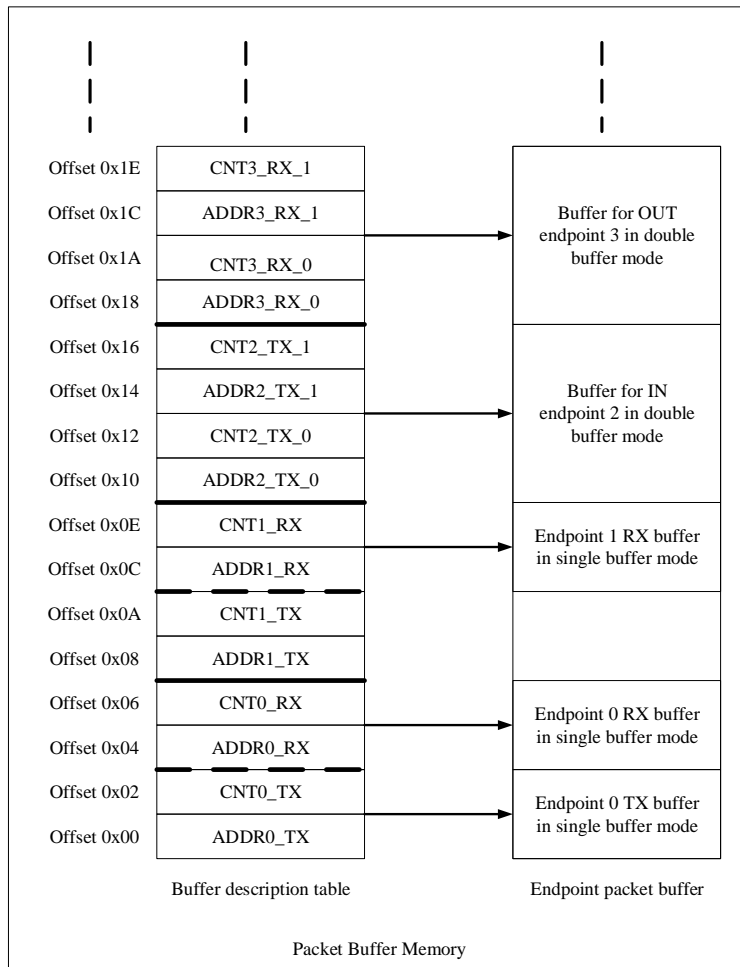

## 19.4.3 Double-buffered endpoints

### 19.4.3.1 Double buffer endpoint function introduction

When a large amount of data needs to be transmitted between the PC host and the USB device, the use of bulk transmission allows the PC host to transmit data with maximum efficiency within one frame. However, when the transmission speed is too fast, the USB device will receive a new data packet when the USB device is processing the previous data transmission. In order to correctly complete the previous data transmission, the USB can only reply the NAK handshake signal to the PC host. Due to the retransmission mechanism of bulk transfer, the PC host will

continue to retransmit the same data packet until the USB device can process the data packet and reply to the PC host with an ACK handshake signal, the PC host will stop retransmitting the data packet. Such retransmission will occupy a lot of bandwidth, thereby reducing the rate of bulk transfer. In order to solve this problem, a double buffering mechanism is introduced to improve the efficiency of bulk transfer, and flow control is implemented.

When the unidirectional endpoint uses the double buffer mechanism, both the receive buffer and the transmit buffer on the endpoint will be used, one of the buffers is used by the USB module, and the other buffer is used by the microcontroller, use the data toggle bit in the endpoint register to select which buffer is currently used, and introduce two flags for this: DATTOG and SW\_BUF. DATTOG indicates the buffer currently being used by the USB module, and SW\_BUF indicates the buffer currently being used by the application on the microcontroller. The definitions of DATTOG and SW\_BUF are shown in Table 19-1 shown. A unidirectional endpoint using the double buffer mechanism only needs to use one USB\_EPn register.

Table 19-1 DATTOG and SW\_BUF definitions

| Buffer flag | Sending endpoint                             | Receiving endpoint                            |
|-------------|--|---|
| DATTOG      | DATTOG_TX<br>(Bit 6 of the USB_EPn register) | DATTOG_RX<br>(Bit 14 of the USB_EPn register) |
| SW_BUF      | Bit 14 of the USB_EPn register               | Bit 6 of the USB_EPn register                 |

As shown in Figure 19-3, when an endpoint uses the double buffer mechanism, all four buffer description table entries of the endpoint will be used. DATTOG and SW\_BUF are responsible for flow control. When a transfer is complete, the USB hardware toggles the DATTOG bit; when the application on the microcontroller has finished processing the data, the software toggles SW\_BUF bit. After the first transfer starts, in the subsequent transfer process, if the values of DATTOG and SW\_BUF are equal, a buffer access conflict occurs between the USB module and the application, the transfer is paused, and a NAK handshake packet is sent to the host; when the values of DATTOG and SW\_BUF are not equal, normal USB communication can be performed.

Table 19-2 How to use double buffering

| Endpoint type | DATTOG | SW_BUF | Buffer used by the USB module | Buffers used by the application |
|---------------|--------|--------|-------------------------------|---------------------------------|
| IN Endpoint   | 0      | 1      | ADDRn_TX_0/CNTn_TX_0          | ADDRn_TX_1/CNTn_TX_1            |
|               | 1      | 0      | ADDRn_TX_1/CNTn_TX_1          | ADDRn_TX_0/CNTn_TX_0            |
|               | 0      | 0      | Endpoint is in NAK state      | ADDRn_TX_0/CNTn_TX_0            |
|               | 1      | 1      | Endpoint is in NAK state      | ADDRn_TX_1/CNTn_TX_1            |
| OUT Endpoint  | 0      | 1      | ADDRn_RX_0/CNTn_RX_0          | ADDRn_RX_1/CNTn_RX_1            |
|               | 1      | 0      | ADDRn_RX_1/CNTn_RX_1          | ADDRn_RX_0/CNTn_RX_0            |
|               | 0      | 0      | Endpoint is in NAK state      | ADDRn_RX_0/CNTn_RX_0            |
|               | 1      | 1      | Endpoint is in NAK state      | ADDRn_RX_1/CNTn_RX_1            |

*Note:*

1. The double-buffered bulk endpoint will only set the endpoint to the NAK state when there is a buffer access conflict, and will not set the endpoint to the NAK state after each correct transmission is completed.

### 19.4.3.2 Double-buffered endpoint usage

If you want to use double-buffered bulk endpoints, you can set them up as follows:

- Set USB\_EPn.EP\_TYPE = 00, define the endpoint as a bulk endpoint

- Set `USB_EPn.EP_KIND = 1`, define endpoint as double buffer endpoint

As shown in Figure 19-3, when double-buffered bulk endpoint 3 performs data transmission in the OUT direction, assuming `DATTOG = 1` and `SW_BUF = 0`, it means that the application can process the data in buffer0 corresponding to `ADDR3_RX_0/CNT3_RX_0`, after receiving the data from the USB bus, the USB module fills the data into the buffer1 corresponding to `ADDR3_RX_1/CNT3_RX_1`. When a transaction transfer on the USB bus is completed, the hardware will toggle `DATTOG = 0`. If the application has not finished processing the data in buffer0 corresponding to `ADDR3_RX_0/CNT3_RX_0`, the software will not toggle `SW_BUF` (`SW_BUF = 0`). If there is another OUT data packet transmission on the USB bus at this time, the USB device will automatically reply the NAK handshake signal to indicate flow control until the application finishes processing the data in buffer0 corresponding to `ADDR3_RX_0/CNT3_RX_0`, and the software toggle `SW_BUF = 1`. In this case, the `DATTOG` and `SW_BUF` values are different. If there is another OUT data packet transmission on the USB bus, the USB device can receive data normally, and fill the received data into buffer0 corresponding to `ADDR3_RX_0/CNT3_RX_0`, and the application can process the buffer1 corresponding to `ADDR3_RX_1/CNT3_RX_1`. As shown in Figure 19-4 below.

Figure 19-4 Double buffered bulk endpoint example

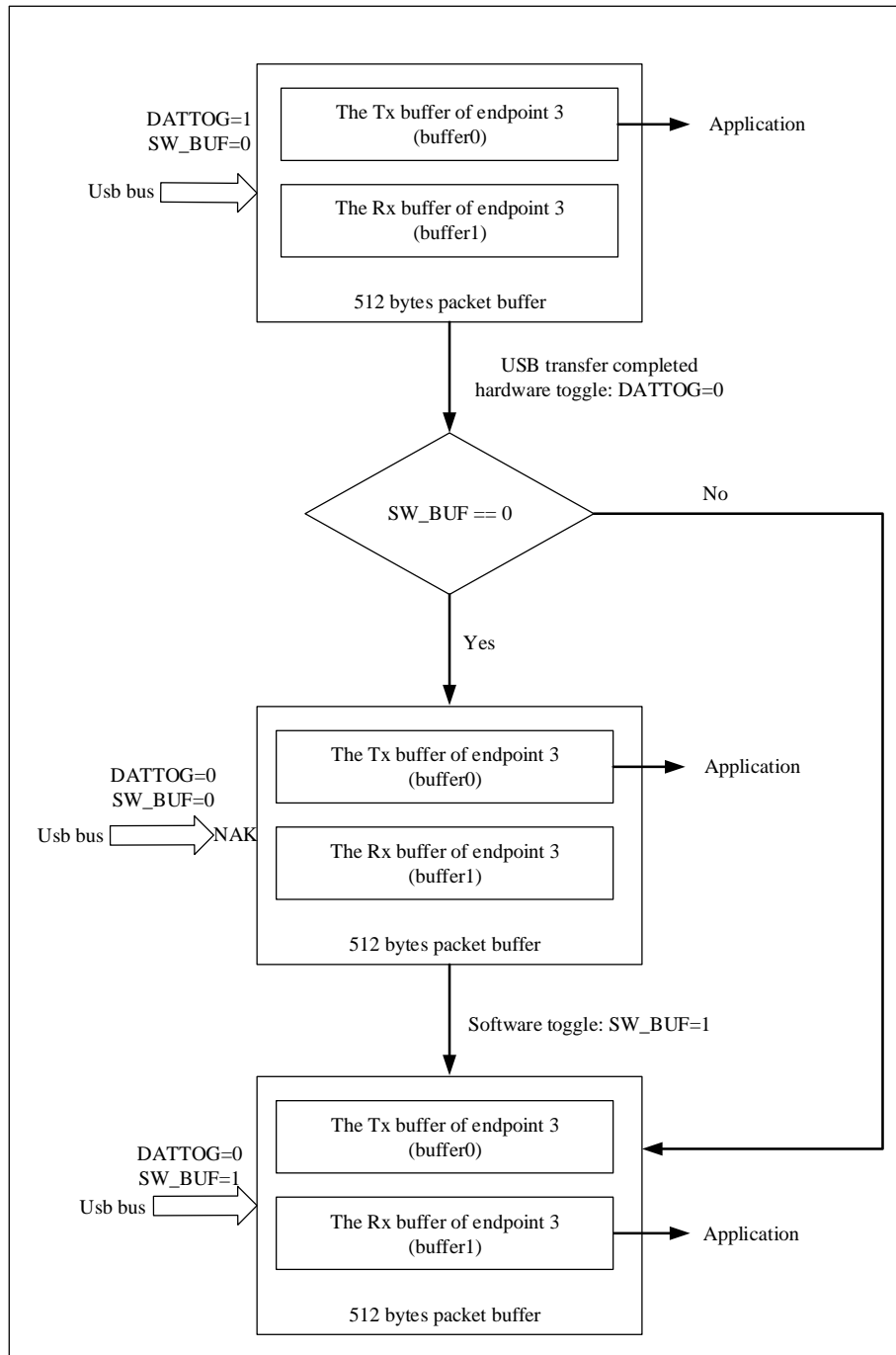

## 19.4.4 USB transfer

### 19.4.4.1 Overview of USB transfer

A USB transfer consists of multiple transactions, and a transaction consists of multiple packets.

A packet is the basic unit of USB transmission. All data must be packaged before being transmitted on the USB bus. The process of one time receiving or sending data on the USB is called a transaction, and there are three types of transactions: Setup transaction, Data IN transaction, and Data OUT transaction.

#### 19.4.4.2 IN transaction

When the host wants to read the data of the USB device, the host sends a PID IN token packet to the USB device. After the USB device receives the IN token packet correctly, if the address matches a configured endpoint address, the USB module will access the corresponding USB\_ADDRn\_TX and USB\_CNTn\_TX registers according to the buffer description table entry of the endpoint, and store the values in these two registers to the internal 16-bit ADDR register and CNT register that cannot be accessed by the application. The ADDR register is used as a pointer to the endpoint's corresponding endpoint packet send buffer, and the CNT register is used to record the number of remaining untransferred bytes. The USB bus uses the low byte first method to read data from the endpoint data packet sending buffer. The data starts to read data from the endpoint data packet sending buffer pointed to by USB\_ADDRn\_TX, and the length is USB\_CNTn\_TX/2 words. If the data packet sent is an odd number of bytes, only the lower 8 bits of the last word are used.

After the USB device receives the PID IN token packet sent by the host, the USB processing flow for the IN transaction is as follows:

- If the device address information and endpoint information in this IN token packet are valid, and the status of the endpoint specified in the token packet is VALID, the USB device sends a PID DATA0 or DATA1 packet according to the USB\_EPn.DATTOG\_TX bit, send the prepared data to the host, when the last data byte is sent, the calculated data CRC will also be sent to the host. After the USB device receives the PID ACK handshake packet returned by the host. The hardware toggles the USB\_EPn.DATTOG\_TX bit, the hardware sets the endpoint's sending state to NAK state (USB\_EPn.STS\_TX = 10), and the hardware sets USB\_EPn.CTRS\_TX bit to generate a correct sending interrupt. The software responds to the CTRS\_TX interrupt, identifies which endpoint the communication is on by checking the USB\_STS.EP\_ID bit, identifies the communication direction through USB\_STS.DIR, clears the interrupt flag, and prepares the next data to be sent, and then the software sets the endpoint sending status to VALID status (USB\_EPn.STS\_TX = 11).
- If the endpoint specified in this IN token packet is invalid, the USB device does not send data packets, but sends PID NAK or STALL handshake packets according to USB\_EPn.STS\_TX.

#### 19.4.4.3 OUT and SETUP transaction

When the host wants to send data or commands to the USB device, the host will send the PID OUT or SETUP token packet to the USB device. After the USB device receives the OUT or SETUP token correctly, if the address matches a configured endpoint address, the USB module will access the corresponding USB\_ADDRn\_RX and USB\_CNTn\_RX registers according to the buffer description table entry of the endpoint. Store the value of the USB\_ADDRn\_RX register into the internal ADDR register, and reset the internal CNT register at the same time. The ADDR register is used as a pointer to the endpoint data packet receiving buffer corresponding to the endpoint, and the CNT register is used to record the number of received data bytes, and initialize the internal 16-bit BUF\_COUNT register that cannot be accessed by the application program with the BL\_SIZE and NUM\_BLK values in the USB\_CNTn\_RX register, which is used for buffer overflow detection. When the USB module receives data from the USB bus, the USB module organizes the received data in words (the first received is the low byte), and store it in the endpoint data packet receiving buffer pointed to by ADDR, at the same time, the CNT value is automatically incremented, and the BUF\_COUNT value is automatically decremented.

After the USB device receives the PID OUT or SETUP token packet sent by the host, the USB processing flow for OUT or SETUP is as follows:

- If the device address information and endpoint information in the OUT or SETUP token packet are valid, and

the status of the endpoint specified in the token packet is VALID, USB device moves data from the hardware buffer that cannot be accessed by the application to the endpoint data packet receiving buffer that can be accessed by the application. Then the USB device checks the received CRC. If the CRC is correct, the USB device replies to the host with a PID ACK handshake packet; If there is an error in the CRC or other error types (bit stuffing, frame error, etc.), the USB device will not reply to the host with an ACK handshake packet, and USB\_STS.ERROR is set, at this time, the application does not need to do any processing, the USB device will automatically recover to be ready to receive the next transfer. If the received data size exceeds the data packet buffer size of the receiving endpoint, the USB device will stop receiving data, and the hardware will reply to the STALL handshake packet and set the buffer overflow error, but no interrupt will be generated. After the USB device replies the PID ACK handshake packet to the host, the USB device toggles the USB\_EPn.DATTOG\_RX bit by the hardware, the hardware sets the endpoint receiving state to NAK state (USB\_EPn.STS\_RX = 10), and the hardware sets USB\_EPn.CTRS\_RX to generate a correct receive interrupt. The software responds to the CTRS\_RX interrupt, identifies the communication on which endpoint by checking the USB\_STS.EP\_ID bit, identifies the communication direction through USB\_STS.DIR, clears the interrupt flag, processes the data received from the host, and after processing the received data, the software then sets the receiving state of the endpoint to the VALID state (USB\_EPn.STS\_RX = 11) to enable the next transmission.

- If the endpoint specified in this OUT or SETUP token packet is invalid, the USB device sends a PID NAK or STALL handshake packet according to USB\_EPn.STS\_RX.

*Note:*

1. *When the USB device receives data from the host, if the size of the received data exceeds the size of the data packet buffer of the receiving endpoint, the hardware will automatically stop writing, that is, the data in the data packet buffer of other endpoints will never be overwritten.*

#### 19.4.4.4 Control transfer

Control transfer consists of 3 stages, 1 Setup stage + 0/multiple Data stages in the same direction + 1 Status stage. SETUP transaction can only be completed by the control endpoint, and the process of SETUP transaction and OUT transaction is similar. When a Setup transaction is completed correctly, the hardware generates a USB\_EPn.CTRS\_RX interrupt. In the interrupt, the software first changes the Tx and Rx direction states of the USB device endpoint to NAK, and then checks the USB\_EPn.SETUP bit to determine whether it is a SETUP transaction or an OUT transaction. And according to the corresponding fields in the SETUP token packet, it is judged whether there is a data stage in the future, and if there is a data stage, whether the data stage is IN transmission or OUT transmission. As shown in Figure 19-5, take control write transfer as an example. Before enabling subsequent data stages, determine whether the Data stage is the last Data stage:

- If it is not the last Data stage, that is, it is not the last data packet, before enabling the reception of OUT transactions, set the unused direction Tx status to STALL to prevent the host from prematurely ending the Data stage and entering the Status stage, the USB device can return a PID STALL handshake packet, and the Rx state of the direction to be used is set to VALID. When the first OUT transaction is completed correctly, the hardware generates the USB\_EPn.CTRS\_RX interrupt, and changes the Rx direction state of the USB device endpoint to NAK, the Tx direction state remains unchanged, the software judges whether the next OUT transaction to be enabled is the last Data stage in the interrupt. If it is not the last Data stage, before enabling the receiving OUT transaction, the software then sets the Rx direction status of the USB device endpoint to VALID, and the Tx direction status remains unchanged;
- If it is the last Data stage, before enabling the reception of the last OUT transaction, the software sets the Tx

direction status that was not used in the previous Data stage to NAK, so that even if the host starts the Status stage immediately after the last Data stage, the USB device can still remain in the state of waiting for the end of the control transfer, and the Rx direction state is set to VALID, ready to receive the last packet of data;

After the last OUT transaction is completed correctly, the hardware generates the USB\_EPn.CTRS\_RX interrupt, and sets the Rx direction state of the USB device endpoint to NAK, and the TX direction state remains unchanged. When the software prepares the 0-length data packet that needs to be sent in the Status stage in the interrupt, the software changes the Tx direction status of the USB device endpoint to VALID.

Control read transfers are similar to control write transfers with the following differences:

- To control read transfer, after the last IN transaction in the Data stage is completed correctly, before enabling the Status stage in the OUT direction, in addition to setting the Rx direction status of the USB device endpoint to VALID, you also need to set STATUS\_OUT (USB\_EPn.EP\_KIND) to 1, indicates that the next stage will be the Status stage in the OUT direction, and the subsequent OUT transaction must be a 0-length data packet, otherwise an error will be generated.
- After the Status stage is over, the software clears the STATUS\_OUT (USB\_EPn.EP\_KIND) bit, the Rx direction status of the USB device endpoint is set to VALID, ready to receive a new command request, and the Tx direction status is set to NAK, indicating that before the next SETUP packet transmission is completed, the request for data transfer is not accepted.

*Note:*

- 1、 *Bidirectional endpoint 0 is used as the default control endpoint to handle control transfers.*
- 2、 *As defined in the USB2.0 specification, after the USB device receives the PID SETUP token packet, it cannot reply with the PID NAK or STALL handshake packet, but only with the PID ACK handshake packet. If the transmission of the SETUP packet fails, the next SETUP packet will be raised. If the Rx state of endpoint 0 is set to STALL or NAK, the USB module can still receive the SETUP token packet.*
- 3、 *When USB\_EP0.CTRS\_RX = 1, the USB module receives the SETUP token packet again, the USB module will discard the SETUP token packet, and will not reply any handshake packet to the host, forcing the host to send the SETUP token packet again.*

Figure 19-5 Control transfer

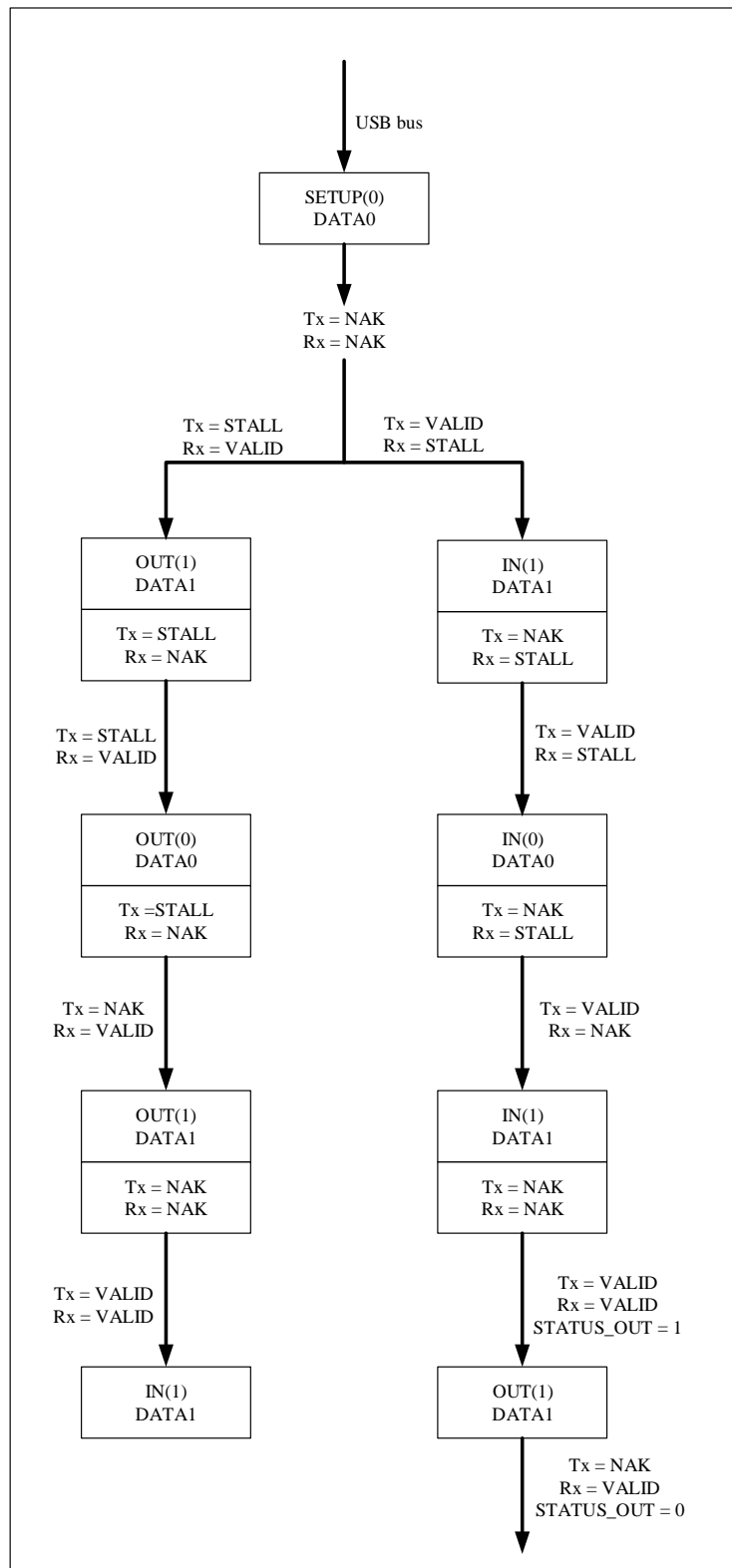

#### 19.4.4.5 Isochronous transfer

Transmissions that require a fixed and precise data rate are defined as isochronous transfer. If an endpoint is defined as an isochronous endpoint during enumeration, the USB host will allocate the required bandwidth for the endpoint in each frame of transmission, but in order to save bandwidth, isochronous transfer does not have a retransmission

mechanism, that is, there is no handshake stage, there is no handshake packet after the data packet, so there is no need to use the data toggle mechanism, and the isochronous transfer only transmits the PID DATA0 data packet.

The isochronous endpoint uses a double buffer mechanism to reduce the processing pressure of the application. The buffer used by the USB module is identified by the DATTOG bit. In the same register, the USB\_EPn.DATTOG\_RX bit identifies the receiving isochronous endpoint, and the USB\_EPn.DATTOG\_TX bit identifies the sending isochronous endpoint. Compared with the bulk double buffering mechanism, the isochronous double buffering mechanism has no SW\_BUF, because the buffer that the application can access is the one not indicated by DATTOG, so to achieve bidirectional isochronous transmission, two USB\_EPn registers need to be used. The use of double-buffered isochronous endpoints is shown in Table 19-3.

Table 19-3 How to use isochronous double buffering

| Endpoint type | DATTOG | Buffer used by the USB module | Buffers used by the application |
|---------------|--------|-------------------------------|---------------------------------|
| IN Endpoint   | 0      | ADDRn_TX_0/CNTn_TX_0          | ADDRn_TX_1/CNTn_TX_1            |
|               | 1      | ADDRn_TX_1/CNTn_TX_1          | ADDRn_TX_0/CNTn_TX_0            |
| OUT Endpoint  | 0      | ADDRn_RX_0/CNTn_RX_0          | ADDRn_RX_1/CNTn_RX_1            |
|               | 1      | ADDRn_RX_1/CNTn_RX_1          | ADDRn_RX_0/CNTn_RX_0            |

The application initializes the DATTOG bits based on the buffer to be used the first time. Each time the transfer is completed, USB\_EPn.CTRS\_RX or USB\_EPn.CTRS\_TX is set according to the direction in which the transmission is enabled, and a corresponding interrupt is generated. If a CRC error or buffer overflow error occurs, the USB\_EPn.CTRS\_RX or USB\_EPn.CTRS\_TX interrupt event can still be triggered, but if it is a CRC error, the hardware will set the USB\_STS.ERROR bit, indicating that the data may be corrupted. At the same time, the hardware toggles the DATTOG bit, but the USB\_EPn.STS\_RX or USB\_EPn.STS\_TX bits are not affected.

Isochronous endpoint definition: set USB\_EPn.EP\_TYPE = 10. Since the isochronous endpoint has no handshake mechanism, the status of the isochronous endpoint can only be set to VALID or DISABLED, and it is illegal to set it to STALL or NAK.

*Note:*

1. Compared with bulk double buffering, since isochronous double buffering has no handshake mechanism, isochronous double buffering has no flow control mechanism.

## 19.4.5 USB events and interrupts

Every USB behavior is initiated by the application and driven by USB interrupts or events. After a system reset, the application needs to wait for a series of USB interrupts and events.

### 19.4.5.1 Reset events

#### 19.4.5.1.1 System reset and power-on reset

After a system reset or power-on reset occurs, the software first needs to enable the clock signal of the USB module, then clear the reset signal to access the registers of the USB module, and finally open the analog part connected to the USB transceiver. The software operation process is as follows:

- Enable the clock signal of the USB module
- Clear the USB\_CTRL.PD bit

- Wait for the internal reference voltage to stabilize, because it takes a start-up time to turn on the internal voltage, during which the USB transceiver is in an indeterminate state
- Clear the USB\_CTRL.FRST bit
- Clear the USB\_STS register, remove pending interrupts, and enable other units

*Note:*

1、 Every time the USB module is enabled after system reset or power-on reset, the pull-up resistor on the DP signal line needs to be configured. This control bit is located in bit28 of the base address 0x4000 1820 register. Set bit28 to 1 to enable the pull-up resistor on the DP signal line, otherwise disable the pull-up resistor. Modification of other bits of this register is not allowed.

#### 19.4.5.1.2 USB reset (reset interrupt)

When a USB reset occurs, the state of the USB module is the same as after a system reset: all endpoints are disabled for communication. The software needs to do the following:

- After the reset interrupt is generated, the software must enable the transmission of endpoint 0 within 10ms
- Set the USB\_ADDR.EFUC bit
- Initialize the USB\_EP0 register and its associated endpoint packet buffer

#### 19.4.5.2 Suspend and resume events

##### 19.4.5.2.1 Suspend events

When full-speed USB is communicating normally, the host will send a PID SOF token packet every millisecond. If the USB module detects that 3 consecutive SOF packets are lost, that is, the USB bus is in an idle state within 3ms, the hardware sets the USB\_STS.SUSPD bit, triggers a suspend interrupt, and the USB device enters the suspend state. The USB2.0 standard stipulates that in the suspend state, the average current consumption on the USB bus does not exceed 2.5mA, but self-powered devices do not need to strictly abide by this regulation.

*Note:*

1、 After the USB device enters the suspend state, it must still have the function of detecting the RESET signal.

##### 19.4.5.2.2 Resume events

After the USB device enters the suspend state, to resume normal USB communication, the USB host can initiate a resume sequence or a reset sequence, or the USB device itself can trigger the resume sequence, but the resume sequence can only be ended by the USB host. If the reset sequence initiated by the USB host resumes the USB device, according to the regulations in the USB2.0 standard, it must be ensured that the resume process does not exceed 10ms.

Table 19-4 lists the USB\_FN.RXDP\_STS bit and the USB\_FN.RXDM\_STS bit to identify what triggers the resume event and the corresponding software action.

Table 19-4 Resume event detection

| [USB_FN.RXDP_STS, USB_FN.RXDM_STS] | Wake-up event              | Software operation      |
|------------------------------------|----------------------------|-------------------------|
| 00                                 | Root reset                 | None                    |
| 01                                 | Root resume                | None                    |
| 10                                 | None (noise on bus)        | Go back in Suspend mode |
| 11                                 | Not allowed (noise on bus) | Go back in Suspend mode |

Note:

1. The `USB_CTRL.RESUM` bit can only be set when `USB_CTRL.FSUSPD = 1`, i.e. the USB module is in suspend state.

### 19.4.5.3 USB interrupt

The USB controller has 3 interrupt lines, which are as follows:

- USB low priority interrupt (channel 20): can be triggered by all USB events;
- USB high-priority interrupt (channel 19): can only be triggered by correct transfer events for isochronous and double-buffered bulk transfers;
- USB resume interrupt (channel 42): triggered by a resume event from USB suspend mode.

### 19.4.6 Endpoint initialization

1. Initialize the `USB_ADDRn_TX` or `USB_ADDRn_RX` register, configure the endpoint Tx or Rx packet buffer start address;
2. According to the actual usage scenario of the endpoint, configure the `USB_EPn.EP_TYPE` bit and the `USB_EPn.EP_KIND` bit to set the endpoint type and buffer type;
3. Perform different operations based on the endpoint direction:
  - If it is a sending endpoint
    - 1) Set the `USB_EPn.STS_TX` bit to enable the sending function of the endpoint
    - 2) Configure the `USB_CNTn_TX.CNTn_TX` bit, set the endpoint data packet send buffer size
  - If it is a receiving endpoint
    - 1) Set the `USB_EPn.STS_RX` bit to enable the receiving function of the endpoint
    - 2) Configure the `USB_CNTn_RX.BL_SIZE` bit and the `USB_CNTn_RX.NUM_BLK` bit to set the endpoint packet receive buffer size

## 19.5 USB registers

The peripheral registers can be accessed by half-words (16-bit) or words (32-bit).

USB base address: 0x4000 5C00

### 19.5.1 USB register overview

Table 19-5 USB register overview

| Offset | Register    | 31       | 30 | 29 | 28 | 27 | 26 | 25 | 24 | 23 | 22 | 21 | 20 | 19 | 18 | 17 | 16 | 15      | 14        | 13          | 12    | 11           | 10      | 9       | 8         | 7           | 6           | 5 | 4 | 3 | 2 | 1 | 0 |   |   |   |   |   |   |   |   |   |
|--------|-------------|----------|----|----|----|----|----|----|----|----|----|----|----|----|----|----|----|---------|-----------|-------------|-------|--------------|---------|---------|-----------|-------------|-------------|---|---|---|---|---|---|---|---|---|---|---|---|---|---|---|
| 000h   | USB_EP0     | Reserved |    |    |    |    |    |    |    |    |    |    |    |    |    |    |    | CTRS_RX | DATTOG_RX | STS_RX[1:0] | SETUP | EP_TYPE[1:0] | EP_KIND | CTRS_TX | DATTOG_TX | STS_TX[1:0] | EPADDR[3:0] |   |   |   |   |   |   |   |   |   |   |   |   |   |   |   |
|        | Reset Value |          |    |    |    |    |    |    |    |    |    |    |    |    |    |    |    | 0       | 0         | 0           | 0     | 0            | 0       | 0       | 0         | 0           | 0           | 0 | 0 | 0 | 0 | 0 | 0 | 0 | 0 | 0 | 0 | 0 | 0 | 0 | 0 | 0 |

| Offset | Register    | 31       | 30 | 29 | 28 | 27 | 26 | 25 | 24 | 23 | 22 | 21 | 20 | 19 | 18 | 17 | 16 | 15           | 14        | 13          | 12     | 11           | 10      | 9       | 8         | 7           | 6           | 5         | 4     | 3          | 2       | 1  | 0        |   |   |   |   |   |   |   |   |   |   |   |   |   |
|--------|-------------|----------|----|----|----|----|----|----|----|----|----|----|----|----|----|----|----|--------------|-----------|-------------|--------|--------------|---------|---------|-----------|-------------|-------------|-----------|-------|------------|---------|----|----------|---|---|---|---|---|---|---|---|---|---|---|---|---|
| 004h   | USB_EP1     | Reserved |    |    |    |    |    |    |    |    |    |    |    |    |    |    |    | CTRS_RX      | DATTOG_RX | STS_RX[1:0] | SETUP  | EP_TYPE[1:0] | EP_KIND | CTRS_TX | DATTOG_TX | STS_TX[1:0] | EPADDR[3:0] |           |       |            |         |    |          |   |   |   |   |   |   |   |   |   |   |   |   |   |
|        | Reset Value | 0        |    |    |    |    |    |    |    |    |    |    |    |    |    |    |    | 0            | 0         | 0           | 0      | 0            | 0       | 0       | 0         | 0           | 0           | 0         | 0     | 0          | 0       | 0  | 0        | 0 | 0 | 0 | 0 | 0 | 0 | 0 | 0 | 0 | 0 |   |   |   |
| 008h   | USB_EP2     | Reserved |    |    |    |    |    |    |    |    |    |    |    |    |    |    |    | CTRS_RX      | DATTOG_RX | STS_RX[1:0] | SETUP  | EP_TYPE[1:0] | EP_KIND | CTRS_TX | DATTOG_TX | STS_TX[1:0] | EPADDR[3:0] |           |       |            |         |    |          |   |   |   |   |   |   |   |   |   |   |   |   |   |
|        | Reset Value | 0        |    |    |    |    |    |    |    |    |    |    |    |    |    |    |    | 0            | 0         | 0           | 0      | 0            | 0       | 0       | 0         | 0           | 0           | 0         | 0     | 0          | 0       | 0  | 0        | 0 | 0 | 0 | 0 | 0 | 0 | 0 | 0 | 0 | 0 | 0 |   |   |
| 00Ch   | USB_EP3     | Reserved |    |    |    |    |    |    |    |    |    |    |    |    |    |    |    | CTRS_RX      | DATTOG_RX | STS_RX[1:0] | SETUP  | EP_TYPE[1:0] | EP_KIND | CTRS_TX | DATTOG_TX | STS_TX[1:0] | EPADDR[3:0] |           |       |            |         |    |          |   |   |   |   |   |   |   |   |   |   |   |   |   |
|        | Reset Value | 0        |    |    |    |    |    |    |    |    |    |    |    |    |    |    |    | 0            | 0         | 0           | 0      | 0            | 0       | 0       | 0         | 0           | 0           | 0         | 0     | 0          | 0       | 0  | 0        | 0 | 0 | 0 | 0 | 0 | 0 | 0 | 0 | 0 | 0 | 0 |   |   |
| 010h   | USB_EP4     | Reserved |    |    |    |    |    |    |    |    |    |    |    |    |    |    |    | CTRS_RX      | DATTOG_RX | STS_RX[1:0] | SETUP  | EP_TYPE[1:0] | EP_KIND | CTRS_TX | DATTOG_TX | STS_TX[1:0] | EPADDR[3:0] |           |       |            |         |    |          |   |   |   |   |   |   |   |   |   |   |   |   |   |
|        | Reset Value | 0        |    |    |    |    |    |    |    |    |    |    |    |    |    |    |    | 0            | 0         | 0           | 0      | 0            | 0       | 0       | 0         | 0           | 0           | 0         | 0     | 0          | 0       | 0  | 0        | 0 | 0 | 0 | 0 | 0 | 0 | 0 | 0 | 0 | 0 | 0 | 0 |   |
| 014h   | USB_EP5     | Reserved |    |    |    |    |    |    |    |    |    |    |    |    |    |    |    | CTRS_RX      | DATTOG_RX | STS_RX[1:0] | SETUP  | EP_TYPE[1:0] | EP_KIND | CTRS_TX | DATTOG_TX | STS_TX[1:0] | EPADDR[3:0] |           |       |            |         |    |          |   |   |   |   |   |   |   |   |   |   |   |   |   |
|        | Reset Value | 0        |    |    |    |    |    |    |    |    |    |    |    |    |    |    |    | 0            | 0         | 0           | 0      | 0            | 0       | 0       | 0         | 0           | 0           | 0         | 0     | 0          | 0       | 0  | 0        | 0 | 0 | 0 | 0 | 0 | 0 | 0 | 0 | 0 | 0 | 0 | 0 | 0 |
| 018h   | USB_EP6     | Reserved |    |    |    |    |    |    |    |    |    |    |    |    |    |    |    | CTRS_RX      | DATTOG_RX | STS_RX[1:0] | SETUP  | EP_TYPE[1:0] | EP_KIND | CTRS_TX | DATTOG_TX | STS_TX[1:0] | EPADDR[3:0] |           |       |            |         |    |          |   |   |   |   |   |   |   |   |   |   |   |   |   |
|        | Reset Value | 0        |    |    |    |    |    |    |    |    |    |    |    |    |    |    |    | 0            | 0         | 0           | 0      | 0            | 0       | 0       | 0         | 0           | 0           | 0         | 0     | 0          | 0       | 0  | 0        | 0 | 0 | 0 | 0 | 0 | 0 | 0 | 0 | 0 | 0 | 0 | 0 | 0 |
| 01Ch   | USB_EP7     | Reserved |    |    |    |    |    |    |    |    |    |    |    |    |    |    |    | CTRS_RX      | DATTOG_RX | STS_RX[1:0] | SETUP  | EP_TYPE[1:0] | EP_KIND | CTRS_TX | DATTOG_TX | STS_TX[1:0] | EPADDR[3:0] |           |       |            |         |    |          |   |   |   |   |   |   |   |   |   |   |   |   |   |
|        | Reset Value | 0        |    |    |    |    |    |    |    |    |    |    |    |    |    |    |    | 0            | 0         | 0           | 0      | 0            | 0       | 0       | 0         | 0           | 0           | 0         | 0     | 0          | 0       | 0  | 0        | 0 | 0 | 0 | 0 | 0 | 0 | 0 | 0 | 0 | 0 | 0 | 0 | 0 |
| 040h   | USB_CTRL    | Reserved |    |    |    |    |    |    |    |    |    |    |    |    |    |    |    | CTRS         | PMAOM     | ERRORM      | WKUPM  | SUSPDM       | RSTM    | SOFM    | ESOFM     | Reserved    |             |           | RESUM | FSUSPD     | LP_MODE | PD | FRST     |   |   |   |   |   |   |   |   |   |   |   |   |   |
|        | Reset Value | 0        |    |    |    |    |    |    |    |    |    |    |    |    |    |    |    | 0            | 0         | 0           | 0      | 0            | 0       | 0       | 0         | 0           | 0           | 0         | 0     | 0          | 0       | 0  | 0        | 0 | 0 | 0 | 0 | 0 | 0 | 0 | 0 | 0 | 0 | 0 | 0 | 0 |
| 044h   | USB_STS     | Reserved |    |    |    |    |    |    |    |    |    |    |    |    |    |    |    | CTRS         | PMAO      | ERROR       | WKUP   | SUSPD        | RST     | SOF     | ESOF      | Reserved    |             |           | DIR   | EP_ID[3:0] |         |    |          |   |   |   |   |   |   |   |   |   |   |   |   |   |
|        | Reset Value | 0        |    |    |    |    |    |    |    |    |    |    |    |    |    |    |    | 0            | 0         | 0           | 0      | 0            | 0       | 0       | 0         | 0           | 0           | 0         | 0     | 0          | 0       | 0  | 0        | 0 | 0 | 0 | 0 | 0 | 0 | 0 | 0 | 0 | 0 | 0 | 0 | 0 |
| 048h   | USB_FN      | Reserved |    |    |    |    |    |    |    |    |    |    |    |    |    |    |    | RXDP_STS     | RXDM_STS  | LOCK        | LSTSOF | [1:0]        |         |         | FN[10:0]  |             |             |           |       |            |         |    |          |   |   |   |   |   |   |   |   |   |   |   |   |   |
|        | Reset Value | 0        |    |    |    |    |    |    |    |    |    |    |    |    |    |    |    | 0            | 0         | 0           | 0      | 0            | X       | X       | X         | X           | X           | X         | X     | X          | X       | X  | X        | X | X | X | X | X | X | X | X | X | X | X | X |   |
| 04Ch   | USB_ADDR    | Reserved |    |    |    |    |    |    |    |    |    |    |    |    |    |    |    | Reserved     |           |             |        |              |         |         |           |             |             | ADDR[6:0] |       |            |         |    |          |   |   |   |   |   |   |   |   |   |   |   |   |   |
|        | Reset Value | 0        |    |    |    |    |    |    |    |    |    |    |    |    |    |    |    | 0            |           |             |        |              |         |         |           |             |             | 0         | 0     | 0          | 0       | 0  | 0        | 0 | 0 | 0 | 0 | 0 | 0 | 0 | 0 | 0 | 0 | 0 |   |   |
| 050h   | USB_BUFTAB  | Reserved |    |    |    |    |    |    |    |    |    |    |    |    |    |    |    | BUFTAB[15:3] |           |             |        |              |         |         |           |             |             |           |       |            |         |    | Reserved |   |   |   |   |   |   |   |   |   |   |   |   |   |
|        | Reset Value | 0        |    |    |    |    |    |    |    |    |    |    |    |    |    |    |    | 0            |           |             |        |              |         |         |           |             |             |           |       |            |         |    | 0        |   |   |   |   |   |   |   |   |   |   |   |   |   |

## 19.5.2 USB endpoint n register (USB\_EPn), n=[0..7]

Address offset: 0x00 to 0X1C

Reset value: 0x0000 0000

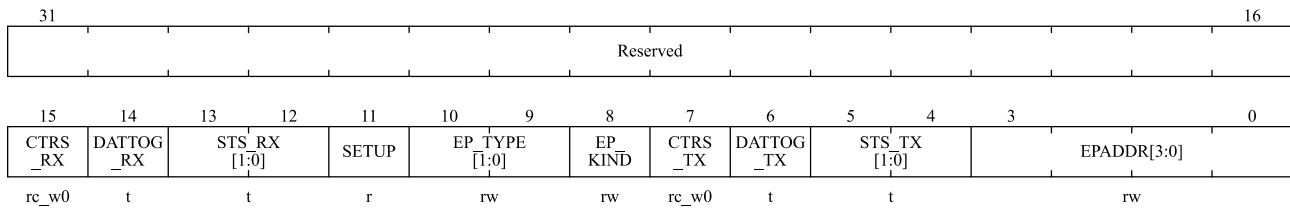

| Bit Field | Name        | Description   |
|-----------|-------------|---|
| 31: 16    | Reserved    | Reserved, the reset value must be maintained.   |
| 15        | CTRS_RX     | <p>Correct receive flag</p> <p>This bit is set by hardware when an OUT or SETUP transaction on this endpoint completes successfully. If USB_CTRL.CTRSM = 1, the corresponding interrupt will be generated.</p> <p><i>Note:</i></p> <p>1、 Software can read and write this bit, but only writing 0 is valid, and writing 1 is invalid.</p>   |
| 14        | DATTOG_RX   | <p>Receive data PID toggle bit</p> <p>If the endpoint is not isochronous, this bit represents the toggle data bit (0 = DATA0, 1 = DATA1).</p> <p>Double-buffered endpoint, this bit is used to implement the flow control mechanism for double-buffered endpoints.</p> <p>Isochronous endpoint, this bit is used for double buffer exchange.</p> <p><i>Note:</i></p> <p>1、 Software can read and write this bit, but writing 0 is invalid, and writing 1 toggles this bit.</p> <p>2、 Control endpoint, the hardware clears this bit after the USB module correctly receives the PID SETUP token packet.</p> <p>3、 In isochronous transfer, hardware toggles this bit just after the end of data packet reception.</p> |
| 13: 12    | STS_RX[1:0] | <p>Receive status</p> <p>This bit indicates the current state of the endpoint, Table 19-6 lists the available states of the endpoint. Hardware sets this bit to the NAK state when a correct OUT or SETUP transaction completes.</p> <p><i>Note:</i></p> <p>1、 Software can read and write this bit, but writing 0 is invalid, and writing 1 toggles this bit.</p> <p>2、 Double-buffered bulk endpoint, which controls the transmission status according to the buffer status used, refer to section 19.4.3.</p> <p>3、 Isochronous endpoint, the hardware will not change the state of the endpoint after the transaction is successfully completed</p>   |
| 11        | SETUP       | <p>SETUP transfer completion flag</p> <p>This bit is set by hardware when the USB module correctly receives the PID SETUP token packet.</p> <p><i>Note:</i></p> <p>1、 Software can only read this bit, not write this bit.</p>  |

| Bit Field    | Name         | Description  |              |  |                 |    |      |                                   |    |         |                           |    |     |                           |    |           |                               |
|--------------|--------------|--|--------------|--|-----------------|----|------|-----------------------------------|----|---------|---------------------------|----|-----|---------------------------|----|-----------|-------------------------------|
|              |              | 2、 This bit <i>USB_EPn.SETUP</i> is only valid for control endpoints.  |              |  |                 |    |      |                                   |    |         |                           |    |     |                           |    |           |                               |
| 10: 9        | EP_TYPE[1:0] | Endpoint type <table border="1" data-bbox="593 320 1426 533"> <thead> <tr> <th colspan="2">EP_TYPE[1:0]</th> <th>Description</th> </tr> </thead> <tbody> <tr> <td>00</td> <td></td> <td>BULK: bulk endpoint</td> </tr> <tr> <td>01</td> <td></td> <td>CONTROL: control endpoint</td> </tr> <tr> <td>10</td> <td></td> <td>ISO: isochronous endpoint</td> </tr> <tr> <td>11</td> <td></td> <td>INTERRUPT: interrupt endpoint</td> </tr> </tbody> </table>   | EP_TYPE[1:0] |  | Description     | 00 |      | BULK: bulk endpoint               | 01 |         | CONTROL: control endpoint | 10 |     | ISO: isochronous endpoint | 11 |           | INTERRUPT: interrupt endpoint |
| EP_TYPE[1:0] |              | Description  |              |  |                 |    |      |                                   |    |         |                           |    |     |                           |    |           |                               |
| 00           |              | BULK: bulk endpoint  |              |  |                 |    |      |                                   |    |         |                           |    |     |                           |    |           |                               |
| 01           |              | CONTROL: control endpoint  |              |  |                 |    |      |                                   |    |         |                           |    |     |                           |    |           |                               |
| 10           |              | ISO: isochronous endpoint  |              |  |                 |    |      |                                   |    |         |                           |    |     |                           |    |           |                               |
| 11           |              | INTERRUPT: interrupt endpoint  |              |  |                 |    |      |                                   |    |         |                           |    |     |                           |    |           |                               |
| 8            | EP_KIND      | Endpoint special type <table border="1" data-bbox="593 577 1426 790"> <thead> <tr> <th colspan="2">EP_TYPE[1:0]</th> <th>EP_KIND meaning</th> </tr> </thead> <tbody> <tr> <td>00</td> <td>BULK</td> <td>DBL_BUF: double buffered endpoint</td> </tr> <tr> <td>01</td> <td>CONTROL</td> <td>STATUS_OUT</td> </tr> <tr> <td>10</td> <td>ISO</td> <td>Undefined</td> </tr> <tr> <td>11</td> <td>INTERRUPT</td> <td>Undefined</td> </tr> </tbody> </table>   | EP_TYPE[1:0] |  | EP_KIND meaning | 00 | BULK | DBL_BUF: double buffered endpoint | 01 | CONTROL | STATUS_OUT                | 10 | ISO | Undefined                 | 11 | INTERRUPT | Undefined                     |
| EP_TYPE[1:0] |              | EP_KIND meaning  |              |  |                 |    |      |                                   |    |         |                           |    |     |                           |    |           |                               |
| 00           | BULK         | DBL_BUF: double buffered endpoint  |              |  |                 |    |      |                                   |    |         |                           |    |     |                           |    |           |                               |
| 01           | CONTROL      | STATUS_OUT   |              |  |                 |    |      |                                   |    |         |                           |    |     |                           |    |           |                               |
| 10           | ISO          | Undefined  |              |  |                 |    |      |                                   |    |         |                           |    |     |                           |    |           |                               |
| 11           | INTERRUPT    | Undefined  |              |  |                 |    |      |                                   |    |         |                           |    |     |                           |    |           |                               |
| 7            | CTRS_TX      | Correct send flag<br>This bit is set by hardware when an IN transaction on this endpoint completes successfully. If <i>USB_CTRL.CTRSM</i> = 1, the corresponding interrupt will be generated.<br><i>Note:</i><br>1、 Software can read and write this bit, but only writing 0 is valid, and writing 1 is invalid.   |              |  |                 |    |      |                                   |    |         |                           |    |     |                           |    |           |                               |
| 6            | DATTOG_TX    | Send data PID toggle bit<br>If the endpoint is not isochronous, this bit represents the toggle data bit (0 = DATA0, 1 = DATA1).<br>Double-buffered endpoint, this bit is used to implement the flow control mechanism for double-buffered endpoints.<br>Isochronous endpoint, this bit is used for double buffer exchange.<br><i>Note:</i><br>1、 Software can read and write this bit, but writing 0 is invalid, and writing 1 toggles this bit.<br>2、 Control endpoint, the hardware will set this bit after the USB module correctly receives the PID SETUP token packet.<br>3、 In isochronous transfer, hardware toggles this bit just after the end of data packet transmission. |              |  |                 |    |      |                                   |    |         |                           |    |     |                           |    |           |                               |
| 5: 4         | STS_TX[1:0]  | Send status<br>This bit indicates the current state of the endpoint, Table 19-7 lists the available states of the endpoint. When a correct IN transaction completes, the hardware sets this bit to the NAK state.<br><i>Note:</i><br>1、 Software can read and write this bit, but writing 0 is invalid, and writing 1 toggles this bit.<br>2、 Double-buffered bulk endpoint, which controls the transmission status according to the buffer status used, refer to section 19.4.3.<br>3、 Isochronous endpoint, the hardware will not change the state of the endpoint   |              |  |                 |    |      |                                   |    |         |                           |    |     |                           |    |           |                               |

| Bit Field | Name        | Description  |
|-----------|-------------|--|
|           |             | <i>after the transaction is successfully completed.</i>  |
| 3: 0      | EPADDR[3:0] | Endpoint address<br>This bit indicates the destination endpoint of the communication and must be written before enabling the corresponding endpoint. |

Note:

- 1、 When the USB module receives the USB bus reset signal, or  $USB\_CTRL.FRST = 1$ , the USB module will be reset. Except for the  $CTRS\_RX$  and  $CTRS\_TX$  bits that remain unchanged to process the following USB transfer, all other bits are reset.

Table 19-6 Receive status code

| STS_RX[1:0] | Description   |
|-------------|---|
| 00          | DISABLED: ignore all receive requests for this endpoint |
| 01          | STALL: the status of the handshake packet is STALL      |
| 10          | NAK: the status of the handshake packet is NAK          |
| 11          | VALID: endpoints can be used to receive                 |

Table 19-7 Send status code

| STS_TX[1:0] | Description  |
|-------------|--|
| 00          | DISABLED: ignore all send requests for this endpoint |
| 01          | STALL: the status of the handshake packet is STALL   |
| 10          | NAK: the status of the handshake packet is NAK       |
| 11          | VALID: endpoints can be used to send                 |

### 19.5.3 USB control register (USB\_CTRL)

Address offset: 0x40

Reset value: 0x0000 0003

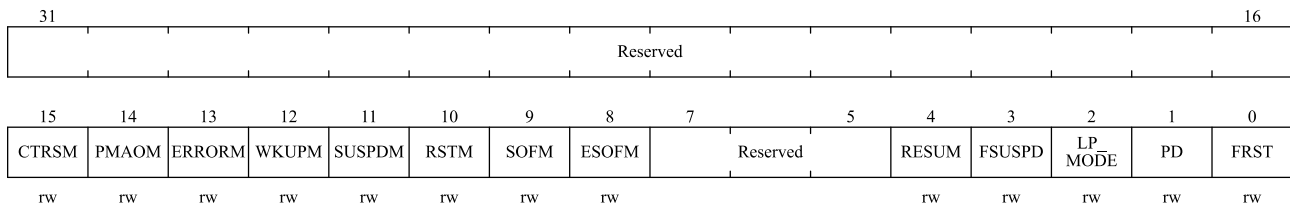

| Bit Field | Name     | Description   |
|-----------|----------|---|
| 31:16     | Reserved | Reserved, the reset value must be maintained.   |
| 15        | CTRSM    | Correct transfer interrupt enable<br>0: Disable correct transfer interrupt<br>1: Enable correct transfer interrupt, when $USB\_STS.CTRS = 1$ , an interrupt is generated. |
| 14        | PMAOM    | Packet buffer overflow/underflow interrupt enable<br>0: Disable packet buffer overflow/underflow interrupt  |

| Bit Field | Name     | Description  |
|-----------|----------|--|
|           |          | 1: Enable packet buffer overflow/underflow interrupt, when USB_STS.PMAO = 1, an interrupt is generated.  |
| 13        | ERRORM   | Error interrupt enable<br>0: Disable error interrupt<br>1: Enable error interrupt, when USB_STS.ERROR = 1, an interrupt will be generated.   |
| 12        | WKUPM    | Wake-up interrupt enable<br>0: Disable wake-up interrupt<br>1: Enable wake-up interrupt, when USB_STS.WKUP = 1, an interrupt will be generated.  |
| 11        | SUSPDM   | Suspend mode interrupt enable<br>0: Disable suspend mode interrupt<br>1: Enable suspend mode interrupt, when USB_STS.SUSPD = 1, an interrupt will be generated.  |
| 10        | RSTM     | USB reset interrupt enable<br>0: Disable USB reset interrupt<br>1: Enable USB reset interrupt, when USB_STS.RST = 1, an interrupt will be generated.   |
| 9         | SOFM     | Start of frame interrupt enable<br>0: Disable start of frame interrupt<br>1: Enable start of frame interrupt, when USB_STS.SOF = 1, an interrupt will be generated.  |
| 8         | ESOFM    | Expected start of frame interrupt enable<br>0: Disable the expected start of frame interrupt<br>1: Enable the expected start of frame interrupt, when USB_STS.ESOF = 1, generate an interrupt.   |
| 7: 5      | Reserved | Reserved, the reset value must be maintained.  |
| 4         | RESUM    | Resume request<br>0: No resume request<br>1: Send a resume request to the PC host<br><i>Note:</i><br>1、 If <code>USB_CTRL.RESUM = 1</code> remains active for 1ms to 15ms, the PC host will implement a resume operation for the USB module.   |
| 3         | FSUSPD   | Force suspend<br>Software must set this bit when the USB_STS.SUSPD interrupt is triggered.<br>0: Suspend mode not entered<br>1: Enter suspend mode, but the clock and static power consumption of the USB analog transceiver are still present<br><i>Note:</i><br>1、 To enter the low power consumption mode (bus powered device), the software must first set <code>USB_CTRL.FSUSPD</code> , and then set <code>USB_CTRL.LP_MODE</code> . |
| 2         | LP_MODE  | Low power mode<br>0: No effect<br>1: Enter low power mode in suspend mode. Activity on the USB bus (wake event)  |

| Bit Field | Name | Description   |
|-----------|------|---|
|           |      | resets this bit (software can also reset this bit)<br><i>Note:</i><br>1、 In low power mode, only the external pull-up resistor is used for power supply, and the system clock will also be stopped or reduced to a certain frequency to reduce power consumption.         |
| 1         | PD   | Power-down mode<br>0: Exit power-down mode<br>1: Enter power-down mode<br><i>Note:</i><br>1、 When <code>USB_CTRL.PD = 1</code> , the USB module is completely shut down, disconnected from the host, and the USB module will not work.                                    |
| 0         | FRST | Force USB reset<br>0: No effect<br>1: Reset the USB module, if <code>USB_CTRL.RSTM = 1</code> , a reset interrupt will be generated<br><i>Note:</i><br>1、 When <code>USB_CTRL.FRST = 1</code> , the USB module will remain in reset state until software clears this bit. |

### 19.5.4 USB interrupt status register (USB\_STS)

Address offset: 0x44

Reset value: 0x0000 0000

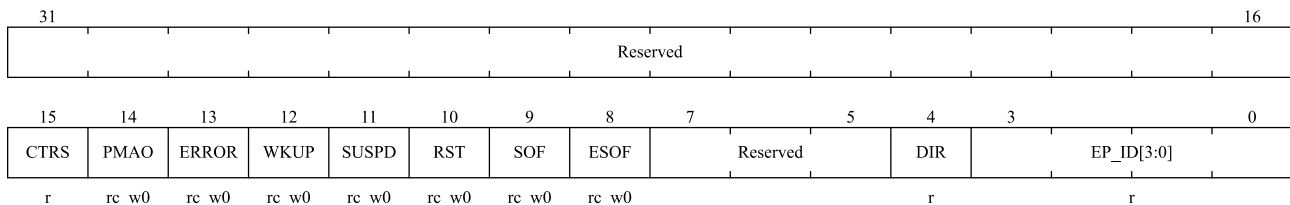

| Bit Field | Name     | Description  |
|-----------|----------|--|
| 31:16     | Reserved | Reserved, the reset value must be maintained.  |
| 15        | CTRS     | Correct transmission interrupt flag<br>Set by hardware when the endpoint has completed a data transfer correctly.<br><i>Note:</i><br>1、 Software can only read this bit, not write this bit.   |
| 14        | PMAO     | Packet buffer overflow/underflow interrupt flag<br>This bit is set by hardware when the packet buffer cannot hold all the transmitted data.<br><i>Note:</i><br>1、 Software can read and write this bit, but only writing 0 is valid, and writing 1 is invalid.<br>2、 This interrupt will not be generated during isochronous transfer. |

| Bit Field | Name  | Description   |
|-----------|-------|---|
| 13        | ERROR | <p>Error interrupt flag</p> <p>Hardware sets this bit when the following errors occur:</p> <ol style="list-style-type: none"> <li>1) No response, the host response timed out</li> <li>2) CRC error, CRC check error in data or token packet</li> <li>3) Bit stuffing error, bit stuffing error detected in PID, data or CRC</li> <li>4) Frame format error, non-standard frame received</li> </ol> <p><i>Note:</i></p> <ol style="list-style-type: none"> <li>1、 Software can read and write this bit, but only writing 0 is valid, writing 1 is invalid.</li> </ol> |
| 12        | WKUP  | <p>Wake-up interrupt flag</p> <p>In the suspend state, when the wake-up signal is detected, the hardware sets this bit, and the hardware resets the USB_CTRL.LP_MODE bit at the same time.</p> <p><i>Note:</i></p> <ol style="list-style-type: none"> <li>1、 Software can read and write this bit, but only writing 0 is valid, writing 1 is invalid.</li> </ol>  |
| 11        | SUSPD | <p>Suspend mode interrupt flag</p> <p>This bit is set by hardware when there is no activity on the USB bus for more than 3ms, indicating a suspend request.</p> <p><i>Note:</i></p> <ol style="list-style-type: none"> <li>1、 Software can read and write this bit, but only writing 0 is valid, and writing 1 is invalid.</li> <li>2、 In suspend mode, the USB hardware will not detect the suspend signal until the wake-up is over.</li> <li>3、 After the USB is reset, the hardware will immediately enable the detection of the suspend signal.</li> </ol>       |
| 10        | RST   | <p>USB reset interrupt flag</p> <p>This bit is set by hardware when a USB reset signal is detected.</p> <p><i>Note:</i></p> <ol style="list-style-type: none"> <li>1、 Software can read and write this bit, but only writing 0 is valid, and writing 1 is invalid.</li> <li>2、 When the USB reset interrupt is generated, the address and endpoint registers of the device will be reset, but the configuration registers will not be reset unless cleared by software.</li> </ol>  |
| 9         | SOF   | <p>Start of frame interrupt flag</p> <p>This bit is set by hardware when a PID SOF token packet is detected on the USB bus.</p> <p><i>Note:</i></p> <ol style="list-style-type: none"> <li>1、 Software can read and write this bit, but only writing 0 is valid, and writing 1 is invalid.</li> </ol>   |
| 8         | ESOF  | <p>Expected start of frame interrupt flag</p> <p>This bit is set by hardware when the USB module does not receive the expected PID SOF token packet.</p> <p><i>Note:</i></p> <ol style="list-style-type: none"> <li>1、 Software can read and write this bit, but only writing 0 is valid, and writing 1 is</li> </ol>   |

| Bit Field | Name       | Description   |
|-----------|------------|---|
|           |            | <i>invalid.</i><br>2、 When the USB module does not receive the PID SOF token packet for 3ms in a row, that is, 3 ESOFF interrupts occur in a row, and a SUSPDI interrupt will be generated.   |
| 7: 5      | Reserved   | Reserved, the reset value must be maintained.   |
| 4         | DIR        | Transmission direction<br>0: IN packet transfer is completed, and USB_EPn.CTRS_TX is set by hardware<br>1: OUT packet transfer is complete, and USB_EPn.CTRS_RX is set by hardware<br><i>Note:</i><br>1、 Software can only read this bit, not write this bit.<br>2、 When USB_EPn.CTRS_TX and USB_EPn.CTRS_RX are set at the same time, it indicates that there are OUT group and IN group at the same time.   |
| 3: 0      | EP_ID[3:0] | Endpoint number<br>After the USB module completes the data transmission and generates an interrupt, it is written by the hardware according to the endpoint number of the interrupt request.<br><i>Note:</i><br>1、 Software can only read this bit, not write this bit.<br>2、 When multiple endpoint requests are interrupted at the same time, the hardware writes the endpoint number with the highest priority. Isochronous endpoints and double-buffered bulk endpoints have high priority, other endpoints have low priority (the lower the endpoint number, the higher the priority). |

### 19.5.5 USB frame number register (USB\_FN)

Address offset: 0x48

Reset value: 0x0000 0XXX, X stands for undefined value

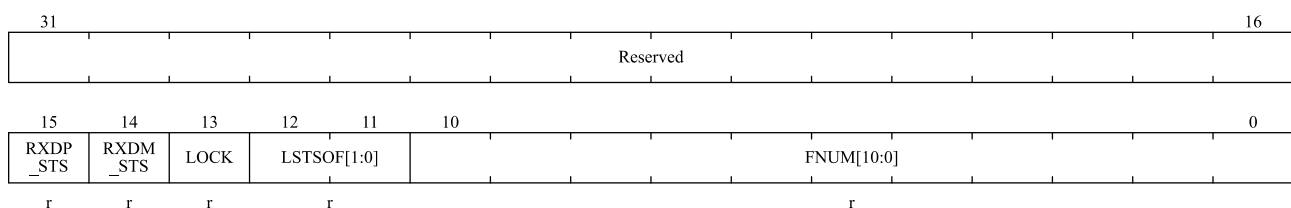

| Bit Field | Name     | Description   |
|-----------|----------|---|
| 31:16     | Reserved | Reserved, the reset value must be maintained.   |
| 15        | RXDP_STS | D+ status<br>Represents the state of the USB D+ line, and can detect the occurrence of a resume condition in the suspend state. |
| 14        | RXDM_STS | D- status<br>Represents the state of the USB D- line, and can detect the occurrence of a resume condition in the suspend state. |
| 13        | LOCK     | Lock USB<br>This bit is set by hardware if at least 2 PID SOF token packets are detected  |

| Bit Field | Name         | Description   |
|-----------|--------------|---|
|           |              | continuously after the end of an USB reset condition or after the end of an USB resume sequence.<br><i>Note:</i><br>1、 When <code>USB_FN.LOCK = 1</code> , the frame counter will stop counting before the USB module is reset or the USB bus is suspended. |
| 12:11     | LSTSOFF[1:0] | Lost SOF flag<br>The hardware increments this bit every time the <code>USB_STS.EEOF</code> event occurs, and once the PID SOF token packet is received, the hardware clears this bit.   |
| 10:0      | FNUM[10:0]   | Number of frames<br>Hardware increments this bit every time the USB module receives a PID SOF token packet.   |

### 19.5.6 USB device address register (USB\_ADDR)

Address offset: 0x4C

Reset value: 0x0000 0000

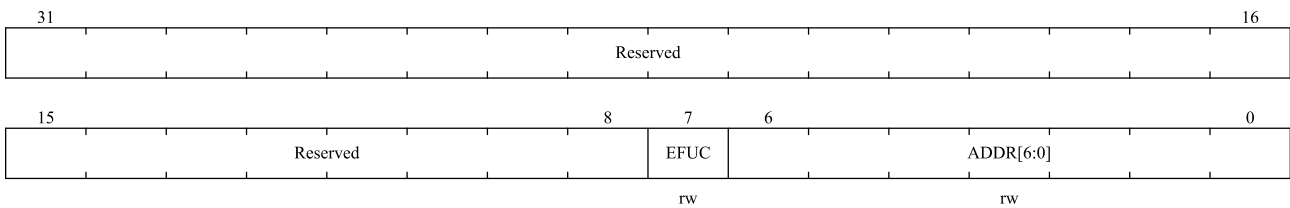

| Bit Field | Name      | Description   |
|-----------|-----------|---|
| 31:8      | Reserved  | Reserved, the reset value must be maintained.   |
| 7         | EFUC      | USB module enable<br>0: The USB module stops working and does not respond to any USB communication<br>1: Enable USB module  |
| 6: 0      | ADDR[6:0] | USB device address<br>This bit holds the address value assigned to the USB device by the USB host during enumeration. After a USB bus reset, this bit is reset to 0x00. |

### 19.5.7 USB packet buffer description table address register (USB\_BUFTAB)

Address offset: 0x50

Reset value: 0x0000 0000

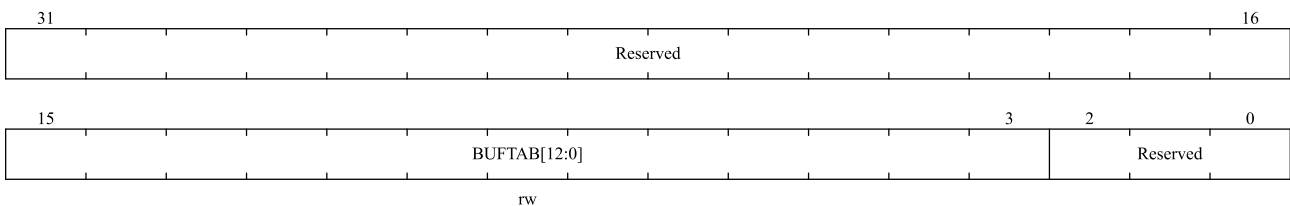

| Bit Field | Name         | Description  |
|-----------|--------------|--|
| 31:16     | Reserved     | Reserved, the reset value must be maintained.  |
| 15:3      | BUFTAB[12:0] | Buffer table<br>This bit holds the starting address of the buffer description table. The buffer description table is used to indicate the address and size of the endpoint packet buffer of each endpoint, aligned by 8 bytes (the lowest 3 bits are 000). |
| 2:0       | Reserved     | Reserved, the reset value must be maintained.  |

## 19.6 Buffer description table

The buffer description table is located in the packet buffer memory and is used to configure the address and size of the endpoint packet buffer shared by the USB module and the microcontroller core. Since the APB1 bus is addressed by 32 bits, the data packet buffer memory addresses use 32-bit aligned addresses, not the addresses used by the USB\_BUFTAB register and the buffer description table.

### 19.6.1 Send buffer address register n (USB\_ADDRn\_TX)

Address offset: [USB\_BUFTAB] + n×16

USB local address: [USB\_BUFTAB] + n×8

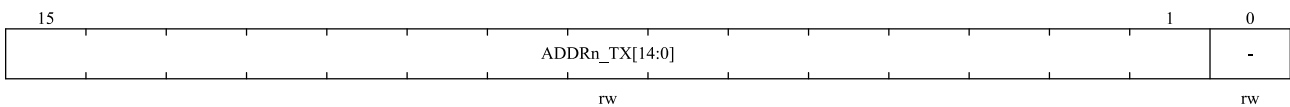

| Bit Field | Name           | Description   |
|-----------|----------------|---|
| 15: 1     | ADDRn_TX[14:0] | Send buffer address<br>The starting address of the endpoint packet buffer of the endpoint that needs to send data when the next PID IN token packet is received |
| 0         | -              | Since packet buffer memory addresses are word (32-bit) aligned, this bit must be 0  |

### 19.6.2 Send data byte number register n (USB\_CNTn\_TX)

Address offset: [USB\_BUFTAB] + n×16 + 4

USB local address: [USB\_BUFTAB] + n×8 + 2

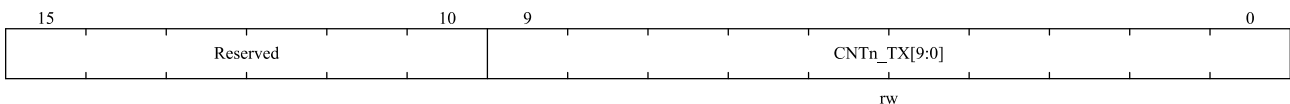

| Bit Field | Name         | Description  |
|-----------|--------------|--|
| 15:10     | Reserved     | Reserved, the reset value must be maintained.  |
| 9: 0      | CNTn_TX[9:0] | Number of bytes sent<br>The number of data bytes to send on the next PID IN token packet |

*Note: As shown in Table 19-2 and Table 19-3, the double-buffered IN endpoint and the isochronous IN endpoint require two USB\_CNTn\_TX registers: USB\_CNTn\_TX\_0 and USB\_CNTn\_TX\_1.*

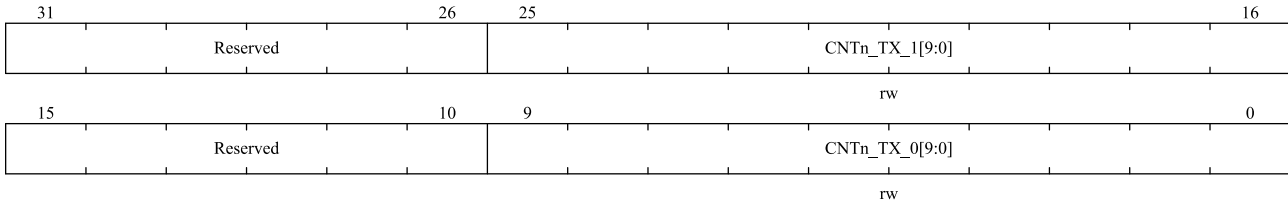

### 19.6.3 Receive buffer address register n (USB\_ADDRn\_RX)

Address offset: [USB\_BUFTAB] + n×16 + 8

USB local address: [USB\_BUFTAB] + n×8 + 4

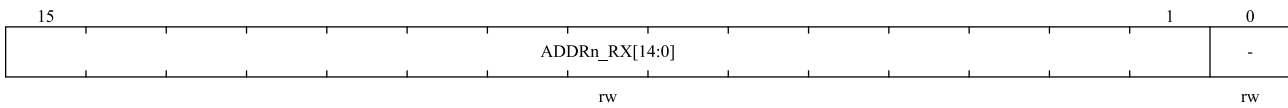

| Bit Field | Name           | Description  |
|-----------|----------------|--|
| 15:1      | ADDRn_RX[14:0] | Receive buffer address<br>Endpoint packet buffer start address for the endpoint to hold data when the next PID SETUP or OUT token packet is received |
| 0         | -              | Since packet buffer memory addresses are word (32-bit) aligned, this bit must be 0   |

### 19.6.4 Receive data byte number register n (USB\_CNTn\_RX)

Address offset: [USB\_BUFTAB] + n×16 + 12

USB local address: [USB\_BUFTAB] + n×8 + 6

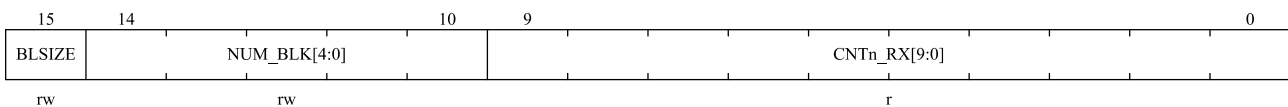

| Bit Field | Name         | Description  |
|-----------|--------------|--|
| 15        | BLSIZE       | Memory block size<br>0: The memory block size is 2 bytes<br>1: The memory block size is 32 bytes   |
| 14:10     | NUM_BLK[4:0] | Number of memory blocks<br>Records the number of memory blocks allocated to the endpoint packet receive buffer and determines the size of the endpoint packet receive buffer that is ultimately used. For details, please refer to the following Table 19-8. |
| 9:0       | CNTn_RX[9:0] | Number of bytes received<br>Written by the USB module to record the actual number of bytes of the latest PID SETUP or OUT token packet received by the endpoint.   |

*Note: As shown in Table 19-2 and Table 19-3 double buffered OUT endpoints and isochronous OUT endpoints require two USB\_CNTn\_RX registers: USB\_CNTn\_RX\_0 and USB\_CNTn\_RX\_1.*

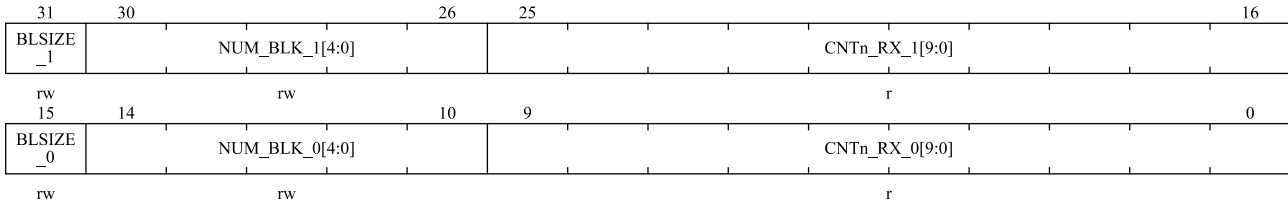

Table 19-8 Endpoint packet receive buffer size definition

| NUM_BLK[4:0] | BLSIZE = 0  | BLSIZE = 1 |
|--------------|-------------|------------|
| 00000        | Not allowed | 32 bytes   |
| 00001        | 2 bytes     | 64 bytes   |
| 00010        | 4 bytes     | 96 bytes   |
| 00011        | 6 bytes     | 128 bytes  |
| ...          | ...         | ...        |
| 01111        | 30 bytes    | 512 bytes  |
| 10000        | 32 bytes    | Reserved   |
| 10001        | 34 bytes    | Reserved   |
| 10010        | 36 bytes    | Reserved   |
| ...          | ...         | ...        |
| 11110        | 60 bytes    | Reserved   |
| 11111        | 62 bytes    | Reserved   |

*Note:*

- 1、 *The size of the endpoint packet receive buffer is defined during the device enumeration process and is defined by the `wMaxPacketSize` field of the standard endpoint descriptor in the USB 2.0 protocol specification.*

## 20 Controller area network (CAN)

### 20.1 Introduction to CAN

As CAN network interface, basic extended CAN supports CAN protocols 2.0A and 2.0B. It can efficiently process a large number of received messages and greatly reduce the consumption of CPU resources. The priority characteristics of message sending can be configured by software, and the hardware function of CAN can support time-triggered communication mode for some applications with high security requirements.

### 20.2 Main features of CAN

- Baud rate supports up to 1Mbit/s
- CAN protocol 2.0A/B are supported.
- Support time-triggered communication function
- Support individual interrupt control.
- CAN Core Manages the communication between the CAN and the 512 bytes SRAM memory (see Figure 20-3)
- Dual CAN: CAN1 and CAN2 each with 512 bytes of SRAM

*Note: USB and CAN1 share a single 512-byte SRAM. Since this SRAM is used to transmit and receive data, USB and CAN1 cannot be used at the same time. USB and CAN1 can be time-shared using in an application, but not simultaneously.*

#### Time triggered communication mode

- 16-bit free-running timer
- Automatic retransmission mode is prohibited.
- The last 2 data bytes of a message can be configured as the timestamp.

#### Send

- There are 3 sending mailboxes.
- Time stamp function for recording the time of sending SOF
- Software can configure the priority characteristics of sending messages.

#### Receive

- Filter groups support identifier list mode.
- Each CAN has two receiving FIFOs, each with a depth of 3 levels
- A total of 14 filter groups(each CAN module has its own)
- Configurable FIFO overrun handling method
- Time stamp function for recording the time of receiving SOF

## 20.3 CAN overall introduction

With the wide application of CAN, the nodes of CAN network are growing rapidly. Multiple CAN nodes are connected through CAN network. With increase number of CAN nodes, messages in CAN network also increase dramatically which will occupides lots of CPU resource. In this CAN controller, receive FIFOs and filter mechanism are added as hardware support for CPU message processing and reduce real-time response requirement of CAN message.

Figure 20-1 Topology of CAN network

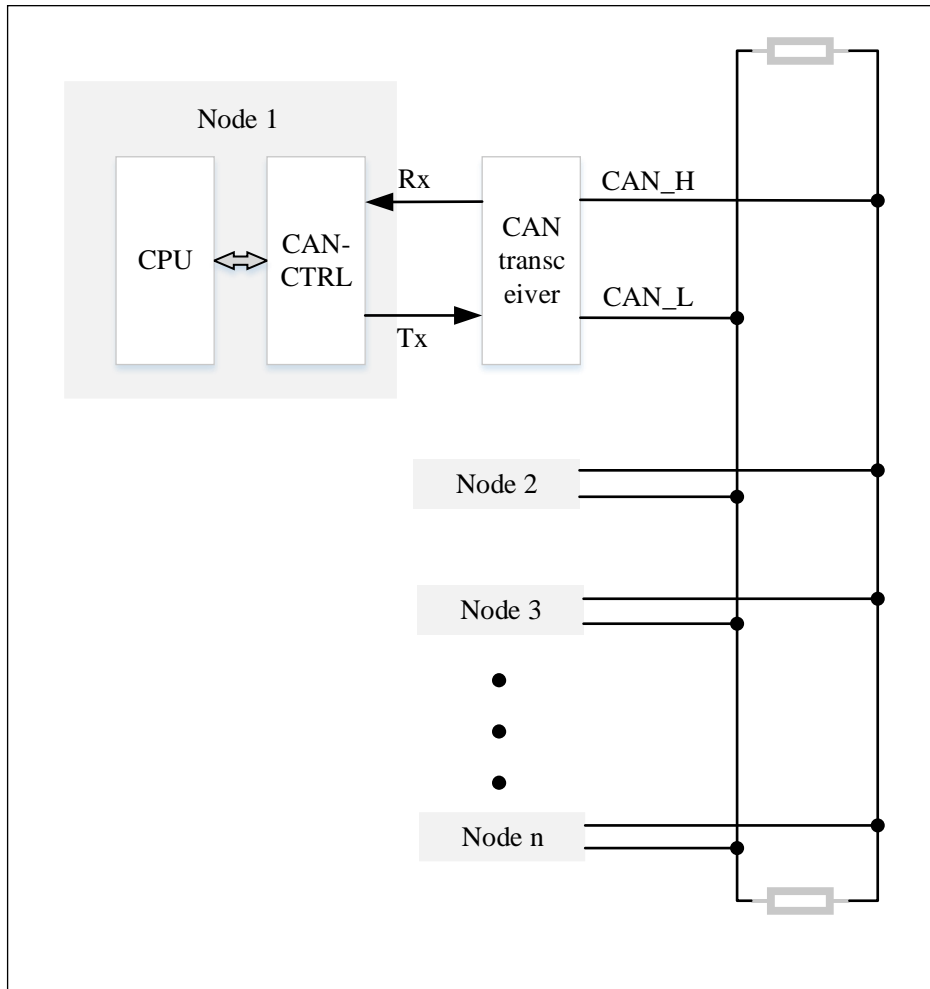

### 20.3.1 CAN module

CAN module can automatically receive and send CAN messages, and supports standard identifiers (11 bits) and extended identifiers (29 bits).

### 20.3.2 CAN working mode

Initialization, normal and sleep mode are three main working modes of CAN. The internal pull-up resistor of CANTX pin is activated after hardware reset, and CAN works in sleep mode to reduce power consumption.

The software can set `CAN_MCTRL.INIRQ` and `CAN_MCTRL.SLPRQ` bit to configure CAN to enter **initialization**

or **sleep** mode. The software reads values of the CAN\_MSTS.INIAK or CAN\_MSTS.SLPAK bit to confirm whether the **initialization** or **sleep** mode is entered, at this time the internal pull-up resistor of the CANTX pin is disabled.

CAN is in **normal** mode when CAN\_MSTS.INIAK and CAN\_MSTS.SLPAK bits are both '0', and it must **synchronize** with CAN bus to enter **normal** mode. When 11 consecutive recessive bits are monitored on the CANRX pin, the CAN bus is idle and synchronization is completed.

### 20.3.2.1 Normal mode

After the initialization is completed, the software configures CAN to enter normal mode. Clear the CAN\_MCTRL.INIRQ and wait for the hardware to clear the CAN\_MSTS.INIRQ bit to confirm that CAN enters normal mode. Only after the synchronization with CAN bus is completed, CAN can receive and send messages normally.

Setting the bit width and mode of the filter group must be completed when the filter is in the initialization mode (the CAN\_FMC.FINITM bit is 1). Setting the initial value of the filter must be completed when it is inactive (the corresponding CAN\_FA1.FAC bit is 0).

### 20.3.2.2 Initialization mode

The software can perform initialization configuration only when CAN is in initialization mode. Set the CAN\_MCTRL.INIRQ bit and clear CAN\_MCTRL.SLPRQ bit, and wait for the hardware to set the CAN\_MSTS.INIAK bit to confirm that CAN enters the initialization mode. When entering the initialization mode, the register configuration will not be affected. When CAN is in initialization mode, message receiving and sending are prohibited, and the CANTX pin outputs a recessive bit (high level). To exit initialization mode, clear the CAN\_MCTRL.INIRQ bit, and wait for the hardware to clear the CAN\_MSTS.INIAK bit to confirm that CAN exits the initialization mode.

To perform initialization configuration for CAN by software, at least the bit time characteristic register (CAN\_BTIM) and the control register (CAN\_MCTRL) need to be configured. The software needs to set the CAN\_FMC.FINITM bit to initialize the filter group (mode, bit width, FIFO association, activation and filter value) that configures CAN. Configuring the filter group of CAN does not necessarily need to be in initialization mode.

Specially, when CAN\_FMC.FINITM=1, it is forbidden to receive messages. If you want to modify the value of the corresponding filter, you need to first clear the filter activation bit (in CAN\_FA1). It is necessary to keep the unused filter group inactive (keep its CAN\_FA1.FAC bit to '0').

### 20.3.2.3 Sleep mode (low power)

To enter sleep mode, set the CAN\_MCTRL.SLPRQ bit, and wait for the hardware to set the CAN\_MSTS.SLPAK bit to confirm that CAN enters sleep mode. CAN can configure to sleep mode to reduce power consumption when unused. In sleep mode, the clock of CAN stops working, but the software can still access the sending/receiving mailbox register. When CAN is in sleep mode, the CAN\_MCTRL.INIRQ bit must be set and the CAN\_MCTRL.SLPRQ bit must be clear at the same time so as to enter the initialization mode.

There are two situations to wake up CAN (CAN exits sleep mode):

- When the CAN\_MCTRL.AWKUM bit is set (enable hardware wake up automatically), once the activity of the CAN bus is detected, the hardware will automatically clear the CAN\_MSTS.SLPRQ bit to wake up CAN.
- When the CAN\_MCTRL.AWKUM bit is clear (enable software wake up), and wake-up interrupt occurred, then

the software must clear the CAN\_MCTRL.SLPRQ bit to exit the sleep state.

If the wake-up interrupt (set the CAN\_INTE.WKUIE bit) is enabled, the wake-up interrupt will be generated once the CAN bus activity is detected, regardless of whether the hardware is enabled to automatically wake up CAN.

The CAN must be synchronized with the CAN bus before entering Normal mode Wait until the CAN\_MSTS.SLPAK bit cleared to confirm the sleep mode has exited. Please refer to Figure 20-2.

Figure 20-2 CAN working mode

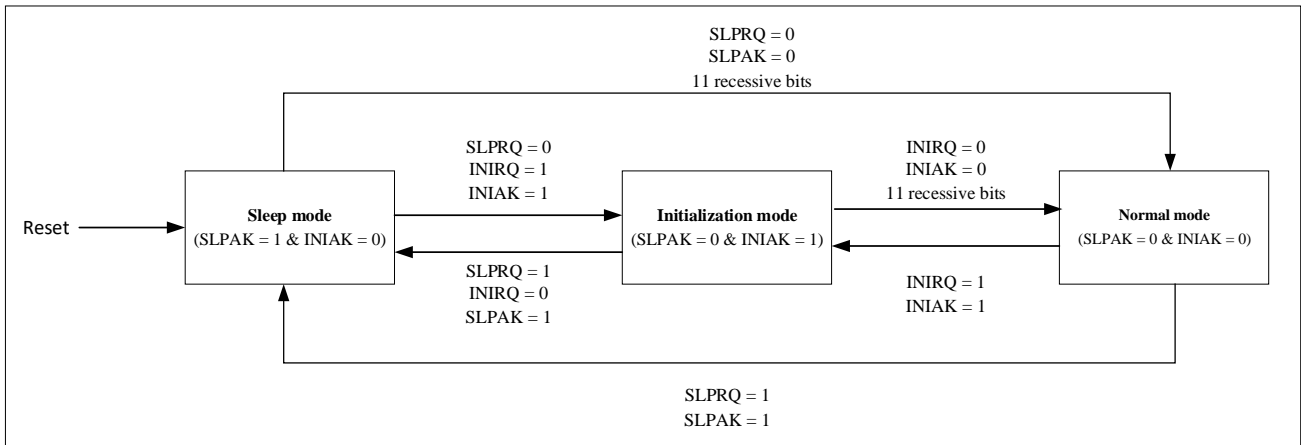

Notes: the state that the hardware sets the CAN\_MSTS.INIAK or CAN\_MSTS.SLPAK bit in response to a sleep or initialization request.

### 20.3.3 Send mailbox

Applications can send messages through three sending mailboxes. The order of sending three mailbox messages is determined by the sending scheduler according to the priority of the messages, and the priority can be determined by the identifier of the messages or by the order of sending requests.

### 20.3.4 Receiving filter

Each CAN has 14 configurable identifier filter groups. After the application configures the identifier filter group, the receiving mailbox will automatically receive the required messages and discard other messages.

### 20.3.5 Receive FIFO

Each CAN has two receiving FIFOs, each of which can store three complete messages. No application program is needed to manage it, and it is managed by hardware.

Figure 20-3 Dual CAN block diagram

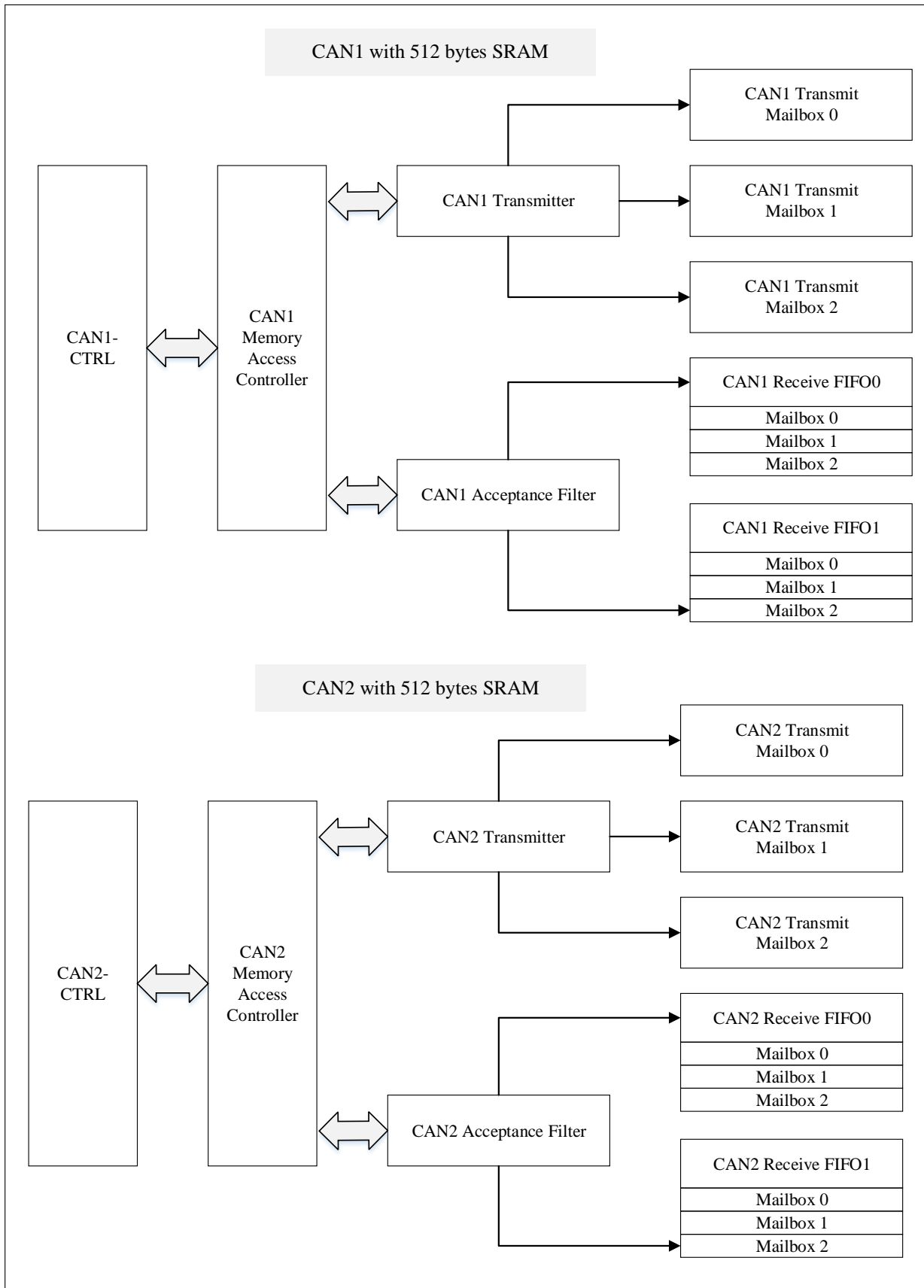

## 20.3.6 CAN Test mode

In the initialization mode, a test mode must be selected by combining the CAN\_BTIM.SLM bit and CAN\_BTIM.LBM bit. After selecting a test mode, the software needs to clear the CAN\_MCTRL.INIRQ bit to exit the initialization mode and enter the test mode.

### 20.3.6.1 Loopback mode

Loopback mode can be used for self-test. In loopback mode, CAN saves the sent message in the receiving mailbox as received message (if it can be filtered by reception). In loopback mode, CAN internally feeds back the Tx output to the Rx input, completely ignoring the actual state of the CANRX pin. The message sent can be detected on the CANTX pin. In order to avoid external influence, the CAN kernel ignores the acknowledgement error(at the moment of acknowledgement bit of data/remote frame, it does not detect whether there is an dominant bit). To enter loopback mode, the CAN\_BTIM.SLM bit should be cleared and the CAN\_BTIM.LBM bit should be set.

Figure 20-4 loopback mode

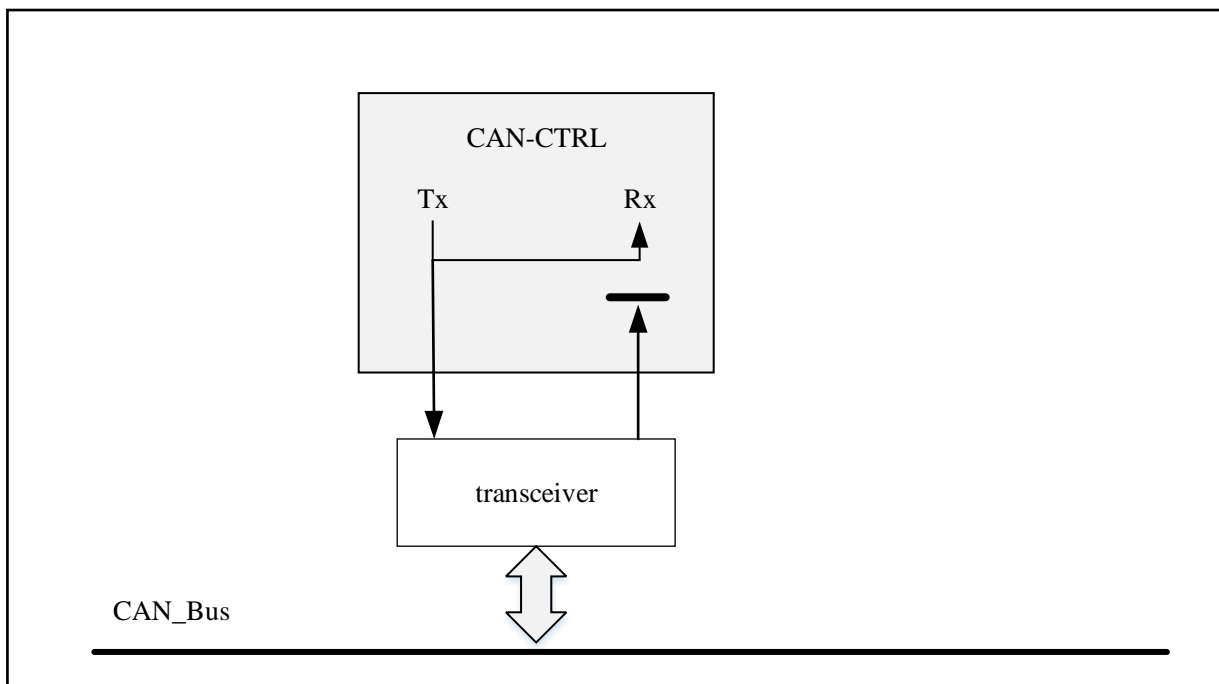

### 20.3.6.2 Silent mode

In silent mode, CAN can normally receive data frames and remote frames, but can only send recessive bits, and can't really send messages. If CAN needs to send overload flag, active error flag or ACK bit(these are dominant bits), such dominant bits are internally connected back so as to be detected by the CAN core. At the same time, the CAN bus will not be affected and still remain in the recessive bit state. Therefore, the silent mode is usually used to analyze the activity of the CAN bus, without affecting the bus because dominant bits is not actually sent to the bus.

To enter silent mode, the CAN\_BTIM.SLM bit should be set and the CAN\_BTIM.LBM bit should be cleared.

Figure 20-5 silent mode

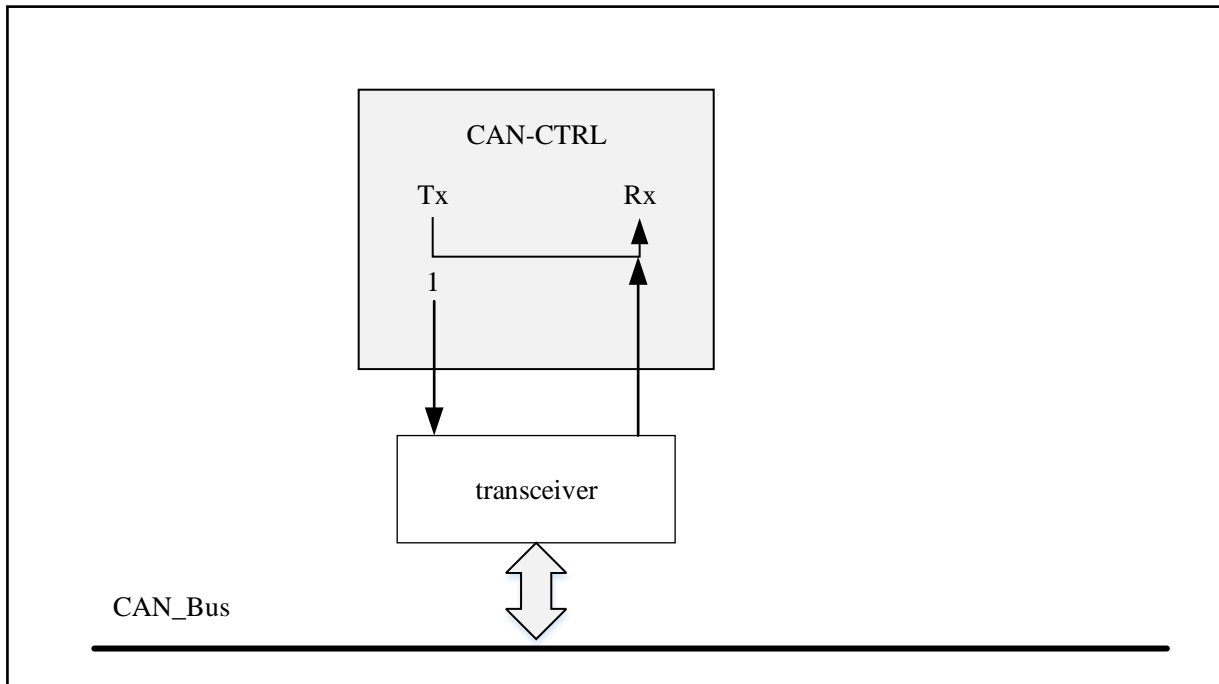

### 20.3.6.3 Loopback silence mode

In loopback silence mode, the CANRX pin is disconnected from the CAN bus, while the CANTX pin is driven to the recessive bit state. It can be used for "Run-time self diagnose" just like CAN can be tested in loop-back mode, but not affect the whole CAN system connected by CANTX and CANRX.

To enter loopback silence mode, both the CAN\_BTIM.SLM bit and the CAN\_BTIM.LBM bit should be set.

Figure 20-6 loopback silent mode

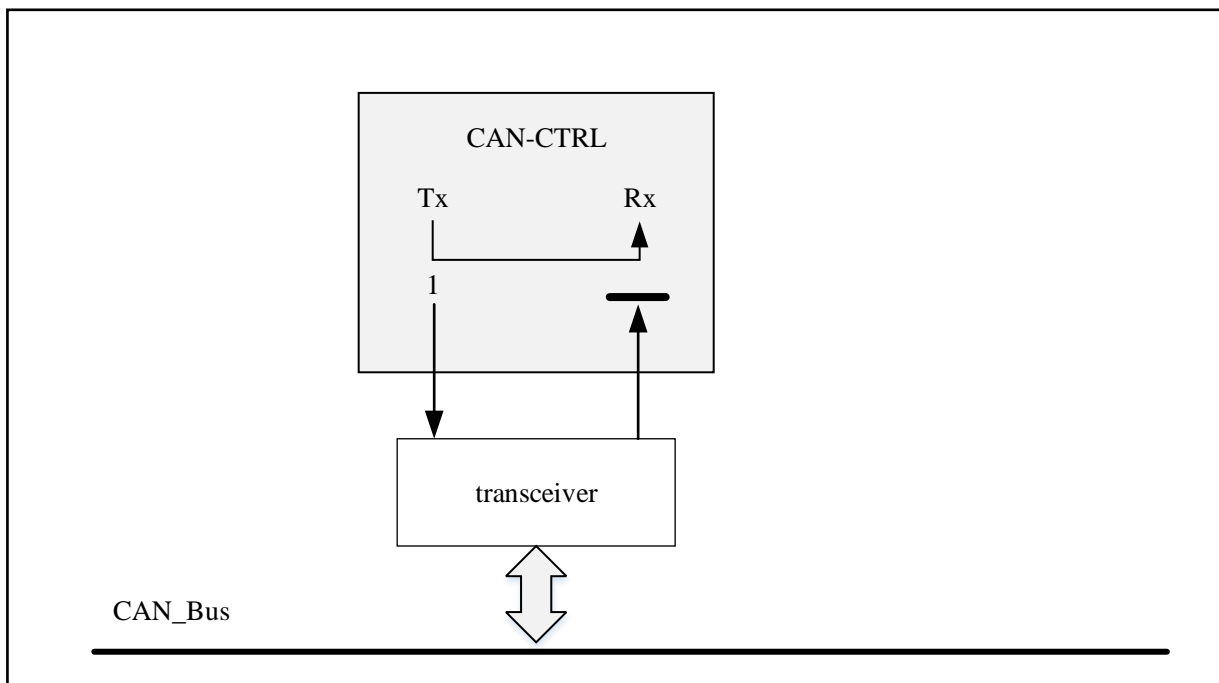

## 20.3.7 CAN Debugging mode

CAN can continue to work normally or stop working according to the state of the following configuration bits:

- `DBG_CTRL.CAN1_STOP` bit of CAN1 and `DBG_CTRL.CAN2_STOP` bit of CAN2 in the debug support(DBG) module. See paragraph 29.3.2 Section: Peripheral debugging support.
- `CAN_MCTRL.DBGF` bit see paragraph 20.7.3.1 Section: `CAN_MCTRL`.

When the microcontroller is in debug mode, Cortex-M4F core is in a suspended state.

## 20.4 CAN function description

### 20.4.1 Send processing

The process of sending messages is as follows:

- The application program selects an **empty** sending mailbox;
- Writes the identifier, data length and data to be sent in the sending mailbox register;
- Set the `CAN_TMIx.TXRQ` bit to request transmission (after `CAN_TMIx.TXRQ` is set the mailbox is no longer an empty mailbox and the software has no permission to write to the mailbox register);
- The mailbox enters the **pending** state and wait to be the highest priority, see 20.4.1.1 Send priority;
- Changing to the **Ready** status once the mailbox becomes the highest priority mailbox;
- The messages in the ready mailbox is sent as soon as the CAN bus enters the idle state, then enter the sending state.
- Become an **empty** mailbox when the message in the mailbox is successfully sent;
- Hardware set the `RQCPM` and `TXOKM` bits of the corresponding mailbox in `CAN_TSTS` register to indicate a successful transmission.

However, if the transmission fails, the `CAN_TSTS.ALSTM` bit will be set to indicate that the failure is caused by arbitration or the `CAN_TSTS.TERRM` bit will be set to indicate that it is caused by the transmission error (for specific errors, please check the `CAN_ESTS.LEC[2:0]` error code bits of the error status).

#### 20.4.1.1 Send priority

**Determined by the order of sending requests.**

Set the `CAN_MCTRL.TXFP` bit, and the sending mailbox can be configured as a sending FIFO. At this time, the priority of sending is determined by the order of sending requests. This mode is useful for segmented transmission.

**Determined by the identifier.**

According to CAN protocol, the message with the lowest identifier has the highest priority. If the values of identifiers are equal, the message with small mailbox number is sent first. When more than one sending mailbox is registered, the sending order is determined by the identifier of the message in the mailbox.

#### 20.4.1.2 Cancel sending

Set the `CAN_TSTS.ABRQM` bit can abort sending the request. If the mailbox is ready or pending, the sending request

will be aborted immediately. If the mailbox is in the transmitting state, the request to abort may lead to two kinds of results:

- if the message in the mailbox fails to be sent, the mailbox becomes ready state, then the sending request is aborted, the mailbox becomes an empty mailbox and the CAN\_TSTS.TXOKM bit is cleared;
- if the message in the mailbox is successfully sent, the mailbox becomes an empty mailbox, and the CAN\_TSTS.TXOKM bit will be set by hardware.

Therefore, when the sending mailbox is in the sending state, regardless of the sending result, the mailbox will become an empty mailbox after the sending operation is finished.

### 20.4.2 Time triggered communication mode

The internal timer of CAN is activated in time triggered communication mode. It is incremented at each CAN bit time (see 20.4.7 Section). CAN samples the value of the internal timer at the sampling point position of the received and sent frame start bits, and the sampled value is the time stamp of the sending and receiving mailboxes. Timestamps generate from the internal timer will be stored in the CAN\_RMDTx/CAN\_TMDTx registers respectively.

### 20.4.3 Non-automatic retransmission mode

To enable non-automatic retransmission mode the CAN\_MCTRL.NART bit should be set. This mode corresponds to the function of time-triggered communication option in CAN standard. In non-automatic retransmission mode, the sending operation will only be executed once. If the sending operation fails, whether due to arbitration loss or error, the hardware will not automatically send the message again. At the end of a transmission operation, the hardware judge that the transmission request has been completed, and the hardware sets the CAN\_TSTS.RQCPM bit. At the same time, the transmission result can query the CAN\_TSTS.TXOKM, CAN\_TSTS.ALSTM and CAN\_TSTS.TERRM bits.

Figure 20-7 Send mailbox status

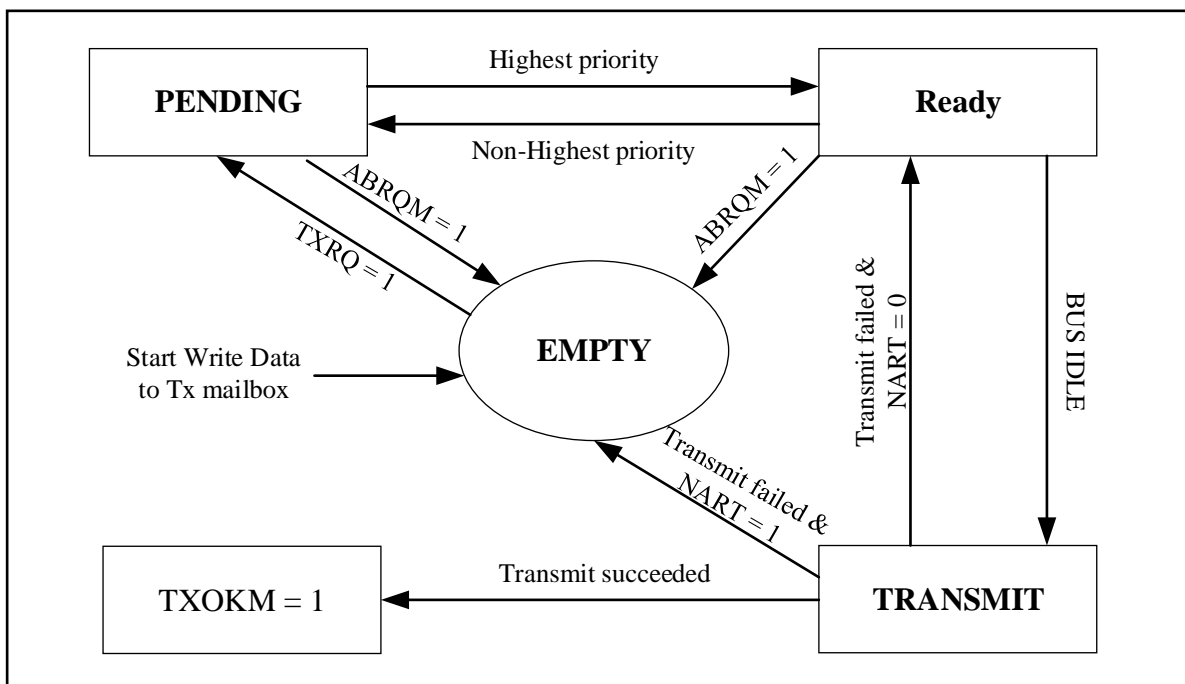

## 20.4.4 Receiving management

FIFOs with 3 levels depth are used to store received messages. When the application reads the FIFO output mailbox, it reads the first received message in the FIFO. FIFO is completely managed by hardware, which can simplify the application program, ensure the consistency of data and reduce the processing time of CPU.

### 20.4.4.1 Valid message

According to CAN protocol, when the message is correctly received (no errors are sent up to the last bit of the EOF field) and passes the identifier filtering, then the message is taken as a valid message. Please refer to 20.4.5 Section: identifier filtering.

Figure 20-8 Receive FIFO status

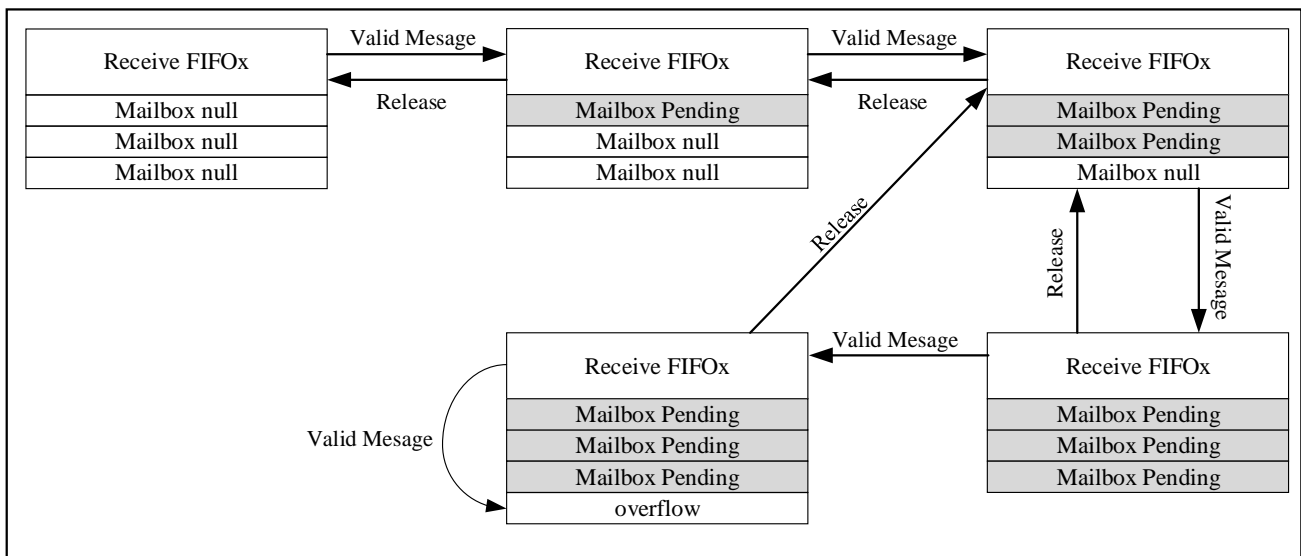

### 20.4.4.2 FIFO receive

A FIFO includes mailboxes with three levels of depth, and the initial state is empty. After receiving the first valid message, one of the mailboxes will be suspended, and the hardware will set the CAN\_RFF.FFMP[1:0] bits to 1 to indicate the receipt of a valid message. A valid message is received again before the mailbox is released. At this time, two mailboxes will be suspended at the same time, and the hardware will set the CAN\_RFF.FFMP[1:0] bits to 2 to indicate that two valid messages are pending. As above, the third valid message will suspend all three mailboxes and set the CAN\_RFF.FFMP[1:0] bits to 3.

When the three-level mailboxes of the FIFO are all suspended, receiving a valid message again will cause the mailbox to overflow and lose a message, and the hardware will set the CAN\_RFF.FFOVR bit to 1 to indicate the occurrence of the event. The rules for lost messages depend on the configuration of the FIFO. If the FIFO lock function is disabled (clear the CAN\_MCTRL.RFLM bit), then the last message received in the FIFO will be overwritten by the new message. In this way, the latest received message will not be discarded; If the FIFO lock function is enabled (set the CAN\_MCTRL.RFLM bit), then the newly received messages will be discarded, and the software can read the first three messages in the FIFO.

### 20.4.4.3 FIFO release

The message stored in the FIFO will be read through the corresponding receive mailbox. The software reads the mailbox message and releases the mailbox by setting the CAN\_RFR.RFOM bit to 1, and the CAN\_RFF.FFMP[1:0]

bit is decremented by 1 until it is 0.

#### 20.4.4.4 Receive related interrupts

The hardware will update the CAN\_RFF.FFMP[1:0] bits when a message is stored in the receiving FIFO. If the FIFO message pending interrupt is currently enabled (the CAN\_INTE.FMPITE bit is set), then the FIFO message pending interrupt request will be generated.

When the third message is stored, the FIFO becomes full, then the CAN\_RFF.FFULL bit will be set, and if the FIFO full interrupt is currently enabled (the CAN\_INTE.FFITE bit is set), a FIFO full interrupt request will be generated.

When the FIFO overrun, the FFOVR bit will be set. If the FIFO overrun interrupt is currently enabled (the CAN\_INTE.FOVITE bit is set), a FIFO overrun interrupt request will be generated.

#### 20.4.5 Identifier filtering

In the CAN network, when basic CAN is in the transmitter state, it broadcasts a message to each node by sending a message to the bus; when basic CAN is in the receiver state, it determines whether the node needs the message according to the identifier of the message after receiving the message. If message is valid, CAN core copies the message to SRAM(CAN's own SRAM); If it is not needed, the message will be discarded. This process does not require software intervention. Compared with software filtering, hardware filtering reduces the CPU usage. CAN controller provides 14 configurable filter banks (0~13) with variable bit width for application programs to meet this demand. These filter banks are used to receive only those messages needed by software. Each filter bank x contains two 32-bit registers, namely CAN\_FxR1 and CAN\_FxR2.

##### 20.4.5.1 Setting of filter bit width and mode

Each filter in a filter bank is numbered (filter number, from 0 to a certain maximum value) depending on the mode and bit width setting of the filter bank. See the figure below for the filter configuration. The filter group can be configured through the corresponding CAN\_FMC register. Filter banks that are not used by the application should be kept disabled. Before configuring a filter bank, it must be set to the disabled state by clearing the CAN\_FA1.FAC bit.

By setting the corresponding CAN\_FS1.FSCx bit you can configure the bit width of a filter bank, see Figure 20-9.

By means of the CAN\_FM1.FBx bit, the corresponding mask/identifier register can be configured to be the **identifier list** or **identifier mask** mode. The filter group should be set to work in the mask mode in order to filter out a group of identifiers. And the filter group should be set to work in identifier list mode in order to filter out an identifier.

Figure 20-9 Filter bit width setting-register organization

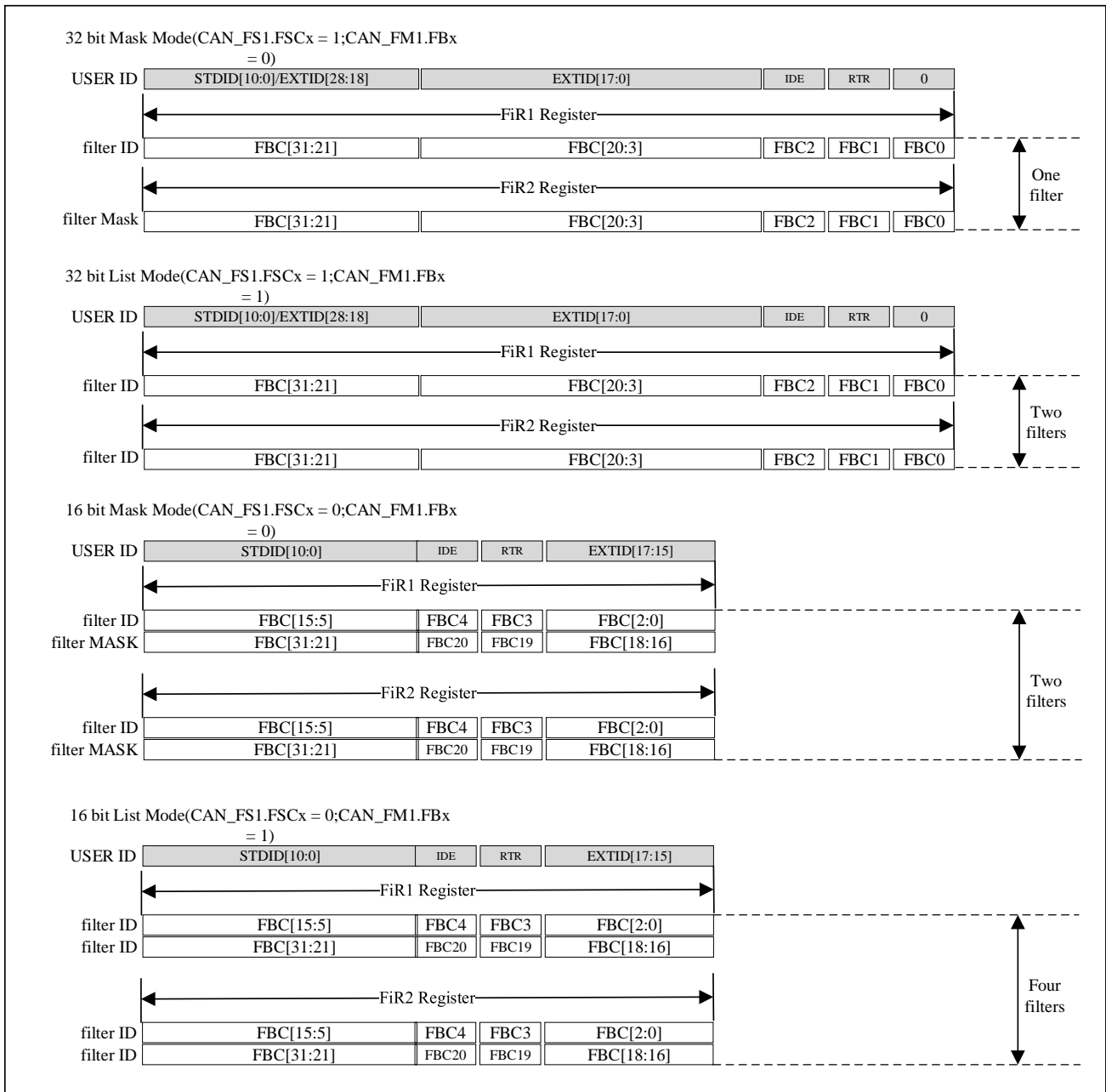

### 20.4.5.2 Variable bit width

The bit width of each filter bank can be independently configured. Each filter bank can be configured to be one 32-bit filter: including STDID[10:0], EXTID[17:0], IDE and RTRQ bits; or two 16-bit filters, including STDID[10:0], IDE, RTRQ and EXTID[17:15] bits, see Figure 20-9. In addition, the filter can be configured in two different modes, namely, the mask mode and the identifier list mode.

#### Mask mode

The filter ID is used to store the identifier format, and the filter MASK is used to indicate which bits must be checked and which bits can be ignored.

#### Identifier list mode

The filter ID is used to store the identifier format. At this time, there is no mask for comparison, and the mask bit can

be used to store one more filter ID. However, at this time, the identifier of the message needs to be exactly the same as the filter ID format, otherwise it will fail to pass the filter.

### 20.4.5.3 Filter matching sequence number

After CAN core received an valid message it will matching the message ID with filters one by one until there is one filter pass or all filters failed. If this message failed to pass any enabled filter then it will be discarded. Otherwise when CAN core finds the first filter that the ID can pass, it pack filter index with the CAN message and stores inside receive FIFO in SRAM according to filter setting (CAN\_FFA1 decides store in which FIFO). User can find filter index in FMI [7:0] bits of CAN\_RMDTx register. This filter matching index can help to identify which types of message it is in this receive FIFO.

The filter matching sequence number can be used two ways. The first one is comparing the filter matching sequence number with a series of expected values. The another is using the filter matching sequence number as an index to access the target address. When numbering filters, whether the filter group is active or not is not considered, default number of inactive filter group numbers is 2, and the default is FIFO0 filter number. In addition, each FIFO numbers its associated filter. Please refer to the example below.

For the filter in mask mode, the software only needs to compare the mask bits that are needed (bits that must be matched). For the filter in identifier list mode (non-screening filter), the software does not need to directly compare with the identifier.

Table 20-1 Examples of filter numbers

| Point to FIFOx | Filter group | Filter mode      | FIFO0 filter number |
|----------------|--------------|------------------|---------------------|
| FIFO           | 0            | 32 bit mask mode | 0                   |
|                | 2            | 16 bit mask mode | 1/2                 |
|                | 5            | 32 bit list mode | 3/4                 |
|                | 7            | 16 bit list mode | 5/6/7/8             |
|                | 9            | 32 bit list mode | 9/10                |
|                | 11           | 16 bit list mode | 11/12/13/14         |
|                | 13           | 32 bit mask mode | 15                  |
| Point to FIFOx | Filter group | Filter mode      | FIFO1 filter number |
| FIFO1          | 1            | 32 bit list mode | 0/1                 |
|                | 3            | 16 bit list mode | 2/3/4/5             |
|                | 4            | 32 bit mask mode | 6                   |
|                | 6            | 16 bit mask mode | 7/8                 |

|  |    |                  |       |
|--|----|------------------|-------|
|  | 8  | 32 bit mask mode | 9     |
|  | 10 | 16 bit mask mode | 10/11 |
|  | 12 | 32 bit list mode | 12/13 |

#### 20.4.5.4 Filter priority rule

According to different configurations of filters, it is possible that a message identifier can be filtered by multiple filters; In this case, the filter matching serial number stored in the receiving mailbox is first determined according to bit width, 32-bit-wide filters have higher priority than 16-bit-wide filters. For filters with the same bit width, then the identifier list mode takes precedence over the mask mode. If filters have the same bit width and mode, the priority is determined by the filter group number, and the filter group with lower number has the higher priority. Within a filter group, the lower the filter number, the higher the priority.

Figure 20-10 Examples of filter mechanisms

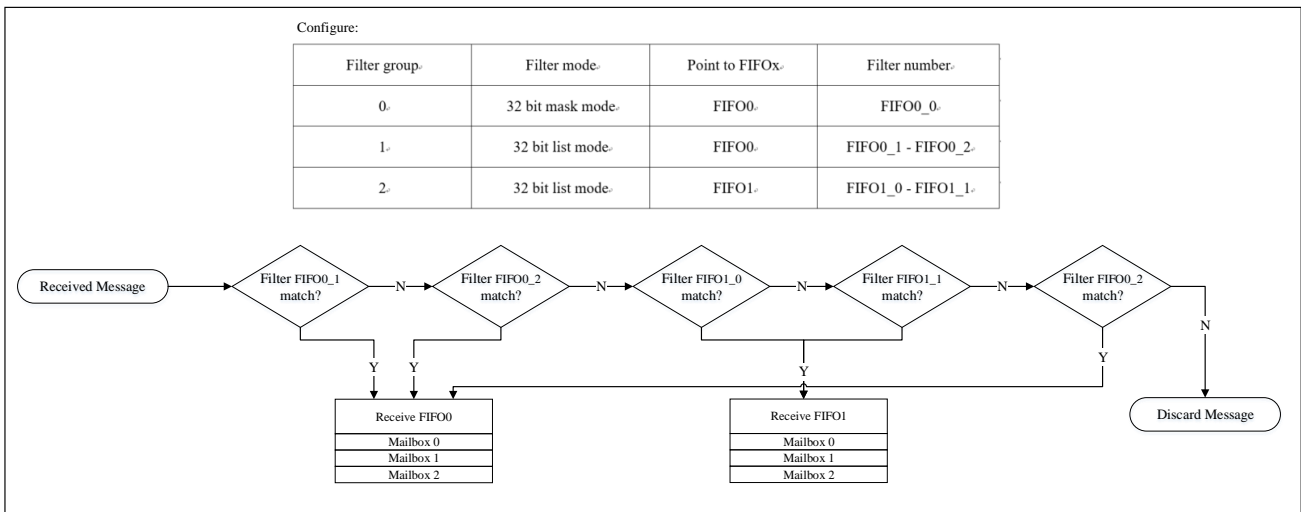

Figure 20-10 illustrates the filter rules of CAN. When receiving a message, its identifier is first compared with the filter configured in identifier list mode. If there is a match, the message will be stored in the associated FIFO, and the serial number of the matched filter will be stored in the filter matching serial number.

If there is no match, the message identifier is then compared with the filter configured in the mask mode. And the hardware will automatically discard the message without software intervention if the message identifier does not match any identifier in the filter.

### 20.4.6 Message storage

A mailbox contains all information related to a message: identifier, data, control, status and time stamp information. Mailbox is the interface between software and hardware to transfer messages.

#### 20.4.6.1 Send mailbox

Message should be written into an empty sending mailbox by software before enable the sending request. You can query the sending status through the CAN\_TSTS register.

Table 20-2 Send mailbox register list

| Offset from the base address of the sending mailbox | Register name |
|---|---------------|
| 0   | CAN_TMIx      |
| 4   | CAN_TMDTx     |
| 8   | CAN_TMDLx     |
| 12  | CAN_TMDHx     |

### 20.4.6.2 Receiving mailbox (FIFO)

CAN\_RMDTx.FMI[7:0] field can store the filter matching serial number and CAN\_RMDTx.MTIM[15:0] field can store the 16-bit timestamp. The software can access the output mailbox of the receiving FIFO to read the received message. Once the software has processed the message, such as reading it out, the software should set the CAN\_RFFx.RFFOM bit to release the corresponding, so as to reserve storage space for later messages.

Table 20-3 Receive mailbox register list

| Offset from the base address of the receiving mailbox | Register name |
|---|---------------|
| 0   | CAN_RMIx      |
| 4   | CAN_RMDTx     |
| 8   | CAN_RMDLx     |
| 12  | CAN_RMDHx     |

### 20.4.7 Bit time characteristic

The bit time characteristic logic monitors the serial CAN bus by sampling, and adjusts its sampling point by synchronizing with the edge of the frame start bit and resynchronizing with the following edge. To avoid programming errors in software, setting the bit time characteristic register (CAN\_BTIM) can only be done when CAN is initialized.

Its operation can be simply understood as dividing each nominal time into three segments: Synchronization segment (SYNC\_SEG), Time period 1(BS1) and Time period 2(BS2).

Usually, it is expected that the change of bits will occur in SYNC\_SEG. Its value is fixed to 1 time unit ( $1 \times t_{CAN}$ ).

BS1 defines the position of the sampling point. It includes PROP\_SEG and PHASE\_SEG1 in CAN standard. Its value can be programmed into 1 to 16 time units, but in order to compensate the forward drift of phase caused by the frequency difference of different nodes in the network, it can also be automatically extended.

In BS2, it defines the location of the sending point. It stands for PHASE\_SEG2 in CAN standard. Its value can be programmed into 1 to 8 time units, but it can also be automatically shortened to compensate for the negative drift of phase.

If a valid transition is detected in BS1 but not in SYNC\_SEG, then the time of BS1 is extended by at most RSJW to delay the sampling point. On the contrary, if a valid transition is detected in BS2 but not in SYNC\_SEG, then the time of BS2 is shortened at most RSJW to advance the sampling point.

In the above description, RSJW(the resynchronization hop width) defines the upper limit of how many time units can

be extended or shortened in each bit. Its value can be programmed into 1 to 4 time units. The effective transition is defined as the first transition from the dominant bit to the recessive bit when CAN itself does not send the recessive bit.

*Note: 1. The time characteristics and resynchronization mechanism of CAN bits are detailed in the ISO11898 standard.*

*2. In order to improve the CAN bit time accuracy, it is not recommended to use HSI as the clock source.*

Figure 20-11 Bit sequence

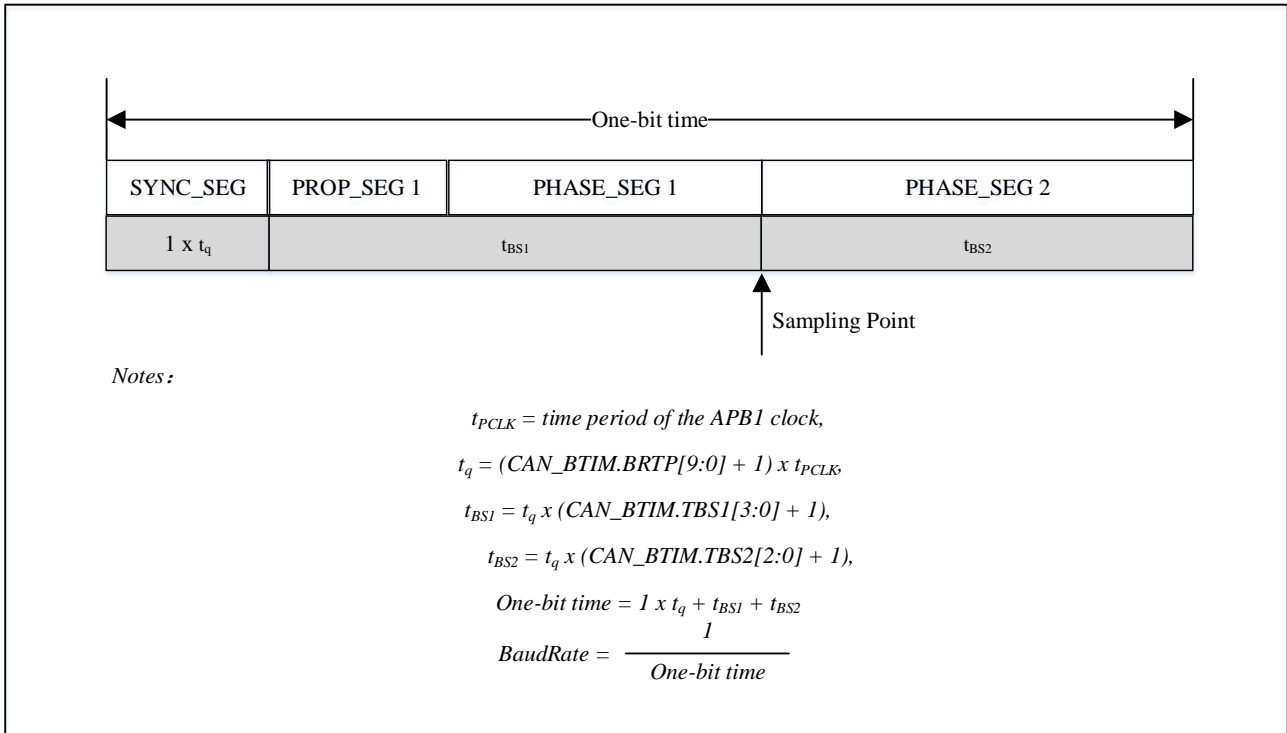
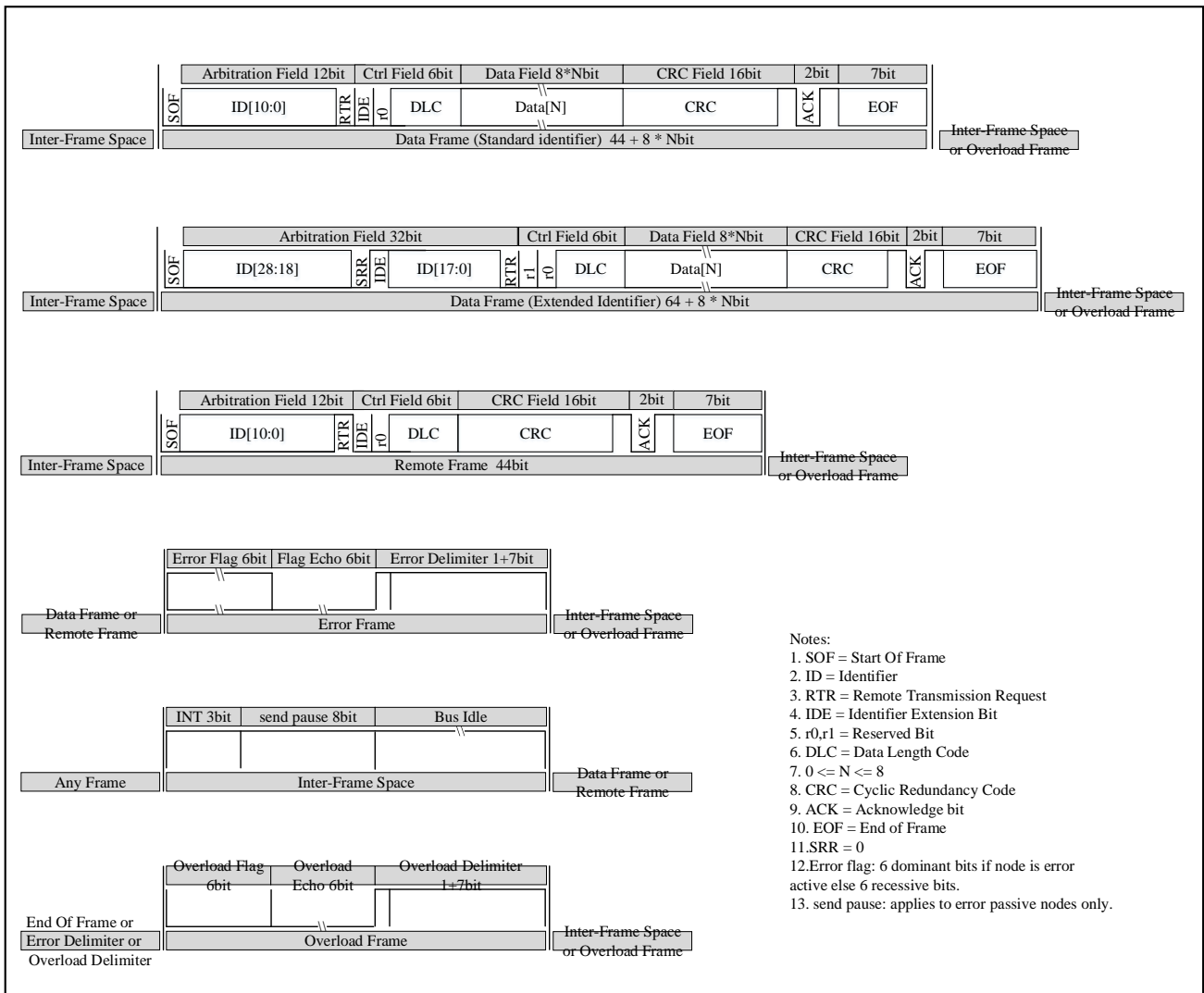
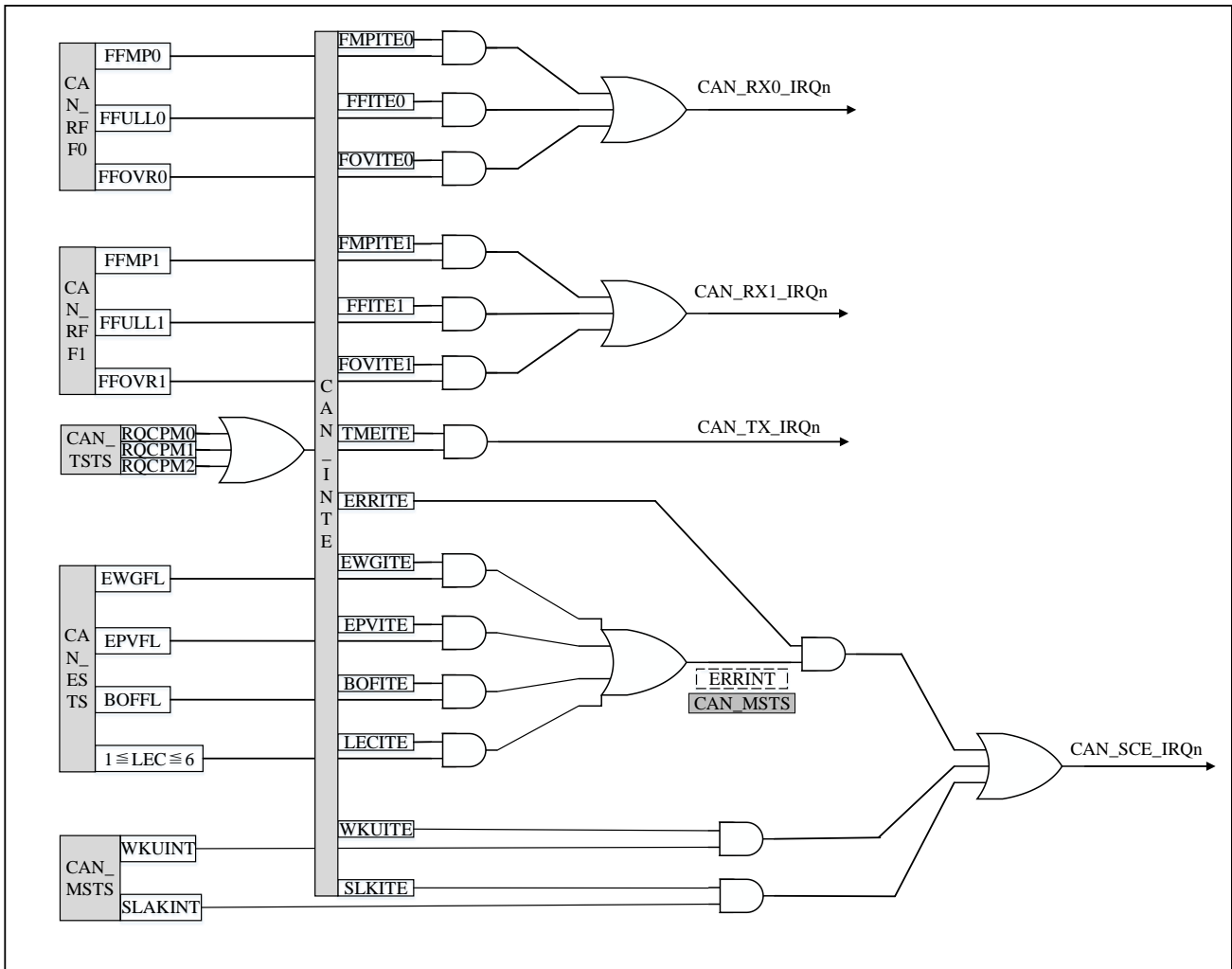

Figure 20-12 Various CAN frames



## 20.5 CAN interrupt

Figure 20-13 Event flag and interrupt generation



CAN has four interrupt vectors. By setting the CAN interrupt enable register (CAN\_INTE), you can individually enable or disable each interrupt source. The following are the events that can generate each interrupt.

- FIFO0 interrupt(CAN\_RX0\_IRQn):

FIFO0 receives a new message, and the CAN\_RFF0.FFMP0 bit is not '00' ;

When FIFO0 becomes full, and the CAN\_RFF0.FFULL0 bit is set;

When FIFO0 overruns, and the CAN\_RFF0.FFOVR0 bit is set.

- FIFO1 interrupt(CAN\_RX1\_IRQn):

FIFO1 receive a new message, and the CAN\_RFF1.FFMP1 bit is not '00'.

When FIFO1 becomes full, and the CAN\_RFF1.FFULL1 bit is set.

When FIFO1 overruns, and the CAN\_RFF1.FFOVR1 bit is set.

- Send interrupts(CAN\_TX\_IRQn):

Send mailbox x becomes empty, and the corresponding CAN\_TSTS.RQCPMx bit is set(x=1/2/3).

■ **Error and status change interrupt(CAN\_SCE\_IRQn):**

CAN enters sleep mode;

Wake-up condition, the start of frame bit (SOF) is monitored on the CAN receiving pin.

Error condition, please refer to the CAN error status register (CAN\_ESTS) for details of the error.

### 20.5.1 Error management

As described in CAN protocol, the error management is completely realized by hardware through sending error counter (CAN\_ESTS.TXEC field) and receiving error counter (CAN\_ESTS.RXEC field). The counter value will increase or decrease according to the error situation. Please refer to CAN standard if you want to know more detailed information about CAN\_ESTS.TXEC and CAN\_ESTS.RXEC management.

Figure 20-14 CAN error state diagram

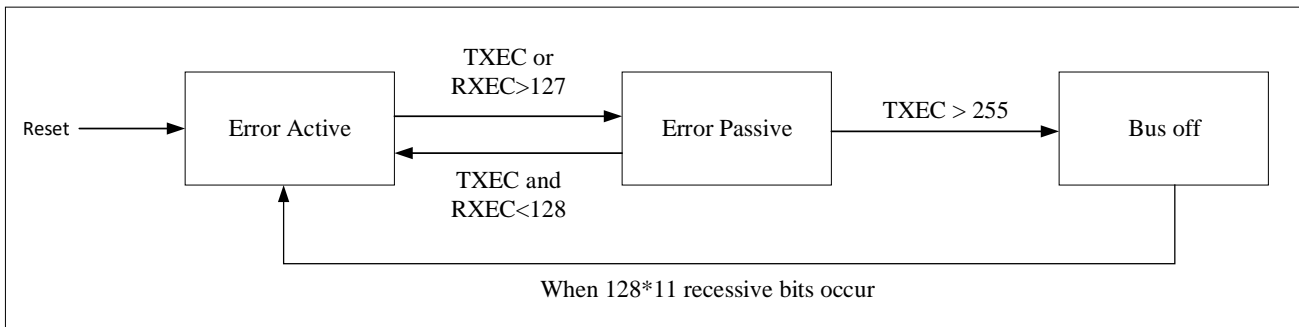

Software can read out the value of the sending/receiving error counter to judge the stability of CAN network, and CAN\_ESTS.LEC[2:0] bits can be read to get the detailed information of the current error status. What's more, by setting the CAN\_INTE register (such as CAN\_INTE.LECITE bit), the software can flexibly control the generation of interrupts when an error is detected.

### 20.5.2 Bus-Off recovery

When TXEC is greater than 255, the CAN\_ESTS.BOFFL bit is set indicating that CAN goes bus-off. at this time, CAN can't receive and send messages.

In normal mode, according to the CAN\_MCTRL.ABOM bit, CAN can automatically or at the request of software, recover from bus-off state, and change to error active state. If the CAN\_MCTRL.ABOM bit is set, the recovery process will be started automatically after it has entered bus-off state. Otherwise, the recovery process will be started after software must request CAN to enter and then exit initialization mode. In both cases, CAN must wait for a recovery process described in CAN standard, that is 128\*11 consecutive recessive bits are detected on CAN RX pin.

In initialization mode, CAN will not monitor the status of CAN RX pin, so the recovery process cannot be completed.

## 20.6 CAN Configuration Flow

This chapter will introduce common configuration procedure of CAN while other details like functions of each mode and register bits are revealed in other part of this manual. CAN configuration flow can divided into several phases. Some of the configurations can be changed anytime as long as prior requirements are satisfied (e.g., filter value).

**■ Preparation Stage:**

1. Configure RCC to enable CAN clock
2. Configure RCC to enable AFIO and GPIO clock
3. Write into GPIO registers to map CAN TX and CAN RX signals to desired GPIO pins.

**■ Basic Configuration Stage:**

1. After reset CAN device starts with Sleep mode.
2. Exit Sleep mode by clearing CAN\_MCTRL.SLPRQ bit.
3. Enter Initialization mode by setting CAN\_MCTRL.INIRQ bit.
4. Wait for CAN\_MSTS.INIAK bit become 1 (enter Initialization mode).
5. Configure bit timing for CAN by writing value to CAN\_BTIM.BSJW, CAN\_BTIM.TBS2, CAN\_BTIM.TBS1 and CAN\_BTIM.BRTP bits. Baud rate of CAN bus is defined by the formula below:

$$BaudRate = \frac{1}{(1 + (TBS1 + 1) + (TBS2 + 1)) * (BRTP * t_{pclk})}$$

6. Configure work mode options for CAN by writing to CAN\_BTIM.SLM (silent) or CAN\_BTIM.LBM in register.
7. Configure CAN behavior(TTCM,ABOM,AWKUM,NART,RFLM,TXFP) through CAN\_MCTRL. Most of the configuration in this register can be changed on the fly but its advised not to do so. Otherwise during few cycles, CAN behavior will become unpredictable.
8. Exit Initialization mode by clearing CAN\_MCTRL.INIRQ bit.
9. Wait for CAN\_MSTS.INIAK bit become 0 (exit Initialization mode).
10. User can use filters to filter the messages they want to receive. To configure filter, user needs to write '1' to CAN\_FMC.FINITM bit to request the filters to enter initialization mode. When filter is in initialization mode, CAN stops reception.
11. Configure each filter for working mode (CAN\_FM1), filter scale (CAN\_FS1) and filter assignment (CAN\_FFA1). User can also change filter value (CAN\_FiRx) during this time. After completing filter configuration, clear CAN\_FMC.FINITM bit to exit initialization for filters.

**■ For transmission:**

1. Enable the necessary transmit related interrupt CAN\_INTE.TMEITE bit.
2. Check status bits of each mailbox in CAN\_TSTS. If any mailbox with TMEIx (x = 0~2) is '1', user can write the message, which is waiting for transmission, to the corresponding mailbox address. CAN\_TMIx.TXRQ(x = 0~2) bit must be written to '1' after this mailbox is programmed.
3. After some time or after waiting for transmit interrupts, come back to check transmit status in CAN\_TSTS. Repeat step 2~3 for new message transmission.

**■ For Reception:**

1. User can also change a filter value (CAN\_FiRx) when the corresponding filter is deactivated. To deactivate certain filter, user needs to write '0' to the corresponding bit in CAN\_FA1 register.
2. Configure reception related interrupts in CAN\_INTE register.

- Once CAN has received message and stored them inside reception FIFO, user needs to read the corresponding FIFO on time and release reception mailbox by writing '1' to RFFOMx in register CAN\_RFFx (x = 0,1).

## 20.7 CAN Register File

These peripheral registers must be operated as words (32 bits).

### 20.7.1 Register Description

#### 20.7.1.1 Register access protection

When a CAN node is working normally, incorrect access/modification of some configuration registers may cause hardware errors in the node and temporarily interfere with the entire CAN network. Therefore, modification of the CAN\_BTIM register is only allowed when the CAN core is in initialization mode.

Only when the send mailbox status bit CAN\_TSTS.TMEM = 1 then the user can modify data to the send mailbox.

#### 20.7.1.2 Control and status registers

By configuring these registers, user can: configure CAN parameters, such as working mode and baud rate; start message sending; handling message reception; interrupt setting; read diagnostic information.

#### 20.7.1.3 Mailbox Register Description

The sending and receiving mailboxes are basically the same except that the receiving mailbox is read-only and contains the CAN\_RMDTx.FMI field. The sending mailbox is writable when it is empty.

*Notes: the corresponding CAN\_TSTS.TMEM bit is set, which means that the sending mailbox is empty.*

There are 3 sending mailboxes and 2 receiving FIFO. Each receiving FIFO has three mailboxes, and only the first received message in the FIFO can be accessed.

Each mailbox contains 4 registers:

FIFO0 contains CAN\_RMI0, CAN\_RMDT0, CAN\_RMDL0, CAN\_RMDH0;

FIFO1 contains CAN\_RMI1, CAN\_RMDT1, CAN\_RMDL1, CAN\_RMDH1;

Send mailbox (x) contains CAN\_TMIx, CAN\_TMDTx, CAN\_TMDLx, CAN\_TMDHx; x = 0,1,2.

#### 20.7.1.4 Filter Register Description

The value of the filter can only be modified when the corresponding filter group is closed or the CAN\_FMC.FINITM bit is set. In addition, only when the whole filter is set to the initialization mode (that is, CAN\_FMC.FINITM=1), the settings of the filter can be modified, that is, the CAN\_FM1, CAN\_FS1 and CAN\_FFA1 registers can be modified.

## 20.7.2 CAN register address overview

Table 20-4 CAN register overview

| Offset | Register    | 31       | 30 | 29 | 28 | 27 | 26 | 25 | 24 | 23 | 22 | 21 | 20 | 19 | 18 | 17   | 16   | 15       | 14 | 13 | 12 | 11 | 10 | 9 | 8 | 7 | 6 | 5    | 4    | 3     | 2    | 1    | 0    |       |       |
|--------|-------------|----------|----|----|----|----|----|----|----|----|----|----|----|----|----|------|------|----------|----|----|----|----|----|---|---|---|---|------|------|-------|------|------|------|-------|-------|
| 000h   | CAN_MCTRL   | Reserved |    |    |    |    |    |    |    |    |    |    |    |    |    | DBGF | MRST | Reserved |    |    |    |    |    |   |   |   |   | TTCM | ABOM | AWKUM | NART | RFLM | TXFP | SLPRQ | INIRQ |
|        | Reset Value |          |    |    |    |    |    |    |    |    |    |    |    |    |    | 1    | 0    |          |    |    |    |    |    |   |   |   |   | 0    | 0    | 0     | 0    | 0    | 0    | 0     | 1     |

| Offset      | Register    | 31                       | 30  | 29        | 28 | 27 | 26        | 25        | 24         | 23 | 22        | 21 | 20 | 19        | 18     | 17          | 16       | 15     | 14       | 13 | 12        | 11     | 10         | 9        | 8      | 7        | 6        | 5       | 4        | 3       | 2          | 1      | 0       |       |
|-------------|-------------|--------------------------|-----|-----------|----|----|-----------|-----------|------------|----|-----------|----|----|-----------|--------|-------------|----------|--------|----------|----|-----------|--------|------------|----------|--------|----------|----------|---------|----------|---------|------------|--------|---------|-------|
| 004h        | CAN_MSTS    | Reserved                 |     |           |    |    |           |           |            |    |           |    |    |           |        |             |          |        |          |    |           | RXS    | LSMP       | RXMD     | TXMD   | Reserved |          |         | SLAKINT  | WKUJINT | ERRINT     | SLPAK  | INI/AK  |       |
|             | Reset Value |                          |     |           |    |    |           |           |            |    |           |    |    |           |        |             |          |        |          |    |           | 1      | 1          | 0        | 0      |          |          |         | 0        | 0       | 0          | 1      | 0       |       |
| 008h        | CAN_TSTS    | LOWM[2:0]                |     | TMEM[2:0] |    |    | CODE[1:0] |           | ABRQM2     |    | Reserved  |    |    | TERRM2    | ALSTM2 | TXOKM2      | RQCPM2   | ABRQM1 | Reserved |    |           | TERRM1 | ALSTM1     | TXOKM1   | RQCPM1 | ABRQM0   | Reserved |         |          | TERRM0  | ALSTM0     | TXOKM0 | RQCPM0  |       |
|             | Reset Value | 0                        | 0   | 0         | 1  | 1  | 1         | 0         | 0          | 0  |           |    |    | 0         | 0      | 0           | 0        | 0      |          |    |           | 0      | 0          | 0        | 0      | 0        |          |         |          | 0       | 0          | 0      | 0       |       |
| 00Ch        | CAN_RFF0    | Reserved                 |     |           |    |    |           |           |            |    |           |    |    |           |        |             |          |        |          |    |           |        |            |          |        | RFOM0    | FFOV0    | FFULL0  | Reserved |         | FFMP0[1:0] |        |         |       |
|             | Reset Value |                          |     |           |    |    |           |           |            |    |           |    |    |           |        |             |          |        |          |    |           |        |            |          |        | 0        | 0        | 0       |          |         | 0          | 0      |         |       |
| 010h        | CAN_RFF1    | Reserved                 |     |           |    |    |           |           |            |    |           |    |    |           |        |             |          |        |          |    |           |        |            |          |        | RFOM1    | FFOV1    | FFULL1  | Reserved |         | FFMP1[1:0] |        |         |       |
|             | Reset Value |                          |     |           |    |    |           |           |            |    |           |    |    |           |        |             |          |        |          |    |           |        |            |          |        | 0        | 0        | 0       |          |         | 0          | 0      |         |       |
| 014h        | CAN_INTE    | Reserved                 |     |           |    |    |           |           |            |    |           |    |    |           |        | SLKITE      | WKUITE   | ERRITE | Reserved |    |           | LECITE | BOFITE     | EPVITE   | EWGITE | Reserved |          | FOVITE1 | FFITE1   | EMPITE1 | FOVITE0    | FFITE0 | EMPITE0 | TMETE |
|             | Reset Value |                          |     |           |    |    |           |           |            |    |           |    |    |           |        | 0           | 0        | 0      |          |    |           | 0      | 0          | 0        | 0      |          |          | 0       | 0        | 0       | 0          | 0      | 0       | 0     |
| 018h        | CAN_ESTS    | RXEC[7:0]                |     |           |    |    |           |           | TXEC[7:0]  |    |           |    |    |           |        | Reserved    |          |        |          |    |           |        | LEC[2:0]   |          |        | Reserved |          | BOFEL   | EPVFL    | EWGFL   |            |        |         |       |
|             | Reset Value | 0                        | 0   | 0         | 0  | 0  | 0         | 0         | 0          | 0  | 0         | 0  | 0  | 0         | 0      | 0           | 0        | 0      | 0        | 0  | 0         | 0      | 0          | 0        | 0      | 0        | 0        | 0       | 0        | 0       | 0          | 0      | 0       |       |
| 01Ch        | CAN_BTIM    | SLM                      | LBM | Reserved  |    |    |           | RSJW[1:0] | Reserved   |    | TBS2[2:0] |    |    | TBS1[3:0] |        |             | Reserved |        |          |    | BRTP[9:0] |        |            |          |        |          |          |         |          |         |            |        |         |       |
|             | Reset Value | 0                        | 0   |           |    |    |           | 0         | 1          |    |           | 0  | 1  | 0         | 0      | 0           | 1        | 1      |          |    |           |        | 0          | 0        | 0      | 0        | 0        | 0       | 0        | 0       | 0          | 0      | 0       | 0     |
| 020h - 17Fh | Reserved    |                          |     |           |    |    |           |           |            |    |           |    |    |           |        |             |          |        |          |    |           |        |            |          |        |          |          |         |          |         |            |        |         |       |
| 180h        | CAN_TMI0    | STDID[10:0]/EXTID[28:18] |     |           |    |    |           |           |            |    |           |    |    |           |        | EXTID[17:0] |          |        |          |    |           |        |            |          |        |          |          |         |          | IDE     | RTRQ       | TXRQ   |         |       |
|             | Reset Value | x                        | x   | x         | x  | x  | x         | x         | x          | x  | x         | x  | x  | x         | x      | x           | x        | x      | x        | x  | x         | x      | x          | x        | x      | x        | x        | x       | x        | x       | x          | x      | 0       |       |
| 184h        | CAN_TMDT0   | MTIM[15:0]               |     |           |    |    |           |           |            |    |           |    |    |           |        | Reserved    |          |        |          |    |           |        | TGT        | Reserved |        |          | DLC[3:0] |         |          |         |            |        |         |       |
|             | Reset Value | x                        | x   | x         | x  | x  | x         | x         | x          | x  | x         | x  | x  | x         | x      | x           | x        | x      | x        | x  | x         | x      | x          | x        | x      | x        | x        | x       | x        | x       | x          | x      | x       |       |
| 188h        | CAN_TMDL0   | DATA3[7:0]               |     |           |    |    |           |           | DATA2[7:0] |    |           |    |    |           |        | DATA1[7:0]  |          |        |          |    |           |        | DATA0[7:0] |          |        |          |          |         |          |         |            |        |         |       |
|             | Reset Value | x                        | x   | x         | x  | x  | x         | x         | x          | x  | x         | x  | x  | x         | x      | x           | x        | x      | x        | x  | x         | x      | x          | x        | x      | x        | x        | x       | x        | x       | x          | x      | x       | x     |
| 18Ch        | CAN_TMDH0   | DATA7[7:0]               |     |           |    |    |           |           | DATA6[7:0] |    |           |    |    |           |        | DATA5[7:0]  |          |        |          |    |           |        | DATA4[7:0] |          |        |          |          |         |          |         |            |        |         |       |
|             | Reset Value | x                        | x   | x         | x  | x  | x         | x         | x          | x  | x         | x  | x  | x         | x      | x           | x        | x      | x        | x  | x         | x      | x          | x        | x      | x        | x        | x       | x        | x       | x          | x      | x       | x     |
| 190h        | CAN_TMI1    | STDID[10:0]/EXTID[28:18] |     |           |    |    |           |           |            |    |           |    |    |           |        | EXTID[17:0] |          |        |          |    |           |        |            |          |        |          |          |         |          | IDE     | RTRQ       | TXRQ   |         |       |
|             | Reset Value | x                        | x   | x         | x  | x  | x         | x         | x          | x  | x         | x  | x  | x         | x      | x           | x        | x      | x        | x  | x         | x      | x          | x        | x      | x        | x        | x       | x        | x       | x          | x      | 0       |       |
| 194h        | CAN_TMDT1   | MTIM[15:0]               |     |           |    |    |           |           |            |    |           |    |    |           |        | Reserved    |          |        |          |    |           |        | TGT        | Reserved |        |          | DLC[3:0] |         |          |         |            |        |         |       |
|             | Reset Value | x                        | x   | x         | x  | x  | x         | x         | x          | x  | x         | x  | x  | x         | x      | x           | x        | x      | x        | x  | x         | x      | x          | x        | x      | x        | x        | x       | x        | x       | x          | x      | x       |       |
| 198h        | CAN_TMDL1   | DATA3[7:0]               |     |           |    |    |           |           | DATA2[7:0] |    |           |    |    |           |        | DATA1[7:0]  |          |        |          |    |           |        | DATA0[7:0] |          |        |          |          |         |          |         |            |        |         |       |
|             | Reset Value | x                        | x   | x         | x  | x  | x         | x         | x          | x  | x         | x  | x  | x         | x      | x           | x        | x      | x        | x  | x         | x      | x          | x        | x      | x        | x        | x       | x        | x       | x          | x      | x       | x     |

| Offset      | Register    | 31                       | 30 | 29 | 28 | 27 | 26 | 25 | 24         | 23 | 22 | 21          | 20 | 19 | 18       | 17         | 16 | 15 | 14       | 13       | 12 | 11 | 10         | 9        | 8 | 7 | 6 | 5   | 4    | 3        | 2 | 1      | 0 |
|-------------|-------------|--------------------------|----|----|----|----|----|----|------------|----|----|-------------|----|----|----------|------------|----|----|----------|----------|----|----|------------|----------|---|---|---|-----|------|----------|---|--------|---|
| 19Ch        | CAN_TMDH1   | DATA7[7:0]               |    |    |    |    |    |    | DATA6[7:0] |    |    |             |    |    |          | DATA5[7:0] |    |    |          |          |    |    | DATA4[7:0] |          |   |   |   |     |      |          |   |        |   |
|             | Reset Value | x                        | x  | x  | x  | x  | x  | x  | x          | x  | x  | x           | x  | x  | x        | x          | x  | x  | x        | x        | x  | x  | x          | x        | x | x | x | x   | x    | x        | x | x      | x |
| 1A0h        | CAN_TMI2    | STDID[10:0]/EXTID[28:18] |    |    |    |    |    |    |            |    |    | EXTID[17:0] |    |    |          |            |    |    |          |          |    |    |            |          |   |   |   | IDE | RTRQ | TXRQ     |   |        |   |
|             | Reset Value | x                        | x  | x  | x  | x  | x  | x  | x          | x  | x  | x           | x  | x  | x        | x          | x  | x  | x        | x        | x  | x  | x          | x        | x | x | x | x   | x    | x        | x | x      | 0 |
| 1A4h        | CAN_TMDT2   | MTIM[15:0]               |    |    |    |    |    |    |            |    |    |             |    |    | Reserved |            |    |    | TGT      | Reserved |    |    |            | DLC[3:0] |   |   |   |     |      |          |   |        |   |
|             | Reset Value | x                        | x  | x  | x  | x  | x  | x  | x          | x  | x  | x           | x  | x  | x        | x          | x  | x  | x        | x        | x  | x  | x          | x        | x | x | x | x   | x    | x        | x | x      |   |
| 1A8h        | CAN_TMDL2   | DATA3[7:0]               |    |    |    |    |    |    | DATA2[7:0] |    |    |             |    |    |          | DATA1[7:0] |    |    |          |          |    |    | DATA0[7:0] |          |   |   |   |     |      |          |   |        |   |
|             | Reset Value | x                        | x  | x  | x  | x  | x  | x  | x          | x  | x  | x           | x  | x  | x        | x          | x  | x  | x        | x        | x  | x  | x          | x        | x | x | x | x   | x    | x        | x | x      |   |
| 1ACh        | CAN_TMDH2   | DATA7[7:0]               |    |    |    |    |    |    | DATA6[7:0] |    |    |             |    |    |          | DATA5[7:0] |    |    |          |          |    |    | DATA4[7:0] |          |   |   |   |     |      |          |   |        |   |
|             | Reset Value | x                        | x  | x  | x  | x  | x  | x  | x          | x  | x  | x           | x  | x  | x        | x          | x  | x  | x        | x        | x  | x  | x          | x        | x | x | x | x   | x    | x        | x | x      |   |
| 1B0h        | CAN_RMI0    | STDID[10:0]/EXTID[28:18] |    |    |    |    |    |    |            |    |    | EXTID[17:0] |    |    |          |            |    |    |          |          |    |    |            |          |   |   |   | IDE | RTRQ | Reserved |   |        |   |
|             | Reset Value | x                        | x  | x  | x  | x  | x  | x  | x          | x  | x  | x           | x  | x  | x        | x          | x  | x  | x        | x        | x  | x  | x          | x        | x | x | x | x   | x    | x        | x | x      |   |
| 1B4h        | CAN_RMDT0   | MTIM[15:0]               |    |    |    |    |    |    |            |    |    |             |    |    | FMI[7:0] |            |    |    | Reserved |          |    |    | DLC[3:0]   |          |   |   |   |     |      |          |   |        |   |
|             | Reset Value | x                        | x  | x  | x  | x  | x  | x  | x          | x  | x  | x           | x  | x  | x        | x          | x  | x  | x        | x        | x  | x  | x          | x        | x | x | x | x   | x    | x        | x |        |   |
| 1B8h        | CAN_RMDL0   | DATA3[7:0]               |    |    |    |    |    |    | DATA2[7:0] |    |    |             |    |    |          | DATA1[7:0] |    |    |          |          |    |    | DATA0[7:0] |          |   |   |   |     |      |          |   |        |   |
|             | Reset Value | x                        | x  | x  | x  | x  | x  | x  | x          | x  | x  | x           | x  | x  | x        | x          | x  | x  | x        | x        | x  | x  | x          | x        | x | x | x | x   | x    | x        | x | x      |   |
| 1BCh        | CAN_RMDH0   | DATA7[7:0]               |    |    |    |    |    |    | DATA6[7:0] |    |    |             |    |    |          | DATA5[7:0] |    |    |          |          |    |    | DATA4[7:0] |          |   |   |   |     |      |          |   |        |   |
|             | Reset Value | x                        | x  | x  | x  | x  | x  | x  | x          | x  | x  | x           | x  | x  | x        | x          | x  | x  | x        | x        | x  | x  | x          | x        | x | x | x | x   | x    | x        | x | x      |   |
| 1C0h        | CAN_RMI1    | STDID[10:0]/EXTID[28:18] |    |    |    |    |    |    |            |    |    | EXTID[17:0] |    |    |          |            |    |    |          |          |    |    |            |          |   |   |   | IDE | RTRQ | Reserved |   |        |   |
|             | Reset Value | x                        | x  | x  | x  | x  | x  | x  | x          | x  | x  | x           | x  | x  | x        | x          | x  | x  | x        | x        | x  | x  | x          | x        | x | x | x | x   | x    | x        | x | x      |   |
| 1C4h        | CAN_RMDT1   | MTIM[15:0]               |    |    |    |    |    |    |            |    |    |             |    |    | FMI[7:0] |            |    |    | Reserved |          |    |    | DLC[3:0]   |          |   |   |   |     |      |          |   |        |   |
|             | Reset Value | x                        | x  | x  | x  | x  | x  | x  | x          | x  | x  | x           | x  | x  | x        | x          | x  | x  | x        | x        | x  | x  | x          | x        | x | x | x | x   | x    | x        | x |        |   |
| 1C8h        | CAN_RMDL1   | DATA3[7:0]               |    |    |    |    |    |    | DATA2[7:0] |    |    |             |    |    |          | DATA1[7:0] |    |    |          |          |    |    | DATA0[7:0] |          |   |   |   |     |      |          |   |        |   |
|             | Reset Value | x                        | x  | x  | x  | x  | x  | x  | x          | x  | x  | x           | x  | x  | x        | x          | x  | x  | x        | x        | x  | x  | x          | x        | x | x | x | x   | x    | x        | x | x      |   |
| 1CCh        | CAN_RMDH1   | DATA7[7:0]               |    |    |    |    |    |    | DATA6[7:0] |    |    |             |    |    |          | DATA5[7:0] |    |    |          |          |    |    | DATA4[7:0] |          |   |   |   |     |      |          |   |        |   |
|             | Reset Value | x                        | x  | x  | x  | x  | x  | x  | x          | x  | x  | x           | x  | x  | x        | x          | x  | x  | x        | x        | x  | x  | x          | x        | x | x | x | x   | x    | x        | x | x      |   |
| 1D0h - 1FFh | Reserved    |                          |    |    |    |    |    |    |            |    |    |             |    |    |          |            |    |    |          |          |    |    |            |          |   |   |   |     |      |          |   |        |   |
| 200h        | CAN_FMC     | Reserved                 |    |    |    |    |    |    |            |    |    |             |    |    |          |            |    |    |          |          |    |    |            |          |   |   |   |     |      |          |   | FINITM |   |
|             | Reset Value |                          |    |    |    |    |    |    |            |    |    |             |    |    |          |            |    |    |          |          |    |    |            |          |   |   |   |     |      |          |   | 1      |   |





| Bit Field | Name  | Description  |
|-----------|-------|--|
|           |       | <p>This bit determines whether CAN is awakened by hardware or software when it is in sleep mode.</p> <p>0: The sleep mode is awakened by the software by clearing the CAN_MCTRL.SLPRQ bit;</p> <p>1: Sleep mode is automatically awakened by hardware by detecting CAN messages. At the same time of wake-up, the hardware automatically clears the CAN_MSTS.SLPRQ and CAN_MSTS.SLPAK bits.</p>  |
| 4         | NART  | <p>No automatic retransmission</p> <p>0: According to the CAN standard, when the CAN hardware fails to send a message, it will automatically retransmit it until it is successfully sent;</p> <p>1: CAN message is only sent once, regardless of the sending result (success, error or arbitration loss).</p>  |
| 3         | RFLM  | <p>Receive FIFO locked mode.</p> <p>0: the FIFO is not locked when receiving overflows, and when the message of the receiving FIFO is not read out, the next received message will overwrite the last message;</p> <p>1: FIFO is locked when receiving overflow. When the message of receiving FIFO is not read out, the next received message will be discarded.</p>  |
| 2         | TXFP  | <p>Transmit FIFO priority</p> <p>When there are multiple messages waiting to be sent at the same time, this bit determines the sending order of these messages.</p> <p>0: Priority is determined by the identifier of the message;</p> <p>1: Priority is determined by the order in which requests are sent.</p>   |
| 1         | SLPRQ | <p>Sleep mode request</p> <p>The software can request the CAN to enter the sleep mode by setting this bit, and once the current CAN activity (sending or receiving messages) ends, the CAN will enter the sleep mode.</p> <p>Clear by software to make CAN exit sleep mode.</p> <p>When the CAN_MCTRL.AWKUM bit is set and the SOF bit is detected in the CAN Rx signal, the hardware clears this bit.</p> <p>This bit is set after reset, that is, CAN is in sleep mode after reset.</p>  |
| 0         | INIRQ | <p>Initialization request</p> <p>clear this bit by software can make CAN exit from initialization mode: when CAN leaves Initialization mode and entering normal mode, it needs to detect 11 consecutive recessive bits at the receiving pin, CAN will be synchronized and ready for receiving and sending data. To this end, the hardware correspondingly the CAN_MSTS.INIAK bit is cleared.</p> <p>Setting this bit by software enables CAN to enter initialization mode from normal operation mode: once the current CAN activity (sending or receiving) is over, the hardware sets the CAN_MSTS.INIAK bit and CAN enters initialization mode.</p> |

### 20.7.3.2 CAN master status register (CAN\_MSTS)

Address offset: 0x04

Reset value: 0x0000c02

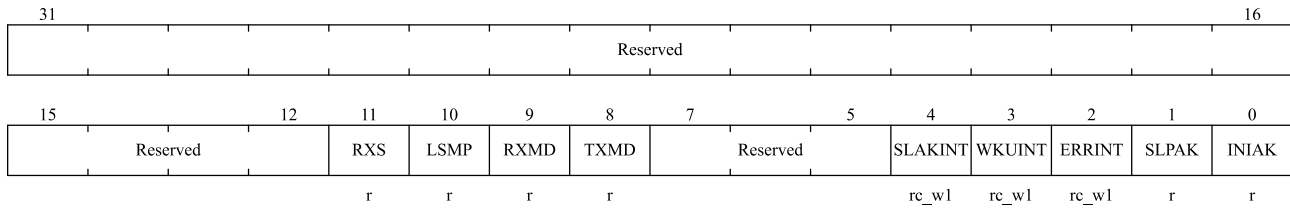

| Bit Field | Name     | Description  |
|-----------|----------|--|
| 31:12     | Reserved | Reserved, the reset value must be maintained.  |
| 11        | RXS      | CAN Rx signal<br>This bit reflects the actual level of the CAN receive pin (CAN_RX).   |
| 10        | LSMP     | Last sample point<br>The last sampled value of the CAN receive pin (corresponding to the value of the current receive bit).  |
| 9         | RXMD     | Receive mode<br>if this bit equals to 1 indicates CAN is currently the receiver.   |
| 8         | TXMD     | Transmit mode<br>if this bit equals to 1 indicates CAN is currently the transmitter.   |
| 7:5       | Reserved | Reserved, the reset value must be maintained.  |
| 4         | SLAKINT  | Sleep acknowledge interrupt<br>When CAN_INTE.SLKITE=1, once CAN enters sleep mode, hardware will set this bit, and then the corresponding interrupt will be triggered. When this bit is set, if the CAN_INTE.SLKITE bit is set, a state change interrupt will be generated.<br>Software can clear this bit, and hardware also clears this bit when CAN_MSTS.SLPAK bit is cleared.<br><i>Notes: When CAN_INTE.SLKITE=0, this bit should not be queried, but the CAN_MSTS.SLPAK bit should be queried to know the sleep state.</i> |
| 3         | WKUINT   | Wakeup interrupt<br>When CAN is in sleep state, once the start of frame bit (SOF) is detected, the hardware will set this bit; And if the CAN_INTE.WKUIITE bit is set, a state change interrupt is generated.<br>This bit is cleared by software.  |
| 2         | ERRINT   | Error interrupt<br>When an error is detected, a bit of the CAN_ESTS register will be set, and if the corresponding interrupt enable bit of the CAN_INTE register is also set, the hardware will set this bit; If the CAN_INTE.ERRITE bit is set, a state change interrupt is generated. This bit is cleared by software.   |
| 1         | SLPAK    | Sleep acknowledge<br>This bit is set by hardware, indicating that the software CAN module is in sleep mode. This bit is the confirmation of the software request to enter sleep mode ( the CAN_MCTRL.SLPRQ bit is set).<br>Hardware clears this bit when CAN exits sleep mode (CAN leaves Sleep mode   |

| Bit Field | Name  | Description  |
|-----------|-------|--|
|           |       | and entering normal mode,it needs to be synchronized with CAN bus).<br>Synchronization with CAN bus here means that the hardware needs to detect 11 consecutive recessive bits on the RX pin of CAN.<br><i>Notes: clearing CAN_MCTRL.SLPRQ bit by software or hardware will start the process of exiting sleep mode. See the description of CAN_MCTRL.AWKUM bit for details of clearing CAN_MCTRL.SLPRQ bit.</i>   |
| 0         | INIAK | Initialization acknowledge<br>This bit is set by hardware, indicating that the software CAN module is in initialization mode. This bit is the confirmation of the software request to enter the initialization mode (the CAN_MCTRL.INIRQ bit is set).<br>Hardware clears this bit when CAN exits initialization mode (CAN leaves Initialization mode and entering normal mode,it needs to be synchronized with CAN bus). Synchronization with CAN bus here means that the hardware needs to detect 11 consecutive recessive bits on the RX pin of CAN. |

### 20.7.3.3 CAN transmit status register (CAN\_TSTS)

Address offset: 0x08

Reset value: 0x1C00 0000

|        |          |       |        |        |        |        |        |          |          |        |        |        |        |        |   |
|--------|----------|-------|--------|--------|--------|--------|--------|----------|----------|--------|--------|--------|--------|--------|---|
| 31     | 30       | 29    | 28     | 27     | 26     | 25     | 24     | 23       | 22       | 20     | 19     | 18     | 17     | 16     |   |
| LOWM2  | LOWM1    | LOWM0 | TMEM2  | TMEM1  | TMEM0  | CODE   |        | ABRQM2   | Reserved |        | TERRM2 | ALSTM2 | TXOKM2 | RQCPM2 |   |
| r      | r        | r     | r      | r      | r      | r      |        | rs       |          |        | rc_w1  | rc_w1  | rc_w1  | rc_w1  |   |
| 15     | 14       |       | 12     | 11     | 10     | 9      |        | 8        | 7        | 6      | 4      | 3      | 2      | 1      | 0 |
| ABRQM1 | Reserved |       | TERRM1 | ALSTM1 | TXOKM1 | RQCPM1 | ABRQM0 | Reserved |          | TERRM0 | ALSTM0 | TXOKM0 | RQCPM0 |        |   |
| rs     |          |       | rc_w1  | rc_w1  | rc_w1  | rc_w1  | rs     |          |          | rc_w1  | rc_w1  | rc_w1  | rc_w1  |        |   |

| Bit Field | Name      | Description   |
|-----------|-----------|---|
| 31        | LOWM2     | Lowest priority flag for mailbox 2<br>When multiple mailboxes are waiting to send messages, and the priority of mailbox 2 is the lowest, hardware sets this bit.  |
| 30        | LOWM1     | Lowest priority flag for mailbox 1<br>When multiple mailboxes are waiting to send messages, and the priority of mailbox 1 is the lowest, hardware sets this bit.  |
| 29        | LOWM0     | Lowest priority flag for mailbox 0<br>When multiple mailboxes are waiting to send messages, and the priority of mailbox 0 is the lowest, hardware sets this bit.<br><i>Notes: If there is only one mailbox waiting, CAN_TSTS.LOWM[2:0] is cleared</i> |
| 28        | TMEM2     | Transmit mailbox 2 empty<br>When there is no message waiting to be sent in mailbox 2, hardware sets this bit.   |
| 27        | TMEM1     | Transmit mailbox 1 empty<br>When there is no message waiting to be sent in mailbox 1, hardware sets this bit.   |
| 26        | TMEM0     | Transmit mailbox 0 empty<br>When there is no message waiting to be sent in mailbox 0, hardware sets this bit .  |
| 25:24     | CODE[1:0] | Mailbox code  |

| Bit Field | Name     | Description  |
|-----------|----------|--|
|           |          | <p>When at least one sending mailbox is empty, these two bits represent the next empty sending mailbox number.</p> <p>When all sending mailboxes are empty, these two bits represent the sending mailbox number with the lowest priority.</p>  |
| 23        | ABRQM2   | <p>Abort request for mailbox 2</p> <p>Set this bit, software can stop the sending request of mailbox 2, and hardware clears this bit when the sending message of mailbox 2 is idle. If there is no message waiting to be sent in mailbox 2, it will have no effect to set this bit.</p>  |
| 22:20     | Reserved | Reserved, hardware force is 0.   |
| 19        | TERRM2   | <p>Transmission error of mailbox 2 failed.</p> <p>When the mailbox 2 fails to send due to an error, set this bit.</p>  |
| 18        | ALSTM2   | <p>Arbitration lost for mailbox 2</p> <p>When the mailbox 2 fails to send due to the loss of arbitration, set this bit.</p>  |
| 17        | TXOKM2   | <p>Transmission OK of mailbox 2</p> <p>The hardware updates this bit after each sending attempt of mailbox 2:</p> <p>0: The last sending attempt is not yet successful;</p> <p>1: The last sending attempt was successful.</p> <p>When the sending request of mailbox 2 is successfully completed, hardware sets this bit. See Figure 20-7.</p>  |
| 16        | RQCPM2   | <p>Request completed mailbox 2</p> <p>When the last request (send or abort) for mailbox 2 is completed, the hardware will set this bit.</p> <p>Writing '1' to this bit by software can clear it; When the hardware receives the send request, it can also clear this bit (the CAN_TMI2.TXRQ bit is set).</p> <p>When this bit is cleared, other sending status bits (CAN_TSTS.TXOKM2, CAN_TSTS.ALSTM2 and CAN_TSTS.TERRM2 bits) of mailbox 2 are also cleared.</p> |
| 15        | ABRQM1   | <p>Abort request for mailbox 1</p> <p>Set this bit, the software can stop the sending request of mailbox 1, and the hardware clears this bit when the sending message of mailbox 1 is idle. If there is no message waiting to be sent in mailbox 1, it will have no effect to set this bit.</p>  |
| 14:12     | Reserved | Reserved, the reset value must be maintained.  |
| 11        | TERRM1   | <p>Transmission error of mailbox 1</p> <p>When the mailbox 1 fails to send due to an error, set this bit.</p>  |
| 10        | ALSTM1   | <p>Arbitration lost for mailbox 1</p> <p>When the mailbox 1 fails to send due to the loss of arbitration, set this bit</p>   |
| 9         | TXOKM1   | <p>Transmission OK of mailbox 1</p> <p>The hardware updates this bit after each sending attempt of mailbox 1:</p> <p>0: The last sending attempt is not yet successful;</p> <p>1: The last sending attempt was successful.</p> <p>When the sending request of mailbox 1 is successfully completed, the hardware sets this bit. See Figure 20-7.</p>  |
| 8         | RQCPM1   | Request completed mailbox 1  |

| Bit Field | Name     | Description  |
|-----------|----------|--|
|           |          | When the last request (send or abort) for mailbox 1 is completed, the hardware sets this bit.<br>Writing '1' to this bit by software can clear it; When the hardware receives the send request, it can also clear this bit (the CAN_TMI1.TXRQ bit is set).<br>When this bit is cleared, other sending status bits (CAN_TSTS.TXOKM1, CAN_TSTS.ALSTM1 and CAN_TSTS.TERRM1 bits) of mailbox 1 are also cleared.                                 |
| 7         | ABRQM0   | Abort request for mailbox 0<br>The software can stop the sending request of mailbox 0 by setting this bit, and the hardware clears this bit when the sending message of mailbox 0 is idle. If there is no message waiting to be sent in mailbox 0, it will have no effect to set this bit.   |
| 6:4       | Reserved | Reserved, the reset value must be maintained.  |
| 3         | TERRM0   | Transmission error of mailbox 0<br>When the mailbox 0 fails to send due to an error, set this bit.   |
| 2         | ALSTM0   | Arbitration lost for mailbox 0<br>When the mailbox 0 fails to send due to the loss of arbitration, set this bit  |
| 1         | TXOKM0   | Transmission OK of mailbox 0<br>The hardware updates this bit after each attempt to send mailbox 0:<br>0: The last send attempt is not yet successful;<br>1: The last sending attempt was successful.<br>When the sending request of mailbox 0 is successfully completed, the hardware sets this bit. See Figure 20-7.   |
| 0         | RQCPM0   | Request completed mailbox 0<br>When the last request (send or abort) for mailbox 0 was completed, the hardware sets this bit.<br>Writing '1' to this bit by software can clear it; When the hardware receives the send request, it can also clear this bit (the CAN_TMI0.TXRQ bit is set).<br>When this bit is cleared, other sending status bits (CAN_TSTS.TXOKM0, CAN_TSTS.ALSTM0 and CAN_TSTS.TERRM0 bits) of mailbox 0 are also cleared. |

### 20.7.3.4 CAN receive FIFO 0 register (CAN\_RFF0)

Address offset: 0x0c

Reset value: 0x0000 0000

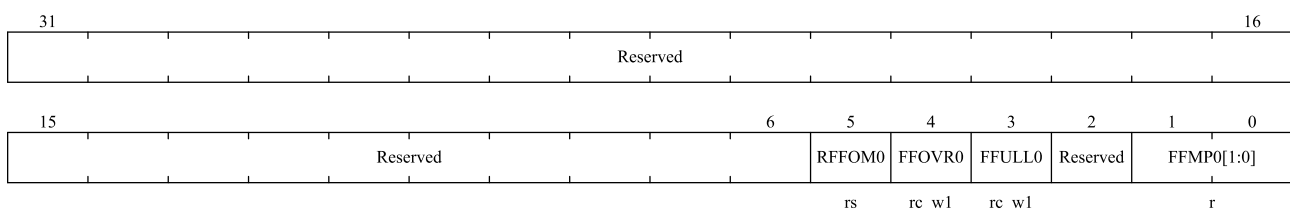

| Bit Field | Name     | Description                                   |
|-----------|----------|---|
| 31:6      | Reserved | Reserved, the reset value must be maintained. |

| Bit Field | Name       | Description  |
|-----------|------------|--|
| 5         | RFFOM0     | Release FIFO 0 output mailbox.<br>The software releases the output mailbox of the receive FIFO by setting this bit. If the receiving FIFO is empty, it will have no effect on setting this bit, that is, it will be meaningful to set this bit only when there is a message in the FIFO. If there are more than two messages in FIFO, because of the characteristics of FIFO, the software needs to release the output mailbox to access the second message.<br>When the output mailbox is released, the hardware clears this bit. |
| 4         | FFOVR0     | FIFO 0 overrun<br>When FIFO 0 is full, a new message is received and the message meets the filtering conditions, the hardware sets this bit. This bit is cleared by software.  |
| 3         | FFULL0     | FIFO 0 full<br>When there are 3 messages in FIFO 0, the hardware sets this bit'. This bit is cleared by software.  |
| 2         | Reserved   | Reserved, the reset value must be maintained.  |
| 1:0       | FFMP0[1:0] | FIFO 0 message pending<br>Number of FIFO messages 0 These two bits reflect the number of messages currently stored in the receiving FIFO 0. Every time a new message is stored in the receiving FIFO 0, the hardware adds 1 to the CAN_RFF0.FFMP0.<br>Every time the software writes '1' to the CAN_RFF0.RFFOM0 bit to release the output mailbox, CAN_RFF0.FFMP0 is decremented by 1 until it is 0.   |

### 20.7.3.5 CAN receive FIFO 1 register (CAN\_RFF1)

Address offset: 0x10

Reset value: 0x0000 0000

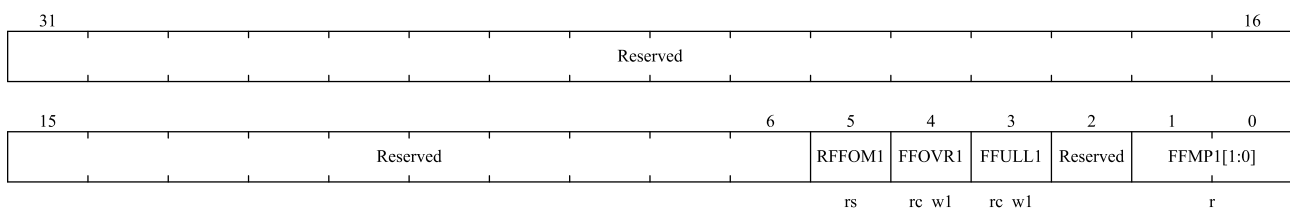

| Bit Field | Name     | Description  |
|-----------|----------|--|
| 31:6      | Reserved | Reserved, the reset value must be maintained.  |
| 5         | RFFOM1   | Release FIFO 1 output mailbox.<br>The software releases the output mailbox of the receive FIFO by setting this bit. If the receiving FIFO is empty, it will have no effect on setting this bit, that is, it will be meaningful to set this bit only when there is a message in the FIFO. If there are more than two messages in FIFO, because of the characteristics of FIFO, the software needs to release the output mailbox to access the second message.<br>When the output mailbox is released, the hardware clears this bit. |
| 4         | FFOVR1   | FIFO 1 overrun<br>When FIFO 1 is full, a new message is received and the message meets the filtering conditions, the hardware sets this bit. This bit is cleared by software.  |

| Bit Field | Name       | Description   |
|-----------|------------|---|
| 3         | FFULL1     | FIFO 1 full<br>When there are 3 messages in FIFO 1, the hardware sets this bit. This bit is cleared by software.  |
| 2         | Reserved   | Reserved, the reset value must be maintained.   |
| 1:0       | FFMP1[1:0] | FIFO 1 message pending<br>Number of messages in FIFO 1 These two bits reflect the number of messages stored in the current receiving FIFO 1. Every time a new message is stored in receiving FIFO 1, the hardware adds 1 to CAN_RFF1.FFMP1.<br>Every time the software releases the output mailbox by writing '1' to CAN_RFF1.RFFOM1 bit, CAN_RFF1.FFMP1 is decremented by 1 until it is 0. |

### 20.7.3.6 CAN interrupt enable register (CAN\_INTE)

Address offset: 0x14

Reset value: 0x0000 0000

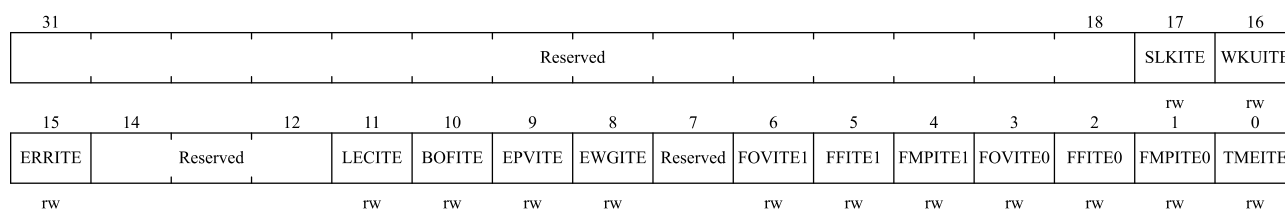

| Bit Field | Name     | Description  |
|-----------|----------|--|
| 31:18     | Reserved | Reserved, the reset value must be maintained.  |
| 17        | SLKITE   | Sleep interrupt enable<br>0: when the CAN_MSTS.SLAKINT bit is set, no interrupt is generated;<br>1: when the CAN_MSTS.SLAKINT bit is set, an interrupt is generated.   |
| 16        | WKUITE   | Wakeup interrupt enable<br>0: when CAN_MSTS.WKUINT bit is set, no interrupt is generated;<br>1: when CAN_MSTS.WKUINT bit is set, an interrupt is generated.  |
| 15        | ERRITE   | Error interrupt enable<br>0: When there is an error registration in the CAN_ESTS register, no interrupt is generated;<br>1: When there is an error registration in the CAN_ESTS register, an interrupt is generated.                                       |
| 14:12     | Reserved | Reserved, the reset value must be maintained.  |
| 11        | LECITE   | Last error code interrupt enable<br>0: When an error is detected, when the hardware sets CAN_ESTS.LEC[2:0], the CAN_MSTS.ERRINT bit is not set;<br>1: When an error is detected, when the hardware sets CAN_ESTS.LEC[2:0], the CAN_MSTS.ERRINT bit is set. |
| 10        | BOFITE   | Bus-off interrupt enable<br>0: When CAN_ESTS.BOFFL bit is set, CAN_MSTS.ERRINT bit is not set;<br>1: When the CAN_ESTS.BOFFL bit is set, set the CAN_MSTS.ERRINT bit.  |

| Bit Field | Name     | Description   |
|-----------|----------|---|
| 9         | EPVITE   | Error passive interrupt enable<br>0: when CAN_ESTS.EPVFL bit is set, CAN_MSTS.ERRINT bit is not set;<br>1: when CAN_ESTS.EPVFL bit is set, set the CAN_MSTS.ERRINT bit.   |
| 8         | EWGITE   | Error warning interrupt enable<br>0: When CAN_ESTS.EWGFL bit is set, CAN_MSTS.ERRINT bit is not set;<br>1: when the CAN_ESTS.EWGFL bit is set, set the CAN_MSTS.ERRINT bit.   |
| 7         | Reserved | Reserved, the reset value must be maintained.   |
| 6         | FOVITE1  | FIFO 1 overflow interrupt enable<br>0: When CAN_RFF1.FFOVR bit is set, no interrupt is generated;<br>1: When CAN_RFF1.FFOVR bit is set, an interrupt is generated.  |
| 5         | FFITE1   | FIFO 1 full interrupt enable<br>0: When CAN_RFF1.FFULL bit is set, no interrupt is generated;<br>1: When CAN_RFF1.FFULL bit is set, an interrupt is generated.  |
| 4         | FMPITE1  | FIFO 1 message pending interrupt enable<br>0: When CAN_RFF1.FFMP[1:0] bits are non-0, no interrupt is generated;<br>1: When CAN_RFF1.FFMP[1:0] bits are not 0, an interrupt is generated.   |
| 3         | FOVITE0  | FIFO 0 overflow interrupt enable<br>0: When CAN_RFF0.FFOVR bit is set, no interrupt is generated;<br>1: When CAN_RFF0.FFOVR bit is set, an interrupt is generated.  |
| 2         | FFITE0   | FIFO 0 full interrupt enable<br>0: When CAN_RFF0.FFULL bit is set, no interrupt is generated;<br>1: When CAN_RFF0.FFULL bit is set, an interrupt is generated.  |
| 1         | FMPITE0  | FIFO 0 message pending interrupt enable<br>0: When CAN_RFF0.FFMP[1:0] bits are non-0, no interrupt is generated;<br>1: When CAN_RFF0.FFMP[1:0] bits are not 0, an interrupt is generated.   |
| 0         | TMEITE   | Transmit mailbox empty interrupt enable.<br>0: When CAN_TSTS.RQCPMx bit is set, no interrupt is generated;<br>1: When CAN_TSTS.RQCPMx bit is set, an interrupt is generated.<br><i>Notes: Please refer to 20.5 Section CAN interrupt.</i> |

### 20.7.3.7 CAN error status register (CAN\_ESTS)

Address offset: 0x18

Reset value: 0x0000 0000

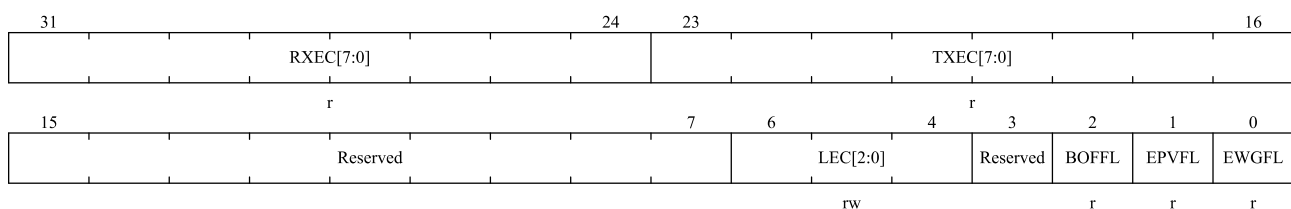

| Bit Field | Name      | Description  |
|-----------|-----------|--|
| 31:24     | RXEC[7:0] | Receive error counter<br>This counter is implemented according to the receiving part of the fault definition |

| Bit Field | Name      | Description  |
|-----------|-----------|--|
|           |           | mechanism of CAN protocol. According to the standard of CAN, when receiving error, the counter is incremented by 1 or incremented by 8 according to the error condition; After each successful reception, the counter is decremented by 1, or when the value of the counter is greater than 127, its value is set to 120. When the value of this counter exceeds 127, CAN enters the error passive state.  |
| 23:16     | TXEC[7:0] | Least significant byte of the 9-bit transmit error counter<br>Similar to the above, this counter is implemented according to the sending part of the fault definition mechanism of CAN protocol.   |
| 15:7      | Reserved  | Reserved, the reset value must be maintained.  |
| 6:4       | LEC[2:0]  | The Last error code.<br>When an error is detected on the CAN bus, the hardware is set according to the error situation. When the message is sent or received correctly, the hardware clears its value to '0'.<br>The hardware does not use error code 7, and the software can set this value, so that the code update can be detected.<br>000: there is no error;<br>001: Bit padding error;<br>010: wrong Format (form);<br>011: Acknowledgment (ack) error;<br>100: recessive dislocation (CAN transmits recessive but detect dominant on the bus) ;<br>101: dominant dislocation(CAN transmits dominant but detect recessive on the bus);<br>110: CRC error;<br>111: Set by software. |
| 3         | Reserved  | Reserved, the reset value must be maintained.  |
| 2         | BOFFL     | Bus-off flag<br>When going bus-off, hardware sets this bit. When the transmission error counter CAN_TSTS.TXEC overflows, that is, it is greater than 255, CAN goes bus-off.<br>Please refer to 20.5.1 section.   |
| 1         | EPVFL     | Error passive flag<br>When the number of errors reaches the threshold of error passivity, the hardware sets the bit.<br>(The value of the receiving error counter or the sending error counter is > 127).  |
| 0         | EWGFL     | Error warning flag<br>When the number of errors reaches the warning threshold, the hardware sets the bit.<br>(The value of the receiving error counter or the sending error counter is ≥96).   |

### 20.7.3.8 CAN bit timing register (CAN\_BTIM)

Address offset: 0x1C

Reset value: 0x0123 0000

*Notes: This register CAN only be accessed by software when CAN is in initialization mode.*



| Bit Field | Name      | Description  |
|-----------|-----------|--|
| 31        | SLM       | Silent mode (debug)<br>0: Normal state;<br>1: Silent mode.   |
| 30        | LBM       | Loop back mode (debug)<br>0: Loopback mode is prohibited;<br>1: Loopback mode is allowed.  |
| 29:26     | Reserved  | Reserved, the reset value must be maintained.  |
| 25:24     | RSJW[1:0] | Resynchronization jump width<br>For resynchronization, this bit field defines the upper limit of how many time units CAN be extended or shortened by CAN hardware in each bit.<br>$t_{RJW} = t_{CAN} \times (RSJW[1:0] + 1)$ .                   |
| 23        | Reserved  | Reserved, the reset value must be maintained.  |
| 22:20     | TBS2[2:0] | Time segment 2<br>This bit field defines how many time units time period 2 occupies.<br>$t_{BS2} = t_{CAN} \times (TBS2[2:0] + 1)$ .   |
| 19:16     | TBS1[3:0] | Time segment 1<br>This bit field defines how many time units time period 1 occupies.<br>$t_{BS1} = t_{CAN} \times (TBS1[3:0] + 1)$<br>For details of bit time characteristics, please refer to section 20.4.7 section: bit time characteristics. |
| 15:10     | Reserved  | Reserved, the reset value must be maintained.  |
| 9:0       | BRTP[9:0] | Baud rate prescaler<br>This bit field defines the time length of the time unit ( $t_q$ )<br>$t_q = (BRTP[9:0] + 1) \times t_{PCLK}$  |

## 20.7.4 CAN mailbox register

This section describes the sending and receiving mailbox registers. For more information about register mapping, refer to 20.4.6 section: message storage.

### 20.7.4.1 Tx mailbox identifier register(CAN\_TMIx)(x=0..2)

Address offset: 0x180, 0x190, 0x1A0

Reset value: 0xXXXX XXXX,X= undefined bit (except bit 0, TXRQ=0 at reset)

*Notes: 1.This register is write-protected when the mailbox to which it belongs is waiting to be sent;*

*2.This register implements the send request control function (bit 0)-the reset value is 0.*

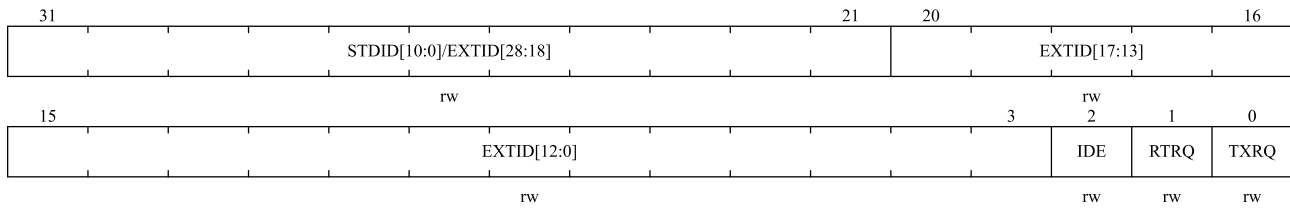

| Bit Field | Name                     | Description   |
|-----------|--------------------------|---|
| 31:21     | STDID[10:0]/EXTID[28:18] | Standard identifier or extended identifier<br>Depending on the content of CAN_TMIx.IDE bits, these bits are either standard identifiers or high bytes of extended identity.             |
| 20:3      | EXTID[17:0]              | Extended identifier<br>Low byte of extended identity.   |
| 2         | IDE                      | Identifier extension.<br>This bit determines the type of identifier used for sending messages in the mailbox.<br>0: Use standard identifier;<br>1: Use extended identifiers.            |
| 1         | RTRQ                     | The Remote transmission request<br>0: data frame;<br>1: Remote frame.   |
| 0         | TXRQ                     | Transmit mailbox request<br>It is set by the software to request to send the data of the mailbox. When the data transmission is completed and the mailbox is empty, hardware clears it. |

### 20.7.4.2 Tx mailbox data length and time stamp register (CAN\_TMDTx)(x=0..2)

When the mailbox is not empty, all bits in this register are write-protected.

Address offset: 0x184, 0x194, 0x1A4

Reset value: undefined

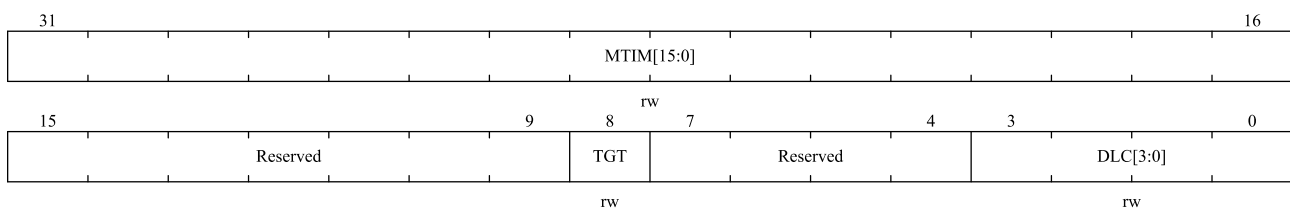

| Bit Field | Name       | Description  |
|-----------|------------|--|
| 31:16     | MTIM[15:0] | Message time stamp<br>This field contains the value of the 16-bit timer at the time of sending the message SOF.                              |
| 15:9      | Reserved   | Reserved, the reset value must be maintained.  |
| 8         | TGT        | Transmit global time<br>This bit is valid only when the CAN is in time-triggered communication mode, that is, the CAN_MCTRL.TTCM bit is set. |

| Bit Field | Name     | Description  |
|-----------|----------|--|
|           |          | 0: Do not send the time stamp CAN_TMDTx.MTIM[15:0];<br>1: send the time stamp CAN_TMDTx.MTIM[15:0]. In a message of length 8, the time stamp CAN_TMDTx.MTIM[15:0] is the last two bytes sent:<br>CAN_TMDTx.MTIM[7:0] is the seventh byte and CAN_TMDTx.MTIM[15:8] is the eighth byte. They replace the data written in CAN_TMDHx[31:16] (CAN_TMDLx.DATA6[7:0] and CAN_TMDLx.DATA7[7:0]). In order to send the 2 bytes of the timestamp, DLC must be programmed to 8. |
| 7:4       | Reserved | Reserved, the reset value must be maintained.  |
| 3:0       | DLC[3:0] | Data length code<br>This field specifies the data length of the data message or the data length requested by the remote frame. One message contains 0 to 8 bytes of data, which is determined by DLC.  |

### 20.7.4.3 Tx mailbox low byte data register(CAN\_TMDLx) (x=0..2)

When the mailbox is not empty, all bits in this register are write-protected.

Address offset: 0x188, 0x198, 0x1A8

Reset value: undefined

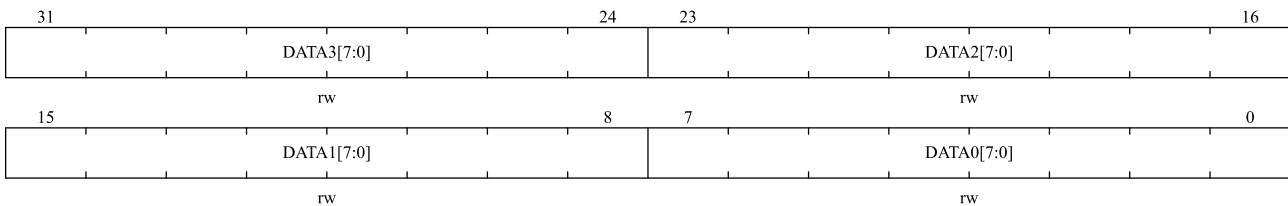

| Bit Field | Name       | Description  |
|-----------|------------|--|
| 31:24     | DATA3[7:0] | Data byte 3<br>Data byte 3 of the message.   |
| 23:16     | DATA2[7:0] | Data byte 2<br>Data byte 2 of the message.   |
| 15:8      | DATA1[7:0] | Data byte 1<br>Data byte 1 of the message.   |
| 7:0       | DATA0[7:0] | Data byte 0<br>Data byte 0 of the message.<br><i>Notes: the message contains 0 to 8 bytes of data, starting from byte 0.</i> |

### 20.7.4.4 Tx mailbox high byte data register(CAN\_TMDHx) (x=0..2)

When the mailbox is not empty, all bits in this register are write protected.

Address offset: 0x18c, 0x19c, 0x1ac

Reset value: undefined

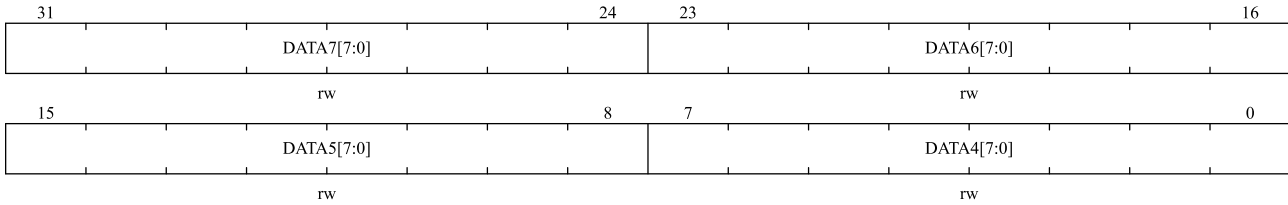

| Bit Field | Name       | Description   |
|-----------|------------|---|
| 31:24     | DATA7[7:0] | Data byte 7<br>Data byte 7 of the message.<br><i>Notes: If the CAN_MCTRL.TTCM bit is '1' and the CAN_TMDTx.TGT bit of this mailbox is also '1', then DATA7 and DATA6 will be replaced by TIME stamps.</i> |
| 23:16     | DATA6[7:0] | Data byte 6<br>Data byte 6 of the message.  |
| 15:8      | DATA5[7:0] | Data byte 5<br>Data byte 5 of the message.  |
| 7:0       | DATA4[7:0] | Data byte 4<br>Data byte 4 of the message.  |

#### 20.7.4.5 Receive FIFO mailbox identifier register (CAN\_RMIx) (x=0..1)

Address offset: 0x1B0, 0x1C0

Reset value: undefined

*Notes: All receiving mailbox registers are read-only.*

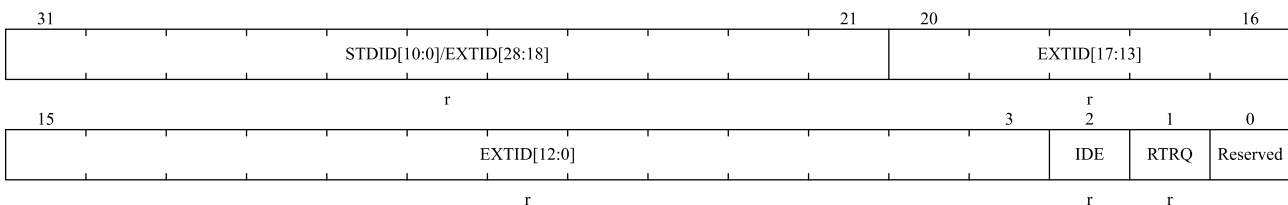

| Bit Field | Name                     | Description  |
|-----------|--------------------------|--|
| 31:21     | STDID[10:0]/EXTID[28:18] | Standard identifier or extended identifier<br>Depending on the content of CAN_RMIx.IDE bits, these bits are either standard identifiers or high bytes of extended identity.  |
| 20:3      | EXTID[17:0]              | Extended identifier<br>Low byte of extended identity.  |
| 2         | IDE                      | Identifier extension.<br>This bit determines the type of identifier used for sending messages in the mailbox.<br>0: Use standard identifier;<br>1: Use extended identifiers. |
| 1         | RTRQ                     | Remote transmission request<br>0: data frame;<br>1: Remote frame.  |

| Bit Field | Name     | Description                                   |
|-----------|----------|---|
| 0         | Reserved | Reserved, the reset value must be maintained. |

#### 20.7.4.6 Receive FIFO mailbox data length and time stamp register(CAN\_RMDTx)( x=0..1)

Address offset: 0x1B4, 0x1C4

Reset value: undefined

*Notes: All receiving mailbox registers are read-only.*

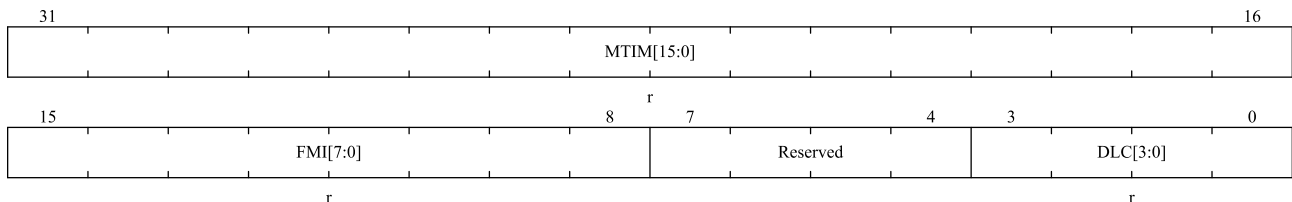

| Bit Field | Name       | Description   |
|-----------|------------|---|
| 31:16     | MTIM[15:0] | Message time stamp<br>This field contains the value of the 16-bit timer at the time of sending the message SOF.   |
| 15:8      | FMI[7:0]   | Filter match index<br>Here is the filter serial number of the information transfer stored in the mailbox.<br>For details of identifier filtering, please refer to 20.4.5 section: Identifier filtering. |
| 7:4       | Reserved   | Reserved, the reset value must be maintained.   |
| 3:0       | DLC[3:0]   | Data length code<br>This field indicates the data length (0~8) of the received data frame. For remote frame requests, the data length DLC is always 0.  |

#### 20.7.4.7 Receive FIFO mailbox low byte data register(CAN\_RMDLx)( x=0..1)

Address offset: 0x1B8, 0x1C8

Reset value: undefined

*Notes: All receiving mailbox registers are read-only.*

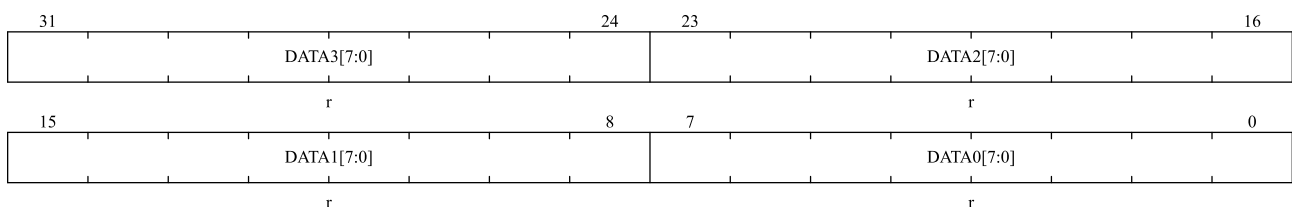

| Bit Field | Name       | Description                                |
|-----------|------------|--|
| 31:24     | DATA3[7:0] | Data byte 3<br>Data byte 3 of the message. |
| 23:16     | DATA2[7:0] | Data byte 2<br>Data byte 2 of the message. |
| 15:8      | DATA1[7:0] | Data byte 1                                |

| Bit Field | Name       | Description   |
|-----------|------------|---|
|           |            | Data byte 1 of the message.   |
| 7:0       | DATA0[7:0] | Data byte 0<br>Data byte 0 of the message.<br>Notes: the message contains 0 to 8 bytes of data, starting from byte 0. |

### 20.7.4.8 Receive FIFO mailbox high byte data register(CAN\_RMDHx) (x=0..1)

Address offset: 0x1BC, 0x1CC

Reset value: undefined

*Note: All receiving mailbox registers are read-only.*

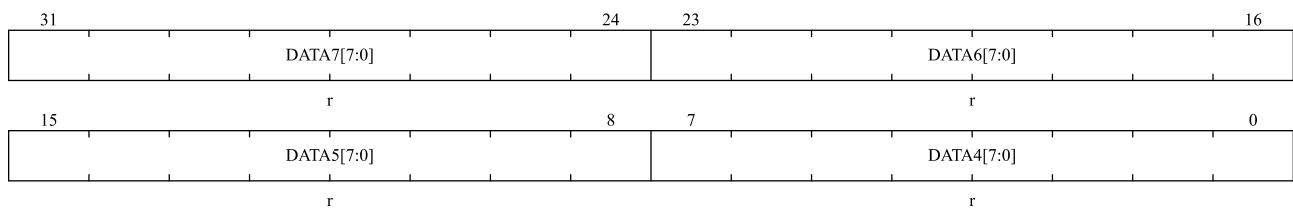

| Bit Field | Name       | Description                                |
|-----------|------------|--|
| 31:24     | DATA7[7:0] | Data byte 7<br>Data byte 7 of the message. |
| 23:16     | DATA6[7:0] | Data byte 6<br>Data byte 6 of the message. |
| 15:8      | DATA5[7:0] | Data byte 5<br>Data byte 5 of the message. |
| 7:0       | DATA4[7:0] | Data byte 4<br>Data byte 4 of the message. |

## 20.7.5 CAN filter register

### 20.7.5.1 CAN filter master control register (CAN\_FMC)

Address offset: 0x200

Reset value: 0x2A1C 0E01

*Notes: The unreserved bits of this register are completely controlled by software.*

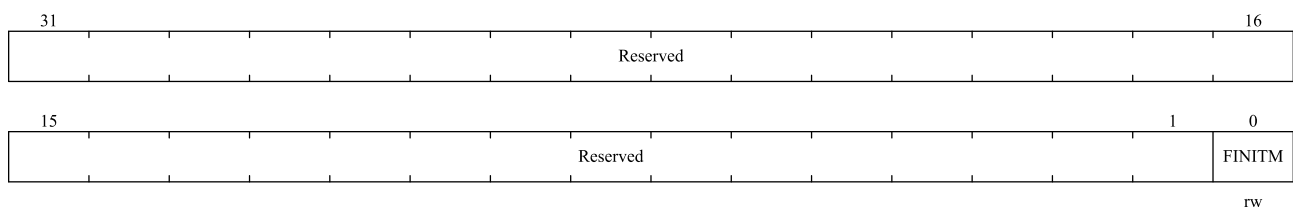

| Bit Field | Name     | Description                                   |
|-----------|----------|---|
| 31:1      | Reserved | Reserved, the reset value must be maintained. |
| 0         | FINITM   | Filter init mode                              |

| Bit Field | Name | Description   |
|-----------|------|---|
|           |      | Initialization mode settings for all filter groups.<br>0: The filter group works in normal mode;<br>1: The filter group works in initialization mode. |

### 20.7.5.2 CAN filter mode register (CAN\_FM1)

Address offset: 0x204

Reset value: 0x0000 0000

*Notes: You can only write to this register when you set CAN\_FMC.FINITM bit and put the filter in initialization mode.*

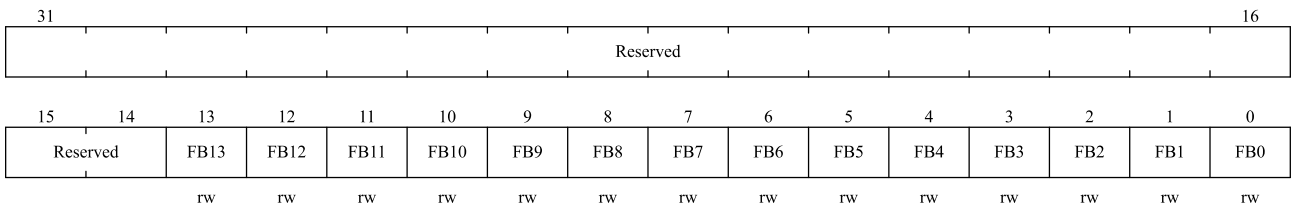

| Bit Field | Name     | Description   |
|-----------|----------|---|
| 31:28     | Reserved | Reserved, the reset value must be maintained.   |
| 13:0      | FBx      | Filter mode<br>Working mode of filter group X<br>0: Two 32-bit registers of CAN_FiRx work in identifier mask mode;<br>1: Two 32-bit registers of CAN_FiRx work in identifier list mode. |

### 20.7.5.3 CAN filter scale register (CAN\_FS1)

Address offset: 0x20C

Reset value: 0x0000 0000

*Notes: You can only write to this register when you set CAN\_FMC.FINITM bit and put the filter in initialization mode.*

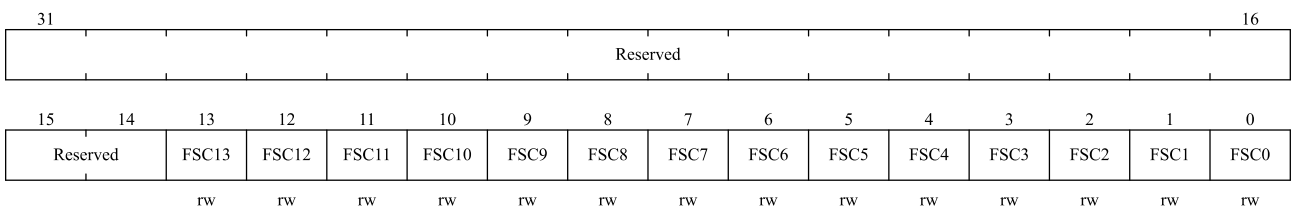

| Bit Field | Name     | Description   |
|-----------|----------|---|
| 31:28     | Reserved | Reserved, the reset value must be maintained.   |
| 13:0      | FSCx     | Filter scale configuration<br>Bit width of filter group x (13~0).<br>0: The filter bit width is 2 16-bits;<br>1: The filter bit width is a single 32-bit. |

### 20.7.5.4 CAN filter FIFO assignment register (CAN\_FFA1)

Address offset: 0x214

Reset value: 0x0000 0000

*Notes: You can only write to this register when you set CAN\_FMC.FINITM bit and put the filter in initialization mode.*

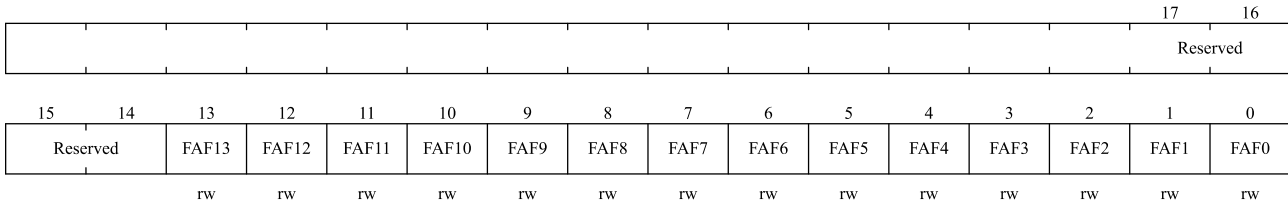

| Bit Field | Name     | Description   |
|-----------|----------|---|
| 31:28     | Reserved | Reserved, the reset value must be maintained.   |
| 13:0      | FAFx     | Filter FIFO assignment for filter x<br>After the message is filtered by a certain filter, it will be stored in its associated FIFO.<br>0: the filter is associated to FIFO0;<br>1: the filter is associated to FIFO1. |

### 20.7.5.5 CAN filter activation register (CAN\_FA1)

Address offset: 0x21C

Reset value: 0x0000 0000

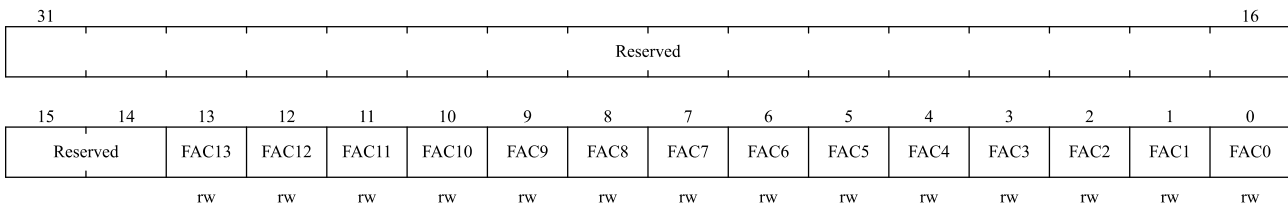

| Bit Field | Name     | Description  |
|-----------|----------|--|
| 31:28     | Reserved | Reserved, the reset value must be maintained.  |
| 13:0      | FACx     | Filter active<br>The software sets '1' for someone to activate the corresponding filter. The corresponding filter register i(CAN_FiR[2:1]) can only be modified after the CAN_FA1.FACx bit is cleared or the CAN_FMC.FINITM bit is set.<br>0: The filter is disabled;<br>1: The filter is activated. |

### 20.7.5.6 CAN filter i register x (CAN\_FiRx) (i=0..13;x=1..2)

Address offset: 0x240h, 0x31C

Reset value: undefined

*Notes: 14 groups of filters: i = 0 ... 13. Each group of filters consists of two 32-bit registers, CAN\_FiR[2:1].*

Only when the corresponding *CAN\_FAI.FACx* bit is cleared or the *CAN\_FMC.FINIT* bit is set, the corresponding filter register can be modified.

|       |       |       |       |       |       |       |       |       |       |       |       |       |       |       |       |
|-------|-------|-------|-------|-------|-------|-------|-------|-------|-------|-------|-------|-------|-------|-------|-------|
| 31    | 30    | 29    | 28    | 27    | 26    | 25    | 24    | 23    | 22    | 21    | 20    | 19    | 18    | 17    | 16    |
| FBC31 | FBC30 | FBC29 | FBC28 | FBC27 | FBC26 | FBC25 | FBC24 | FBC23 | FBC22 | FBC21 | FBC20 | FBC19 | FBC18 | FBC17 | FBC16 |
| rw    | rw    | rw    | rw    | rw    | rw    | rw    | rw    | rw    | rw    | rw    | rw    | rw    | rw    | rw    | rw    |
| 15    | 14    | 13    | 12    | 11    | 10    | 9     | 8     | 7     | 6     | 5     | 4     | 3     | 2     | 1     | 0     |
| FBC15 | FBC14 | FBC13 | FBC12 | FBC11 | FBC10 | FBC9  | FBC8  | FBC7  | FBC6  | FBC5  | FBC4  | FBC3  | FBC2  | FBC1  | FBC0  |
| rw    | rw    | rw    | rw    | rw    | rw    | rw    | rw    | rw    | rw    | rw    | rw    | rw    | rw    | rw    | rw    |

| Bit Field | Name      | Description   |
|-----------|-----------|---|
| 31:0      | FBC[31:0] | <p>Filter bits</p> <p>Identifier pattern</p> <p>Each bit of the register corresponds to the level of the corresponding bit of the expected identifier.</p> <p>0: the corresponding bit is expected to be dominant;</p> <p>1: The corresponding bit is expected to be recessive.</p> <p>Mask bit pattern</p> <p>Each bit of the register indicates whether the corresponding identifier register bit must be consistent with the corresponding bit of the expected identifier.</p> <p>0: Don't care, this bit is not used for comparison;</p> <p>1: Must match, and the incoming identifier bit must be consistent with the identifier register bit corresponding to the filter.</p> |

**Notes:** According to the different settings of filter bit width and mode, the functions of the two registers in the filter bank are different. For the mapping of filters, function description and association of mask registers, see 20.4.5 Section: identifier filtering.

Mask/identifier register in **mask mode** has the same definition as register bit in **identifier list mode**.

See for the address of the filter bank register Table 20-4.

## 21 Serial peripheral interface/Inter-IC Sound (SPI/ I<sup>2</sup>S)

### 21.1 Introduction

This module is about SPI/I<sup>2</sup>S. It works in SPI mode by default and users can choose to use I<sup>2</sup>S by setting the value of registers.

Serial peripheral interface (SPI) is able to work in master or slave mode, support full-duplex and simplex high-speed communication mode, and have hardware CRC calculation and configurable multi-master mode.

On-chip audio interface (I<sup>2</sup>S) is able to work in master and slave modes in simplex communication, and supports four audio standards: Philips I<sup>2</sup>S standard, MSB alignment standard, LSB alignment standard and PCM standard.

Both of them are synchronous serial interface communication protocols.

### 21.2 Main features

#### 21.2.1 SPI features

- Full duplex mode and simplex synchronous mode.
- Support master mode, slave mode and multi-master mode.
- Supports 8-bit or 16-bit data frame format.
- Data bit sequence programmable.
- NSS management by hardware or software.
- Clock polarity and phase programmable.
- Sending and receiving support hardware CRC calculation and check.
- Supports DMA function.

#### 21.2.2 I<sup>2</sup>S features

- Simplex synchronous mode.
- Supports master mode and slave mode operation.
- Four audio standards are supported: Philips I<sup>2</sup>S standard, MSB alignment standard, LSB alignment standard and PCM standard.
- The audio sampling frequency from 8kHz to 96kHz can be configured.
- Supports 16-bit, 24-bit or 32-bit data length and data frame format (configured according to requirements).
- Steady state clock polarity programmable.
- The data direction is always MSB first.
- Supports DMA function.

## 21.3 SPI function description

### 21.3.1 General description

Figure 21-1 SPI block diagram

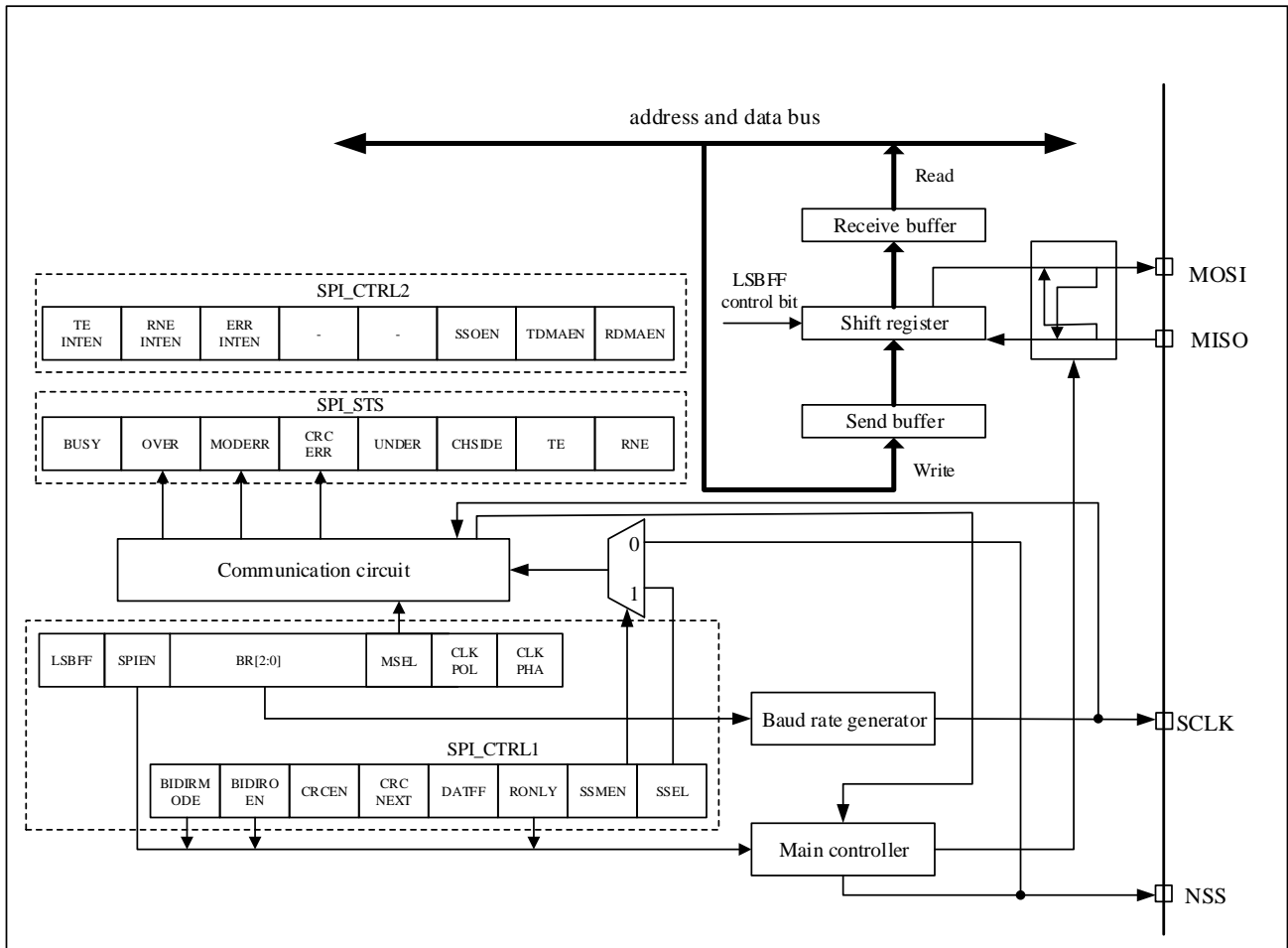

To connected external devices, SPI has four pins, which are as follows:

- **SCLK:** serial clock pin. Serial clock signal is output from the SCLK pin of master device and input to SCLK pin of slave device.
- **MISO:** master input/slave output pin. Data is received from the MISO pin of master device and send by the MISO pin of slave device.
- **MOSI:** master output/slave input pin. Data is send by the MOSI pin of master device and received from the MOSI pin of slave device.
- **NSS:** chip select pin. There are two types of NSS pin, internal pin and external pin. If the internal pin detects a high level, SPI works in the master mode. Conversely, SPI works in the slave mode. Users can use a standard I/O pin of the master device to control the NSS pin of the slave device.

#### Software NSS mode

The software slave device management is enabled when `SPI_CTRL1.SSMEN = 1`.

The NSS pin is not used in software NSS mode. In this mode the internal NSS signal level is driven by writing the SPI\_CTRL1.SSEL bit (master mode SPI\_CTRL1.SSEL = 1, slave mode SPI\_CTRL1.SSEL = 0).

### Hardware NSS mode

The software slave device management is disabled when SPI\_CTRL1.SSMEN = 0.

NSS input mode: The NSS output of the master device is disabled (SPI\_CTRL1.MSEL = 1, SPI\_CTRL2.SSOEN = 0), allowing operation in multi-master mode. The master should connect NSS pin to the high level and the slave should connect NSS pin to the low level during the entire data frame transfer.

NSS output mode: NSS output of the master device is enable (SPI\_CTRL1.MSEL = 1, SPI\_CTRL2.SSOEN = 1). SPI as the master device must pull the NSS pin to low level, all device which connected to the master device and set to NSS hardware mode, will detect low level and enter the slave mode automatically. If the master device cannot pull the NSS pin to low level, device will enter the slave mode and generates the master mode failure error.

*Note: The choice of software mode or hardware mode depends on whether NSS control is needed in the communication protocol. If not, you can choose the software mode, and release a GPIO pin for other purposes.*

Figure 21-2 Selective management of hardware/software

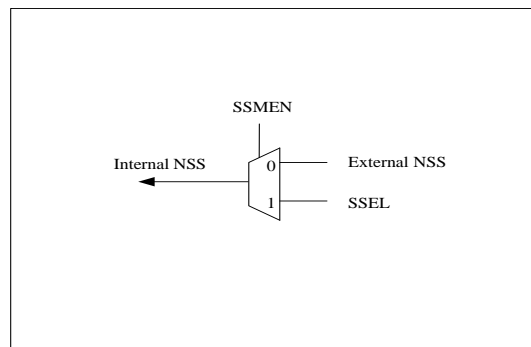

The following figure is an example of the interconnection of single master and single slave devices

Figure 21-3 Master and slave applications

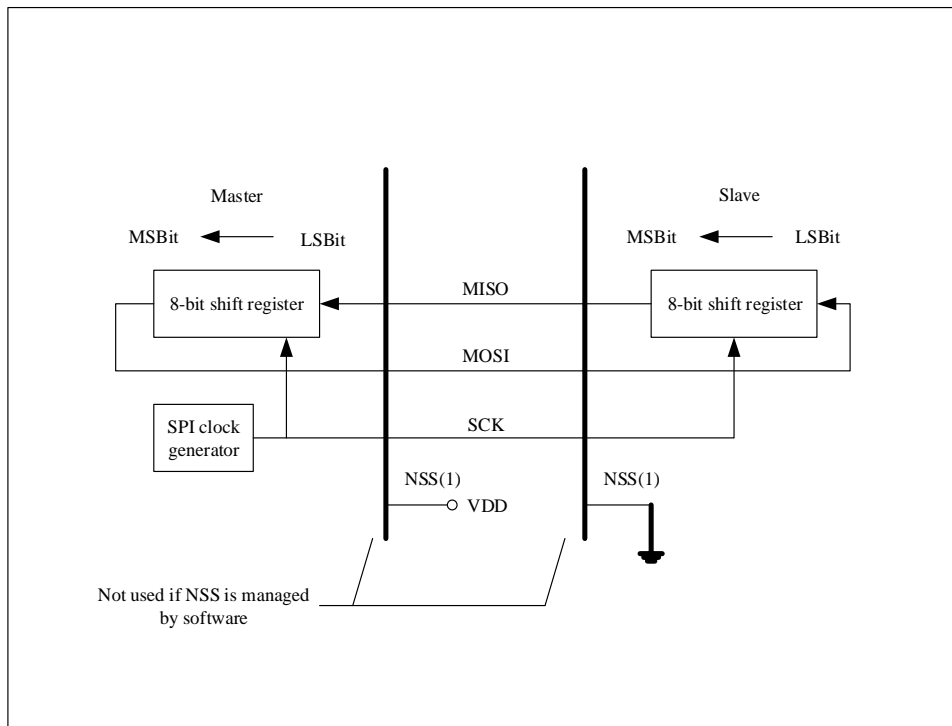

*Note: NSS pin is set as input*

SPI is a ring bus structure. The master device outputs a synchronous clock signal through the SCK pin, the MOSI pin of the master device is connected to the MOSI pin of the slave device, and the MISO pin of the master device is connected to the MISO pin of the slave device, so that data can be transferred between devices. Continuous data transfer between master and slave, sending data to slave through MOSI pin and slave sending data to master through MISO pin.

### SPI timing mode

User can select the clock edge of data capture by setting SPI\_CTRL1.CLKPOL bit and SPI\_CTRL1.CLKPHA bit.

- When CLKPOL = 0, CLKPHA = 0, the SCLK pin will keep low in idle state, and the data will be sampled at the first edge, which is rising edge.
- When CLKPOL = 0, CLKPHA = 1, the SCLK pin will keep low in idle state, and the data will be sampled at the second edge, which is falling edge.
- When CLKPOL = 1, CLKPHA = 0, the SCLK pin will keep high in idle state, and the data will be sampled at the first edge, which is falling edge.
- When CLKPOL = 1, CLKPHA = 1, the SCLK pin will keep high in idle state, and the data will be sampled at the second edge, which is rising edge.

Regardless of the timing mode used, the master and slave configuration must be the same.

Figure 21-4 is the combination timing of four CLKPHA and CLKPOL bits transmitted by SPI when the SPI\_CTRL1.LSBFF = 0.

Figure 21-4 Data clock timing diagram

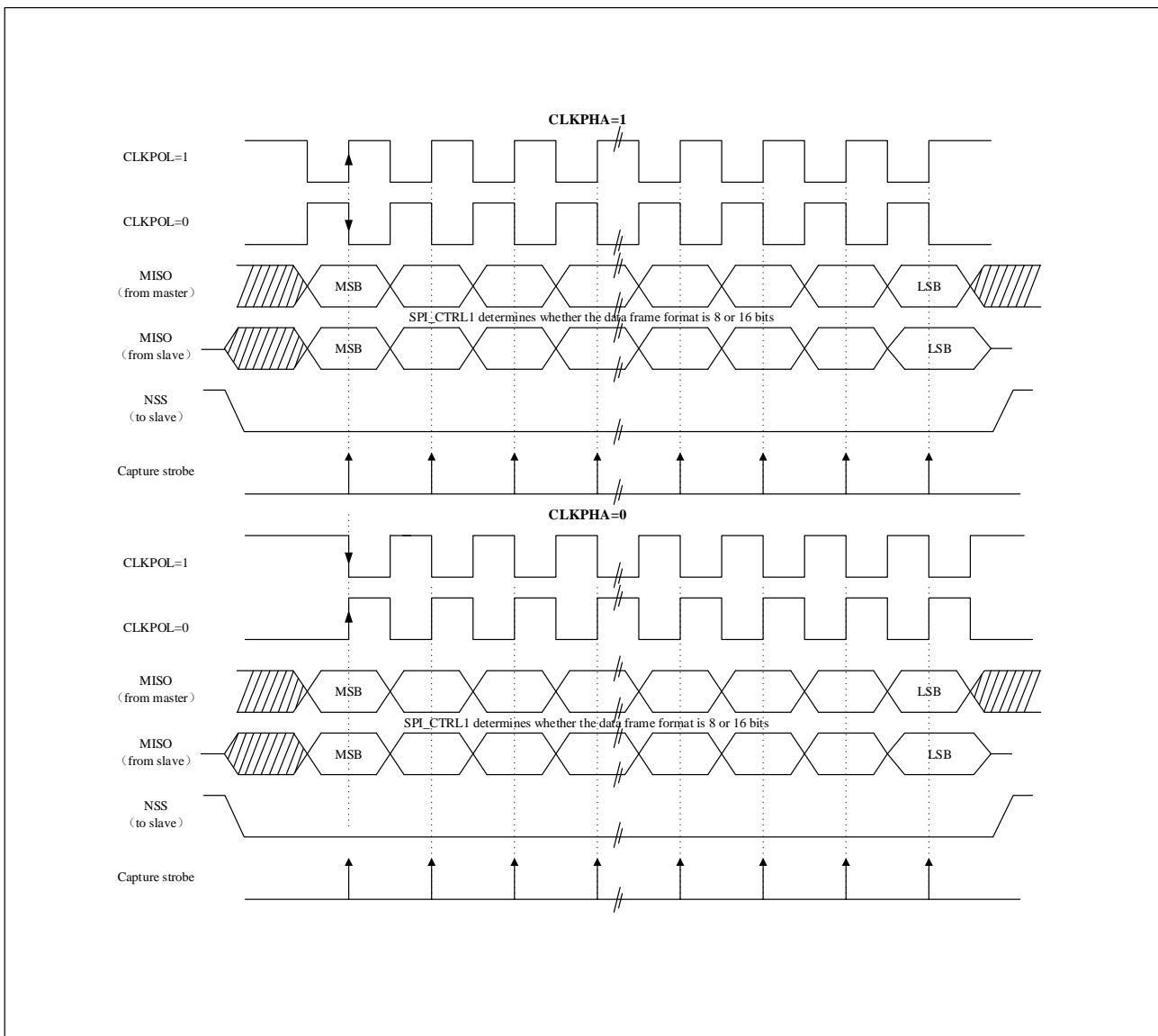

### Data format

User can select the data order by setting the `SPI_CTRL1.LSBFF` bit. When `SPI_CTRL1.LSBFF = 0`, SPI will send the high-order data (MSB) first; When `SPI_CTRL1.LSBFF = 1`, SPI will send low-order data (LSB) first.

User can select the data frame by setting the `SPI_CTRL1.DATFF` bit.

### 21.3.2 SPI work mode

- **Master full duplex mode** (`SPI_CTRL1.MSEL = 1`, `SPI_CTRL1.BIDIRMODE = 0`, `SPI_CTRL1.ONLY = 0`)

After the first data is written to the `SPI_DAT` register, the transmission will start. When the first bit of the data is sent, the data bytes are loaded from the data register into the shift register in parallel, and then according to the configuration of the `SPI_CTRL1.LSBFF` bit, the data bits follow the MSB or LSB order and are serially shifted to the MOSI pin. At the same time, the data received on the MISO pin is serially shifted into the shift register in the same order and then loaded into the `SPI_DAT` register in parallel. The software operation process is as follows:

1. Set SPI\_CTRL1.SPIEN = 1, Enable SPI module.
2. Write the first data to be sent into SPI\_DAT register (this operation will clear SPI\_STS.TE bit).
3. Wait for SPI\_STS.TE bit to be set to '1', and write the second data to be sent into SPI\_DAT. Wait for SPI\_STS.RNE bit to be set to '1', read SPI\_DAT to get the first received data, and the SPI\_STS.RNE bit will be cleared by hardware while reading SPI\_DAT. Repeat the above operation, sending subsequent data and receiving n-1 data at the same time;
4. Wait for SPI\_STS.RNE bit to be set to '1' to receive the last data;
5. Wait for SPI\_STS.TE to be set to '1', then wait for SPI\_STS.BUSY bit to be cleared and turn off SPI module.

The process of data sending and data receiving can also be implemented in the interrupt handler generated by the rising edge of the SPI\_STS.RNE or SPI\_STS.TE flag.

Figure 21-5 Schematic diagram of the change of TE/RNE/BUSY when the host is continuously transmitting in full duplex mode

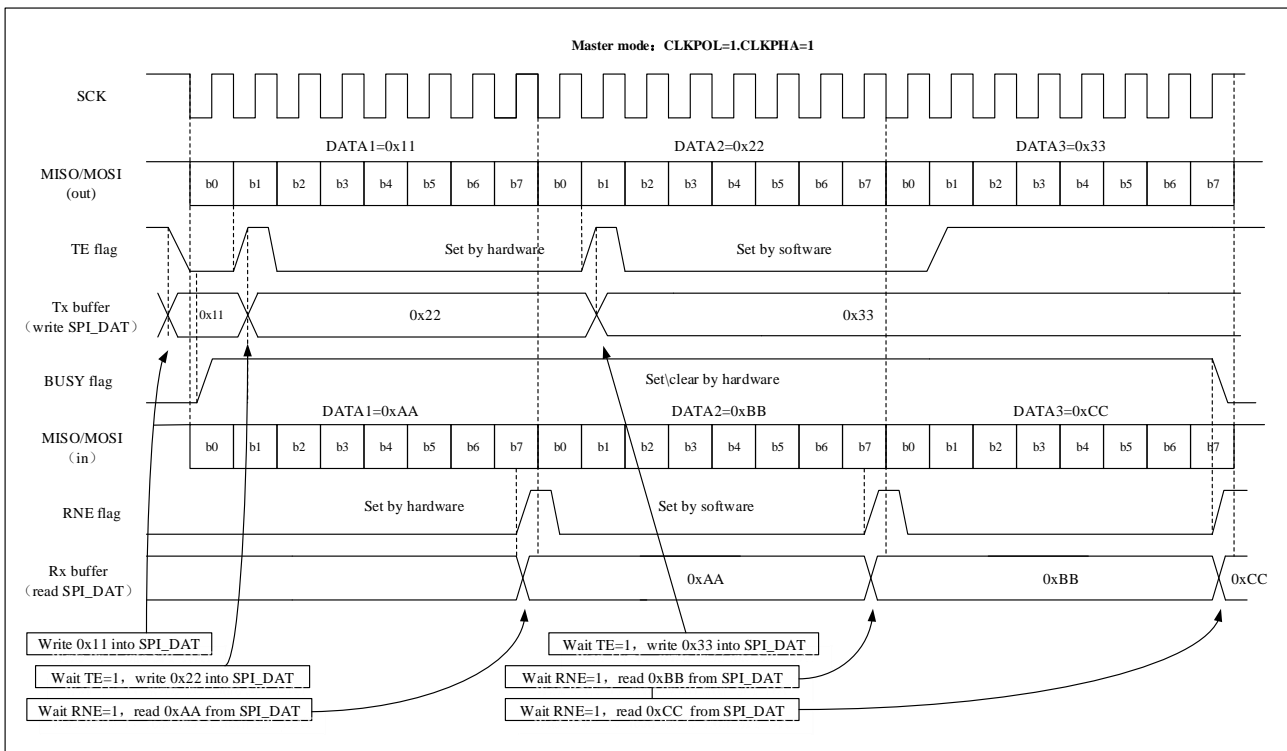

■ **Master two-wire one-way send-only mode (SPI\_CTRL1.MSEL = 1, SPI\_CTRL1.BIDIRMODE = 0, SPI\_CTRL1.ONLY = 0)**

Master two-wire one-way send-only mode is similar to master full-duplex mode. The difference is that this mode will not read the received data, so the SPI\_STS.OVER bit will be set to '1', and the software will ignore it. The software operation process is as follows:

1. Set SPI\_CTRL1.SPIEN = 1, Enable SPI module.
2. Write the first data to be sent into SPI\_DAT register (this operation will clear SPI\_STS.TE bit).
3. Wait for SPI\_STS.TE bit to be set to '1', and write the second data to be sent into SPI\_DAT. Repeat this operation to send subsequent data;

- After writing the last data to SPI\_DAT, wait for SPI\_STS.TE bit to set '1'; then wait for SPI\_STS.BUSY bit to be cleared to complete the transmission of all data.

The process of data sending can also be implemented in the interrupt handler generated by the rising edge of the TE flag.

Figure 21-6 Schematic diagram of TE/BUSY change when the host transmits continuously in one-way only mode

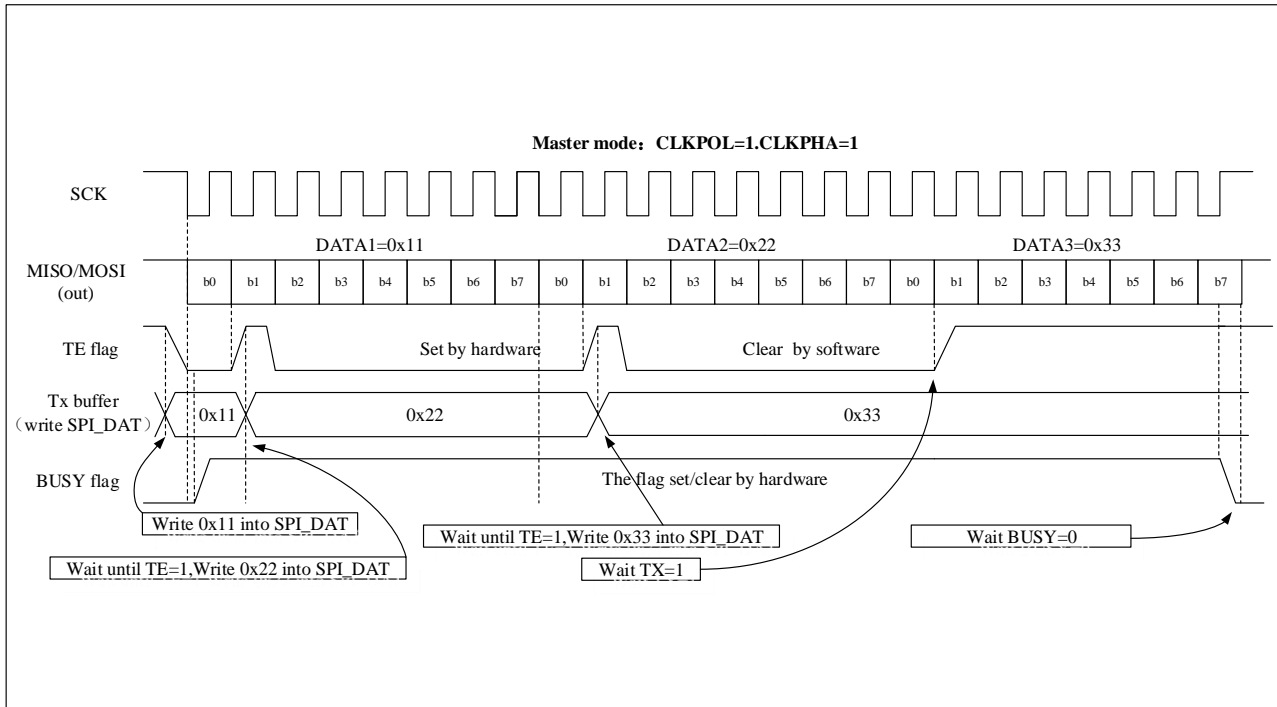

■ **Master two-wire one-way receive-only mode (SPI\_CTRL1.MSEL = 1, SPI\_CTRL1.BIDIRMODE = 0, SPI\_CTRL1.ONLY = 1)**

When SPI\_CTRL1.SPIEN = 1, the receiving process starts. The data bits from the MISO pin are sequentially shifted into the shift register and then loaded into the SPI\_DAT register (receive buffer) in parallel. The software operation process is as follows:

Enable the receive-only mode (SPI\_CTRL1.ONLY = 1).

Enable SPI module, set SPI\_CTRL1.SPIEN = 1: in master mode, SCLK clock signal is generated immediately, and serial data is continuously received before SPI is turned off (SPI\_CTRL1.SPIEN = 0); in slave mode, serial data is continuously received when the SPI master device pulls low the NSS signal and generates SCLK clock.

Wait for SPI\_STS.RNE bit to be set to '1', read the SPI\_DAT register to get the received data, and the SPI\_STS.RNE bit will be cleared by hardware while reading SPI\_DAT register. Repeat this operation to receive all data.

The process of data receiving can also be implemented in the interrupt handler generated by the rising edge of the RNE flag (SPI\_STS.RNE).

Figure 21-7 Schematic diagram of RNE change when continuous transmission occurs in receive-only mode (BIDIRMODE = 0 and

RONLY = 1)

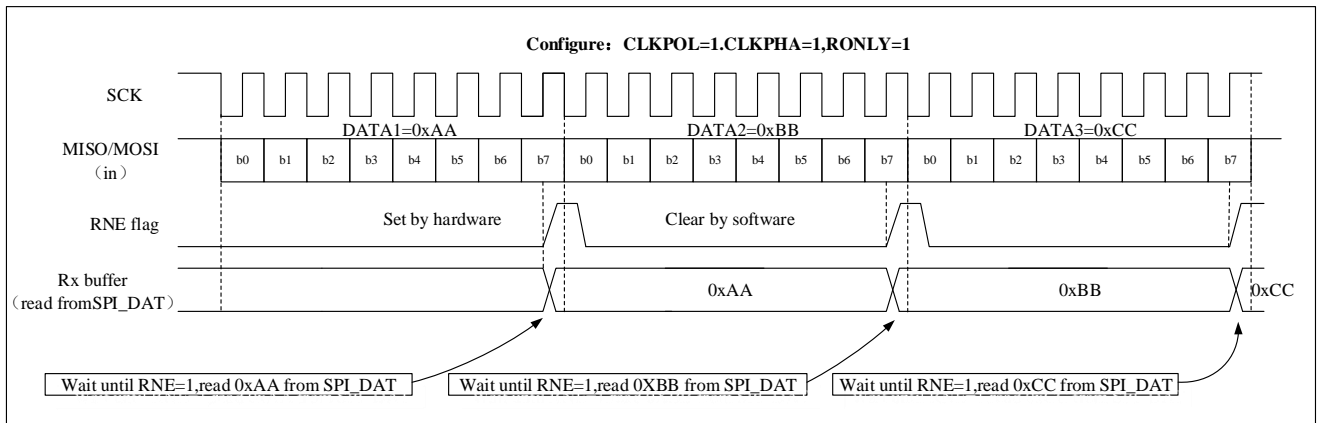

■ **Master one-wire bidirectional send mode (SPI\_CTRL1.MSEL = 1, SPI\_CTRL1.BIDIRMODE = 1, SPI\_CTRL1.BIDIROEN = 1, SPI\_CTRL1.RONLY = 0)**

After the data is written to the SPI\_DAT register (send buffer), the transmission process starts. This mode does not receive data. At the same time as the first data bit is sent, the data to be sent is loaded into the shift register in parallel, and then according to the configuration of the SPI\_CTRL1.LSBFF bit, the SPI serially shifts the data bits to the MOSI pin in MSB or LSB order

The software operation flow of the master one-wire bidirectional send mode is the same as that of the send-only mode.

■ **Master one-wire bidirectional receive mode (SPI\_CTRL1.MSEL = 1, SPI\_CTRL1.BIDIRMODE = 1, SPI\_CTRL1.BIDIROEN = 0, SPI\_CTRL1.RONLY = 0)**

When SPI\_CTRL1.SPIEN = 1, the receiving process starts. There is no data output in this mode, the received data bits are sequentially and serially shifted into the shift register, and then loaded into the SPI\_DAT register (receive buffer) in parallel

The software operation flow of the master one-wire bidirectional receive mode is the same as that of the receive-only mode.

■ **Slave full duplex mode (SPI\_CTRL1.MSEL = 0, SPI\_CTRL1.BIDIRMODE = 0, SPI\_CTRL1.RONLY = 0)**

The data transfer process begins when the slave device receives the first clock edge. Before the master starts data transfer, software must ensure that the data to be send is written to the SPI\_DAT register.

Figure 21-8 Schematic diagram of the change of TE/RNE/BUSY when the slave is continuously transmitting in full duplex mode

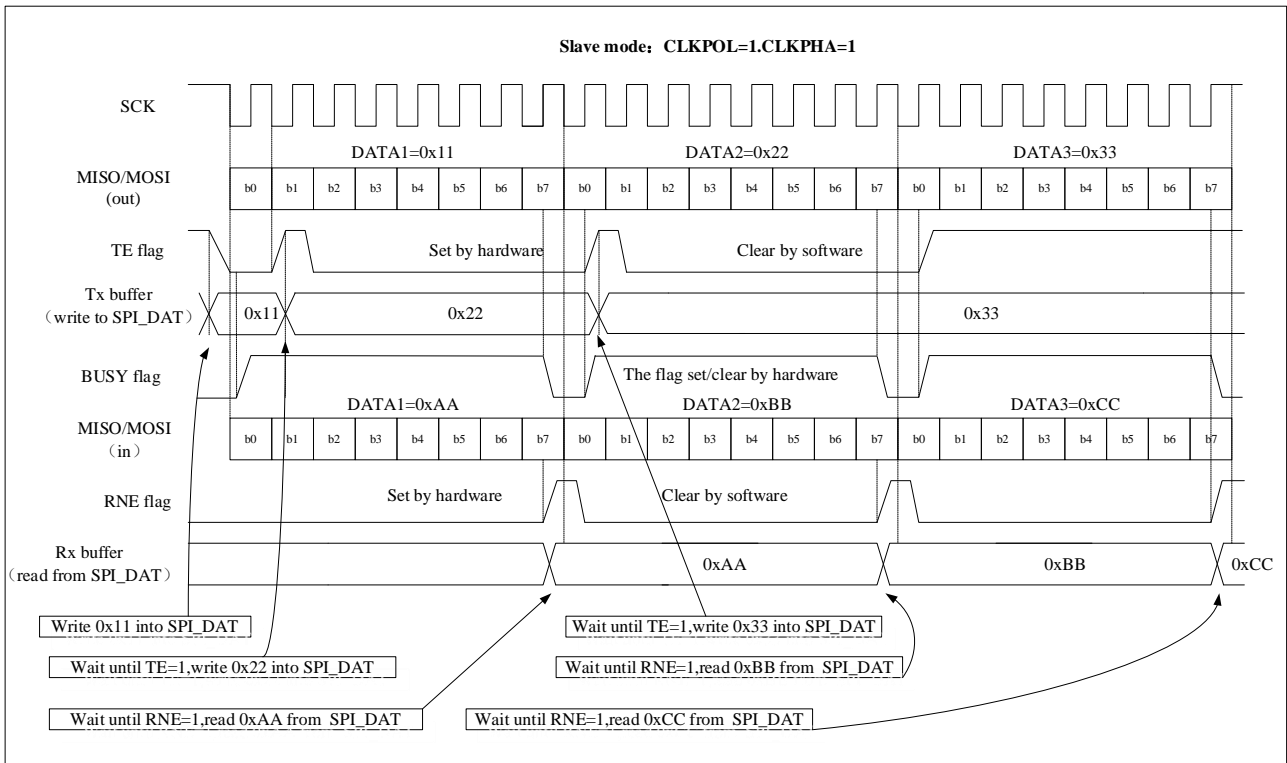

■ **Slave two-wire one-way send-only mode (SPI\_CTRL1.MSEL = 0, SPI\_CTRL1.BIDIRMODE = 0 and SPI\_CTRL1.ONLY = 0)**

Figure 21-9 Schematic diagram of TE/BUSY change during continuous transmission in slave unidirectional transmit-only mode

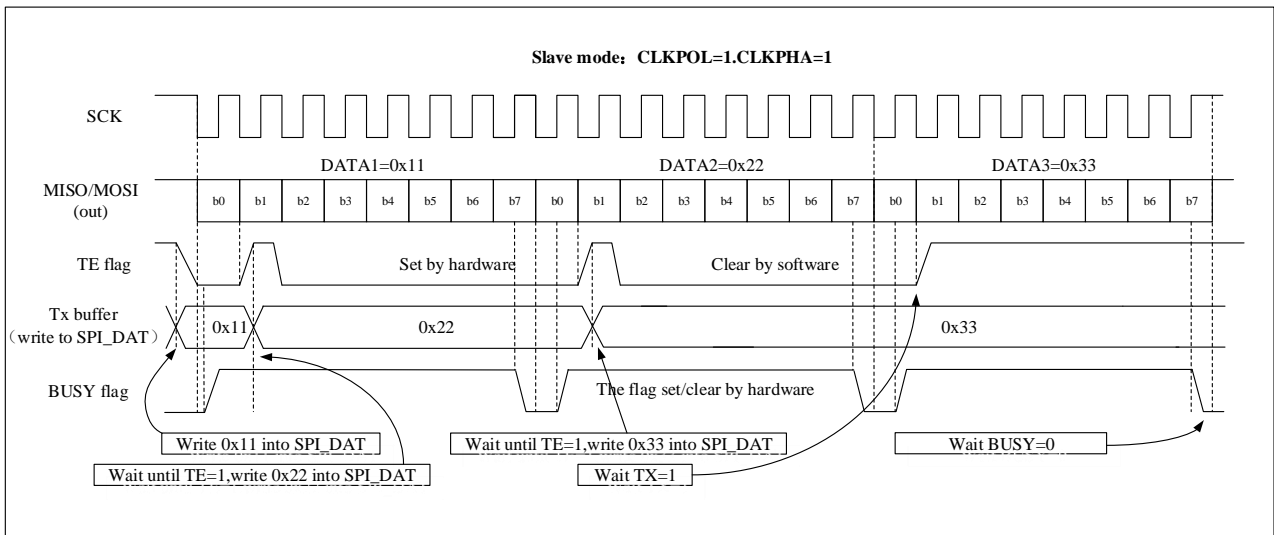

■ **Slave two-wire one-way receive-only mode (SPI\_CTRL1.MSEL = 0, SPI\_CTRL1.BIDIRMODE = 0 and SPI\_CTRL1.ONLY = 1)**

The data receiving process begins when the slave device receives the clock signal and the first data bit from the MOSI pin. The received data bits are sequentially and consecutively shifted serially into an shift register and then loaded into the SPI\_DAT register (receive buffer) in parallel.

■ **Slave one-wire bidirectional send mode (SPI\_CTRL1.MSEL = 0, SPI\_CTRL1.BIDIRMODE = 1 and**

**SPI\_CTRL1.BIDIROEN = 1)**

When the slave device receives the first edge of the clock signal, the sending process starts. No data is received in this mode, and the software must ensure that the data to be sent has been written in the SPI\_DAT register before the SPI master device starts data transmission.

**■ Slave one-wire bidirectional receive mode (SPI\_CTRL1.MSEL = 0, SPI\_CTRL1.BIDIRMODE = 1 and SPI\_CTRL1.BIDIROEN = 0)**

Data receiving begins when the slave device receives the first clock edge and a data bit from the MOSI pin. There is no data output in this mode, the received data bits are sequentially and consecutively shifted serially into a shift register, and then loaded into the SPI\_DAT register (receive buffer) in parallel.

Note: The software operation process of the slave can refer to the master.

**SPI initialization process**

1. The baud rate of serial clock is defined by the SPI\_CTRL1.BR[2:0] bits (this step is ignored if it is working in slave mode).
2. Select SPI\_CTRL1.CLKPOL bit and SPI\_CTRL1.CLKPHA bit to define the phase relationship between data transmission and serial clock (see Figure 21-4).
3. Set SPI\_CTRL1.DATFF bit to define 8-bit or 16-bit data frame format.
4. Configure the SPI\_CTRL1.LSBFF bit to define the frame format.
5. Configure the NSS mode as described above for the NSS function.
6. Run mode is configured by SPI\_CTRL1.MSEL bit, SPI\_CTRL1.BIDIRMODE bit, SPI\_CTRL1.BIDIROEN bit and SPI\_CTRL1.ROONLY bit.
7. Set the SPI\_CTRL1.SPIEN = 1 to enable SPI.

**Basic send and receive process**

When SPI sends a data frame, it first loads the data frame from the data buffer into the shift register, and then starts to send the loaded data. When the data is transferred from the send buffer to the shift register, the send buffer empty flag is set (SPI\_STS.TE = 1), and the next data can be loaded into the send buffer; if the TEINTEN bit is set (SPI\_CTRL2.TEINTEN = 1), an interrupt will be generated; writing data to the SPI\_DAT register will clear the SPI\_STS.TE bit.

At the last edge of the sampling clock, when the data is transferred from the shift register to the receive buffer, the receive buffer non-empty flag is set (SPI\_STS.RNE = 1), at this time the data is ready and can be read from the SPI\_DAT register; if the receive buffer non-empty interrupt is enabled (SPI\_CTRL2.RNEINTEN = 1), an interrupt will be generated; the SPI\_STS.RNE bit can be cleared by reading the SPI\_DAT register data.

In master mode, the sending process starts when data is written to the send buffer. If the next data has been written into the SPI\_DAT register before the current data frame sending is completed, the continuous sending function can be achieved.

In slave mode, the NSS pin is low, and when the first clock edge arrives, the transmission process begins. In order to avoid accidental data transmission, software must write data to the transmit buffer before data transmission (it is recommended to enable the SPI module before the host sends the clock).

In some configurations, when the last data is sent, the BUSY flag (SPI\_STS.BUSY) can be used to wait for the end of the data sending.

### Continuous and discontinuous transmission.

When sending data in master mode, if the software is fast enough to detect each TE (SPI\_STS.TE) rising edge (or TE interrupt), and the data is written to the SPI\_DAT register immediately before the end of the ongoing transmission. At this time, the SPI clock remains continuous between the transmission of data items, and the SPI\_STS.BUSY bit will not be cleared, continuous communication can be achieved.

If the software is not fast enough, it will result in discontinuous communication; in this case, the SPI\_STS.BUSY bit is cleared between the transmission of each data items (see Figure 21-10 below).

In master receive-only mode (SPI\_CTRL1.ROONLY = 1), communication is always continuous and the BUSY flag (SPI\_STS.BUSY) is always high.

In slave mode, the continuity of communication is determined by the SPI master device. However, even if the communication is continuous, the BUSY flag (SPI\_STS.BUSY) will be low for at least one SPI clock cycle between each data item (see Figure 21-9).

Figure 21-10 Schematic diagram of TE/BUSY change when BIDIRMODE = 0 and ROONLY = 0 are transmitted discontinuously.

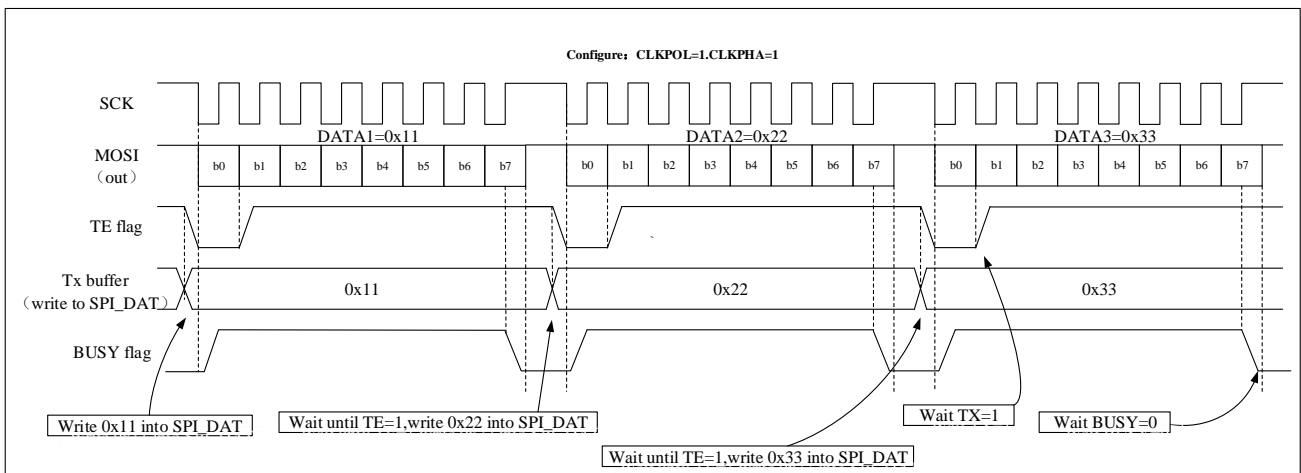

### 21.3.3 Status flag

The SPI\_STS register has 3 flag bits to monitor the status of the SPI:

#### Send buffer empty flag bit (TE)

When the send buffer is empty, the TE flag (SPI\_STS.TE) is set to 1, which means that new data can be written into the SPI\_DAT register. When the send buffer is not empty, the hardware will clear this flag to 0.

#### Receive buffer non-empty flag bit (RNE)

When the receive buffer is not empty, the RNE flag (SPI\_STS.RNE) is set to 1, so the user knows that there is data in the receive buffer. After reading the SPI\_DAT register, the hardware will set this flag to 0.

#### BUSY flag bit (BUSY)

When the transmission starts, the hardware sets the BUSY flag (SPI\_STS.BUSY) to 1, and after the transmission ends, the hardware sets the BUSY flag to 0.

Only when the device is in the master one-wire bidirectional receive mode, the BUSY flag (SPI\_STS.BUSY) will be set to 0 when the communication is in progress.

The BUSY flag (SPI\_STS.BUSY) will be cleared to 0 in the following cases:

- End of transmission (except for continuous communication in master mode);
- Turn off the SPI module (SPI\_CTRL1.SPIEN = 0);
- The master mode error occurs (SPI\_STS.MODERR = 1)

When the communication is discontinuous: the BUSY flag (SPI\_STS.BUSY) is cleared to '0' between the transmission of each data item.

When communication is continuous: in master mode, the BUSY flag (SPI\_STS.BUSY) remains high during the entire transfer process; In slave mode, the BUSY flag (SPI\_STS.BUSY) will be low for 1 SPI clock cycle between each data item transfer. So do not use the BUSY flag to handle the sending and receiving of each data item.

### 21.3.4 Disabling the SPI

In order to turn off the SPI module, different operation modes require different operation steps:

#### Master or slave full duplex mode

1. Wait for the RNE flag (SPI\_STS.RNE) to be set to 1 and the last byte to be received;
2. Wait for the TE flag (SPI\_STS.TE) to be set to 1;
3. Wait for the BUSY flag (SPI\_STS.BUSY) to be cleared to 0;
4. Turn off the SPI module (SPI\_CTRL1.SPIEN = 0).

#### Two-wire one-way send-only mode or one-wire bidirectional send mode for master or slave

1. After writing the last byte to the SPI\_DAT register, wait for the TE flag (SPI\_STS.TE) to be set to 1;
2. Wait for the BUSY flag (SPI\_STS.BUSY) to be cleared to 0;
3. Turn off the SPI module (SPI\_CTRL1.SPIEN = 0).

#### Two-wire one-way receive-only mode or one-wire bidirectional receive mode for master

1. Wait for the penultimate RNE (SPI\_STS.RNE) to be set to 1;
2. Before closing the SPI module (SPI\_CTRL1.SPIEN = 0), wait for 1 SPI clock cycle (using software delay);
3. Wait for the last RNE (SPI\_STS.RNE) to be set before entering shutdown mode (or turning off the SPI module clock).

#### Two-wire one-way receive-only mode or one-wire bidirectional receive mode for slave

1. The SPI module can be turned off at any time (SPI\_CTRL1.SPIEN = 0), and after the current transfer is over, the SPI module will be turned off;
2. If you want to enter the shutdown mode, you must wait for the BUSY flag (SPI\_STS.BUSY) to be set to 0 before entering the shutdown mode (or turn off the SPI module clock).

### 21.3.5 SPI communication using DMA

Users can choose DMA for SPI data transfer, the application program can be released, and the system efficiency can be greatly improved.

When the send buffer DMA is enabled ( $SPI\_CTRL2.TDMAEN = 1$ ), each time the TE flag ( $SPI\_STS.TE$ ) bit is 1, a DMA request will be generated, and the DMA will automatically write the data to the  $SPI\_DAT$  register, which will clear the TE flag ( $SPI\_STS.TE$ ) bit. When the receive buffer DMA is enabled ( $SPI\_CTRL2.RDMAEN = 1$ ), each time the RNE flag ( $SPI\_STS.RNE$ ) bit is set to 1, a DMA request will be generated, and the DMA will automatically read the  $SPI\_DAT$  register, which will clear the RNE flag ( $SPI\_STS.RNE$ ) bit.

When the SPI is only used for sending data, only the send DMA channel of the SPI needs to be enabled ( $SPI\_CTRL2.TDMAEN = 1$ ).

When the SPI is only used for receiving data, only the receive DMA channel of the SPI needs to be enabled ( $SPI\_CTRL2.RDMAEN = 1$ ).

In send mode, after DMA has sent all the data to be sent ( $DMA\_INTSTS.TXCF = 1$ ), BUSY flag ( $SPI\_STS.BUSY$ ) can monitor to confirm whether SPI communication is over, which can avoid destroying the transmission of the last data when the SPI is turned off or enters the shutdown mode. Therefore, the software needs to wait for the TE flag ( $SPI\_STS.TE$ ) bit to be set to 1, and wait for the BUSY flag ( $SPI\_STS.BUSY$ ) bit to be set to 0.

Figure 21-11 Transmission using DMA

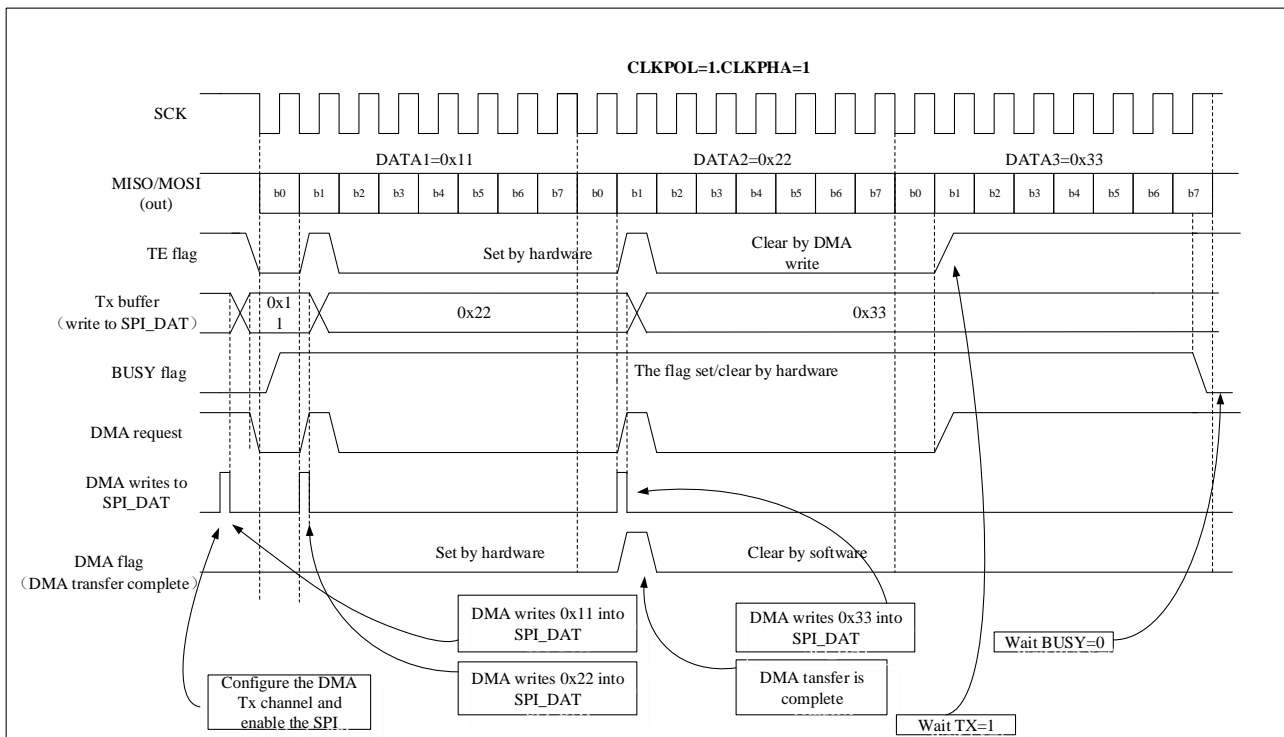
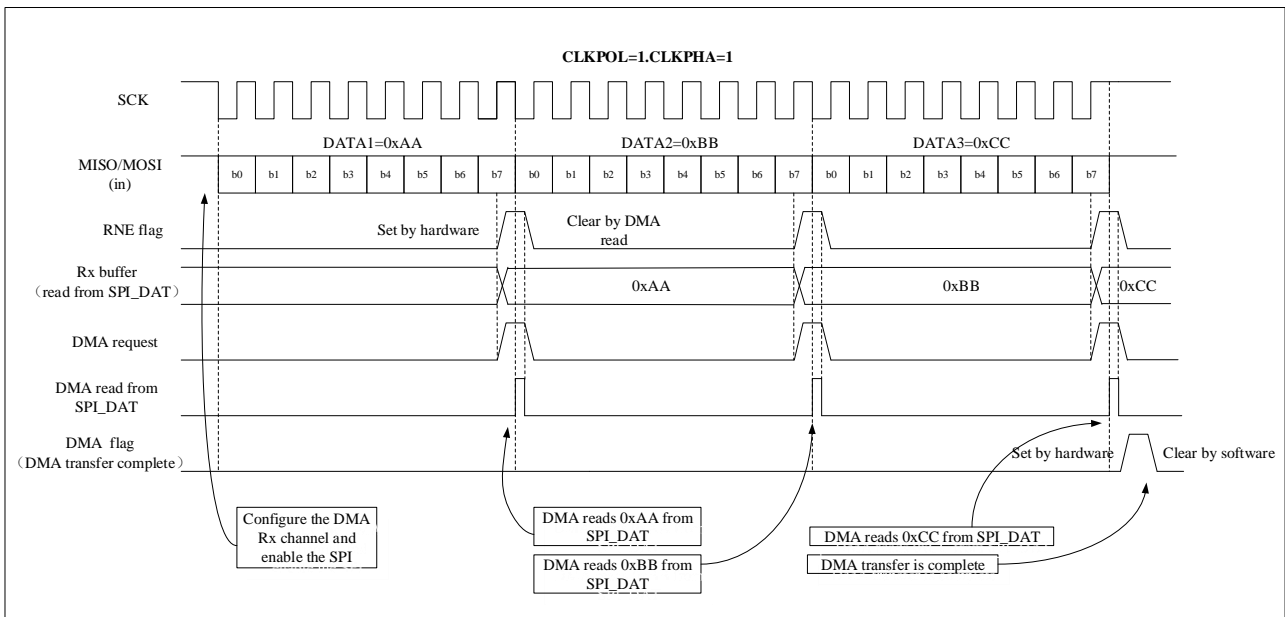

Figure 21-12 Reception using DMA



### 21.3.6 CRC calculation

SPI contains two independent CRC calculators for data sending and data receiving to ensure the correctness of data transmission. According to the sending and receiving data frame format, CRC adopts different calculation methods, the 8-bit data frame format adopts CRC8, and the 16-bit data frame format adopts CRC16. The polynomial used in the SPI CRC calculation is set by the SPI\_CRCPOLY register, and the user enables the CRC calculation by setting the SPI\_CTRL1.CRCEN = 1.

In send mode, after the last data is written into the send buffer, set the SPI\_CTRL1.CRCNEXT = 1, which indicates that the hardware will start sending the CRC value (SPI\_CRCTDAT value) after sending the data. When the CRC is sent, the CRC calculation will stop.

In receive mode, after the penultimate data frame is received, set the SPI\_CTRL1.CRCNEXT = 1. The received CRC and SPI\_CRCDAT values are compared, if they are different, the SPI\_STS.CRCERR bit is set to 1. If the SPI\_CTRL2.ERRINTEN bit is set to 1, an interrupt will be generated.

In order to keep the synchronization of the next CRC calculation result of the master-slave device, the user should clear the CRC value of the master-slave device. Setting the SPI\_CTRL1.CRCEN bit resets the SPI\_CRCDAT and SPI\_CRCTDAT registers. Take the following steps in order: SPI\_CTRL1.SPIEN = 0; SPI\_CTRL1.CRCEN = 0; SPI\_CTRL1.CRCEN = 1; SPI\_CTRL1.SPIEN = 1.

Most importantly, when the SPI is configured in slave mode and CRC is enabled, as long as there is a clock pulse on SCLK pin, the CRC calculation will still be performed even if the NSS pin is high. This situation is common when the master device communicates with multiple slave devices alternately, so it is necessary to avoid CRC misoperation.

When the SPI hardware CRC check is enabled (SPI\_CTRL1.CRCEN = 1) and the DMA is enabled, the hardware automatically completes the sending and receiving of CRC bytes when the communication ends.

### 21.3.7 Error flag

#### Master mode failure error (MODERR)

The following two conditions will cause the master mode failure error:

- NSS pin hardware management mode, the master device NSS pin is pulled low;
- NSS pin software management mode, the SPI\_CTRL1.SSEL bit is set to 0.

When a master mode failure error occurs, the SPI\_STS.MODERR bit is set to 1. An interrupt is generated if the user enables the corresponding interrupt (SPI\_CTRL2.ERRINTEN = 1). The SPI\_CTRL1.SPIEN bit and SPI\_CTRL1.MSEL bit will be write protected and both are cleared by hardware. SPI is turned off and forced into slave mode

Software performs a read or write operation to the SPI\_STS register, and then writes to the SPI\_CTRL1 register to clear the SPI\_STS.MODERR bit (in multi-master mode, the master's NSS pin must be pulled high first).

Normally, the SPI\_STS.MODERR bit of the slave cannot be set to 1. However, in a multi-master configuration, the slave's SPI\_STS.MODERR bit may be set to 1. In this case, the SPI\_STS.MODERR bit indicates that there is a multi-master collision. The interrupt routine can perform a reset or return to the default state to recover from an error state.

### Overflow error (OVER)

When the SPI\_STS.RNE bit is set to 1, but there is still data sent into the receive buffer, an overflow error will occur. At this time, the overflow flag SPI\_STS.OVER bit is set to 1. An interrupt is generated if the user enables the corresponding interrupt (SPI\_CTRL2.ERRINTEN = 1). All received data is lost, and the SPI\_DAT register retains only previously unread data.

Read the SPI\_DAT register and the SPI\_STS register in turn to clear the SPI\_STS.OVER bit.

### CRC error (CRCERR)

The CRC error flag is used to check the validity of the received data. A CRC error occurs when the received CRC value does not match the SPI\_CRCRDAT value. At this time, the SPI\_STS.CRCERR flag bit is set to '1', and an interrupt will be generated if the user enables the corresponding interrupt (SPI\_CTRL2.ERRINTEN = 1).

## 21.3.8 SPI interrupt

Table 21-1 SPI interrupt request

| Interrupt event               | Event flag bit | Enable control bit |
|-------------------------------|----------------|--------------------|
| Send buffer empty flag        | TE             | TEINTEN            |
| Receive buffer non empty flag | RNE            | RNEINTEN           |
| Master mode failure event     | MODERR         | ERRINTEN           |
| Overflow error                | OVER           |                    |
| CRC error flag                | CRCERR         |                    |

## 21.4 I<sup>2</sup>S function description

The block diagram of I<sup>2</sup>S is shown in the figure below:

Figure 21-13 I<sup>2</sup>S block diagram

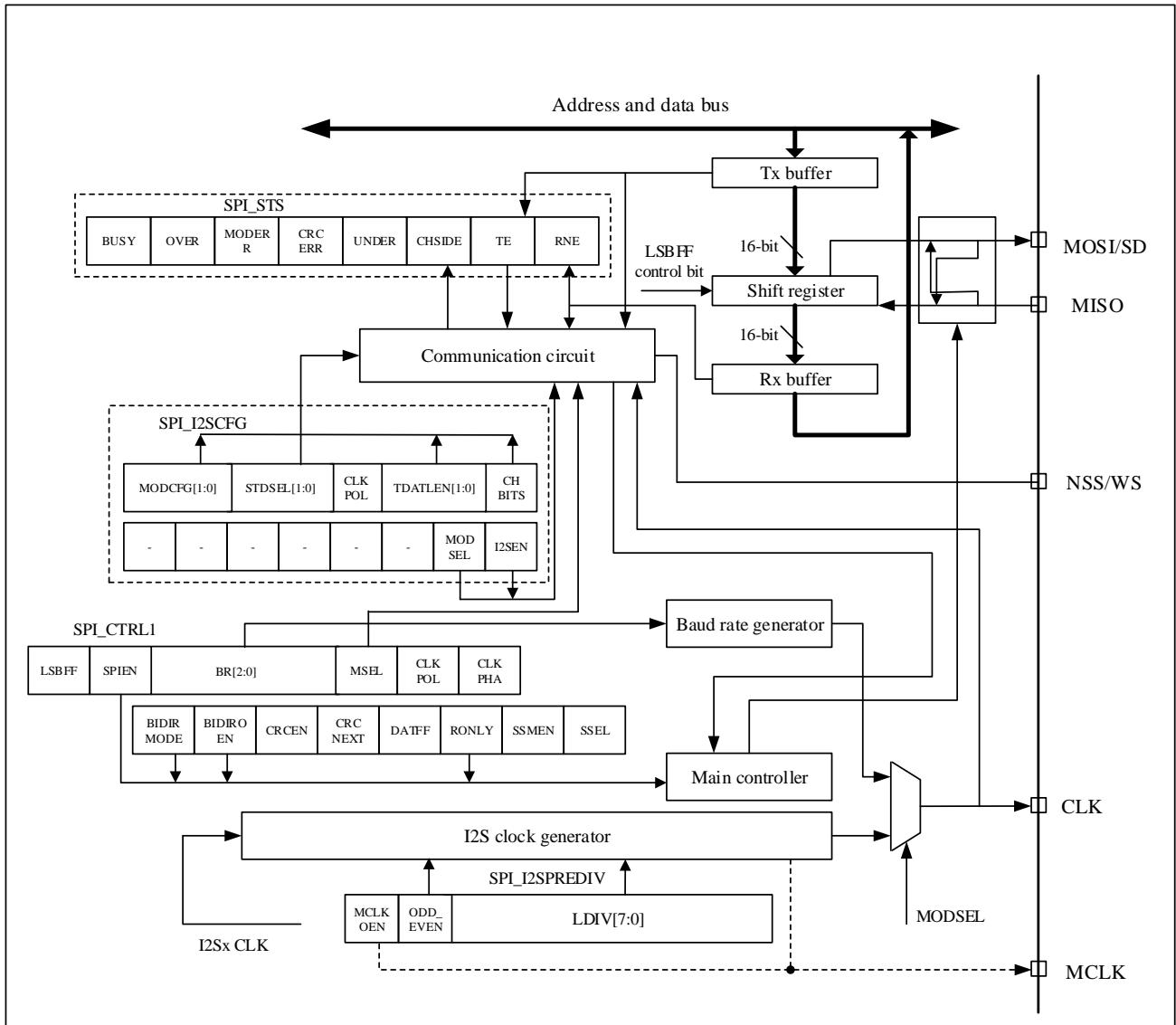

The I<sup>2</sup>S interface uses the same pins, flags and interrupts as the SPI interface. Setting the `SPL_I2SCFG.MODSEL = 1` selects the I<sup>2</sup>S audio interface.

I<sup>2</sup>S has a total of 4 pins, 3 of which are shared with SPI:

- **CLK:** Serial clock (shared with SCLK pin), CLK generates a pulse every time 1-bit audio data is sent.
- **SD:** Serial data (shared with MOSI pin), used for data send and receive;
- **WS:** Channel selection (shared with NSS pin), used as data control signal output in master mode, and used as input in slave mode;
- **MCLK:** master clock (independent mapping, optional), output  $256 \times F_s$  clock signal to ensure better synchronization between systems.

Note:  $F_s$  is the sampling frequency of audio signal

In master mode, I2S uses its own clock generator to generate clock signals for communication, and this clock generator is also the clock source of the master clock output (SPI\_I2SPREDIV.MCLKOEN = 1, the master clock output is enabled).

### 21.4.1 Supported audio protocols

Four audio standards can be selected by setting the SPI\_I2SCFG.STDSEL[1:0] bits:

- I<sup>2</sup>S Philips standard
- MSB alignment standard
- LSB alignment standard
- PCM standard

The audio data of the left channel and the right channel are usually time-division multiplexed, and the left channel always sends data before the right channel. By checking the SPI\_STS.CHSIDE bit, the user can distinguish which channel the received data belongs to. However, in the PCM audio standard, the CHSIDE bit has no meaning.

By setting the SPI\_I2SCFG.TDATLEN bits, the user can set the length of the data to be transmitted, and set the data bit width of the channel by setting the SPI\_I2SCFG.CHBITS bits. There are 4 data formats for sending data as follows:

- 16-bit data is packed into 16-bit data frame
- 16-bit data is packed into a 32-bit data frame (the first 16 bits are meaningful data, and the last 16 bits are set to 0 by hardware)
- 24-bit data is packed into 32-bit data frame (the first 24-bit data is meaningful data, and the latter 8-bit data is set to 0 by hardware)
- 32-bit data is packed into 32-bit data frame

I2S uses the same SPI\_DAT register as SPI to send and receive 16-bit wide data. If I2S needs to send or receive 24-bit or 32-bit wide data, the CPU needs to read or write the SPI\_DAT register twice. On the other hand, when I2S sends or receives 16-bit wide data, the CPU only needs to read or write the SPI\_DAT register once.

Regardless of which data format and communication standard is used, I2S always sends the data high-order bit (MSB) first.

#### I<sup>2</sup>S Philips standard

Using the I2S Philips standard, the device that sends data changes the data on the falling edge of the clock, and the device that receives data samples the data on the rising edge of the clock. The WS signal should be valid one clock before the first data bit (MSB) is sent and will change on the falling edge of the clock signal.

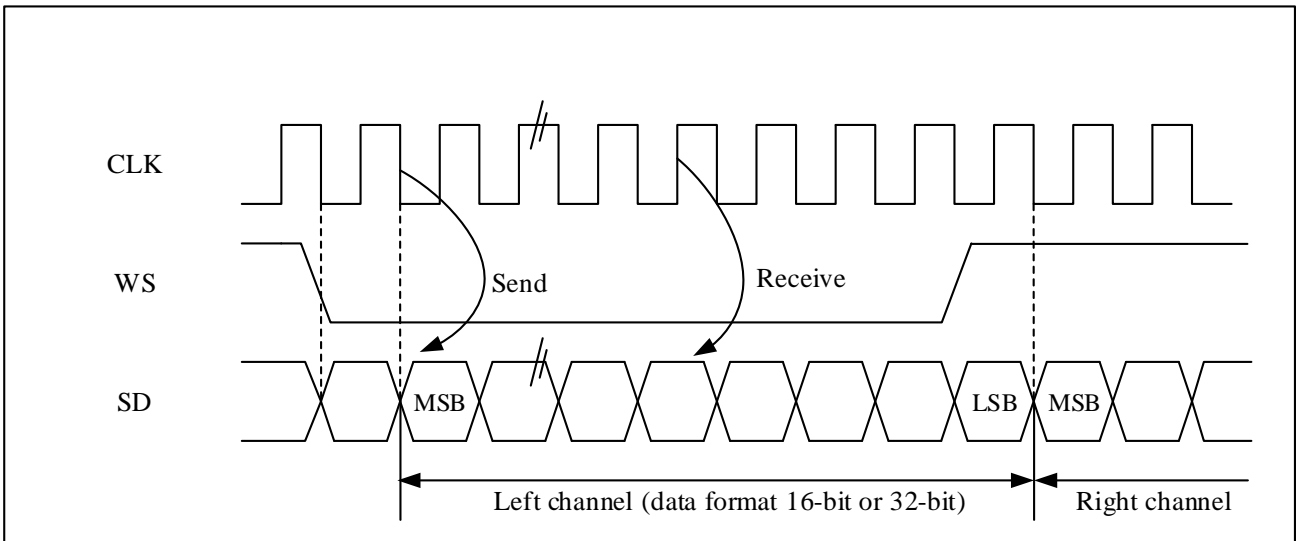
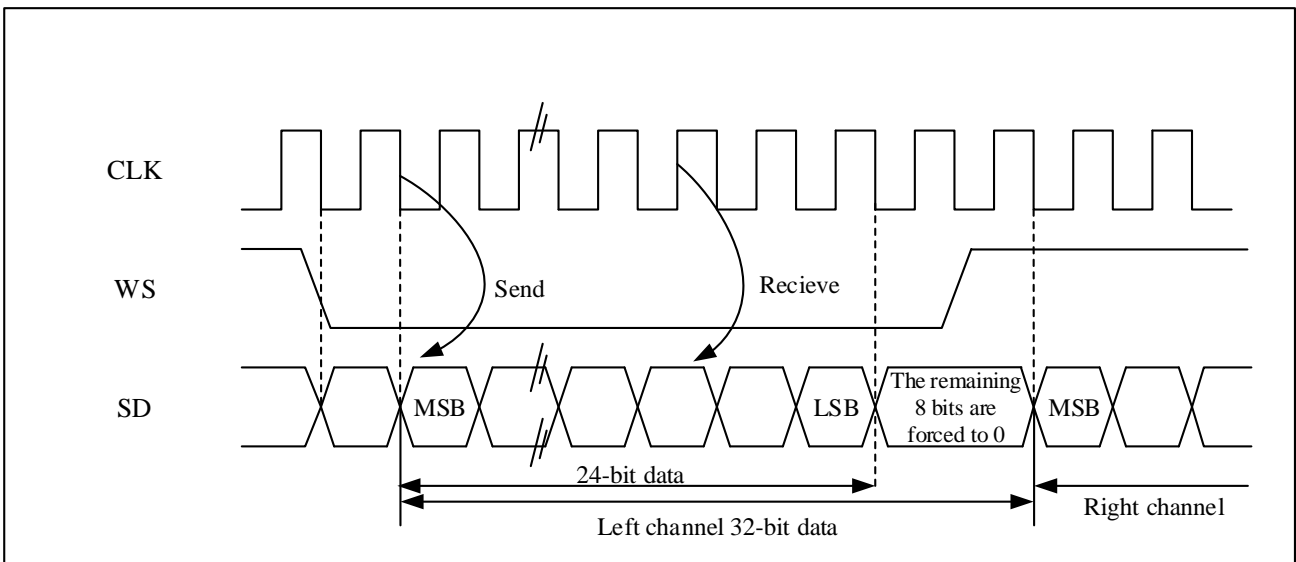
Figure 21-14 I<sup>2</sup>S Philips protocol waveform (16/32-bit full precision, CLKPOL = 0)

 Figure 21-15 I<sup>2</sup>S Philips protocol standard waveform (24-bit frame, CLKPOL = 0)

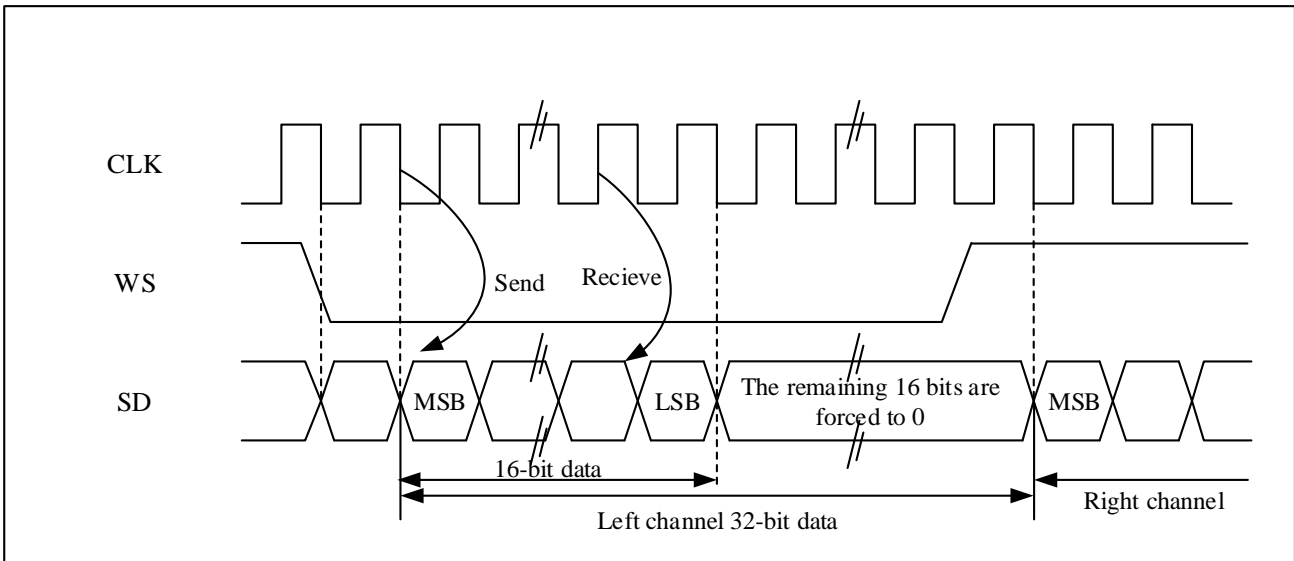
If the 24-bit data needs to be packaged into 32-bit data frame format, the CPU needs to read or write the SPI\_DAT register twice during each frame of data transmission. For example, if the user sends 24-bit data 0x95AA66, the CPU will first write 0x95AA into the SPI\_DAT register, and then write 0x66XX into the SPI\_DAT register (only the upper 8-bit data is valid, the lower 8-bit data is meaningless and can be any value); if the user receives 24-bit data 0x95AA66, the CPU will first read the SPI\_DAT register to get 0x95AA, and then read the SPI\_DAT register to get 0x6600 (only the upper 8-bit data is valid, and the lower 8-bit data is always 0).

Figure 21-16 I<sup>2</sup>S Philips protocol standard waveform (16-bit extended to 32-bit packet frame, CLKPOL = 0)

If 16-bit data needs to be packed into 32-bit data frame format, the CPU only needs to read or write the SPI\_DAT register once for each frame of data transmission. The lower 16 bits of data for expansion to 32 bits are always set to 0x0000. For example, if the user sends or receives 16-bit data 0x89C1 (extended to 32-bit data is 0x89C10000). In the process of sending data, the upper 16-bit half word (0x89C1) needs to be written into the SPI\_DAT register; the user can write new data until the SPI\_STS.TE bit is set. An interrupt is generated if the user enables the corresponding interrupt. The sending is performed by hardware, even if the last 16 bits (0x0000) are not sent, the hardware will set the TE (SPI\_STS.TE) bit to 1 and the corresponding interrupt will be generated. In the process of receiving data, the RNE flag (SPI\_STS.RNE) will be set to 1 after each time the device receives the upper 16-bit halfword (0x89C1). An interrupt is generated if the user enables the corresponding interrupt. In this way, there is more time between 2 reads and writes, which can prevent underflow or overflow from happening.

### MSB alignment standard

In the MSB alignment standard, the device sending the data will change the data on the falling edge of the clock, and the device receiving the data will sample the data on the rising edge of the clock. The WS signal and the first data bit (MSB) are generated simultaneously.

The standard data receiving and sending processing mode is the same as I<sup>2</sup>S Philips standard.

Figure 21-17 The MSB is aligned with 16-bit or 32-bit full precision, CLKPOL = 0.

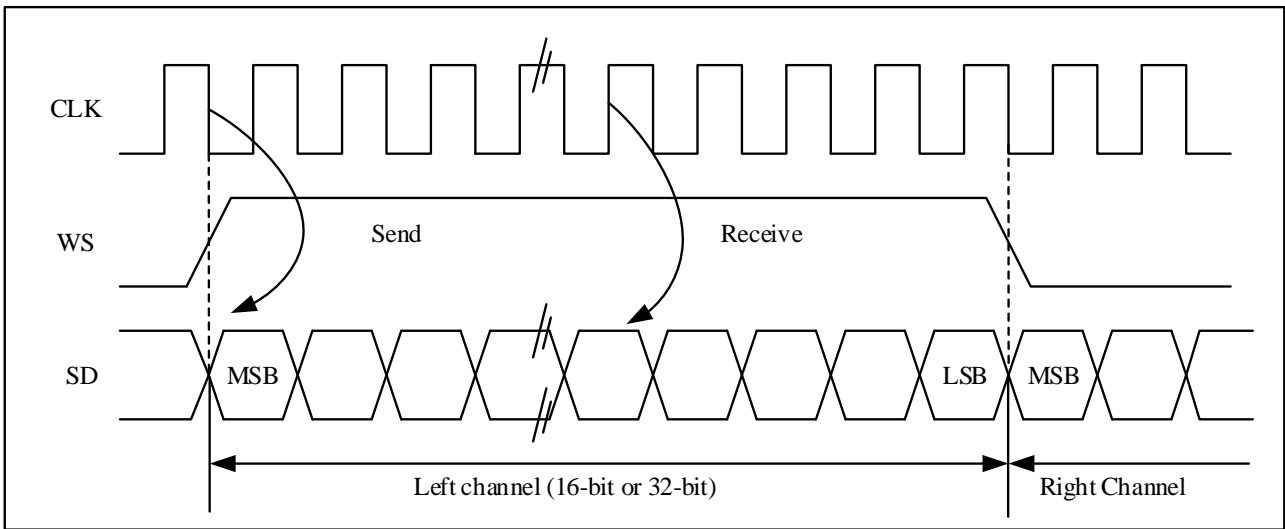

Figure 21-18 MSB aligns 24-bit data, CLKPOL = 0

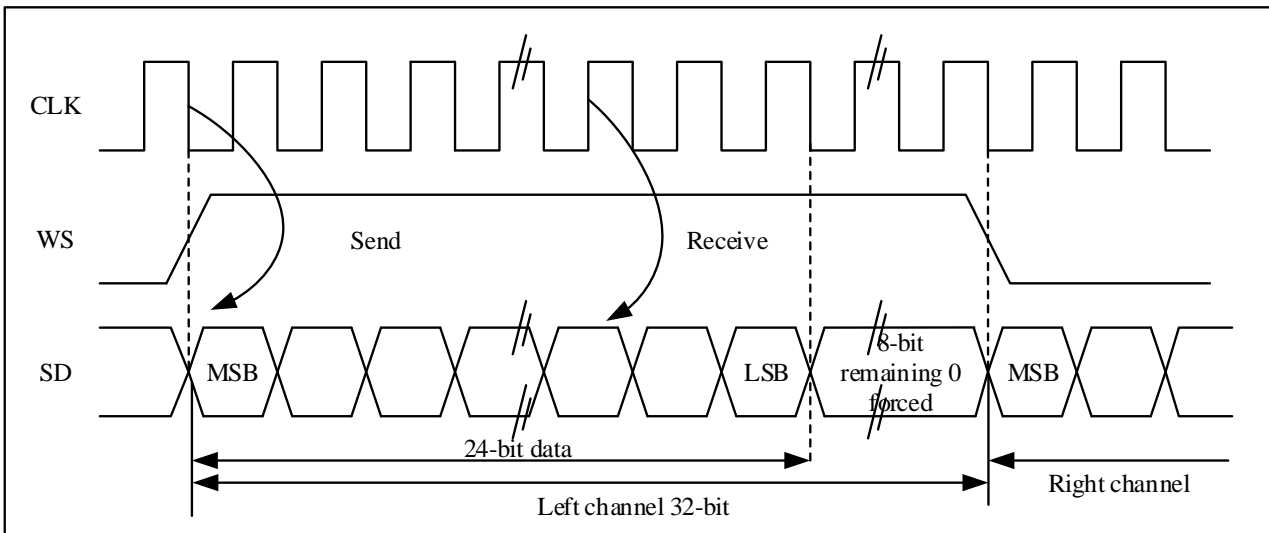
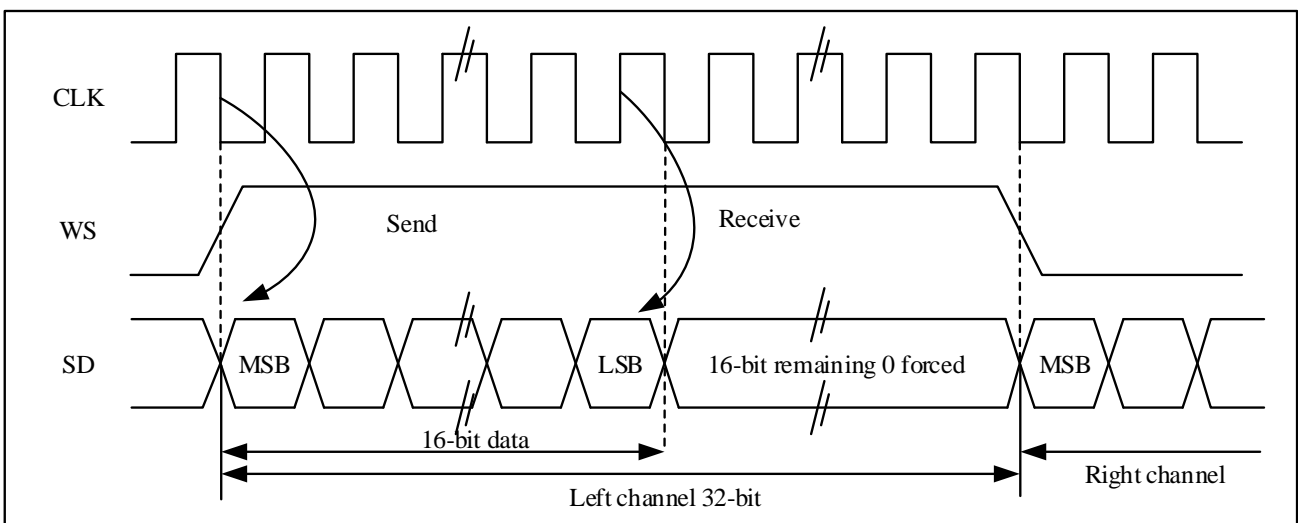

Figure 21-19 MSB-aligned 16-bit data is extended to 32-bit packet frame, CLKPOL = 0



## LSB alignment standard

In 16-bit or 32-bit full-precision frame format, LSB alignment standard is the same as MSB alignment standard.

Figure 21-20 LSB alignment 16-bit or 32-bit full precision, CLKPOL = 0

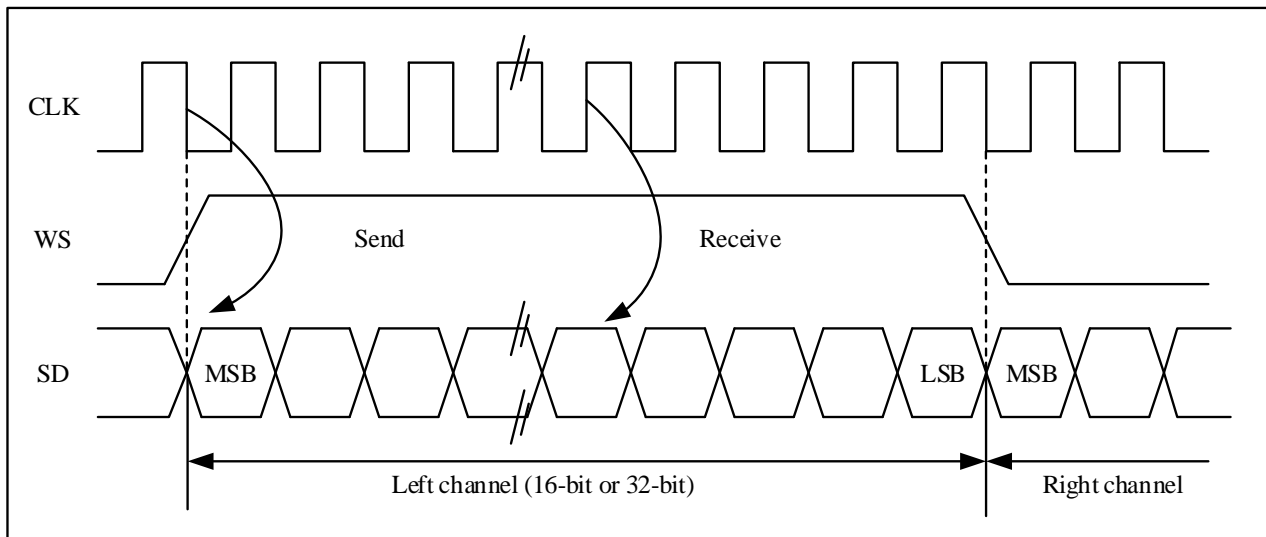
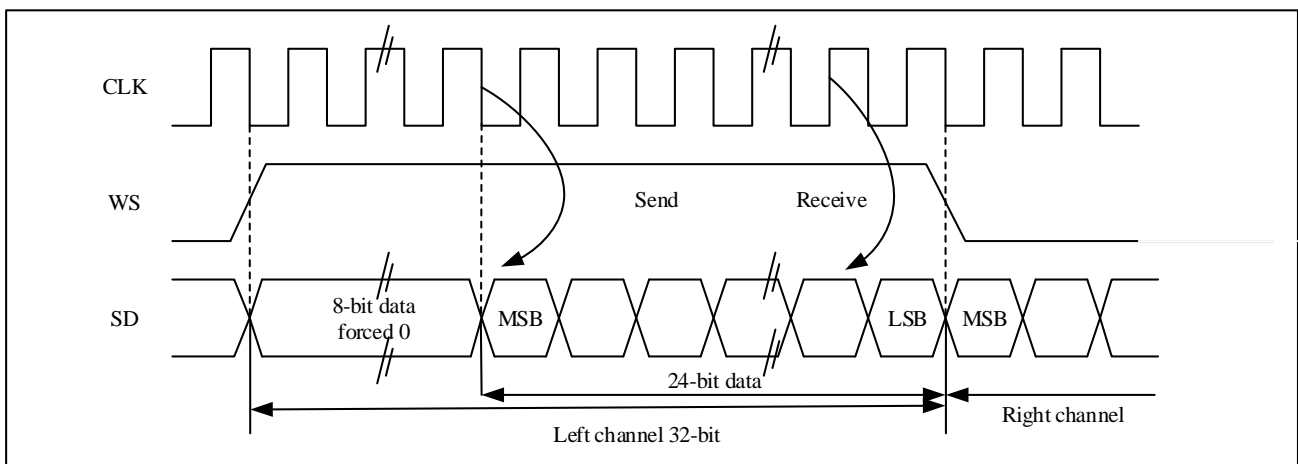
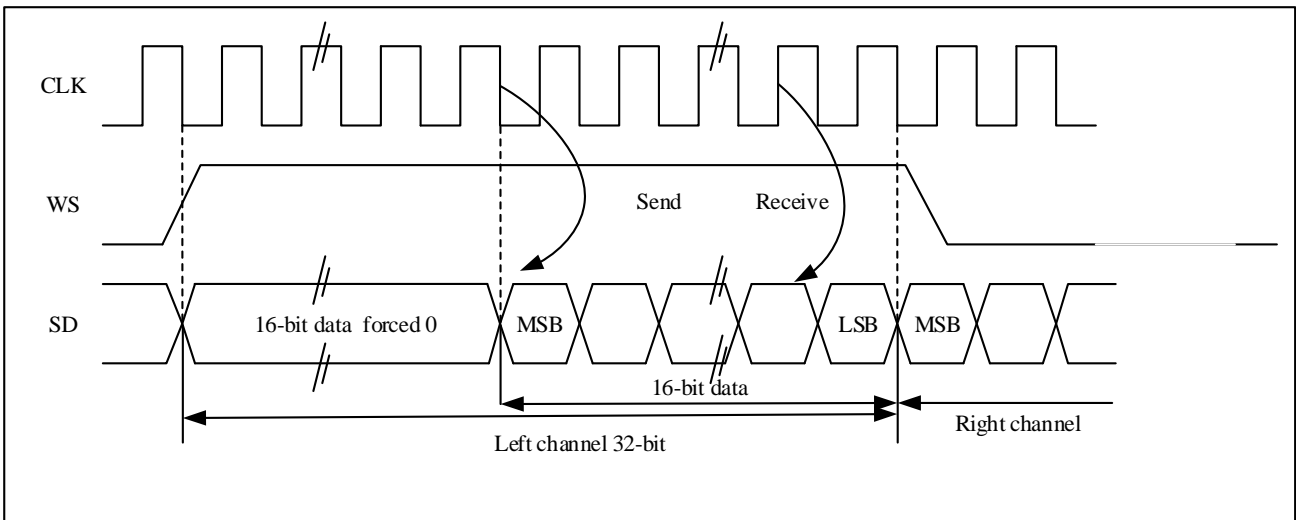

Figure 21-21 LSB aligns 24-bit data, CLKPOL = 0



If the 24-bit data needs to be packed into the 32-bit data frame format, the CPU needs to read or write the SPI\_DAT register twice during each frame of data transmission. For example, if the user sends 24-bit data 0x95AA66, the CPU will first write 0xXX95 (only the lower 8-bit data is valid, the upper 8-bit data is meaningless and can be any value) into the SPI\_DAT register, and then write 0xAA66 into the SPI\_DAT register. If the user receives 24-bit data 0x95AA66, the CPU will first read the SPI\_DAT register to get 0x0095 (only the lower 8 bits are valid, the upper 8 bits are always 0), and then read the SPI\_DAT register to get 0xAA66.

Figure 21-22 LSB aligned 16-bit data is extended to 32-bit packet frame, CLKPOL = 0



If the 16-bit data needs to be packaged into a 32-bit data frame format, the CPU only needs to read or write the SPI\_DAT register once for each frame of data transmission. The upper 16 bits of extended to 32 bits data are set to 0x0000 by hardware, if the user sends or receives 16-bit data 0x89C1 (extended to 32-bit data is 0x000089C1). In the process of sending data, the upper 16-bit halfword (0x0000) needs to be written to the SPI\_DAT register first; once the valid data starts to be send, the next TE (SPI\_STS.TE) event will be generated. In the process of receiving data, once the device receives valid data, the RNE (SPI\_STS.RNE) event will be generated. In this way, there is more time between 2 reads and writes, which can prevent underflow or overflow from happening.

### PCM standard

In the PCM standard, there are two frame structures, short frame and long frame. The user can select the frame structure by setting the SPI\_I2SCFG.PCMFSYNC bits. The WS signal indicates frame synchronization information. The WS signal for synchronizing long frames is 13 bits effective; the WS signal length for synchronizing short frames is 1 bit.

The standard data receiving and sending processing mode is the same as I<sup>2</sup>S Philips standard.

Figure 21-23 PCM standard waveform (16 bits)

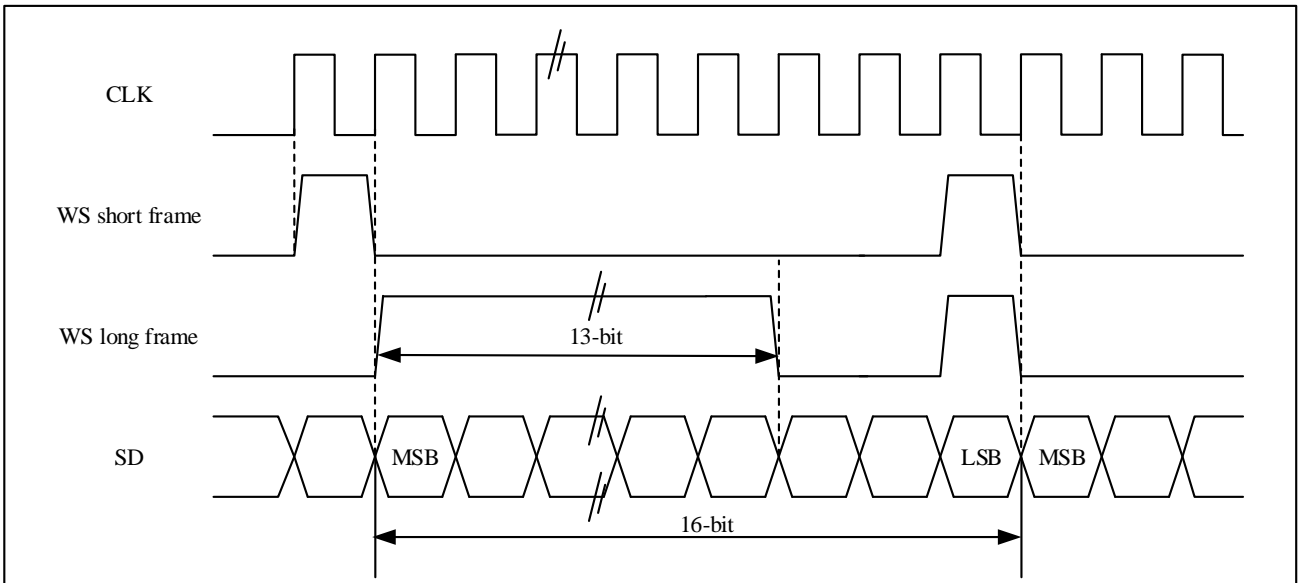
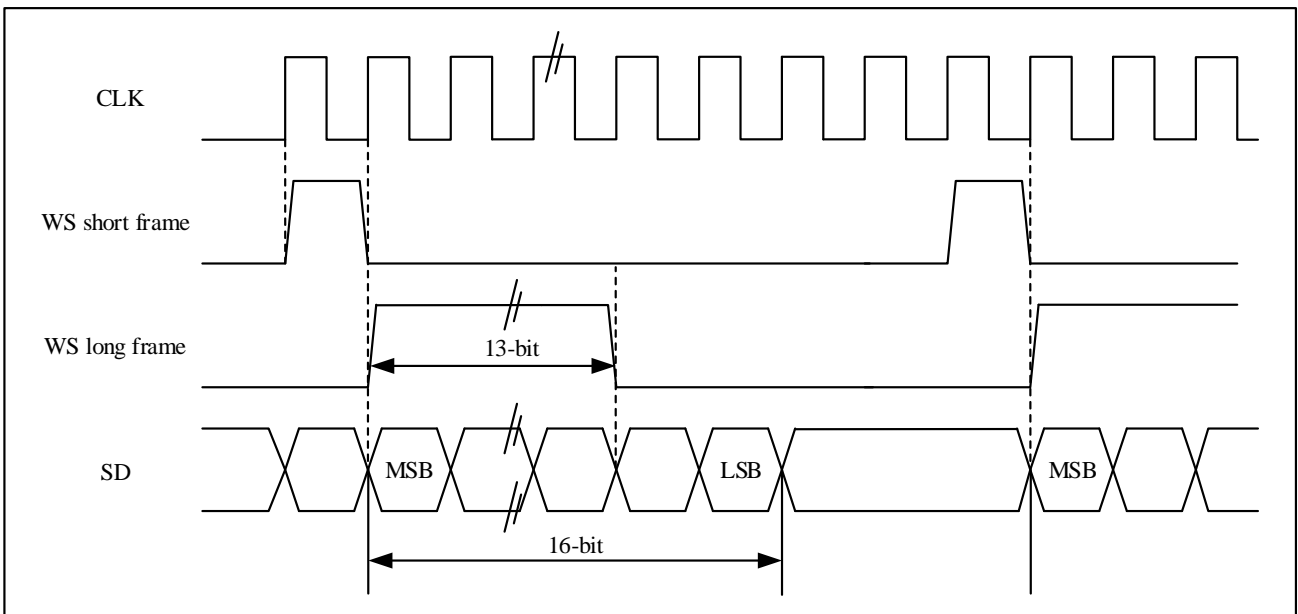
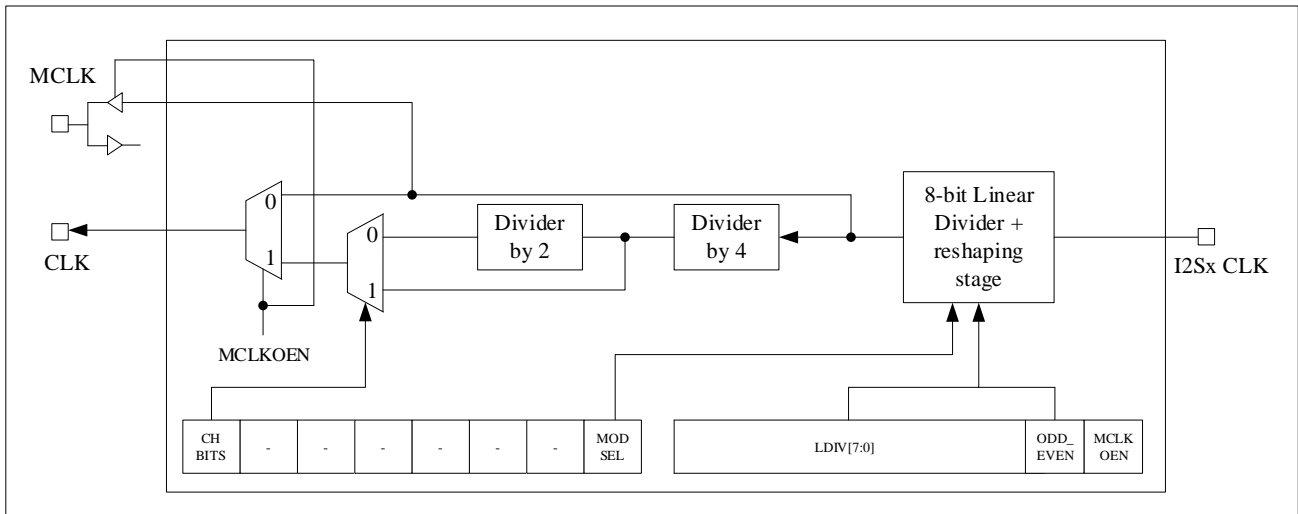

Figure 21-24 PCM standard waveform (16-bit extended to 32-bit packet frame)



## 21.4.2 Clock generator

In the master mode, the linear divider needs to be set correctly in order to obtain the desired audio frequency.

Figure 21-25 I<sup>2</sup>S clock generator structure

Note: The clock source of I<sup>2</sup>Sx CLK is HSI, HSE or PLL system clock that drives AHB clock.

The bit rate of I<sup>2</sup>S determines the data flow on the I<sup>2</sup>S data line and the frequency of the I<sup>2</sup>S clock signal.

$$\text{I}^2\text{S bit rate} = \text{number of bits per channel} \times \text{number of channels} \times \text{audio sampling frequency}$$

For a signal with left and right channels and 16-bit audio, the I<sup>2</sup>S bit rate is calculated as:

$$\text{I}^2\text{S bit rate} = 16 \times 2 \times F_s$$

If the packet length is 32 bits, there are:

$$\text{I}^2\text{S bit rate} = 32 \times 2 \times F_s$$

Figure 21-26 Audio sampling frequency definition

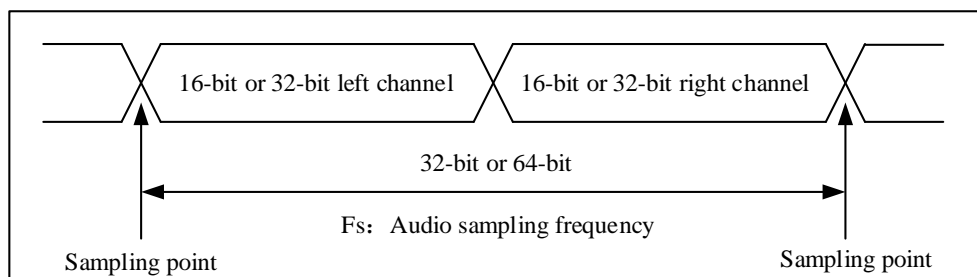

The sampling signal frequency of the audio can be set by setting the SPI\_I2SPREDIV.ODD\_EVEN bit and the SPI\_I2SPREDIV.LDIV[7:0] bits. Audio can be sampled at 96kHz, 48kHz, 44.1kHz, 32kHz, 22.05kHz, 16kHz, 11.025kHz, or 8kHz (or any value within this range). Set the linear divider according to the following formula:

$$\text{When MCLKOEN} = 1 \text{ and CHBITS} = 0, F_s = I^2Sx \text{ CLK} / [(16 \times 2) \times ((2 \times LDIV) + ODD\_EVEN) \times 8]$$

$$\text{When MCLKOEN} = 1 \text{ and CHBITS} = 1, F_s = I^2Sx \text{ CLK} / [(32 \times 2) \times ((2 \times LDIV) + ODD\_EVEN) \times 4]$$

$$\text{When MCLKOEN} = 0 \text{ and CHBITS} = 0, F_s = I^2Sx \text{ CLK} / [(16 \times 2) \times ((2 \times LDIV) + ODD\_EVEN)]$$

$$\text{When MCLKOEN} = 0 \text{ and CHBITS} = 1, F_s = I^2Sx \text{ CLK} / [(32 \times 2) \times ((2 \times LDIV) + ODD\_EVEN)]$$

The exact audio frequency can be obtained by referring to the clock configuration in the table below.

Table 21-2 Use the standard 8MHz HSE clock to get accurate audio frequency.

| SYSCLK<br>(MHz) | I <sup>2</sup> S_LDIV |         | I <sup>2</sup> S_ODD_EVEN |         | MCLK    | Target<br>Fs(Hz) | Real Fs(Hz) |          | Error   |         |
|-----------------|-----------------------|---------|---------------------------|---------|---------|------------------|-------------|----------|---------|---------|
|                 | 16 bits               | 32 bits | 16 bits                   | 32 bits |         |                  | 16 bits     | 32 bits  | 16 bits | 32 bits |
| 72              | 11                    | 6       | 1                         | 0       | without | 96000            | 97826.09    | 93750    | 1.90%   | 2.34%   |
| 72              | 23                    | 11      | 1                         | 1       | without | 48000            | 47872.34    | 48913.04 | 0.27%   | 1.90%   |
| 72              | 25                    | 13      | 1                         | 0       | without | 44100            | 44117.65    | 43269.23 | 0.04%   | 1.88%   |
| 72              | 35                    | 17      | 0                         | 1       | without | 32000            | 32142.86    | 32142.86 | 0.44%   | 0.44%   |
| 72              | 51                    | 25      | 0                         | 1       | without | 22050            | 22058.82    | 22058.82 | 0.04%   | 0.04%   |
| 72              | 70                    | 35      | 1                         | 0       | without | 16000            | 15675.75    | 16071.43 | 0.27%   | 0.45%   |
| 72              | 102                   | 51      | 0                         | 0       | without | 11025            | 11029.41    | 11029.41 | 0.04%   | 0.04%   |
| 72              | 140                   | 70      | 1                         | 1       | without | 8000             | 8007.11     | 7978.72  | 0.09%   | 0.27%   |
| 72              | 2                     | 2       | 0                         | 0       | yes     | 96000            | 70312.15    | 70312.15 | 26.76%  | 26.76%  |
| 72              | 3                     | 3       | 0                         | 0       | yes     | 48000            | 46875       | 46875    | 2.34%   | 2.34%   |
| 72              | 3                     | 3       | 0                         | 0       | yes     | 44100            | 46875       | 46875    | 6.29%   | 6.29%   |
| 72              | 4                     | 4       | 1                         | 1       | yes     | 32000            | 31250       | 31250    | 2.34%   | 2.34%   |
| 72              | 6                     | 6       | 1                         | 1       | yes     | 22050            | 21634.61    | 21634.61 | 1.88%   | 1.88%   |
| 72              | 9                     | 9       | 0                         | 0       | yes     | 16000            | 15625       | 15625    | 2.34%   | 2.34%   |
| 72              | 13                    | 13      | 0                         | 0       | yes     | 11025            | 10817.3     | 10817.3  | 1.88%   | 1.88%   |
| 72              | 17                    | 17      | 1                         | 1       | yes     | 8000             | 8035.71     | 8035.71  | 0.45%   | 0.45%   |

### 21.4.3 I<sup>2</sup>S Transmission and reception sequence

#### I<sup>2</sup>S initialization sequence

1. The user can set the SPI\_I2SPREDIV.LDIV [7:0] bits and SPI\_I2SPREDIV.ODD\_EVEN bit to configure the related prescaler and serial clock baud rate;
2. If the user needs the master device to provide the main clock MCLK to the external DAC/ADC audio device, set the SPI\_I2SPREDIV.MCLKOEN = 1. (Calculate LDIV and ODD\_EVEN according to different clock outputs, see section 21.4.2).
3. The user can set the SPI\_I2SCFG.CLKPOL bit to define the polarity of the communication clock when idle; the user can set the SPI\_I2SCFG.MODSEL = 1 to configure the device to be in I2S mode, and set SPI\_I2SCFG.MODCFG[1:0] bits to select the I2S master-slave mode and transmission direction (send or receive); set SPI\_I2SCFG.STDSEL[1:0] bits to select the corresponding I2S standard (under the PCM standard, set the SPI\_I2SCFG.PCMFSYNC bit to select the PCM frame synchronization mode); set SPI\_I2SCFG.TDATLEN [1:0] bits to select length of data to be transmitted, and select the number of data bits of per channel by set the SPI\_I2SCFG.CHBITS bit;
4. When user needs to enable interrupt or DMA, the configuration operation is the same as SPI;
5. Finally, set the SPI\_I2SCFG.I2SEN = 1 to start I2S communication.

#### Sending sequence

##### Master mode

When I2S works in master mode, the CLK pin outputs the serial clock, the WS pin generates the channel selection signal, and set the SPI\_I2SPREDIV.MCLKOEN bit to select whether to output the master clock (MCLK).

The sending process begins when data is written to the send buffer. When the data of the current channel is moved from the send buffer to the shift register in parallel, the flag bit TE (SPI\_STS.TE) is set to '1'. At this time, the data of the other channel should be written into SPI\_DAT. The channel corresponding to the current data to be transmitted is confirmed by the flag bit CHSIDE (SPI\_STS.CHSIDE). The value of CHSIDE (SPI\_STS.CHSIDE) is updated when TE (SPI\_STS.TE) is set to '1'. A complete data frame includes left and right channels, and only part of the data frame cannot be transmitted. When the flag bit TE (SPI\_STS.TE) is set to '1', if the SPI\_CTRL2.TEINTEN = 1, an interrupt will be generated.

The operation of writing data depends on the selected I2S standard. See chapter 21.4.1 for details.

When the user wants to turn off the I2S function, wait for the TE flag (SPI\_STS.TE) bit to be 1 and the BUSY flag (SPI\_STS.BUSY) bit to be 0, and then clear the SPI\_I2SCFG.I2SEN bit to 0.

### Slave mode

The sending process of the slave mode is similar to that of the master mode, the difference is as follows:

When I2S works in slave mode, there is no need to configure the clock, and the CLK pin and WS pin are connected to the corresponding pins of the master device. The sending process begins when an external master sends a clock signal, and when a WS signal requires data transfer. Only when the slave device is enabled and the data has been written to the I2S data register, the external master device can start communication.

When the first clock edge representing the next data transfer arrives, the new data has not been written into the SPI\_DAT register, an underflow occurs, and the SPI\_STS.UNDER flag bit is set to 1. If the SPI\_CTRL2.ERRINTEN bit is set to 1, an interrupt is generated to indicate that an error has occurred.

The SPI\_STS.CHSIDE flag indicates which channel the currently transmitted data corresponds to. Compared with the master mode sending process, in the slave mode, CHSIDE depends on the WS signal of the external master I2S device (WS signal is 1 means the left channel)

### Receiving sequence

#### Master mode

Audio is always received in 16-bit packets. According to the configured data and channel length, the received audio data will need to be transferred to the receive buffer once or twice.

When the data is transferred from the shift register to the receive buffer, the SPI\_STS.RNE flag bit is set to 1, at this time, the data is ready and can be read from the SPI\_DAT register. If the SPI\_CTRL2.RNEINTEN bit is set to 1, an interrupt will be generated. Reading the SPI\_DAT register to clear the SPI\_STS.RNE flag. If the previously received data is not read, new data is received again, an overflow occurs, and the SPI\_STS.OVER flag is set to 1. If the SPI\_CTRL2.ERRINTEN bit is set to 1, an interrupt is generated to indicate that an error has occurred.

The channel corresponding to the currently transmitted data can be confirmed by the SPI\_STS.CHSIDE bit. When the SPI\_STS.RNE flag bit is set to 1, the SPI\_STS.CHSIDE value is updated.

The operation of reading data depends on the selected I2S standard. See Section 21.4.1 for details.

When I2S function is turned off, different audio standards, data length and channel length adopt different operation steps:

- Data length is 16 bits, channel length is 32 bits (SPI\_I2SCFG.TDATLEN = 00, SPI\_I2SCFG.CHBITS = 1), LSB alignment standard (SPI\_I2SCFG.STDSEL = 10).

1. Wait for the penultimate RNE flag (SPI\_STS.RNE) bit to be set to '1'.
  2. Software delay, waiting for 17 I<sup>2</sup>S clock cycles.
  3. Turn off I<sup>2</sup>S (SPI\_I2SCFG.I2SEN = 0).
- The data length is 16 bits, the channel length is 32 bits (SPI\_I2SCFG.TDATLEN = 00 and SPI\_I2SCFG.CHBITS = 1), the MSB alignment standard (SPI\_I2SCFG.STDSEL = 01), I<sup>2</sup>S Philips standard (SPI\_I2SCFG.STDSEL = 00) or PCM standard (SPI\_I2SCFG.STDSEL = 11)
1. Wait for the last RNE flag (SPI\_STS.RNE) bit to be set to '1'.
  2. Software delay, waiting for 1 I<sup>2</sup>S clock cycle.
  3. Turn off I<sup>2</sup>S (SPI\_I2SCFG.I2SEN = 0).
- Other combinations of SPI\_I2SCFG.TDATLEN and SPI\_I2SCFG.CHBITS and any audio mode selected by SPI\_I2SCFG.STDSEL:
1. Wait for the penultimate RNE flag (SPI\_STS.RNE) bit to be set to '1'.
  2. Software delay, waiting for 1 I<sup>2</sup>S clock cycle.
  3. Turn off I<sup>2</sup>S (SPI\_I2SCFG.I2SEN = 0).

### Slave mode

The receiving process of the slave mode is similar to that of the master mode, with the following differences:

The CHSIDE flag (SPI\_STS.CHSIDE) indicates which channel corresponds to the currently transmitted data. Compared with the master mode receiving process, in the slave mode, SPI\_STS.CHSIDE depends on the WS signal of the external master device. When the I2S function is turned off, clear the SPI\_I2SCFG.I2SEN bit to 0 when the SPI\_STS.RNE flag is 1.

## 21.4.4 Status flag

There are the following 4 flag bits in the SPI\_STS register for monitoring the status of the I2S bus.

### TX buffer empty flag (TE)

When the send buffer is empty, this flag is set to 1, indicating that new data can be written into the SPI\_DAT register. When the send buffer is not empty, this flag is cleared to 0.

### RX buffer not empty flag (RNE)

When the receive buffer is not empty, this flag is set to 1, indicating that valid data has been received into the receive buffer. When reading the SPI\_DAT register, this flag is set to 0.

### BUSY flag (BUSY)

When the transfer starts, the BUSY flag (SPI\_STS.BUSY) is set to 1, and when the transfer ends, the BUSY flag (SPI\_STS.BUSY) is set to 0 by hardware (software operation is invalid).

In master receiving mode (SPI\_I2SCFG.MODCFG = 11), the BUSY flag (SPI\_STS.BUSY) is set to 0 during receiving. When the I2S module is turned off or the transmission is completed, this flag is set to 0.

In the slave continuous communication mode, between each data item transmission, the BUSY flag (SPI\_STS.BUSY) goes low in 1 I2S clock cycle. Therefore, do not use the BUSY flag (SPI\_STS.BUSY) to handle the sending and

receiving of each data item.

### Channel Side flag (CHSIDE)

The CHSIDE (SPI\_STS.CHSIDE) bit is used to indicate the channel where the data currently sent and received is located. Under the PCM standard, this flag has no meaning.

In send mode, the flag is updated when the TE flag (SPI\_STS.TE) is set; in receive mode, the flag is updated when the RNE flag (SPI\_STS.RNE) is set. In the process of sending and receiving, if an overflow (SPI\_STS.OVER) or underflow (SPI\_STS.UNDER) error occurs, this flag is meaningless, and the I2S needs to be turned off and then turned on again.

## 21.4.5 Error flag

The SPI\_STS register has 2 error flag bits.

### Overflow flag (OVER)

When the RNE flag (SPI\_STS.RNE) is set to 1, but there is still data sent to the receive buffer, an overflow error will occur. At this time, the OVER flag (SPI\_STS.OVER) is set to 1. An interrupt will be generated if the user enables the corresponding interrupt. All data received after this time will be lost, and the SPI\_DAT register only retains the previously unread data. Reading the SPI\_DAT register and the SPI\_STS register in turn to clear the SPI\_STS.OVER bit.

### Underflow flag (UNDER)

In slave send mode, when the first clock edge of sending data arrives, if the send buffer is still empty, the UNDER flag (SPI\_STS.UNDER) is set to 1. An interrupt will be generated if the user enables the corresponding interrupt.

Reading the SPI\_STS register to clears the SPI\_STS.UNDER bit.

## 21.4.6 I<sup>2</sup>S interrupt

The following table lists all I<sup>2</sup>S interrupts.

Table 21-3 I<sup>2</sup>S interrupt request

| Interrupt event               | Event flag bit | Enable control bit |
|-------------------------------|----------------|--------------------|
| Send buffer empty flag        | TE             | TEINTEN            |
| Receive buffer non empty flag | RNE            | RNEINTEN           |
| Underflow flag bit            | UNDER          | ERRINTEN           |
| Overflow flag bit             | OVER           |                    |

## 21.4.7 DMA function

Working in I2S mode, it does not need data transmission protection function, so it does not need to support CRC, other DMA functions are the same as SPI mode.

## 21.5 SPI and I<sup>2</sup>S register

### 21.5.1 SPI register overview

Table 21-4 SPI register overview

| Offset | Register      | 31       | 30 | 29 | 28 | 27 | 26 | 25 | 24 | 23 | 22 | 21 | 20 | 19 | 18 | 17 | 16 | 15            | 14       | 13           | 12       | 11       | 10    | 9     | 8            | 7        | 6             | 5        | 4     | 3      | 2     | 1      | 0      |   |   |   |   |   |   |   |   |   |   |
|--------|---------------|----------|----|----|----|----|----|----|----|----|----|----|----|----|----|----|----|---------------|----------|--------------|----------|----------|-------|-------|--------------|----------|---------------|----------|-------|--------|-------|--------|--------|---|---|---|---|---|---|---|---|---|---|
| 000h   | SPI_CTRL1     | Reserved |    |    |    |    |    |    |    |    |    |    |    |    |    |    |    | BIDIRMODE     | BIDIROEN | CRCEN        | CRCNEXT  | DATFF    | RONLY | SSMEN | SSEL         | LSBFF    | SPIEN         | BR[2:0]  |       |        | MSEL  | CLKPOL | CLKPHA |   |   |   |   |   |   |   |   |   |   |
|        | Reset Value   |          |    |    |    |    |    |    |    |    |    |    |    |    |    |    |    | 0             | 0        | 0            | 0        | 0        | 0     | 0     | 0            | 0        | 0             | 0        | 0     | 0      | 0     | 0      | 0      | 0 | 0 | 0 | 0 | 0 |   |   |   |   |   |
| 004h   | SPI_CTRL2     | Reserved |    |    |    |    |    |    |    |    |    |    |    |    |    |    |    |               |          |              |          |          |       |       | TEINTEN      | RNEINTEN | ERRINTEN      | Reserved |       |        | SSOEN | TDMAEN | RDMAEN |   |   |   |   |   |   |   |   |   |   |
|        | Reset Value   |          |    |    |    |    |    |    |    |    |    |    |    |    |    |    |    |               |          |              |          |          |       |       | 0            | 0        | 0             |          |       |        | 0     | 0      | 0      |   |   |   |   |   |   |   |   |   |   |
| 008h   | SPI_STS       | Reserved |    |    |    |    |    |    |    |    |    |    |    |    |    |    |    |               |          |              |          |          |       |       | BUSY         | OVER     | MODERR        | CRCERR   | UNDER | CHSIDE | TE    | RNE    |        |   |   |   |   |   |   |   |   |   |   |
|        | Reset Value   |          |    |    |    |    |    |    |    |    |    |    |    |    |    |    |    |               |          |              |          |          |       |       | 0            | 0        | 0             | 0        | 0     | 0      | 1     | 0      |        |   |   |   |   |   |   |   |   |   |   |
| 00Ch   | SPI_DAT       | Reserved |    |    |    |    |    |    |    |    |    |    |    |    |    |    |    | DAT[15:0]     |          |              |          |          |       |       |              |          |               |          |       |        |       |        |        |   |   |   |   |   |   |   |   |   |   |
|        | Reset Value   |          |    |    |    |    |    |    |    |    |    |    |    |    |    |    |    | 0             | 0        | 0            | 0        | 0        | 0     | 0     | 0            | 0        | 0             | 0        | 0     | 0      | 0     | 0      | 0      | 0 | 0 | 0 | 0 | 0 | 0 | 0 | 0 | 0 | 0 |
| 010h   | SPI_CRCPOLY   | Reserved |    |    |    |    |    |    |    |    |    |    |    |    |    |    |    | CRCPOLY[15:0] |          |              |          |          |       |       |              |          |               |          |       |        |       |        |        |   |   |   |   |   |   |   |   |   |   |
|        | Reset Value   |          |    |    |    |    |    |    |    |    |    |    |    |    |    |    |    | 0             | 0        | 0            | 0        | 0        | 0     | 0     | 0            | 0        | 0             | 0        | 0     | 0      | 0     | 0      | 0      | 0 | 0 | 0 | 1 | 1 | 1 |   |   |   |   |
| 014h   | SPI_CRCRDAT   | Reserved |    |    |    |    |    |    |    |    |    |    |    |    |    |    |    | CRCRDAT[15:0] |          |              |          |          |       |       |              |          |               |          |       |        |       |        |        |   |   |   |   |   |   |   |   |   |   |
|        | Reset Value   |          |    |    |    |    |    |    |    |    |    |    |    |    |    |    |    | 0             | 0        | 0            | 0        | 0        | 0     | 0     | 0            | 0        | 0             | 0        | 0     | 0      | 0     | 0      | 0      | 0 | 0 | 0 | 0 | 0 | 0 | 0 | 0 | 0 | 0 |
| 018h   | SPI_CRCTDAT   | Reserved |    |    |    |    |    |    |    |    |    |    |    |    |    |    |    | CRCTDAT[15:0] |          |              |          |          |       |       |              |          |               |          |       |        |       |        |        |   |   |   |   |   |   |   |   |   |   |
|        | Reset Value   |          |    |    |    |    |    |    |    |    |    |    |    |    |    |    |    | 0             | 0        | 0            | 0        | 0        | 0     | 0     | 0            | 0        | 0             | 0        | 0     | 0      | 0     | 0      | 0      | 0 | 0 | 0 | 0 | 0 | 0 | 0 | 0 | 0 | 0 |
| 01Ch   | SPI_I2SCFG    | Reserved |    |    |    |    |    |    |    |    |    |    |    |    |    |    |    | MODSEL        | I2SEN    | MODCFG [1:0] | PCMFSYNC | Reserved |       |       | STDSEL [1:0] | CLKPOL   | TDATLEN [1:0] | CHBITS   |       |        |       |        |        |   |   |   |   |   |   |   |   |   |   |
|        | Reset Value   |          |    |    |    |    |    |    |    |    |    |    |    |    |    |    |    | 0             | 0        | 0            | 0        |          |       |       | 0            | 0        | 0             | 0        | 0     | 0      |       |        |        |   |   |   |   |   |   |   |   |   |   |
| 020h   | SPI_I2SPREDIV | Reserved |    |    |    |    |    |    |    |    |    |    |    |    |    |    |    | MCLKOEN       | ODD_EVEN | LDIV[7:0]    |          |          |       |       |              |          |               |          |       |        |       |        |        |   |   |   |   |   |   |   |   |   |   |
|        | Reset Value   |          |    |    |    |    |    |    |    |    |    |    |    |    |    |    |    | 0             | 0        |              |          |          |       |       |              |          |               |          |       |        |       |        |        |   |   |   |   |   |   |   |   |   |   |

### 21.5.2 SPI control register 1 (SPI\_CTRL1) (not used in I<sup>2</sup>S mode)

Address: 0x00

Reset value: 0x0000

| 15        | 14       | 13    | 12      | 11    | 10    | 9     | 8    | 7     | 6     | 5 | 3       | 2 | 1    | 0      |        |
|-----------|----------|-------|---------|-------|-------|-------|------|-------|-------|---|---------|---|------|--------|--------|
| BIDIRMODE | BIDIROEN | CRCEN | CRCNEXT | DATFF | RONLY | SSMEN | SSEL | LSBFF | SPIEN |   | BR[2:0] |   | MSEL | CLKPOL | CLKPHA |
| rw        | rw       | rw    | rw      | rw    | rw    | rw    | rw   | rw    | rw    |   | rw      |   | rw   | rw     | rw     |

| Bit field | name      | describe  |
|-----------|-----------|---|
| 15        | BIDIRMODE | Bidirectional data mode enable<br>0: Select the "two-wire one-way" mode.<br>1: Select the "one-wire bidirectional" mode.<br><i>Note: Not used in I<sup>2</sup>S mode.</i> |

| Bit field | name     | describe   |
|-----------|----------|--|
| 14        | BIDIROEN | <p>Output enable in bidirectional mode</p> <p>0: Output disable (receive-only mode).</p> <p>1: Output enabled (send-only mode).</p> <p>In master mode, the "one-wire" data line is the MOSI pin, and in slave mode, the "one-wire" data line is the MISO pin.</p> <p><i>Note: Not used in P<sup>2</sup>S mode.</i></p>   |
| 13        | CRCEN    | <p>Hardware CRC check enable</p> <p>0: Disable CRC calculation.</p> <p>1: Enable CRC calculation.</p> <p><i>Note: This bit can only be written when SPI is disabled (SPI_CTRL1.SPIEN = 0), otherwise an error will occur.</i></p> <p>This bit can only be used in full duplex mode.</p> <p><i>Note: Not used in P<sup>2</sup>S mode.</i></p>   |
| 12        | CRCNEXT  | <p>Send CRC next</p> <p>0: The next sent value comes from the send buffer.</p> <p>1: The next send value comes from the CRC register.</p> <p><i>Note: This bit should be set immediately after the last data is written in SPI_DAT register.</i></p> <p><i>Note: Not used in P<sup>2</sup>S mode.</i></p>  |
| 11        | DATFF    | <p>Data frame format</p> <p>0: 8-bit data frame format is used for sending/receiving.</p> <p>1: 16-bit data frame format is used for sending/receiving.</p> <p><i>Note: This bit can only be written when SPI is disabled (SPI_CTRL1.SPIEN = 0), otherwise an error will occur.</i></p> <p><i>Note: Not used in P<sup>2</sup>S mode.</i></p>   |
| 10        | RONLY    | <p>Only receive mode</p> <p>This bit, together with the SPI_CTRL1.BIDIRMODE bit, determines the transfer direction in two-wire one-way mode. In the application scenario of multiple slave devices, this bit is only set to 1 by the accessed slave device, and only the accessed slave device can output, so as to avoid data line conflicts.</p> <p>0: Full duplex (sending mode and receiving mode).</p> <p>1: Disable output (receive-only mode).</p> <p><i>Note: Not used in P<sup>2</sup>S mode.</i></p> |
| 9         | SSMEN    | <p>Software slave device management</p> <p>When the SPI_CTRL1.SSMEN bit is set to 1, the NSS pin level is determined by the value of the SPI_CTRL1.SSEL bit.</p> <p>0: Disable software slave device management.</p> <p>1: Enable software slave device management.</p> <p><i>Note: Not used in P<sup>2</sup>S mode.</i></p>   |
| 8         | SSEL     | <p>Internal slave device selection</p> <p>This bit only has meaning when the SPI_CTRL1.SSMEN bit is set. It determines the NSS level, and I/O operations on the NSS pin have no effect.</p> <p><i>Note: Not used in P<sup>2</sup>S mode.</i></p>   |

| Bit field | name    | describe  |
|-----------|---------|---|
| 7         | LSBFF   | Frame format<br>0: Send MSB first.<br>1: Send LSB first.<br><i>Note: This bit cannot be changed during communication.</i><br><i>Note: Not used in P<sup>S</sup> mode.</i>   |
| 6         | SPIEN   | SPI enable<br>0: Disable SPI device.<br>1: Enable the SPI device.<br><i>Note: Not used in P<sup>S</sup> mode.</i><br><i>Note: When turning off the SPI device, please follow paragraph 21.3.4 Section's procedure operation.</i>  |
| 5:3       | BR[2:0] | Baud rate control<br>000: fPCLK/2<br>001: fPCLK/4<br>010: fPCLK/8<br>011: fPCLK/16<br>100: fPCLK/32<br>101: fPCLK/64<br>110: fPCLK/128<br>111: fPCLK/256<br><i>Note: This bit cannot be changed during communication.</i><br><i>Note: Not used in P<sup>S</sup> mode.</i> |
| 2         | MSEL    | Master device selection<br>0: Configure as the slave device.<br>1: Configure as the master device.<br><i>Note: This bit cannot be changed during communication.</i><br><i>Note: Not used in P<sup>S</sup> mode.</i>   |
| 1         | CLKPOL  | Clock polarity<br>0: In idle state, SCLK remains low.<br>1: In idle state, SCLK remains high.<br><i>Note: This bit cannot be changed during communication.</i><br><i>Note: Not used in P<sup>S</sup> mode.</i>  |
| 0         | CLKPHA  | Clock phase<br>0: Data is sampled on the first clock edge.<br>1: Data is sampled on the second clock edge.<br><i>Note: This bit cannot be changed during communication.</i><br><i>Note: Not used in P<sup>S</sup> mode.</i>   |

### 21.5.3 SPI control register 2 (SPI\_CTRL2)

Address: 0x04

Reset value: 0x0000



| Bit field | name   | describe  |
|-----------|--------|---|
| 7         | BUSY   | Busy flag<br>0: SPI is not busy.<br>1: SPI is busy communicating or the send buffer is not empty.<br>This bit is set or reset by hardware.<br><i>Note: special attention should be paid to the use of this sign, see Section 21.3.3 and Section 21.3.4 for details..</i>                          |
| 6         | OVER   | Overflow flag<br>0: No overflow error.<br>1: An overflow error occurred.<br><i>Note: This bit is set by hardware and cleared according to the sequence of software operations. For more information about software sequences, refer to 21.3.7 for details.</i>                                    |
| 5         | MODERR | Mode error<br>0: No mode error.<br>1: A mode error occurred.<br><i>Note: This bit is set by hardware and cleared according to the sequence of software operations. For more information about software sequences, refer to 21.3.7 for details.</i><br><i>Note: Not used in PS mode.</i>           |
| 4         | CRCERR | CRC error flag<br>0: The received CRC value matches the value the SPI_CRCRDAT register value.<br>1: The received CRC value does not match the SPI_CRCRDAT register value.<br><i>Note: this bit is set by hardware and cleared by software by writing 0.</i><br><i>Note: Not used in PS mode.</i>  |
| 3         | UNDER  | Underflow flag<br>0: No underflow occurred.<br>1: Underflow occurred.<br><i>Note: This bit is set by hardware and cleared according to the sequence of software operations. For more information about software sequences, refer to 21.4.5 for details.</i><br><i>Note: not used in SPI mode.</i> |
| 2         | CHSIDE | Channel<br>0: The left channel needs to be sent or received.<br>1: The right channel needs to be sent or received.<br><i>Note: not used in SPI mode. No meaning in PCM mode.</i>  |
| 1         | TE     | The send buffer is empty<br>0: The send buffer is not empty.<br>1: The send buffer is empty.  |
| 0         | RNE    | Receive buffer is not empty<br>0: The receive buffer is empty.<br>1: The receive buffer is not empty.   |

### 21.5.5 SPI data register (SPI\_DAT)

Address: 0x0C

Reset value: 0x0000

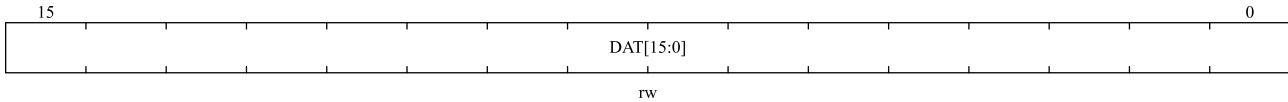

| Bit field | name      | describe  |
|-----------|-----------|---|
| 15:0      | DAT[15:0] | <p>Data register</p> <p>Data to be sent or received</p> <p>The data register corresponds to two buffers: one for write (send buffer); The other is for read (receive buffer). Write operation writes data to send buffer; The read operation will return the data in the receive buffer.</p> <p>Note on SPI mode: According to the selection of the data frame format by the SPI_CTRL1.DATFF bit, the data sending and receiving can be 8-bit or 16-bit. To ensure correct operation, the data frame format needs to be determined before enabling the SPI.</p> <p>For 8-bit data, the buffer is 8-bit, and only SPI_DAT[7:0] is used when sending and receiving.</p> <p>When receiving, SPI_DAT[15:8] is forced to 0.</p> <p>For 16-bit data, the buffer is 16-bit, and the entire data register is used when sending and receiving, that is, SPI_DAT[15:0].</p> |

### 21.5.6 SPI CRC polynomial register (SPI\_CRCPOLY) (not used in I<sup>2</sup>S mode)

Address: 0x10

Reset value: 0x0007

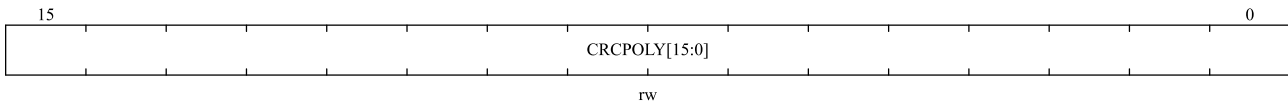

| Bit field | name           | describe   |
|-----------|----------------|--|
| 15:0      | CRCPOLY [15:0] | <p>CRC polynomial register</p> <p>This register contains the polynomial used for the CRC calculation.</p> <p>The reset value is 0x0007, other values can be set according to the application.</p> <p><i>Note: not used in I<sup>2</sup>S mode.</i></p> |

### 21.5.7 SPI RX CRC register (SPI\_CRCRDAT) (not used in I<sup>2</sup>S mode)

Address offset: 0x14

Reset value: 0x0000

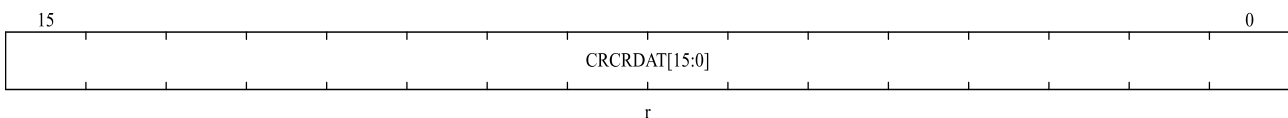

| Bit field | name | describe |
|-----------|------|----------|
|-----------|------|----------|

|      |         |   |
|------|---------|---|
| 15:0 | CRCRDAT | <p>Receive CRC register</p> <p>When CRC calculation is enabled, CRCRDAT[15:0] will contain the calculated CRC value of subsequent received bytes. This register is reset when '1' is written to the SPI_CTRL1.CRCEN bit. The CRC calculation uses the polynomial in SPI_CRCPOLY.</p> <p>When the data frame format is set to 8 bits, only the lower 8 bits participate in the calculation and follow the CRC8 standard; when the data frame format is 16 bits, all 16 bits in the register participate in the calculation and follow the CRC16 standard.</p> <p><i>Note: reading this register when the BUSY flag (SPI_STS.BUSY) is '1' may read incorrect values.</i></p> <p><i>Note: not used in I<sup>2</sup>S mode.</i></p> |
|------|---------|---|

### 21.5.8 SPI TX CRC register (SPI\_CRCTDAT)

Address offset: 0x18

Reset value: 0x0000

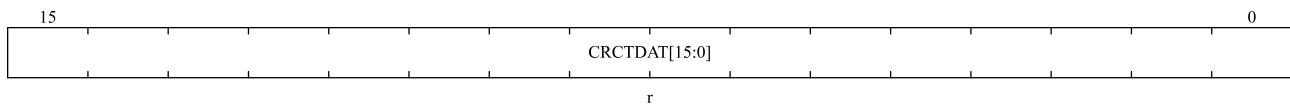

| Bit field | Name    | Description  |
|-----------|---------|--|
| 15:0      | CRCTDAT | <p>Send CRC register</p> <p>When CRC calculation is enabled, CRCTDAT[15:0] contains the CRC value calculated by the bytes sent subsequently. This register is reset when '1' is written to the SPI_CTRL1.CRCEN bit. The CRC calculation uses the polynomial in SPI_CRCPOLY.</p> <p>When the data frame format is set to 8 bits, only the lower 8 bits participate in the calculation and follow the CRC8 standard; when the data frame format is 16 bits, all 16 bits in the register participate in the calculation and follow the CRC16 standard.</p> <p><i>Note: reading this register when the BUSY flag (SPI_STS.BUSY) is '1' may read incorrect values.</i></p> <p><i>Note: not used in I<sup>2</sup>S mode.</i></p> |

### 21.5.9 SPI\_I<sup>2</sup>S configuration register (SPI\_I2SCFG)

Address offset: 0x1c

Reset value: 0x0000

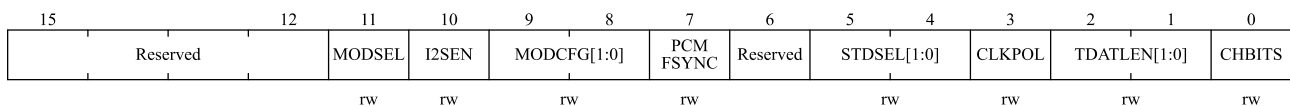

| Bit field | Name     | Description   |
|-----------|----------|---|
| 15:12     | Reserved | Reserved, the reset value must be maintained.   |
| 11        | MODSEL   | <p>I<sup>2</sup>S mode selection</p> <p>0: Select SPI mode.</p> <p>1: Select I<sup>2</sup>S mode.</p> |

| Bit field | Name               | Description   |
|-----------|--------------------|---|
|           |                    | <i>Note: this bit can only be set when SPI or I<sup>2</sup>S is turned off.</i>   |
| 10        | I <sup>2</sup> SEN | I <sup>2</sup> S enable<br>0: Disable I <sup>2</sup> S.<br>1: Enable I <sup>2</sup> S.<br><i>Note: not used in SPI mode.</i>  |
| 9:8       | MODCFG             | I <sup>2</sup> S mode setting<br>00: Slave device sends.<br>01: Slave device receives.<br>10: Master device sends.<br>11: Master device receives.<br><i>Note: This bit can only be set when I<sup>2</sup>S is turned off.</i><br><i>Note: not used in SPI mode.</i>   |
| 7         | PCMFSYNC           | PCM frame synchronization<br>0: Short frame synchronization.<br>1: Long frame synchronization.<br><i>Note: This bit is only meaningful when SPI_I2SCFG.STDSEL = 11 (used by the PCM standard).</i><br><i>Note: not used in SPI mode.</i>  |
| 6         | Reserved           | Reserved, the reset value must be maintained.   |
| 5:4       | STDSEL             | Selection of I <sup>2</sup> S standard<br>00: I <sup>2</sup> S Philips standard.<br>01: High byte alignment standard (left alignment).<br>10: Low byte alignment standard (right alignment).<br>11: PCM standard.<br>See for details of I <sup>2</sup> S standard on section 21.4.1.<br><i>Note: For correct operation, this bit can only be set when I<sup>2</sup>S is turned off.</i><br><i>Not used in SPI mode.</i> |
| 3         | CLKPOL             | Static clock polarity<br>0: I <sup>2</sup> S clock static state is low level.<br>1: I <sup>2</sup> S clock static state is high level.<br><i>Note: For correct operation, this bit can only be set when I<sup>2</sup>S is turned off.</i><br><i>Note: not used in SPI mode.</i>   |
| 2:1       | TDATLEN            | Length of data to be transmitted<br>00: 16-bit data length.<br>01: 24-bit data length;<br>10: 32-bit data length;<br>11: Not allowed.<br><i>Note: For correct operation, this bit can only be set when I<sup>2</sup>S is turned off.</i><br><i>Note: not used in SPI mode.</i>  |

| Bit field | Name   | Description   |
|-----------|--------|---|
| 0         | CHBITS | Channel length (number of data bits per audio channel)<br>0: 16 bits wide;<br>1: 32 bits wide.<br>Writing to this bit is meaningful only when SPI_I2SCFG.TDATLEN = 00, otherwise the channel length is fixed to 32 bits by hardware.<br><i>Note: For correct operation, this bit can only be set when I<sup>2</sup>S is turned off.</i><br><i>Note: not used in SPI mode.</i> |

### 21.5.10 SPI\_I<sup>2</sup>S prescaler register (SPI\_I2SPREDIV)

Address: 0x20

Reset value: 0x0002

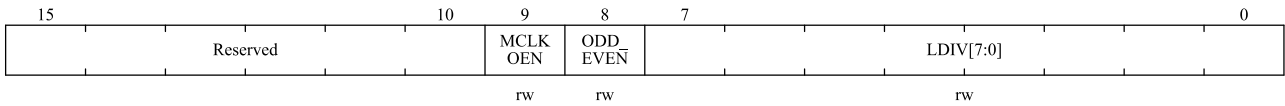

| Bit field | Name     | Description  |
|-----------|----------|--|
| 15:10     | Reserved | Reserved, the reset value must be maintained.  |
| 9         | MCLKOEN  | Master clock output enable<br>0: Disable master clock output.<br>1: Enable master clock output.<br><i>Note: For correct operation, this bit can only be set when I<sup>2</sup>S is turned off.</i><br><i>Note: not used in SPI mode.</i>   |
| 8         | ODD_EVEN | Coefficient prescaler<br>0: actual frequency division coefficient = LDIV × 2.<br>1: actual frequency division coefficient = (LDIV × 2) + 1.<br>See Section 21.4.2 for details.<br><i>Note: For correct operation, this bit can only be set when I<sup>2</sup>S is turned off. Use this bit only in I<sup>2</sup>S master mode.</i><br><i>Not used in SPI mode.</i> |
| 7:0       | LDIV     | I <sup>2</sup> S linear prescaler<br>Setting LDIV [7:0] = 0 or LDIV [7:0] = 1 is prohibited.<br>See Section 21.4.2 for details.<br><i>Note: For correct operation, this bit can only be set when I<sup>2</sup>S is turned off. Use this bit only in I<sup>2</sup>S master mode.</i><br><i>Not used in SPI mode.</i>  |

## 22 I<sup>2</sup>C interface

### 22.1 Introduction

I<sup>2</sup>C(Inter-Integrated Circuit) bus is a widely used bus structure, it has only two bidirectional lines, namely data bus SDA and clock bus SCL. All devices compatible with I<sup>2</sup>C bus can communicate directly with each other through I<sup>2</sup>C bus with these two lines.

I<sup>2</sup>C interface connects microcontroller and serial I<sup>2</sup>C bus, and can be used for communication between MCU and external I<sup>2</sup>C devices. It supports standard speed mode and fast mode, it supports CRC calculation and verification, SMBus (System Management Bus) and PMBus (Power Management Bus), it also provides multi-master function to control all I<sup>2</sup>C bus specific timing, protocol, arbitration. I<sup>2</sup>C interface module also supports DMA mode, which can effectively reduce the CPU overload.

### 22.2 Main features

- Same interface can have both master function and slave function
- Parallel-bus to I<sup>2</sup>C protocol converter
- Supports 7-bit/10-bit address mode and broadcast addressing
- As I<sup>2</sup>C master, it can generate clock, start and stop signal
- As I<sup>2</sup>C slave, it supports address detection, stop bit detection function
- Support standard speed mode(up to 100 kHz) ,fast mode(up to 400kHz) and fast plus mode(up to 1MHz)
- Support interrupt vector, byte transfer successfully interrupt and error event interrupt
- Optional clock extending function
- Support DMA mode
- Optional PEC (Packet Error Check) generation and verification
- Compatible with SMBus 2.0 and PMBus

*Note: not all of the above features are included in all products. Please refer to the relevant data manual to confirm the I<sup>2</sup>C functions supported by the product.*

### 22.3 Function description

I<sup>2</sup>C interface is connected to I<sup>2</sup>C bus through data pin (SDA) and clock pin (SCL) to communicate with external devices. It can be connected to standard (up to 100kHz) or fast (up to 400kHz) I<sup>2</sup>C bus. I<sup>2</sup>C module converts data from serial to parallel when receiving, and converts data from parallel to serial when sending. It support interrupt mode, users can enable or disable interrupt according to their needs.

#### 22.3.1 SDA and SCL line control

I<sup>2</sup>C module has two interface lines: serial data line (SDA) and serial clock line (SCL). Devices connected to the bus and transmit information to each other through these two wires. SDA and SCL are two-way wires, it should connected

to a current source or the positive of the power supply with a pull-up resistor. When the bus is idle, both lines are high level. The output of device which is connected to the bus must have open drain or open collector to provide wired-AND functionality. The data on I2C bus can reach 100 kbit/s in standard mode and 400kbit/s in fast mode. Since devices of different processors may be connected to the I2C bus, the levels of logic '0' and logic '1' are not fixed and depend on the actual level of VDD.

If the clock extending is allowed, the SCL line is pulled down which can be avoided the overload error during receiving and the under load error during transmission.

For example, when in the transmission mode, if the transmit data register is empty and the byte transmit end bit is set ( $I2C\_STS1.TXDATE = 1$ ,  $I2C\_STS1.BSF = 1$ ), the I2C interface keeps the clock line low before transmission to wait for the software to read STS1 and write the data into the data register (both buffer and shift register are empty); when In the receive mode, if the data register is not empty and the byte sending end bit is set ( $I2C\_STS1.RXDATNE = 1$ ,  $I2C\_STS1.BSF = 1$ ), the I2C interface keeps the clock line low after receiving the data byte, waiting for the software to read STS1, and then read the data register(buffer and shift register are full).

If clock extending is disable in slave mode, if the receive data register is not empty ( $I2C\_STS1.RXDATNE = 1$ ) in the receive mode, and the data has not been read before receiving the next byte, an overrun error will issue and the last word byte will be discarded. In transmit mode, if the transmit data register is empty ( $I2C\_STS1.TXDATE = 1$ ), no new data is written into the data register before the next byte must be sent, an underrun error will issue. The same byte will be send repeatedly. In this case, duplicate write conflicts are not controlled.

### 22.3.2 Software communication process

The data transmission of I2C device is divided into master and slave. Master is the device responsible for initializing the transmission of data on the bus and generating clock signal. At this time, any addressed device is a slave. Whether the I2C device is a master or a slave, it can send or receive data. Therefore, the I2C interface supports four operation modes:

- Slave transmitter mode
- Slave receiver mode
- Master transmitter mode
- Master receiver mode

After system reset, I2C works in slave mode by default. The I2C interface is configured by software to send a start bit on the bus, and then the interface automatically switches from the slave mode to the master mode. When arbitration is lost or a stop signal is generated, the interface will switched to the slave mode from the receive mode.

The block diagram of I<sup>2</sup>C interface is shown in the figure below.

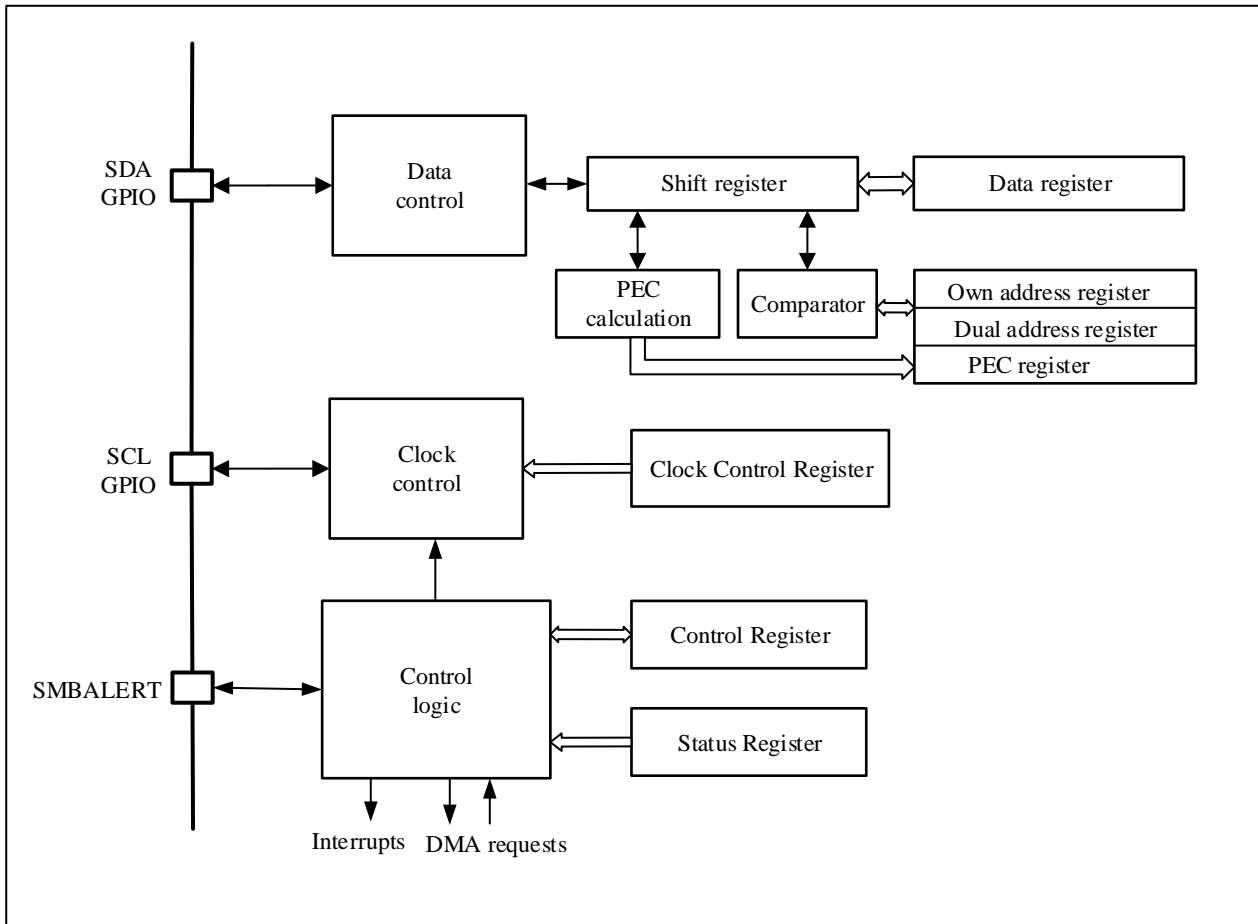
Figure 22-1 I<sup>2</sup>C functional block diagram

Note: in SMBus mode, SMBALERT is an optional signal. If SMBus is disabled, the signal cannot be used

### 22.3.2.1 Start and stop conditions

All data transfers always start with the start bit and end with the stop bit. The start and stop conditions are generated by software in the master mode. Start bit is a level conversion from high to low on SDA line when SCL is high. Stop bit is a level transition from low to high on SDA line when SCL is high, as shown in the figure below.

Figure 22-2 I2C bus protocol

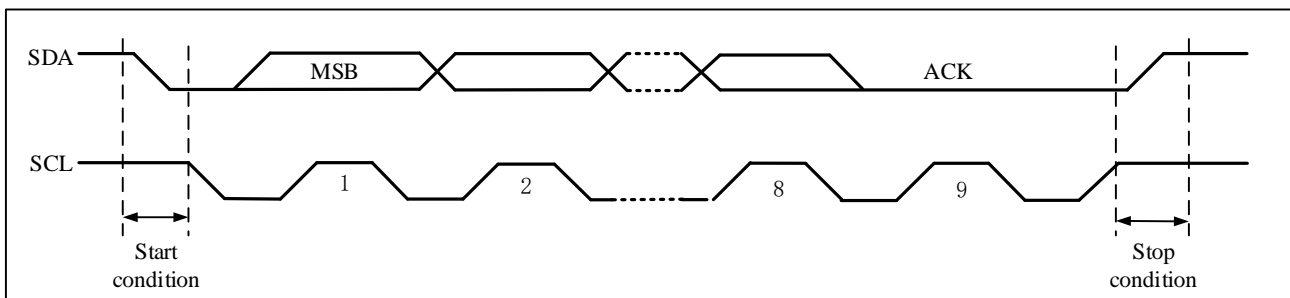

### 22.3.2.2 Clock synchronization and Arbitration

The I2C module supports multi-master arbitration, which means two masters can initiate an I2C START operation

concurrently when the bus is inactive. So some mechanisms are needed to grant a master the access to the bus. This process is generally named Clock Synchronization and Arbitration.

I2C module has two key features:

- SDA and SCL are drain open circuit structures, and the signal "wire-and" logic is realized through an external pull-up resistor.
- SDA and SCL pins will also detect the level on the pin while outputting the signal to check whether the output is consistent with the previous output. This provides the hardware basis for "Clock Synchronization" and "Bus Arbitration".

The I2C device on the bus is to output logic 0 by "grounding the line". Based on the characteristics of the I2C bus, if one device sends logic 0 and the other sends logic 1, then the line sees only logic 0, so there is no possibility of level conflicts on the line.

The physical connection of the bus allows the master to read data while writing data to the bus. In this way, when two masters are competing for the bus, the one that sends logic 0 does not know the occurrence of the competition. Only the one that sends logic 1 will find the conflict (when writing a logic 1, but read 0) and exit the competition.

### **Clock synchronization**

The high-to-low switching of the SCL line causes the devices to begin counting their low-level periods, and once the device's clock goes low, it keeps the SCL line in this state until the high-level of the clock is reached. However, if another clock is still in the low period, the low-to-high switch of this clock will not change the state of the SCL line. Therefore, the SCL line is kept low by the device with the longest low-level period. A device with a short low-level period will enter a high-level wait state.

When all related devices have counted their low-level periods, the clock line is released and goes high-level, after which there is no difference in the state of the device clock and SCL lines, and all devices will begin counting their high-level periods, the device that completes the high-level period first will pull the SCL line low again.

In this way, the low-level period of the generated synchronous SCL clock is determined by the device with the longest low-level clock period, and the high-level period is determined by the device with the shortest high-level clock period.

### **Arbitration**

Arbitration, like synchronization, is to resolve bus control conflicts in the case of multiple masters. The arbitration process has nothing to do with the slave. When the two masters both produce a valid start bit when the bus is idle, in this case, it is necessary to decide which master will complete the data transmission. This is the process of arbitration.

Each master controller does not have the priority level of controlling the bus, which is all determined by arbitration. The bus control is determined and carried out bit by bit. They follow the principle of "low level first", that is, whoever sends the low level first will control the bus. During the arbitration of each bit, when SCL is high, each host checks whether its own SDA level is the same as that sent by itself. In theory, if the content transmitted by two hosts is exactly the same, then they can successfully transmit without errors. If a host sends a high level but detects that the SDA line is low, it considers that it has lost arbitration and shuts down its SDA output driver, while the other host continues to complete its own transmission.

### **22.3.2.3 I2C data communication flow**

Each I2C device is identified by a unique address. According to the device function, they can be either a transmitter or a receiver.

The I2C host is responsible for generating the start bit and the end bit in order to start and end a transmission. And is responsible for generating the SCL clock.

The I2C module supports 7-bit and 10-bit addresses, and the user can configure the address of the I2C slave through software. After the I2C slave detects the start bit on the I2C bus, it starts to receive the address from the bus, and compares the received address with its own address. Once the two addresses are matched, the I2C slave will send an acknowledgement (ACK) and respond to subsequent commands on the bus: send or receive the requested data. In addition, if the software opens a broadcast call, the I2C slave always sends a confirmation response to a broadcast address (0x00).

Data and address are transmitted in 8-bit width, with the most significant bit first. The 1 or 2 bytes following the start condition is the address (1 byte in 7-bit mode, 2 bytes in 10-bit mode). The address is only sent in master mode. During the 9th clock period after 8 clocks of a byte transmission, the receiver must send back an acknowledge bit (ACK) to the transmitter, as shown in the Figure 22-2 I2C bus protocol.

Software can enable or disable acknowledgement (ACK), and can set the I2C interface address (7-bit, 10-bit address or general call address).

#### 22.3.2.4 I2C slave transmission mode

In slave mode, the transmission reception flag bit (I2C\_STS2.TRF) indicates whether it is currently in receiver mode or transmission mode. When sending data to I2C bus in transmission mode, the software should follow the following steps:

1. First, enable I2C peripheral clock and configure the clock related register in I2C\_CTRL1, ensuring the correct I2C timing. After these two steps are completed, I2C runs in slave mode, waiting for receiving start bit and address.
2. I2C slave receives a start bit first, and then receives a matching 7-bit or 10-bit address. I2C hardware will set the I2C\_STS1.ADDRF(received address and matched its own address). The software should monitor this bit regularly or have an interrupt to monitor this bit. After this bit is set, the software reads I2C\_STS1 register and then read I2C\_STS2 register to clear the I2C\_STS1.ADDRF bit. If the address is in 10 bit format, the I2C master should then generate a START and send an address header to the I2C bus. After detecting START and the following address header, the slave will continue to set I2C\_STS1.ADDRF bit. The software continues to read I2C\_STS1 register and read I2C\_STS2 register to clear the I2C\_STS1.ADDRF bit a second time.
3. I2C enters the data sending state, and now shift register and data register I2C\_DAT are all empty, so the hardware will set the I2C\_STS1.TXDATE(send data empty). At this time, the software can write the first byte data to I2C\_DAT register, however, because the byte of the I2C\_DAT register is immediately moved into the internal shift register, the I2C\_STS1.TXDATE bit is not cleared to zero. When the shift register is not empty, I2C starts to send data to I2C bus.
4. During the sending of the first byte, the software writes the second byte to I2C\_DAT, neither the I2C\_DAT register nor the shift register is empty. The I2C\_STS1.TXDATE bit is cleared to 0.
5. After the first byte is sent, I2C\_STS1.TXDATE is set again, and the software writes the third byte to I2C\_DAT, the same time, the I2C\_STS1.TXDATE bit is cleared. After that, as long as there is still data to be sent and I2C\_STS1.TXDATE is set to 1, the software can write a byte to I2C\_DAT register.
6. During the sending of the second last byte, the software writes the last data to the I2C\_DAT register to clear the I2C\_STS1.TXDATE flag bit, and then the I2C\_STS1.TXDATE status is no longer concerned.

I2C\_STS1.TXDATE bit is set after the second last byte is sent until the stop end bit is detected.

7. According to the I2C protocol, the I2C master will not send a ACK to the last byte received. Therefore, after the last byte is sent, the I2C\_STS1.ACKFAIL bit (acknowledge fail) of the I2C slave will be set to notify the software of the end of sending. The software writes 0 to the I2C\_STS1.ACKFAIL bit to clear this bit.

Figure 22-3 Slave transmitter transfer sequence diagram

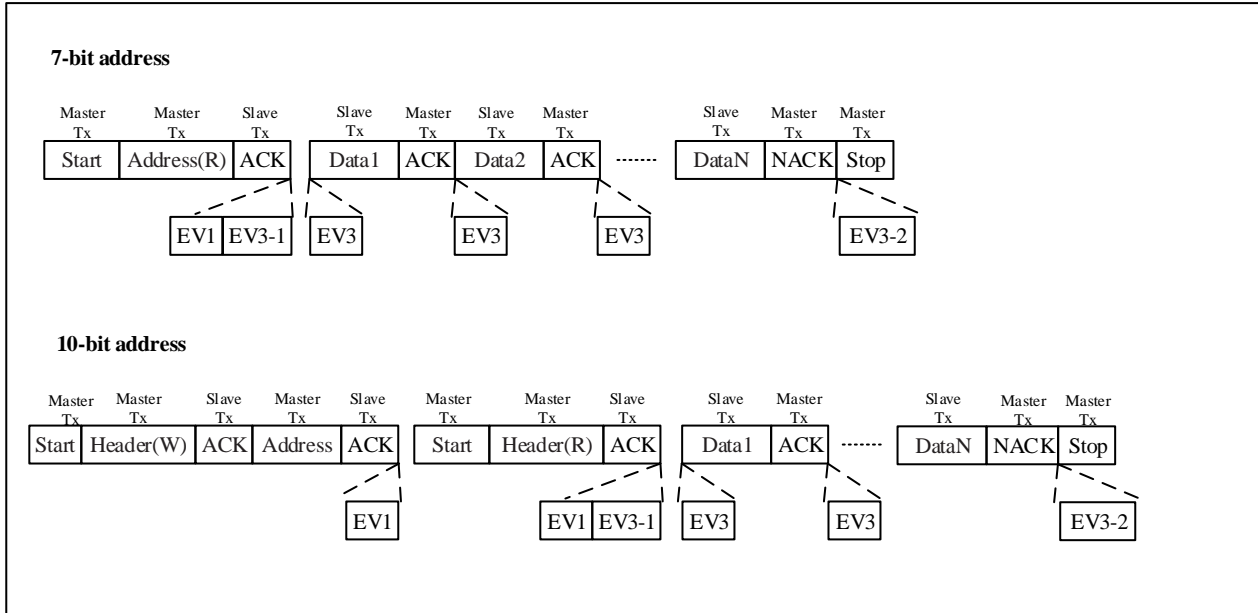

Instructions:

1. EV1: I2C\_STS1.ADDRF = 1, read STS1 and then STS2 register to clear the event.
2. EV3-1: I2C\_STS1.TXDATE=1, shift register is empty, data register is empty, write DAT.
3. EV3: I2C\_STS1.TXDATE=1, shift register is not empty, data register is empty, write DAT will clear the event.
4. EV3-2: I2C\_STS1.ACKFAIL=1, ACKFAIL bit of STS1 register write "0" to clear the event.

Note: a) EV1 and EV3\_1 event prolongs the low SCL time until the end of the corresponding software sequence.

b) The software sequence of EV3 must be completed before the end of the current byte transfer.

### 22.3.2.5 I2C slave receiving mode

When receiving data in slave mode, the software should operate as follows:

1. First, enable I2C peripheral clock and configure the clock related register in I2C\_CTRL1 ensuring the correct I2C timing. After these two steps are completed, I2C runs in slave mode, waiting for receiving start bit and address.
2. After receiving the START condition and the matched 7-bit or 10-bit address, I2C hardware will set I2C\_STS1.ADDRF bit (the address received and matched with its own address) to 1. This bit should be detected by software polling or interrupt. After it is found that it is set, the software clears the I2C\_STS1.ADDRF bit by reading I2C\_STS1 register first and then I2C\_STS2 register. Once the I2C\_STS1.ADDRF bit is cleared, the I2C slave starts to receive data from the I2C bus.
3. When the first byte is received, the I2C\_STS1.RXDATNE bit (the received data is not empty) is set to 1 by hardware. If the I2C\_CTRL2.EVTINTEN and I2C\_CTRL2.BUFINTEN bits are set, an interrupt is generated.

The software should check this bit by polling or interrupt. Once it is found that it is set, the software can read the first byte of I2C\_DAT register, and then the I2C\_STS1.RXDATNE bit is cleared to 0. Note that if the I2C\_CTRL1.ACKEN bit is set, after receiving a byte, the slave should generate a response pulse.

4. At any time, as long as the I2C\_STS1.RXDATNE bit is set to 1, the software can read a byte from the I2C\_DAT register. When the last byte is received, I2C\_STS1.RXDATNE is set to 1 and the software reads the last byte.
5. When the slave detects the STOP bit on I2C bus, set I2C\_STS1.STOPF to 1, and if the I2C\_CTRL2.EVTINTEN bit is set, an interrupt will be generated. The software clears the I2C\_STS1.STOPF bit by reading the I2C\_STS1 register before writing the I2C\_CTRL1 register (see EV4 in the following figure).

Figure 22-4 Slave receiver transfer sequence diagram

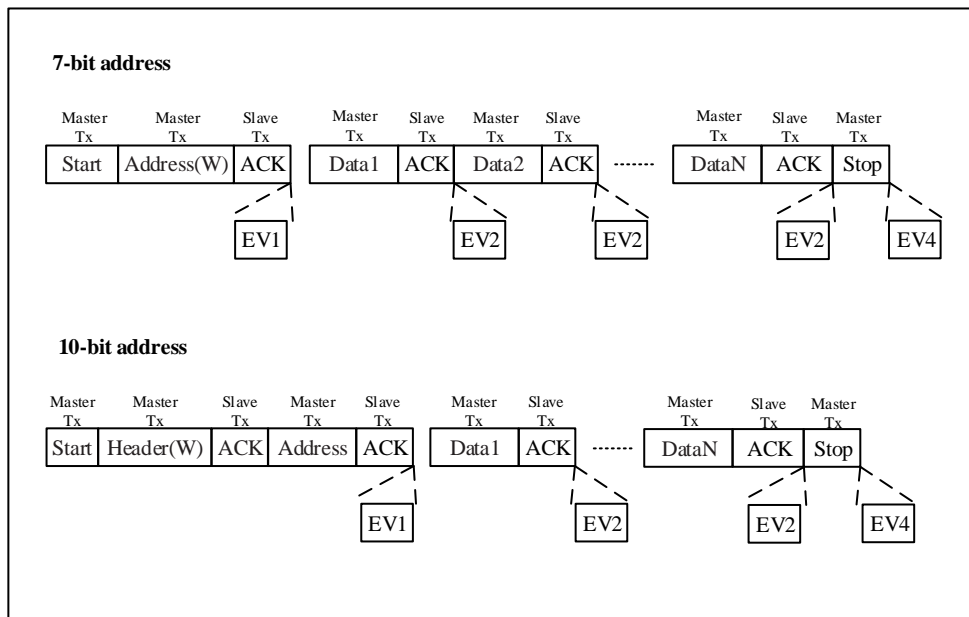

**Instructions:**

1. EV1: I2C\_STS1.ADDRF = 1, read STS1 and then STS2 to clear the event.
2. EV2: I2C\_STS1.RXDATNE =1, reading DAT will clear this event.
3. EV4: I2C\_STS1.STOPF=1, reading STS1 and then writing the CTRL1 register will clear this event.

*Note: a)EV1 event prolongs the time when SCL is low until the end of the corresponding software sequence.*

*b) The software sequence of EV2 must be completed before the end of the current byte transmission.*

**22.3.2.6 I2C master transmission mode**

In the master mode, the I2C interface starts data transmission and generates a clock signal. Serial data transmission always starts with a start condition and ends with a stop condition. When the START condition is generated on the bus through the start bit, the device enters the master mode.

When sending data to I2C bus in master mode, the software should operate as follows:

1. First, enable the I2C peripheral clock, and configure the clock-related registers in I2C\_CTRL1 to ensure the correct I2C timing. When these two steps are completed, I2C runs in the slave mode by default, waiting for receiving the start bit and address.
2. When BUSY=0, I2C\_CTRL1.STARTGEN bit set to 1, and the I2C interface will generate a start condition and

switch to the master mode (I2C\_STS2.MSMODE bit set to “1”).

3. Once the start condition is issued, I2C hardware will set I2C\_STS1.STARTBF bit (START bit flag) and then enters the master mode. If the I2C\_CTRL2.EVTINTEN bit is set, an interrupt will be generated. Then the software reads the I2C\_STS1 register and then writes a 7-bit address bit or a 10-bit address bit with an address header to the I2C\_DAT register to clear the I2C\_STS1.STARTBF bit. After the I2C\_STS1.STARTBF bit is cleared to 0, I2C starts sending addresses or address headers to I2C bus.

In 10-bit address mode, sending a header sequence will generate the following events:

- ◆ I2C\_STS1.ADDR10F bit is set by hardware, and if I2C\_CTRL2.EVTINTEN bit is set, an interrupt is generated. Then the master reads the STS1 register, and then writes the second address byte into the DAT register.
- ◆ I2C\_STS1.ADDRF bit is set by hardware, and if I2C\_CTRL2.EVTINTEN bit is set, an interrupt is generated. Then the master reads the STS1 register, followed by the STS2 register.

*Note: In the transmitter mode, the master device first sends the header byte (11110xx0) and then sends the lower 8 bits of the slave address. (where xx represents the highest 2 bits of the 10-bit address).*

In the 7-bit address mode, only one address byte needs to be sent out. Once the address byte is sent out:

- ◆ I2C\_STS1.ADDRF bit is set by hardware, and if I2C\_CTRL2.EVTINTEN bit is set, an interrupt is generated. Then the master device waits for reading the STS1 register once, followed by reading the STS2 register.

*Note: in the transmitter mode, when the master sends the slave address, set the lowest bit to "0".*

*Note: When the master transmission and in 7-bit address mode, the slave address cannot be configured as 0xF0, 0xF2, 0xF4, or 0xF6. That can prevent the I2C\_STS1.ADDR10F bit from being set by hardware.*

4. After the 7-bit or 10-bit address bit is sent, the I2C hardware sets the I2C\_STS1.ADDRF bit (address has been sent) to 1, if the I2C\_CTRL2.EVTINTEN bit is set, an interrupt is generated, and the software is cleared by reading the I2C\_STS1 register and then the I2C\_STS2 register I2C\_STS1.ADDRF.
5. I2C enters the data transmission state. Because the shift register and the data register (I2C\_DAT) are empty, the hardware sets the I2C\_STS1.TXDATE bit (transmission data empty) to 1, and then the software writes the first byte of data to the I2C\_DAT register, but because the byte written into the I2C\_DAT register is immediately moved into the internal shift register, the I2C\_STS1.TXDATE bit will not be cleared at this time. Once the shift register is not empty, I2C starts sending data to the bus.
6. During the transmission of the first byte, the software writes the second byte to I2C\_DAT, and I2C\_STS1.TXDATE is cleared at this time. At any time, as long as there is data waiting to be sent and the I2C\_STS1.TXDATE bit is set to 1, the software can write a byte to the I2C\_DAT register.
7. In the process of sending the penultimate byte, the software writes the last byte of data to I2C\_DAT to clear the I2C\_STS1.TXDATE flag bit. After that, there is no need to care about the status of the I2C\_STS1.TXDATE bit. The I2C\_STS1.TXDATE bit will be set after the penultimate byte is sent, and will be cleared when the stop bit (STOP) is sent.
8. After the last byte is sent, because the shift register and the I2C\_DAT register are empty at this time, the I2C host sets the I2C\_STS1.BSF bit (byte transmission end), and the I2C interface will keep SCL low before clearing the I2C\_STS1.BSF bit. After reading I2C\_STS1, writing to the I2C\_DAT register will clear the I2C\_STS1.BSF bit. The software sets the I2C\_CTRL1.STOPGEN bit at this time to generate a stop condition, and then the I2C interface will automatically return to the slave mode (I2C\_STS2.MSMODE bit is cleared).

Figure 22-5 Master transmitter transfer sequence diagram

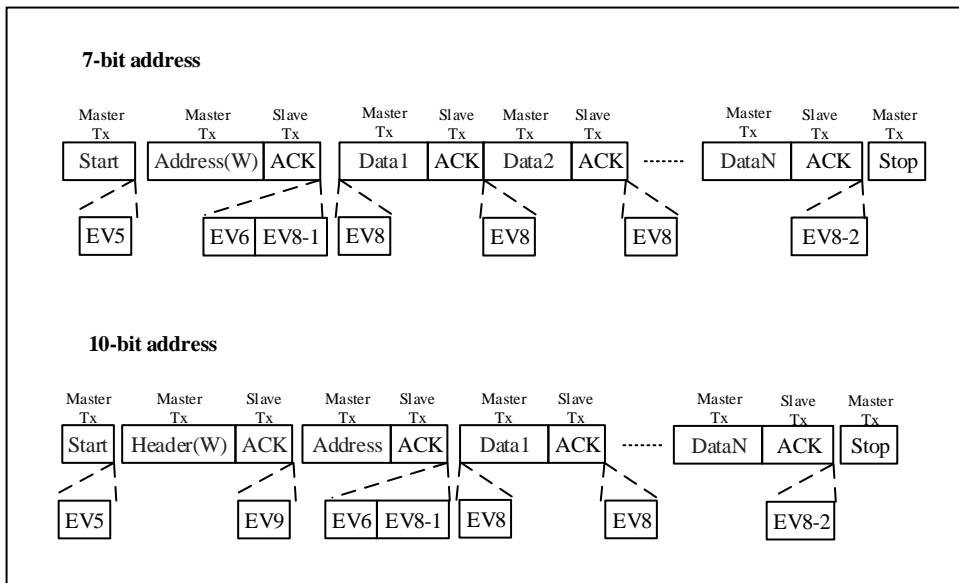
**Instructions:**

1. EV5: I2C\_STS1.STARTBF = 1, reading STS1 and writing the address to the DAT register will clear the event.
2. EV6: I2C\_STS1.ADDRF = 1, read STS1 and then STS2 to clear the event.
3. EV8\_1: I2C\_STS1.TXDATE = 1, shift register is empty, data register is empty, write DAT register.
4. EV8: I2C\_STS1.TXDATE = 1, shift register is not empty, data register is empty, write to DAT register will clear the event.
5. EV8\_2: I2C\_STS1.TXDATE = 1, I2C\_STS1.BSF = 1, request to set stop bit. These two events are cleared by the hardware when a stop condition is generated.
6. EV9: I2C\_STS1.ADDR10F = 1, read STS1 and then write to DAT register to clear the event.

*Note: a) EV5, EV6, EV9, EV8\_1 and EV8\_2 event prolonged the low SCL time until the end of the corresponding software sequence.*

*b) The software sequence of EV8 must be completed before the end of the current byte transfer.*

*c) When I2C\_STS1.TXDATE or I2C\_STS1.BSF bit is set, stop condition should be arranged when EV8\_2 occurs.*

### 22.3.2.7 I2C master receiving mode

In master mode, software receiving data from I2C bus should follow the following steps:

1. First, enable the I2C peripheral clock and configure the clock-related registers in I2C\_CTRL1, in order to ensure that the correct I2C timing is output. After enabling and configuring, I2C runs in slave mode by default, waiting to receive the start bit and address.
2. When BUSY=0, set the I2C\_CTRL.STARTGEN bit, and the I2C interface will generate a start condition and switch to the master mode (I2C\_STS2.MSMODE bit is set to 1).
3. Once the start condition is issued, the I2C hardware sets I2C\_STS1.STARTBF(start bit flag) and enters the host mode. If the I2C\_CTRL2.EVTINTEN bit is set to 1, an interrupt will be generated. Then the software reads the

I2C\_STS1 register and then writes a 7-bits address or a 10-bits address with an address header to the I2C\_DAT register, in order to clear the I2C\_STS1.STARTBF bit. After the I2C\_STS1.STARTBF bit is cleared to 0, I2C begins to send the address or address header to the I2C bus.

In 10-bits address mode, sending a header sequence will generate the following events:

- ◆ The I2C\_STS1.ADDR10F bit is set to 1 by hardware, and if the I2C\_CTRL2.EVTINTEN bit is set to 1, an interrupt will be generated. Then the master device reads the STS1 register, and then writes the second byte of address into the DAT register.
- ◆ The I2C\_STS1.ADDRF bit is set to 1 by hardware, and if the I2C\_CTRL2.EVTINTEN bit is set to 1, an interrupt will be generated. Then the master device reads the STS1 register and the STS2 register in sequence.

*Note: In the receiver mode, the master device sends the header byte (11110xx0) firstly, then sends the lower 8 bits of the slave address, and then resends a start condition followed by the header byte (11110xx1) (where xx represents the highest 2 digits of the 10-bits address).*

In the 7-bits address mode, only one address byte needs to be sent, once the address byte is sent:

- ◆ The I2C\_STS1.ADDRF bit is set to 1 by hardware, and if the I2C\_CTRL2.EVTINTEN bit is set to 1, an interrupt will be generated. Then the master device waits to read the STS1 register once, and then reads the STS2 register.

*Note:*

*In the receiving mode, the master device sets the lowest bit as '1' when sending the slave address.*

*In 7-bit address mode, don't set the slave address to 0xF0 to prevent the I2C\_STS1.ADDR10F bit from being set by hardware.*

4. After the 7-bits or 10-bits address is sent, the I2C hardware sets the I2C\_STS1.ADDRF bit (address has been sent) to 1. If the I2C\_CTRL2.EVTINTEN bit is set to 1, an interrupt will be generated. The software clears the I2C\_STS1.ADDRF bit by reading the I2C\_STS1 register and the I2C\_STS2 register in sequence. If in the 10-bit address mode, software should set the I2C\_CTRL1.STARTGEN bit again to regenerate a START. After the START is generated, the I2C\_STS1.STARTBF bit will be set. The software should clear the I2C\_STS1.STARTBF bit by reading I2C\_STS1 firstly and then writing the address header to I2C\_DAT, and then the address header is sent to the I2C bus, I2C\_STS1.ADDRF is set to 1 again. The software should clear the I2C\_STS1.ADDRF bit again by reading I2C\_STS1 and I2C\_STS2 in sequence.
5. After sending the address and clearing the I2C\_STS1.ADDRF bit, the I2C interface enters the host receiving mode. In this mode, the I2C interface receives data bytes from the SDA line and sends them to the DAT register through the internal shift register. Once the first byte is received, the hardware will set the I2C\_STS1.RXDATNE bit (not empty flag bit of received data) to 1, and if the I2C\_CTRL1.ACKEN bit is set to 1, an acknowledge pulse will be sent. At this time, the software can read the first byte from the I2C\_DAT register, and then the I2C\_STS1.RXDATNE bit is cleared to 0. After that, as long as I2C\_STS1.RXDATNE is set to 1, the software can read a byte from the I2C\_DAT register.
6. The master device sends a NACK after receiving the last byte from the slave device. After receiving the NACK, the slave device releases the control of SCL and SDA lines; the master device can send a stop/restart condition. In order to generate a NACK pulse after receiving the last byte, the software should clear the I2C\_CTRL1.ACKEN bit immediately after receiving the penultimate byte (N-1). In order to generate a stop/restart condition, the software must set the I2C\_CTRL1.STOPGEN bit or I2C\_CTRL1.STARTGEN to 1

after reading the penultimate data byte. This process needs to be completed before the last byte is received to ensure that the NACK is sent for the last byte.

- After the last byte is received, the I2C\_STS1.RXDATNE bit is set to 1, and the software can read the last byte. Since I2C\_CTRL1.ACKEN has been cleared to 0 in the previous step, I2C no longer sends ACK for the last byte, and generates a STOP bit after the last byte is sent.

*Note: The above steps require the number of bytes  $N > 1$ . If  $N = 1$ , step 6 should be executed after step 4, and it needs to be completed before the reception of byte is completed.*

Figure 22-6 Master receiver transfer sequence diagram

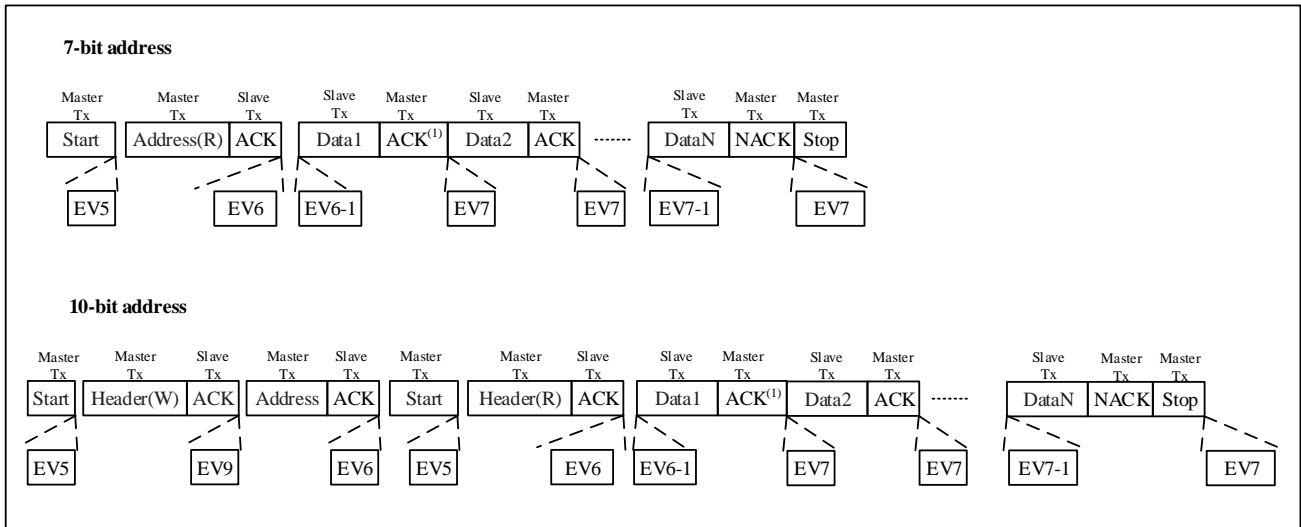

**Instructions:**

- EV5: I2C\_STS1.STARTBF=1, reading STS1 and then writing the address into the DAT register will clear this event.
- EV6: I2C\_STS1.ADDRF=1, reading STS1 and STS2 in sequence will clear this event. In the 10-bits master receiving mode, the I2C\_CTRL1.STARTGEN should be set to 1 after this event.
- EV6\_1: There is no corresponding event flag, only suitable for receiving 1 byte. Just after EV6 (that is after clearing I2C\_STS1.ADDRF), the generation bits for acknowledge and stop condition should be cleared.
- EV7: I2C\_STS1.RXDATNE=1, read the DAT register to clear this event.
- EV7\_1: I2C\_STS1.RXDATNE =1, read the DAT register to clear this event. Set I2C\_CTRL1.ACKEN=0 and I2C\_CTRL1.STOPGEN=1.
- EV9: I2C\_STS1.ADDR10F=1, reading STS1 and then writing to the DAT register will clear this event.

*Note:*

- If a single byte is received, it is NA.
- EV5, EV6, and EV9 events extend the low level of SCL until the corresponding software sequence ends.
- The EV7 software sequence shall be completed before the end of the current byte transmission.
- The software sequence of EV6\_1 or EV7\_1 shall be completed before the ACK pulse of the current transmission

byte.

### 22.3.3 Error conditions description

I2C errors mainly include bus error, acknowledge error, arbitration loss, overload\ underload error. These errors may cause communication failure.

#### 22.3.3.1 Acknowledge Failure (ACKFAIL)

The interface have a acknowledge bit is detected that does not match the expectation, it will occurs acknowledge fail error, I2C\_STS1.ACKFAIL bit is set. An interrupt occurs, when I2C\_CTRL2.ERRINTEN bit is set to 1.

When transmitter receives a NACK, The communication must be reset: Device in slave mode, hardware release the bus; Device in master mode, it must generate a stop condition from software.

#### 22.3.3.2 Bus Error (BUSERR)

when address or data is transmitting,I2C interface receive external stop or start condition,it will happen a bus error, I2C\_STS1.BUSERR bit is set. An interrupt occurs, when I2C\_CTRL2.ERRINTEN bit is set to 1.

I2C device as master, the hardware does not release bus, as the same time it done not affect the current status of transfer, The current transfer will determined by software whether suspend.

I2C device as slave, when data is discarded in transmission and the bus releases by hardware, it will have two situation: If an error start condition is detected, the slave device considers a restart condition and waits for an address or a stop condition. If an error stop condition is detected, the slave device operates as a normal stop condition and the hardware releases the bus.

#### 22.3.3.3 Arbitration Lost (ARLOST)

The interface have arbitration lost is detected, hardware release the bus, it will occurs arbitration lost error, I2C\_STS1.ARLOST bit is set. An interrupt occurs, when I2C\_CTRL2.ERRINTEN bit is set to 1.

I2C interface will go to slave mode automatically(I2C\_STS2.MSMODE bit is cleared). When the I2C interface lost the arbitration, in the same communication, it can not respond to its slave address, but it can respond when master win the bus retransmits a start signal. Hardware release the bus.

#### 22.3.3.4 Overrun/Underrun Error (OVERRUN)

In slave mode, disable clock extend prone to Overrun/Underrun Error:

When I2C interface is receiving data (I2C\_STS1.RXDATNE=1, data have received in register), and I2C\_DAT register still have previous byte has not been read, it will occurs an overrun error. In this situation, the last received data is discarded. And software should clear I2C\_STS1.RXDATNE bit, transmitter retransmit last byte.

When I2C interface is sending data (I2C\_STS1.TXDATE=1, new data have not sending to register), and I2C\_DAT register still empty, it will occurs an underrun error. In this situation, the previous byte in the I2C\_DAT register is sending repeatedly. And User make sure that in the event of an underrun error, the receiver discard repeatedly byte, and transmitter should update the I2C\_DAT register at the specified time according to the I2C bus standard.

In sending the first byte, I2C\_DAT register must be written after I2C\_STS1.ADDRF bit is cleared and the before the first SCL rising edge. If cannot make sure do that, the first byte should be discard by receiver.

## 22.3.4 DMA application

DMA can generate a requests when transfer data register empty or full. DMA can operate write data to I2C or read data from I2C reduce burden of CPU.

Before transfer current byte at the end DMA requests must be answered. If set the DMA channel transfer data is done, DMA will send EOT(End Of Transmission) to I2C, and occurs a interrupt when enable interrupt bit.

In the master transfer mode, in EOT interrupt handler DMA request need to be disable, and set stop condition after waiting for I2C\_STS1.BSF event.

In the master receive mode, the data of received is great than or equal to 2, DMA will send a hardware signal EOT\_1 in DMA transmission(byte number-1). If set I2C\_CTRL2.DMALAST bit, when hardware have send the EOT\_1 next byte it will send a NACK automatically. The user can set a stop condition in the interrupt handler after the DMA transfer is completed if interrupt enable.

*Note: When I2C and other peripherals use the same DMA controller, they cannot be turned on at the same time.*

### 22.3.4.1 Transmit process

If use the DMA mode need set the I2C\_CTRL2.DMAEN bit. When I2C\_STS1.TXDATE bit is set, the data will send to I2C\_DAT from storage area by the DMA. DMA assign a channel for I2C transmission, (x is the channel number) the following step must be operate:

1. In the DMA\_PADDRx register set the I2C\_DAT register address. Data will be send to address in every I2C\_STS1.TXDATE event.
2. In the DMA\_MADDRx register set the memory address. Data will send to I2C\_DAT address in every I2C\_STS1.TXDATE event.
3. In the DMA\_TXNUMx register set the number of need to be transferred. In every I2C\_STS1.TXDATE event this number-1 until 0.
4. In the DMA\_CHCFGx register set PRIOLVL[1:0] bit to configure the priority of channel.
5. In the DMA\_CHCFGx register set DIR bit to configure when occurs an interrupt whether send a half data or all completed.
6. In the DMA\_CHCFGx register set CHEN bit to enable transfer channel.
7. When DMA transfer data is done, DMA need send a EOT/EOT\_1 signal to I2C indicate this transfer is done. If interrupt is enable, DMA occurs a interrupt.

*Note: if DMA is used for transmission, do not set I2C\_CTRL2.BUFINTEN bit.*

### 22.3.4.2 Receive process

If use DMA mode need set I2C\_CTRL2.DMAEN bit. When data byte is received, DMA will send I2C data to storage area, set DMA channel for I2C reception. The following steps must be operate:

1. In DMA\_PADDRx register set the address of the I2C\_DAT register. In every I2C\_STS1.RXDATEN event, data will send from address to storage area.
2. In DMA\_MADDRx register set the memory area address. In every I2C\_STS1.RXDATEN event, data will send from I2C\_DAT register to storage area.

3. In DMA\_TXNUMx register set the number of need to be transferred. In every I2C\_STS1.RXDATEN event the number-1 until 0.
4. In DMA\_CHCFGx register set PRIOLVL[0:1] to configure the priority of channel.
5. In DMA\_CHCFGx register clear DIR to configure when occurs a interrupt request whether received half data or all data is received.
6. In the DMA\_CHCFGx register set CHEN bit to activate the channle.
7. When DMA transfer data is done, DMA need to send EOT/EOT\_1 signal to I2C indicate this transfer is done, if interrupt is enbale, DMA occurs a interrupt.

*Note: If DMA is used for receiving, do not set I2C\_CTRL2.BUFINTEN bit.*

### 22.3.5 Packet error check

Setting the I2C\_CTRL1.PECEN bit to 1 enables the PEC function. PEC uses CRC-8 algorithm to calculate all information bytes including address and read/write bits.it can improve the reliability of communication. The CRC-8 polynomial uses by the PEC calculator is  $C(x) = x^8 + x^2 + x + 1$ .

In transmit mode, software sets I2C\_CTRL1.PEC transfer bit in the last I2C\_STS1.TXDATE event, and then PEC will be transferred in the last byte. In receiving mode, software sets I2C\_CTRL1.PEC transfer bit after the last I2C\_STS1.RXDATNE event, and then receives the PEC byte and compares the received PEC byte to the internally calculated PEC value. If it is not equal to the internally calculated PEC value, the receiver needs to send a NACK. If it is host receiver mode, NACK will be sent after PEC regardless of the calculated result. It should pay attention that I2C\_CTRL1.PEC bit has to be set before receiving.

If both DMA and PEC calculator are activated, I2C will automatically send or check the PEC value.

In transfer mode, when I2C interface receives EOT signal from DMA controller, it will automatically send PEC following the last byte. In receiving mode, when I2C interface receives an EOT\_1 signal from DMA, it will automatically consider the next byte as PEC and compare it with the internally calculated PEC. It will happen a DMA request after receiving PEC.

In order to allow intermediate PEC transfer, I2C\_CTRL2.DMALAST bit is used to determine whether it is the last DMA transfer. And if it does the last DMA request of the master receiver, NACK will be sent automatically after receiving the last byte.

When arbitration is lost, PEC calculation is invalid.

### 22.3.6 SMBus

#### 22.3.6.1 Introduction

The System Management Bus(SMBus or SMB) is a dual-wire bus interface. Using SMBus can communicate with other device or other parts of the system, it able to commnicate with multiple devices without other independent control wire. SMBus base on I2C commnicate standard. SMBus have a control bus for system and power management related tasks. If you want browse more information, please refer to the SMBus specification V2.0(<http://smbus.org/specs/>).

SMBus have three types of device standard.

- Master: device send command, generate clocks and stop transmissions;
- Slave: device receive, respond to commands;
- Host: system have only one host. a device provides a master to system CPU. host have function of master and slave, it support SMBus alert protocol.

SMBus is a subset of the data transmission format of the I2C specification.

Similarities between SMBus and I2C:

- Both bus protocols contain of 2 wires (a clock wire SCL and a data wire SDA), with an optional SMBus alert wire.
- The data format is similar. SMBus data format is similar to 7-bit address format of I2C(See Figure 22-2).
- Both are master-slave communication modes, and the master device provides the clock.
- Both support multi master

Differences between SMBus and I2C:

Table 22-1 Comparison between SMBus and I2C

| SMBus  | I2C   |
|--|---|
| Maximum transmission speed 100kHz                            | Maximum transmission speed 1MHz                       |
| Minimum transmission speed 10kHz                             | No minimum transmission speed                         |
| Low clock timeout 35ms                                       | No clock timeout                                      |
| Fixed logic level  | VDD determined logic level                            |
| Different address types (reserved, dynamic, etc.)            | 7-bit, 10-bit, and broadcast call slave address types |
| Different bus protocols (quick command, call handling, etc.) | No bus protocol                                       |

### 22.3.6.2 SMBus usage

SMBus uses the system management bus to meet lightweight communication requirements. In general, SMBus is commonly used on the computer motherboard. It is mainly used to transmit ON/OFF instructions for power unit and provide a control bus for system and power management-related tasks.

### 22.3.6.3 Device identification

On the SMBus, as a slave have a only address for any device, named slave address.

In order to distribute address for each devices, it must have a unique device identifier(UDID) to distinguish devices.

### 22.3.6.4 Bus protocol

SMBus specification include eight bus protocols. If want browse the details on protocols or SMBus address types, it can refer to the SMBus specification v2.0(<http://smbus.org/specs/>). User's software can device what protocols are implemented.

Every packet through the SMBus complies with the SMBus protocol predefined format. SMBus is a subset of the data transfer format of I2C specification. As long as an I2C device can be accessed through one of the SMBus protocols, it is considered to be SMBus compliant.

*Note: SMBus does not support Quick command protocol.*

### 22.3.6.5 Address resolution protocol

The SMBus resolves address conflicts by dynamically assigning a new unique address to each slave device. This is the address resolution protocol(ARP) .

Any master device can connected bus to access all devices.

SMBus physical layer arbitration enable to distribute addresses. When device power on, the device's distribute address is not change, the protocol allows address retain when device power off.

When address is distributed, there is no extra SMBus packaging cost(the cost time that access distribute address device and access fixed address device is same).

### 22.3.6.6 Timeout function

A kind of feature related to timeout on SMBus: if it has taken too long time during the communication, it automatically resets the device. This is the reason why SMBus has a minimum transmission rate limitation -- to prevent the bus from locking up for a long time after the timeout occurs. I2C bus is essentially a "DC" bus, that is to say, if the slave is executing some subroutines and cannot respond in time while the master is accessing the slave, it can hold the clock. That can remind the host that the slave is busy but does not want to give up the current communication. This session can continue after the current task of the slave is over. I2c doesn't have a maximum limitation for the delay, but it is limited to 35ms in the SMBus system. According to the SMBus protocol, if a session takes too long, it means something is wrong with the bus, and all devices should be reset to eliminate this state. Like this, the slave device is not allowed to pull the clock down for too long. I2C\_STS1.TIMOUT bit indicates the status of this feature.

### 22.3.6.7 SMBus alter mode

SMBus offer a optional interrupt signal SMBALERT(like SCL and SDA,is a wired-and signal) that devices uses to extend their control capabilities at expense of a pin. SMBus broadcast call address often combine with SMBALERT. There is 2 bytes message about SMBus.

A device which only has slave function can set I2C\_CTRL1.SMBALERT bit to indicate it want to communicate with host. The host handles the interrupt and accesses all SMBALERT devices through the ARA (Alert Response Address, address value 0001100x). Only those devices that pull SMBALERT low can respond to ARA. This state is identified by the I2C\_STS1.SMBALERT. The 7-bit device address provided from the sending device is placed on the 7 most significant bits of the byte, the eighth bit can be either '0' or '1'.

When more than one device's SMBALERT is low, the highest priority(The smaller the address, the higher the priority) can win bus communication through the standard arbitration during address transmission. If confirming the slave address, device's SMBALERT is no longer pulled low. If message transmitted completely,device's SMBALERT still is low,it mean host will read ARA again. The host can periodically access the ARA when the SMBALERT signal is not used.

### 22.3.6.8 SMBus communication process

The communication process on SMBus is similar to that on I2C.To use the SMBus mode, you need to configure SMBus specific registers in the program, respond and process SMBus specific flag, to implement the upper-layer protocols described in the SMBus manual.

1. At first, set I2C\_CTRL1.SMBMODE bit, and configure I2C\_CTRL1.SMBTYPE bit and I2C\_CTRL1.ARPEN bit according to the application requirements. If I2C\_CTRL1.ARPEN=1 and I2C\_CTRL1.SMBTYPE=0, use

the default address of the SMB device. If I2C\_CTRL1.ARPEN=1 and I2C\_CTRL1.SMBTYPE=1, use the SMB master header field.

- In order to support ARP (I2C\_CTRL1.ARPEN=1), in SMBus host mode (I2C\_CTRL1.SMBTYPE=1), software needs to respond to the I2C\_STS2.SMBHADDR bit (in SMBus slave mode, respond to I2C\_STS2.SMBDADDR bit) and implement the functions according to the ARP protocol.
- To support the SMBus warning mode, software should respond to the I2C\_STS1.SMBALERT bit and implement the corresponding functions.

## 22.4 Debug mode

When the microcontroller enters the debug mode (Cortex-M4 core is in the stop state), configure the DBG\_CTRL.I2CxSMBUS\_TIMEOUT bit in the DBG module, Select SMBUS timeout to continue normal work or stop. See section 29.3.2 for details.

## 22.5 Interrupt request

All I2C interrupt requests are listed in the following table.

Table 22-2 I<sup>2</sup>C interrupt request

| Interrupt function  | Interrupt event                                  | Event flag | Set control bit       |
|---------------------|--|------------|-----------------------|
| I2C event interrupt | Start bit sent (master)                          | STARTBF    | EVTINTEN              |
|                     | Address sent (master) or address matched (slave) | ADDRF      |                       |
|                     | 10-bit header sent (master)                      | ADDR10F    |                       |
|                     | Received stop (slave)                            | STOPF      |                       |
|                     | Data byte transfer completed.                    | BSF        | EVTINTEN and BUFINTEN |
|                     | Receive buffer is not empty.                     | RXDATNE    |                       |
|                     | Send buffer is empty.                            | TXDATE     |                       |
| I2C error interrupt | Bus error  | BUSERR     | ERRINTEN              |
|                     | Lost arbitration (master)                        | ARLOST     |                       |
|                     | Acknowledge fail                                 | ACKFAIL    |                       |
|                     | Overrun/underrun                                 | OVERRUN    |                       |
|                     | PEC error  | PECERR     |                       |
|                     | Timeout /Flow error                              | TIMOUT     |                       |
|                     | SMBus Alert                                      | SMBALERT   |                       |

*Note: 1. STARTBF, ADDRf, ADDR10F, STOPF, BSF, RXDATNE and TXDATE are merged into the event interrupt channel through logical OR.*

*2. BUSERR, ARLOST, ACKFAIL, OVERRUN, PECERR, TIMEOUT and SMBALERT are merged into the error interrupt channel through logical OR.*

## 22.6 I2C registers

These peripheral registers can be operated by half word (16 bits) or word (32 bits)

## 22.6.1 I2C register overview

Table 22-3 I2C register overview

| Offset | Register    | 31       | 30 | 29 | 28 | 27 | 26 | 25 | 24 | 23 | 22 | 21 | 20 | 19 | 18 | 17 | 16 | 15 | 14          | 13       | 12       | 11            | 10       | 9           | 8        | 7         | 6            | 5        | 4        | 3     | 2       | 1        | 0       |         |   |   |   |   |   |   |
|--------|-------------|----------|----|----|----|----|----|----|----|----|----|----|----|----|----|----|----|----|-------------|----------|----------|---------------|----------|-------------|----------|-----------|--------------|----------|----------|-------|---------|----------|---------|---------|---|---|---|---|---|---|
| 000h   | I2C_CTRL1   | Reserved |    |    |    |    |    |    |    |    |    |    |    |    |    |    |    |    | SWRESET     | Reserved | SMBALERT | PEC           | ACKPOS   | ACKEN       | STOPGEN  | STARTGEN  | NOEXTEND     | GCEN     | PECEN    | ARPEN | SMBTYPE | Reserved | SMBMODE | EN      |   |   |   |   |   |   |
|        | Reset Value |          |    |    |    |    |    |    |    |    |    |    |    |    |    |    |    |    | 0           |          | 0        | 0             | 0        | 0           | 0        | 0         | 0            | 0        | 0        | 0     | 0       | 0        | 0       | 0       | 0 | 0 | 0 | 0 |   |   |
| 004h   | I2C_CTRL2   | Reserved |    |    |    |    |    |    |    |    |    |    |    |    |    |    |    |    |             |          | DMALAST  | DMAEN         | BUFINTEN | EVINTEN     | ERRINTEN | Reserved  | CLKFREQ[5:0] |          |          |       |         |          |         |         |   |   |   |   |   |   |
|        | Reset Value |          |    |    |    |    |    |    |    |    |    |    |    |    |    |    |    |    |             |          | 0        | 0             | 0        | 0           | 0        | 0         |              | 0        |          |       |         |          | 0       | 0       | 0 | 0 | 0 | 0 |   |   |
| 008h   | I2C_OADDR1  | Reserved |    |    |    |    |    |    |    |    |    |    |    |    |    |    |    |    | ADDRMODE    | Reserved | Reserved |               |          |             |          | ADDR[9:8] | ADDR[7:1]    |          |          |       |         | ADDR0    |         |         |   |   |   |   |   |   |
|        | Reset Value |          |    |    |    |    |    |    |    |    |    |    |    |    |    |    |    |    | 0           |          |          |               |          |             |          | 0         | 0            | 0        | 0        | 0     | 0       | 0        | 0       | 0       | 0 | 0 | 0 | 0 |   |   |
| 00Ch   | I2C_OADDR2  | Reserved |    |    |    |    |    |    |    |    |    |    |    |    |    |    |    |    | Reserved    |          |          |               |          | ADDR2[7:1]  |          |           |              |          | DUALEN   |       |         |          |         |         |   |   |   |   |   |   |
|        | Reset Value |          |    |    |    |    |    |    |    |    |    |    |    |    |    |    |    |    |             |          |          |               |          | 0           |          |           |              |          | 0        | 0     | 0       | 0        | 0       | 0       | 0 |   |   |   |   |   |
| 010h   | I2C_DAT     | Reserved |    |    |    |    |    |    |    |    |    |    |    |    |    |    |    |    | Reserved    |          |          |               |          | DATA[7:0]   |          |           |              |          |          |       |         |          |         |         |   |   |   |   |   |   |
|        | Reset Value |          |    |    |    |    |    |    |    |    |    |    |    |    |    |    |    |    |             |          |          |               |          | 0           |          |           |              |          | 0        | 0     | 0       | 0        | 0       | 0       | 0 | 0 |   |   |   |   |
| 014h   | I2C_STS1    | Reserved |    |    |    |    |    |    |    |    |    |    |    |    |    |    |    |    | SMBALERT    | TIMOUT   | Reserved | PECERR        | OVERRUN  | ACKFAIL     | ARLOST   | BUSERR    | TXDATE       | RXDATE   | Reserved | STOPF | ADDR10F | BSF      | ADDRF   | STARTBF |   |   |   |   |   |   |
|        | Reset Value |          |    |    |    |    |    |    |    |    |    |    |    |    |    |    |    |    | 0           | 0        |          | 0             | 0        | 0           | 0        | 0         | 0            | 0        | 0        | 0     | 0       | 0        | 0       | 0       | 0 | 0 | 0 | 0 | 0 |   |
| 018h   | I2C_STS2    | Reserved |    |    |    |    |    |    |    |    |    |    |    |    |    |    |    |    | PECVAL[7:0] |          |          |               |          | DUALFLAG    | SMBHADDR | SMBDADDR  | GCALLADDR    | Reserved | TRF      | BUSY  | MSMODE  |          |         |         |   |   |   |   |   |   |
|        | Reset Value |          |    |    |    |    |    |    |    |    |    |    |    |    |    |    |    |    | 0           |          |          |               |          | 0           | 0        | 0         | 0            | 0        | 0        | 0     | 0       | 0        | 0       | 0       | 0 | 0 |   |   |   |   |
| 01Ch   | I2C_CLKCTRL | Reserved |    |    |    |    |    |    |    |    |    |    |    |    |    |    |    |    | FSMODE      | DUTY     | Reserved | CLKCTRL[11:0] |          |             |          |           |              |          |          |       |         |          |         |         |   |   |   |   |   |   |
|        | Reset Value |          |    |    |    |    |    |    |    |    |    |    |    |    |    |    |    |    | 0           | 0        |          | 0             |          |             |          |           |              |          |          |       |         |          | 0       | 0       | 0 | 0 | 0 | 0 | 0 | 0 |
| 020h   | I2C_TMRISE  | Reserved |    |    |    |    |    |    |    |    |    |    |    |    |    |    |    |    | Reserved    |          |          |               |          | TMRISE[5:0] |          |           |              |          |          |       |         |          |         |         |   |   |   |   |   |   |
|        | Reset Value |          |    |    |    |    |    |    |    |    |    |    |    |    |    |    |    |    |             |          |          |               |          | 0           |          |           |              |          | 0        | 0     | 0       | 0        | 0       | 0       | 0 |   |   |   |   |   |

## 22.6.2 I2C Control register 1 (I2C\_CTRL1)

Address offset: 0x00

Reset value: 0x0000

| 15       | 14       | 13        | 12  | 11      | 10    | 9        | 8         | 7         | 6    | 5     | 4     | 3        | 2        | 1        | 0  |
|----------|----------|-----------|-----|---------|-------|----------|-----------|-----------|------|-------|-------|----------|----------|----------|----|
| SW RESET | Reserved | SMB ALERT | PEC | ACK POS | ACKEN | STOP GEN | START GEN | NO EXTEND | GCEN | PECEN | ARPEN | SMB TYPE | Reserved | SMB MODE | EN |
| rw       |          | rw        | rw  | rw      | rw    | rw       | rw        | rw        | rw   | rw    | rw    | rw       |          | rw       | rw |

| Bit field | Name    | Description  |
|-----------|---------|--|
| 15        | SWRESET | Software reset<br>Make sure the I2C bus is idle before resetting this bit. |

| Bit field | Name     | Description   |
|-----------|----------|---|
|           |          | 0:I2C not reset;<br>1:I2C reset.<br><i>Note: This bit can be used when the I2C_STS2.BUSY bit is set to 1 and no stop condition is detected on the bus.</i>  |
| 14        | Reserved | Reserved, the reset value must be maintained.   |
| 13        | SMBALERT | SMBus alert<br>It can be set or cleared by software. When I2C_CTRL1.EN=0, it will be cleared by hardware.<br>0: SMBAlert pin go high. The response address header is followed by the NACK signal;<br>1: SMBAlert pin go low. The response address header is followed by the ACK signal.   |
| 12        | PEC      | Packet error checking<br>It can be set or cleared by software. It will be cleared by hardware when PEC has been transferred, or by start or stop condition, or when I2C_CTRL1.EN=0.<br>0: No PEC transfer<br>1: PEC transfer.<br><i>Note: When arbitration is lost, the calculation of PEC is invalid.</i>  |
| 11        | ACKPOS   | Acknowledge/PEC Position (for data reception)<br>It can be set or cleared by software. Or when I2C_CTRL1.EN=0, it will be cleared by hardware.<br>0: I2C_CTRL1.ACKEN bit determines whether to send an ACK to the byte currently being received; I2C_CTRL1.PEC bit indicates that the byte in the current shift register is PEC.<br>1: I2C_CTRL1.ACKEN bit determines whether to send an ACK to the next received byte; I2C_CTRL1.PEC bit indicates that the next byte received in the shift register is PEC.<br><i>Note:</i><br><i>ACKPOS bit can only be used in 2-byte receiving configuration and must be configured before receiving data.</i><br><i>For the second byte of NACK, the I2C_CTRL1.ACKEN bit must be cleared after the I2C_STS1.ADDRF bit is cleared.</i><br><i>To detect the PEC of the second byte, the I2C_CTRL1.PEC bit must be set after the ACKPOS bit is configured and when the ADDR event is extended.</i> |
| 10        | ACKEN    | Acknowledge enable<br>It can be set or cleared by software. Or when I2C_CTRL1.EN equals to 0, it will be cleared by hardware.<br>0: No acknowledge send;<br>1: Send an acknowledge after receiving a byte   |
| 9         | STOPGEN  | Stop generation<br>It can be set or cleared by software. Or it will be cleared by hardware when a stop condition is detected. Or it will be set by hardware when SMBus timeout error is detected.,<br>In the master mode:<br>0: No stop condition generates;<br>1: Generate a stop condition.<br>In the slave mode:<br>0: No stop condition generates;<br>1: Release SCL and SDA lines after the current byte.  |

| Bit field | Name     | Description  |
|-----------|----------|--|
|           |          | <i>Note: When the STOPGEN, STARTGEN or PEC bit is set, the software should not take any write operation to I2C_CTRL1 until this bit is cleared by hardware. Otherwise, the STOPGEN, STARTGEN or PEC bits may be set twice.</i>   |
| 8         | STARTGEN | Start generation<br>It can be set or cleared by software. Or it will be cleared by hardware when the start condition is transferred or I2C_CTRL1.EN=0.<br>0: No start condition generates;<br>1: Generate a start conditions.  |
| 7         | NOEXTEND | Clock extending disable (Slave mode)<br>This bit determines whether to pull SCL low when the data is not ready(I2C_STS1.ADDRF or I2C_STS1.BSF flag is set) in slave mode, and is cleared by software reset<br>0: Enable Clock extending.<br>1: Disable Clock extending.  |
| 6         | GCEN     | General call enable<br>0: Disable General call. not respond(NACK) to the address 00h;<br>1: Enable General call. respond(ACK) the address 00h.   |
| 5         | PECEN    | PEC enable<br>0: Disable PEC module;<br>1: Enable PEC module.  |
| 4         | ARPEN    | ARP enable<br>0: Disable ARP;<br>1: Enable ARP.<br>If I2C_CTRL1.SMBTYPE=0, the default address of SMBus device is used.<br>If I2C_CTRL1.SMBTYPE=1, the host address of SMBus is used.  |
| 3         | SMBTYPE  | SMBus type<br>0: Device<br>1: Host   |
| 2         | Reserved | Reserved, the reset value must be maintained.  |
| 1         | SMBMODE  | SMBus mode<br>0: I2C mode;<br>1: SMBus mode.   |
| 0         | EN       | I2C Peripheral enable<br>0: Disable I2C module;<br>1: Enable I2C module<br><i>Note: If this bit is cleared when the communication is in progress, the I2C module is disabled and returns to the idle state after the current communication ends, all bits will be cleared.</i><br><i>In master mode, this bit must never be cleared until the communication has ended.</i> |

### 22.6.3 I2C Control register 2 (I2C\_CTRL2)

Address offset: 0x04

Reset value: 0x0000

|          |    |             |           |              |              |              |          |   |              |   |  |
|----------|----|-------------|-----------|--------------|--------------|--------------|----------|---|--------------|---|--|
| 15       | 13 | 12          | 11        | 10           | 9            | 8            | 7        | 6 | 5            | 0 |  |
| Reserved |    | DMA<br>LAST | DMA<br>EN | BUFINT<br>EN | EVTINT<br>EN | ERRINT<br>EN | Reserved |   | CLKFREQ[5:0] |   |  |
|          |    | rw          | rw        | rw           | rw           | rw           |          |   | rw           |   |  |

| Bit field | Name         | Description   |
|-----------|--------------|---|
| 15:13     | Reserved     | Reserved, the reset value must be maintained.   |
| 12        | DMALAST      | DMA last transfer<br>0: Next DMA EOT is not the last transfer<br>1: Next DMA EOT is the last transfer<br><i>Note: This bit is used in the master receiving mode, so that a NACK can be generated when data is received for the last time.</i>   |
| 11        | DMAEN        | DMA requests enable<br>0: Disable DMA<br>1: Enable DMA  |
| 10        | BUFINTEN     | Buffer interrupt enable<br>0: When I2C_STS1.TXDATE=1 or I2C_STS1.RXDATNE=1, any interrupt is not generated.<br>1: If I2C_CTRL2.EVTINTEN= 1, When I2C_STS1.TXDATE=1 or I2C_STS1.RXDATNE= 1, interrupt will be generated.   |
| 9         | EVTINTEN     | Event interrupt enable<br>0: Disable event interrupt;<br>1: Enable event interrupt<br>This interrupt is generated when:<br>I2C_STS1.STARTBF = 1 (Master)<br>I2C_STS1.ADDR F = 1 (Master/Slave)<br>I2C_STS1.ADD10F = 1 (Master)<br>I2C_STS1.STOPF = 1 (Slave)<br>I2C_STS1.BSF = 1 with no I2C_STS1.TXDATE or I2C_STS1.RXDATNE event<br>I2C_STS1.TXDATE = 1 if I2C_CTRL2.BUFINTEN = 1<br>I2C_STS1.RXDATNE = 1 if I2C_CTRL2.BUFINTEN = 1 |
| 8         | ERRINTEN     | Error interrupt enable<br>0: Disable error interrupt;<br>1: Enable error interrupt.<br>This interrupt is generated when:<br>I2C_STS1.BUSERR = 1;<br>I2C_STS1.ARLOST = 1;<br>I2C_STS1.ACKFAIL = 1;<br>I2C_STS1.OVERRUN = 1;<br>I2C_STS1.PECERR = 1;<br>I2C_STS1.TIMOUT = 1;<br>I2C_STS1.SMBALERT = 1.  |
| 7:6       | Reserved     | Reserved, the reset value must be maintained.   |
| 5:0       | CLKFREQ[5:0] | I2C Peripheral clock frequency<br>CLKFREQ[5:0] should be the APB clock frequency to generate the correct timing.<br>000000: Disable<br>000001: Disable  |

| Bit field | Name | Description   |
|-----------|------|---|
|           |      | 000010: 2MHz<br>000011: 3MHz<br>...<br>100100: 36MHz<br>100101~111111: Disable. |

## 22.6.4 I2C Own address register 1 (I2C\_OADDR1)

Address offset: 0x08

Reset value: 0x0000

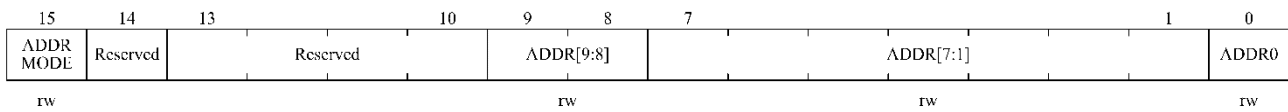

| Bit field | Name      | Description   |
|-----------|-----------|---|
| 15        | ADDRMODE  | Addressing mode (slave mode)<br>0: 7-bit slave address<br>1: 10-bit slave address                         |
| 14        | Reserved  | Must always be kept as '1' by the software.   |
| 13:10     | Reserved  | Reserved, the reset value must be maintained.   |
| 9:8       | ADDR[9:8] | Interface address<br>9~8 bits of the address.<br><i>Note: don't care these bits in 7-bit address mode</i> |
| 7:1       | ADDR[7:1] | Interface address<br>7~1 bits of the address.   |
| 0         | ADDR0     | Interface address<br>0 bit of the address.<br><i>Note: don't care these bits in 7-bit address mode</i>    |

## 22.6.5 I2C Own address register 2 (I2C\_OADDR2)

Address offset: 0x0C

Reset value: 0x0000

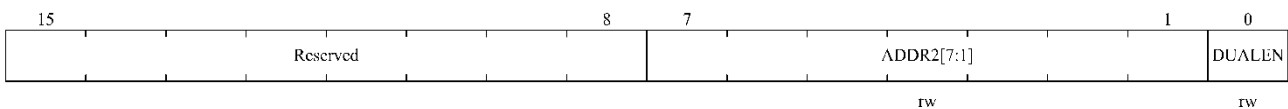

| Bit field | Name       | Description   |
|-----------|------------|---|
| 15:8      | Reserved   | Reserved, the reset value must be maintained.   |
| 7:1       | ADDR2[7:1] | Interface address<br>7~1 bits of address in dual address mode.                          |
| 0         | DUALLEN    | Dual addressing mode enable<br>0: Disable dual address mode, only OADDR1 is recognized; |



| Bit field | Name     | Description   |
|-----------|----------|---|
|           |          | <ul style="list-style-type: none"> <li>■ Master cumulative clock low extend time more than 10 ms (Tlow:mext).</li> <li>■ Slave cumulative clock low extend time more than 25 ms (Tlow:sex).</li> </ul> Timeout in slave mode: slave device resets the communication and hardware frees the bus.<br>Timeout in master mode: hardware sends the stop condition.   |
| 13        | Reserved | Reserved, the reset value must be maintained.   |
| 12        | PECERR   | PEC Error in reception<br>Writing '0' to this bit by software can clear it, or it is cleared by hardware when I2C_CTRL1.EN=0.<br>0: No PEC error<br>1: PEC error: receiver will returns NACK Whether the I2C_CTRL1.ACKEN bit is enabled   |
| 11        | OVERRUN  | Overrun/Underrun<br>Writing '0' to this bit by software can clear it, or it is cleared by hardware when I2C_CTRL1.EN=0.<br>0: No Overrun/Underrun<br>1: Overrun/Underrun<br>Set by hardware in slave mode when I2C_CTRL1.NOEXTEND=1, and when receiving a new byte in receiving mode, if the data within DAT register has not been read yet, over-run occurs, the new received byte will be lost. When transferring a new byte in transfer mode, but there is not new data that has not been written in DAT register, under-run occurs which leads that the same byte will be send twice. |
| 10        | ACKFAIL  | Acknowledge failure<br>Writing '0' to this bit by software can clear it, or it is cleared by hardware when I2C_CTRL1.EN=0.<br>0: No acknowledge failed;<br>1: Acknowledge failed.   |
| 9         | ARLOST   | Arbitration lost (master mode)<br>Writing '0' to this bit by software can clear it, or it is cleared by hardware when I2C_CTRL1.EN=0.<br>0: No arbitration lost;<br>1: Arbitration lost.<br>When the interface loses control of the bus to another host, the hardware will set this bit to '1', and the I2C interface will automatically switch back to slave mode (I2C_STS2.MSMODE=0).<br><i>Note: In SMBUS mode, the arbitration of data in slave mode only occurs in the data stage or the acknowledge transfer interval (excluding the address acknowledge).</i>                      |
| 8         | BUSERR   | Bus error<br>Writing '0' to this bit by software can clear it, or it is cleared by hardware when I2C_CTRL1.EN=0.<br>0: No start or stop condition error<br>1: Start or stop condition error   |
| 7         | TXDATE   | Data register empty (transmitters)<br>Writing data to DAT register by software can clear this bit; Or after a start or stop condition occurs, or automatically cleared by hardware when I2C_CTRL1.EN=0.<br>0: Data register is not empty;   |

| Bit field | Name     | Description   |
|-----------|----------|---|
|           |          | <p>1: Data register is empty.</p> <p>When sending data, this bit is set to '1' when the data register is empty, and it is not set at the address sending stage.</p> <p>If a NACK is received, or the next byte to be sent is PEC(I2C_CTRL1.PEC=1), this bit will not be set.</p> <p><i>Note: After the first data to be sent is written, or data is written when BSF is set, the TXDATE bit cannot be cleared, because the data register is still empty.</i></p>  |
| 6         | RXDATNE  | <p>Data register not empty(receivers)</p> <p>This bit is cleared by software reading and writing to the data register, or cleared by hardware when I2C_CTRL1.EN=0.</p> <p>0: Data register is empty;</p> <p>1: Data register is not empty.</p> <p>During receiving data, this bit is set to '1' when the data register is not empty, and it is not set at the address receiving stage.</p> <p>RXDATNE is not set when the ARLOST event occurs.</p> <p><i>Note: When BSF is set, the RXDATNE bit cannot be cleared when reading data, because the data register is still full.</i></p> |
| 5         | Reserved | Reserved, the reset value must be maintained.   |
| 4         | STOPF    | <p>Stop detection (slave mode)</p> <p>After the software reads the STS1 register, the operation of writing to the CTRL1 register will clear this bit, or when I2C_CTRL1.EN=0, the hardware will clear this bit.</p> <p>0: No stop condition is detected;</p> <p>1: Stop condition is detected.</p> <p>After a ACK, the hardware sets this bit to '1' when the slave device detects a stop condition on the bus.</p> <p><i>Note: I2C_STSI.STOPF bit is not set after receiving NACK.</i></p>   |
| 3         | ADDR10F  | <p>10-bit header sent (Master mode)</p> <p>After the software reads the STS1 register, the operation of writing to the CTRL1 register will clear this bit, or when I2C_CTRL1.EN=0, the hardware will clear this bit.</p> <p>0: No ADDR10F event;</p> <p>1: Master has sent the first address byte.</p> <p>In 10-bit address mode, when the master device has sent the first byte, the hardware sets this bit to '1'.</p> <p><i>Note: After receiving a NACK, the I2C_STSI.ADDR10F bit is not set.</i></p>   |
| 2         | BSF      | <p>Byte transfer finished</p> <p>After the software reads the STS1 register, reading or writing the data register will clear this bit; Or after sending a start or stop condition in sending mode, or when I2C_CTRL1.EN=0, this bit is cleared by hardware.</p> <p>0: Byte transfer does not finish.</p> <p>1: Byte transfer finished.</p> <p>When I2C_CTRL1.NOEXTEND =0, the hardware sets this bit to '1' in the following cases:</p>   |

| Bit field | Name    | Description  |
|-----------|---------|--|
|           |         | <p>In receiving mode, when a new byte (including ACK pulse) is received and the data register has not been read (I2C_STS1.RXDATNE=1). In sending mode, when a new data is to be transmitted and the data register has not been written with the new data (I2C_STS1.TXDATE=1).</p> <p><i>Note: After receiving a NACK, the BSF bit will not be set.</i></p> <p><i>If the next byte to be transferred is PEC (I2C_STS2.TRF is '1' and I2C_CTRL1.PEC is '1'), the BSF bit will not be set.</i></p>  |
| 1         | ADDRF   | <p>Address sent (master mode) / matched (slave mode)</p> <p>After the STS1 register is read by software, reading the STS2 register will clear this bit, or when I2C_CTRL1.EN=0, it will be cleared by hardware.</p> <p>0: Address mismatch or no address received(slave mode) or Address sending did not end(master mode);</p> <p>1: Received addresses matched(slave mode) or Address sending ends(master mode)</p> <p>In master mode:</p> <p>In 7-bit address mode, this bit is set to '1' after receiving the ACK of the address. In 10-bit address mode, this bit is set to '1' after receiving the ACK of the second byte of the address.</p> <p>In slave mode:</p> <p>Hardware sets this bit to '1' (when the corresponding setting is enabled) when the received slave address matches the content in the OADDR register, or a general call or SMBus device default address or SMBus host or SMBus alter is recognized.</p> <p><i>Note: After receiving NACK, the I2C_STS1.ADDRF bit will not be set.</i></p> |
| 0         | STARTBF | <p>Start bit (Master mode)</p> <p>After the STS1 register is read by software, writing to the data register will clear this bit, or when I2C_CTRL1.EN=0, the hardware will clear this bit.</p> <p>0: Start condition was not sent;</p> <p>1: Start condition has been sent.</p> <p>This bit is set to '1' when the start condition is sent.</p>  |

## 22.6.8 I2C Status register 2 (I2C\_STS2)

Address offset: 0x18

Reset value: 0x0000

|             |   |              |              |              |               |          |     |      |            |
|-------------|---|--------------|--------------|--------------|---------------|----------|-----|------|------------|
| 15          | 8 | 7            | 6            | 5            | 4             | 3        | 2   | 1    | 0          |
| PECVAL[7:0] |   | DUAL<br>FLAG | SMBH<br>ADDR | SMBD<br>ADDR | GCALL<br>ADDR | Reserved | TRF | BUSY | MS<br>MODE |
| r           |   | r            | r            | r            | r             |          | r   | r    | r          |

| Bit field | Name        | Description  |
|-----------|-------------|--|
| 15:8      | PECVAL[7:0] | <p>Packet error checking register</p> <p>Stores the internal PEC value When I2C_CTRL1.PECEN =1.</p>  |
| 7         | DUALFLAG    | <p>Dual flag(Slave mode)</p> <p>Hardware clears this bit when a stop condition or a repeated start condition is generated, or when I2C_CTRL1.EN=0.</p> <p>0: Received address matches the content in OADDR1;</p> <p>1: Received address matches the content in OADDR2.</p> |

| Bit field | Name      | Description  |
|-----------|-----------|--|
| 6         | SMBHADDR  | SMBus host header (Slave mode)<br>Hardware clears this bit when a stop condition or a repeated start condition is generated, or when I2C_CTRL1.EN=0.<br>0: SMBus host address was not received;<br>1: when I2C_CTRL1.SMBTYPE=1 and I2C_CTRL1.ARPEN=1, SMBus host address is received.  |
| 5         | SMBDADDR  | SMBus device default address (Slave mode)<br>Hardware clears this bit when a stop condition or a repeated start condition is generated, or when I2C_CTRL1.EN=0.<br>0: The default address of SMBus device has not been received;<br>1: when I2C_CTRL1.ARPEN=1, the default address of SMBus device is received.  |
| 4         | GCALLADDR | General call address(Slave mode)<br>Hardware clears this bit when a stop condition or a repeated start condition is generated, or when I2C_CTRL1.EN=0.<br>0: No general call address was received;<br>1: when I2C_CTRL1.GCEN=1, general call address was received.   |
| 3         | Reserved  | Reserved, the reset value must be maintained.  |
| 2         | TRF       | Transmitter/receiver<br>After detecting the stop condition (I2C_STS1.STOPF=1), repeated start condition or bus arbitration loss (I2C_STS1.ARLOST=1), or when I2C_CTRL1.EN=0, the hardware clears it.<br>0: Data receiving mode;<br>1: Data transmission mode;<br>At the end of the whole address transmission stage, this bit is set according to the R/W bit of the address byte.                             |
| 1         | BUSY      | Bus busy<br>Hardware clears this bit when a stop condition is detected.<br>0: No data communication on the bus;<br>1: Data communication on the bus.<br>When detecting that SDA or SCL is low level, the hardware sets this bit to '1';<br><i>Note: This bit indicates the bus communication currently in progress, and this information is still updated when the interface is disabled (I2C_CTRL1.EN=0).</i> |
| 0         | MSMODE    | Master/slave mode<br>Hardware clears this bit when a stop condition is detected on the bus, arbitration is lost (I2C_STS1.ARLOST=1), or when I2C_CTRL1.EN=0.<br>0: In slave mode;<br>1: In master mode.<br>When the interface is in the master mode (I2C_STS1.STARTBF=1), the hardware sets this bit;  |

## 22.6.9 I2C Clock control register (I2C\_CLKCTRL)

Address offset: 0x1c

Reset value: 0x0000

*Note: 1. F<sub>PCLK1</sub> is required to be an integer multiple of 10 MHz, so that a fast clock of 400KHz can be generated*



| Bit field | Name        | Description   |
|-----------|-------------|---|
| 15:6      | Reserved    | Reserved, the reset value must be maintained.   |
| 5:0       | TMRISE[5:0] | <p>Maximum rise time in fast/standard mode (master mode).</p> <p>These bits must be set to the maximum SCL rising time given in the I2C bus specification, and incremented step is 1.</p> <p>For example, the maximum allowable SCL rise time in standard mode is 1000ns. if the value in I2C_CTRL2.CLKFREQ [5:0] is equal to 0x08 and TPCLK1=125ns ,09h(1000ns/125 ns + 1) must be written in TMRISE[5:0] ..</p> <p>If the result is not an integer, write the integer part to TMRISE[5:0] to ensure the t<sub>HIGH</sub> parameter.</p> |

## 23 Universal synchronous asynchronous receiver transmitter (USART)

### 23.1 Introduction

USART is a full-duplex universal synchronous/asynchronous serial transceiver module. This interface is a highly flexible serial communication device that can perform full-duplex data exchange with external devices.

The USART has programmable transmit and receive baud rates and can communicate continuously using DMA. It also supports multiprocessor communication, LIN mode, synchronous mode, single-wire half-duplex communication, smart card asynchronous protocol, IrDA SIR ENDEC function, and hardware flow control function.

### 23.2 Main features

- Full-duplex operation
- Single-wire half-duplex operation
- Baud rate generator, the highest baud rate can reach 4.5Mbit/s
- Support serial data frame structure with 8 or 9 data bits, 1 or 2 stop bits
- Generation and checking of supported parity bits
- Support hardware flow control: RTS flow control and CTS flow control
- Support DMA receiving and sending
- Support multi-processor communication mode, can enter mute mode, wake up by idle detection or address mark detection
- Synchronous mode, allowing users to control bidirectional synchronous serial communication in master mode
- Comply with ISO7816-3 standard, support smart card asynchronous protocol
- IrDA SIR ENDEC function: IrDA normal mode and IrDA low power mode
- LIN (Local Area Network) mode
- Support data overflow error detection, frame error detection, noise error detection, parity error detection
- Interrupt requests include: transmit data register empty, CTS flag, transmit complete, receive data ready to read, data overflow detected, idle line detected, parity error, LIN break frame detection, noise flag/overflow error/frame error in multi-buffer communication

## 23.3 Functional block diagram

Figure 23-1 USART block diagram

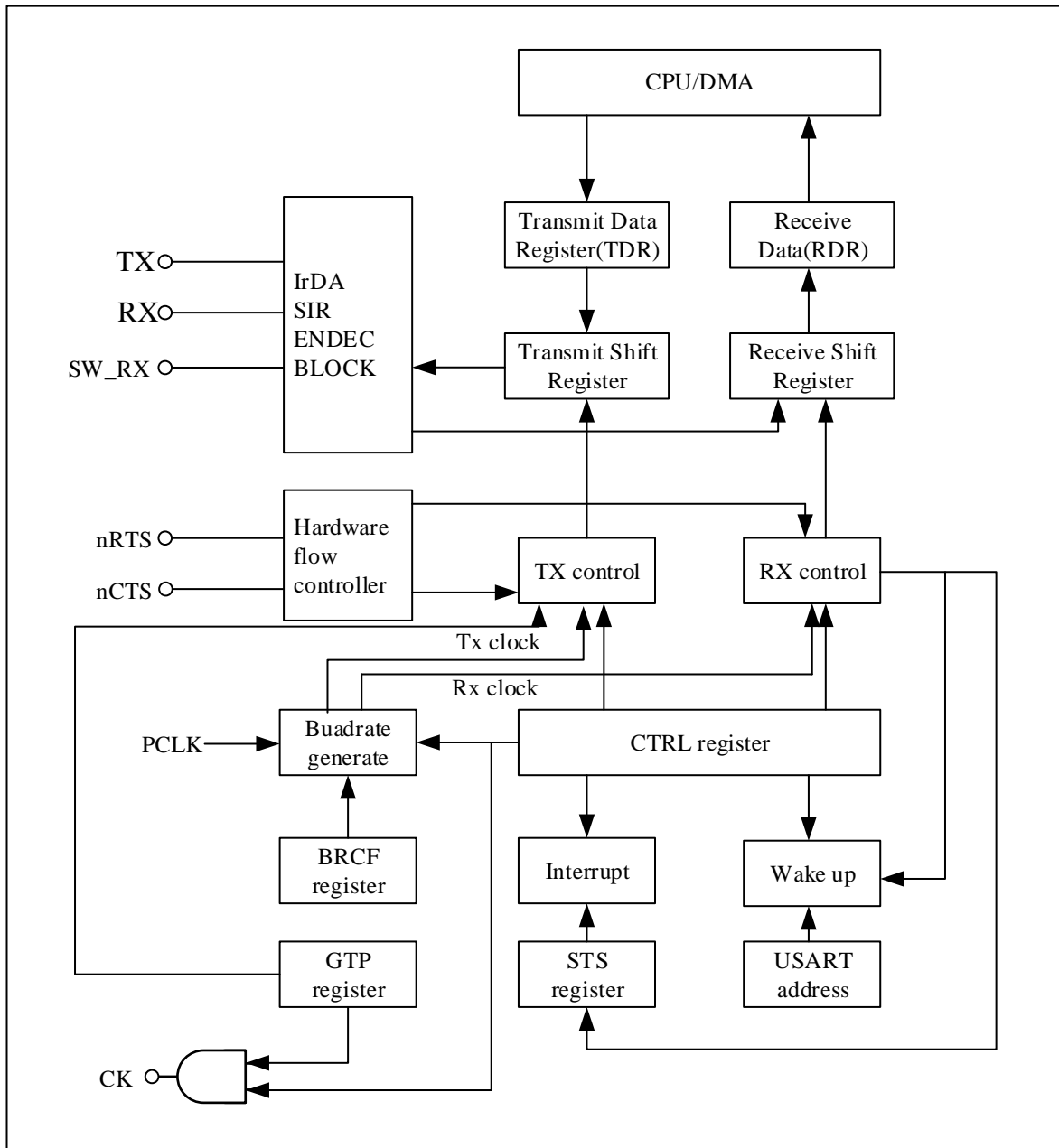

## 23.4 Function description

As shown in the Figure 23-1, the bidirectional communication of any USART needs to use the RX and TX pins of the external connection. Among them, TX is the output pin for serial data transmission. When the transmitter is active and not sending data, the TX pin is pulled high. When the transmitter is inactive, the TX pin reverts to the I/O port configuration. RX is an input pin for serial data reception, data is recovered by oversampling technique.

The data packets of serial communication are transmitted from the sending device to the RX interface of the receiving device through its own TX interface, and the bus is in an idle state before sending or receiving. Frame format is: 1

start bit + 8 or 9 data bits (least significant bit first) + 1 parity bit (optional) + 0.5,1,1.5 or 2 stop bit.

Use the fractional baud rate generator to configure transmit and receive baud rates.

According to the block diagram, when using the hardware flow control mode, the nRTS output and nCTS input pins are required. When the USART receiver is ready to receive new data, nRTS becomes low level. If nCTS is valid (pulled to a low level), the next data is sent, otherwise the next frame of data is not sent.

When using synchronous mode, the CK pin is required. The CK pin is used for clock output for synchronous transfers. Clock phase and polarity are software programmable. During the start and stop bits, the CK pin does not output clock pulses. The CK pin is also used when using smart card mode.

### 23.4.1 USART frame format

The start bit of the data frame is low.

The word length can be selected as 8 or 9 bits by programming the USART\_CTRL1.WL bits, least significant bit first.

The stop bit of the data frame is high.

An idle frame is a complete data frame consisting of '1's, including the start bit. followed by the start bit of a data frame containing the data .

A break frame is a complete data frame consisting of '0's, including the stop bit. at the end of the break frame, the transmitter inserts 1 or 2 more stop bits ('1') to acknowledge the start bit.

Figure 23-2 word length = 8 setting

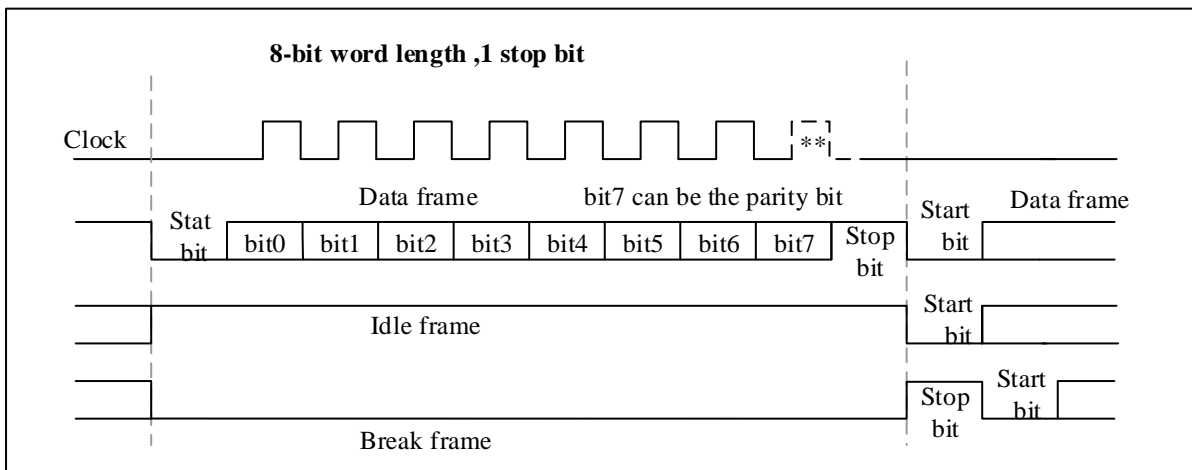
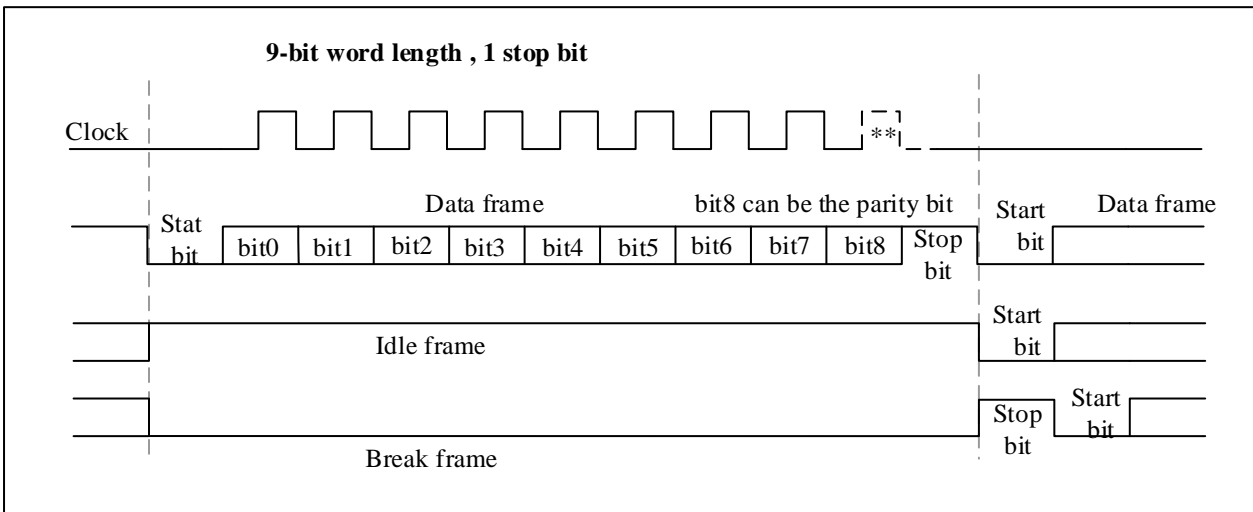

Figure 23-3 word length = 9 setting



## 23.4.2 Transmitter

After the transmitter is enabled, the data entered into the transmit shift register is sent out through the TX pin.

### 23.4.2.1 Idle frame

Setting `USART_CTRL1.TXEN` will cause the USART to transmit an idle frame before the first data frame.

### 23.4.2.2 Character send

Idle frames are followed by characters sent. Each character is preceded by a low start bit. The transmitter sends 8-bit or 9-bit data according to the configuration of the data bit length, with the least significant bit first. If `USART_CTRL1.TXEN` is reset during a data transfer, it will cause the baud rate counter to stop counting and the data being transferred will be corrupted.

### 23.4.2.3 Stop bit

The characters are followed by stop bits, the number of which can be configured by setting `USART_CTRL2.STPB[1:0]`.

Table 23-1 Stop bit configuration

| <code>USART_CTRL2.STPB[1:0]</code> | Stop bit length (bits) | functional description                               |
|------------------------------------|------------------------|--|
| 00                                 | 1                      | default  |
| 01                                 | 0.5                    | Receiving in Smartcard mode                          |
| 10                                 | 2                      | General USART mode, single-wire mode and modem mode. |
| 11                                 | 1.5                    | Transmitting and receiving in Smartcard mode         |

Figure 23-4 configuration stop bit

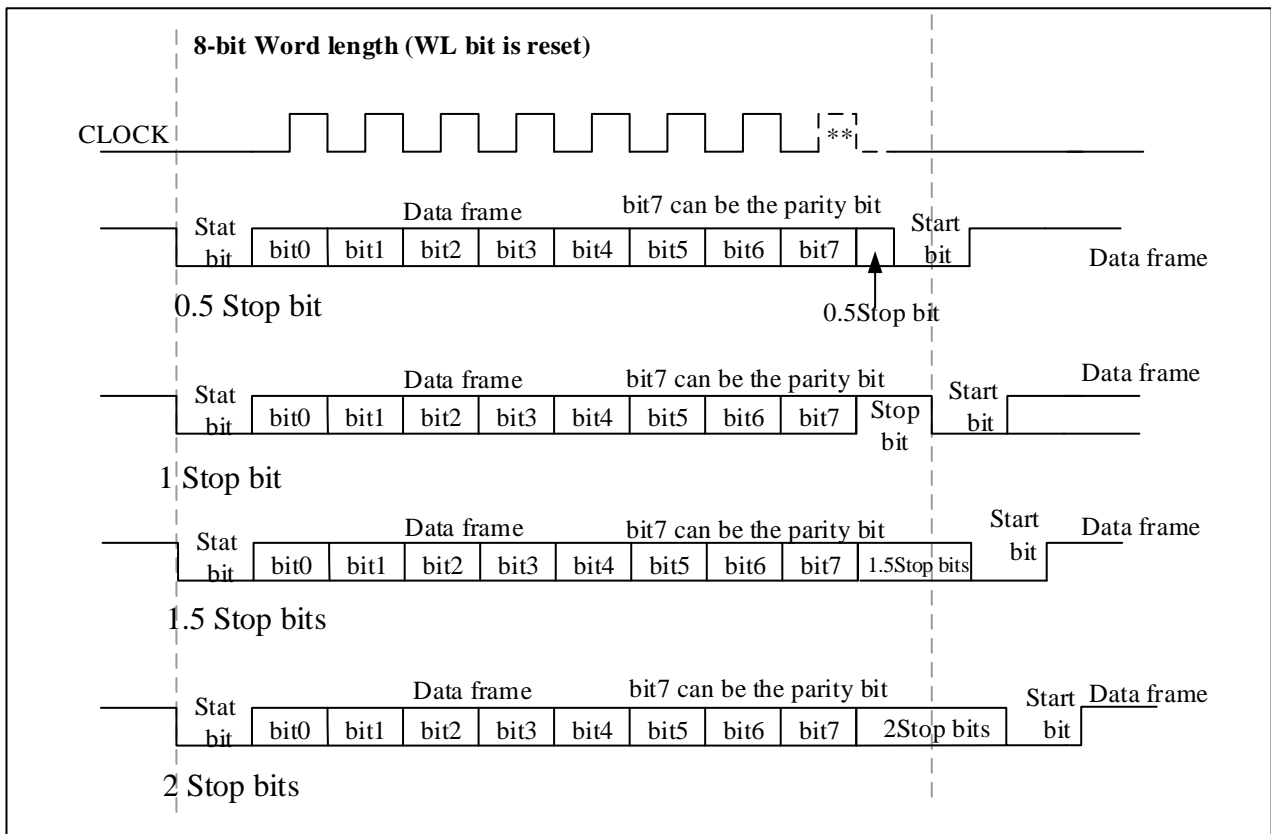

#### 23.4.2.4 Break frame

Use `USART_CTRL1.SDBRK` to send the break character. When there is 8-bit data, the break frame consists of 10 bits of low level, followed by a stop bit; when there is 9-bit data, the break frame consists of 11 bits of low level, followed by a stop bit.

After the break frame is sent, `USART_CTRL1.SDBRK` is cleared by hardware, and the stop bit of the break frame is being sent. Therefore, to send a second break frame, `USART_CTRL1.SDBRK` should be set after the stop bit of the previous break frame has been sent.

If software resets the `USART_CTRL1.SDBRK` bit before starting to send the break frame, the break frame will not be sent.

#### 23.4.2.5 Transmitter process

1. Enable `USART_CTRL1.UEN` to activate USART;
2. Configure the transmitter's baud rate, data bit length, parity bit (optional), the number of stop bits or DMA configuration;
3. Activate the transmitter (`USART_CTRL1.TXEN`);
4. Send each data to be sent to the `USART_DAT` register through the CPU or DMA, and the write operation to the `USART_DAT` register will clear `USART_STS.TXDE`;
5. After writing the last data word in the `USART_DAT` register, wait for `USART_STS.TXC = 1`, which indicates the end of the transmission of the last data frame.

Note: There will be a delay of 0 to 1 baud rate cycle when writing data to `UART_DAT` before the data appears on the `UART_TX` pin. For example, at a baud rate of 100K as shown in Figure below, if data is written to `UART_DAT` at any point within one baud rate cycle, it will be transmitted to the `UART_TX` pin at the beginning of the next baud rate cycle.

Figure 23-5 Transmission time difference

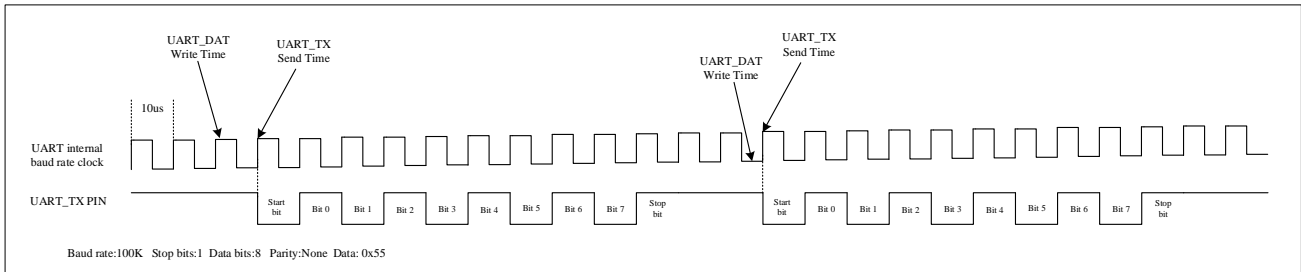

### 23.4.2.6 Single byte communication

A write to the `USART_DAT` register clears the `USART_STS.TXDE` bit.

The `USART_STS.TXDE` bit is set by hardware when the data in the `TDR` register is transferred to the transmit shift register (indicating that data is being transmitted). An interrupt will be generated if `USART_CTRL1.TXDEIEN` is set. At this point, the next data can be sent to the `USART_DAT` register because the `TDR` register has been cleared and will not overwrite the previous data.

Write operation to `USART_DAT` register:

- When the transmit shift register is not sending data and is in an idle state, the data is directly put into the shift register for transmission, and the `USART_STS.TXDE` bit is set by hardware;
- When the transmit shift register is sending data, the data is stored in the `TDR` register, and after the current transmission is completed, the data is put into the shift register.

When a frame containing data is sent and `USART_STS.TXDE=1`, the `USART_STS.TXC` bit is set to '1' by hardware. An interrupt is generated if `USART_CTRL1.TXCEN` is '1'. `USART_STS.TXC` bit is cleared by a software sequence (read `USART_STS` register first, then write `USART_DAT` register).

Figure 23-6 TXC/TXDE changes during transmission

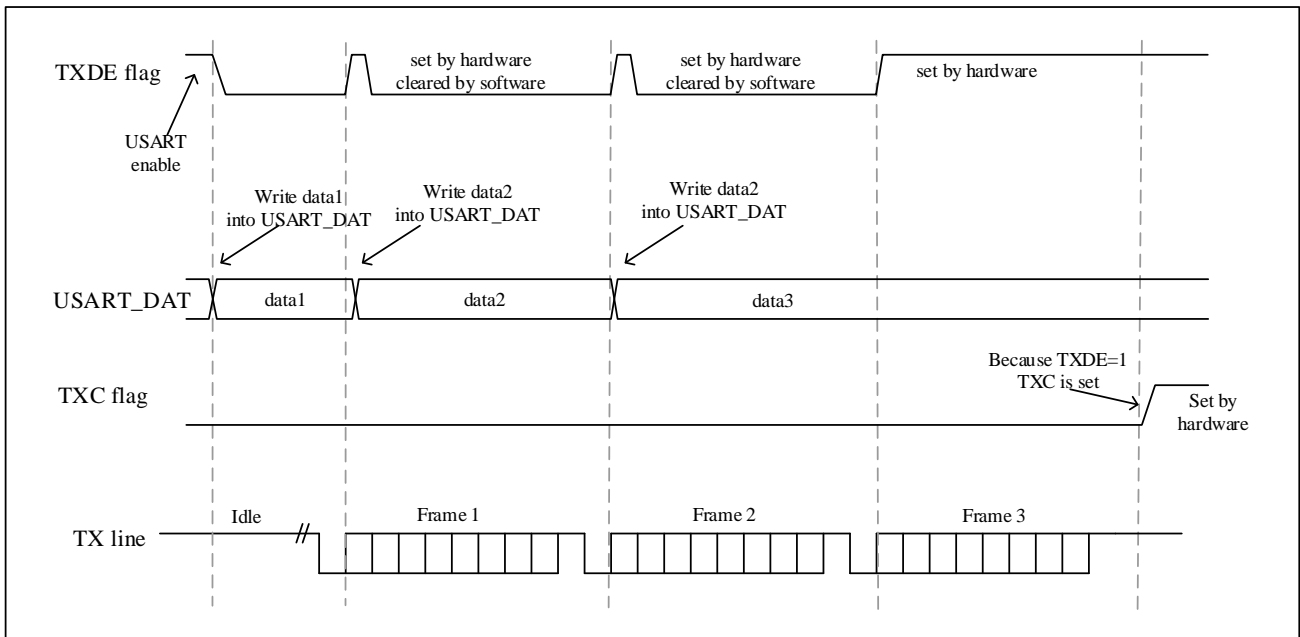

## 23.4.3 Receiver

### 23.4.3.1 Start bit detection

When the received sampling sequence is: 1 1 1 0 X 0 X 0 X 0 0 0 0, it is considered that a start bit is detected.

The samples at the 3rd, 5th, and 7th bits, and the samples at the 8th, 9th, and 10th bits are all '0' (that is, 6 '0'), then confirm the receipt of the start bit, the USART\_STS.RXDNE flag bit is set, and if USART\_CTRL1.RXDNEIEN=1, an interruption occurs and will not Set the NEF noise flag.

The samples of the 3rd, 5th, and 7th bits have two '0' points, and at the same time, the samples of the 8th, 9th, and 10th bits have three '0' points, then the start bit is confirmed, but it will be set NEF noise flag.

The samples of the 3rd, 5th, and 7th bits have three '0' points, and at the same time, the samples of the 8th, 9th, and 10th bits have two '0' points, then the start bit is confirmed, but it will be set NEF noise flag.

The samples of the 3rd, 5th, and 7th bits have two '0' points, and at the same time, the samples of the 8th, 9th, and 10th bits have two '0' points, then it is confirmed that the start bit is received, but it will be set bit NEF noise flag.

If the sampling values in the 3rd, 5th, 7th, 8th, 9th and 10th bits cannot meet the above four requirements, the USART receiver thinks that it has not received the correct start bit, and will exit the start bit detection and Return to idle state and wait for falling edge.

Figure 23-7 Start bit detection

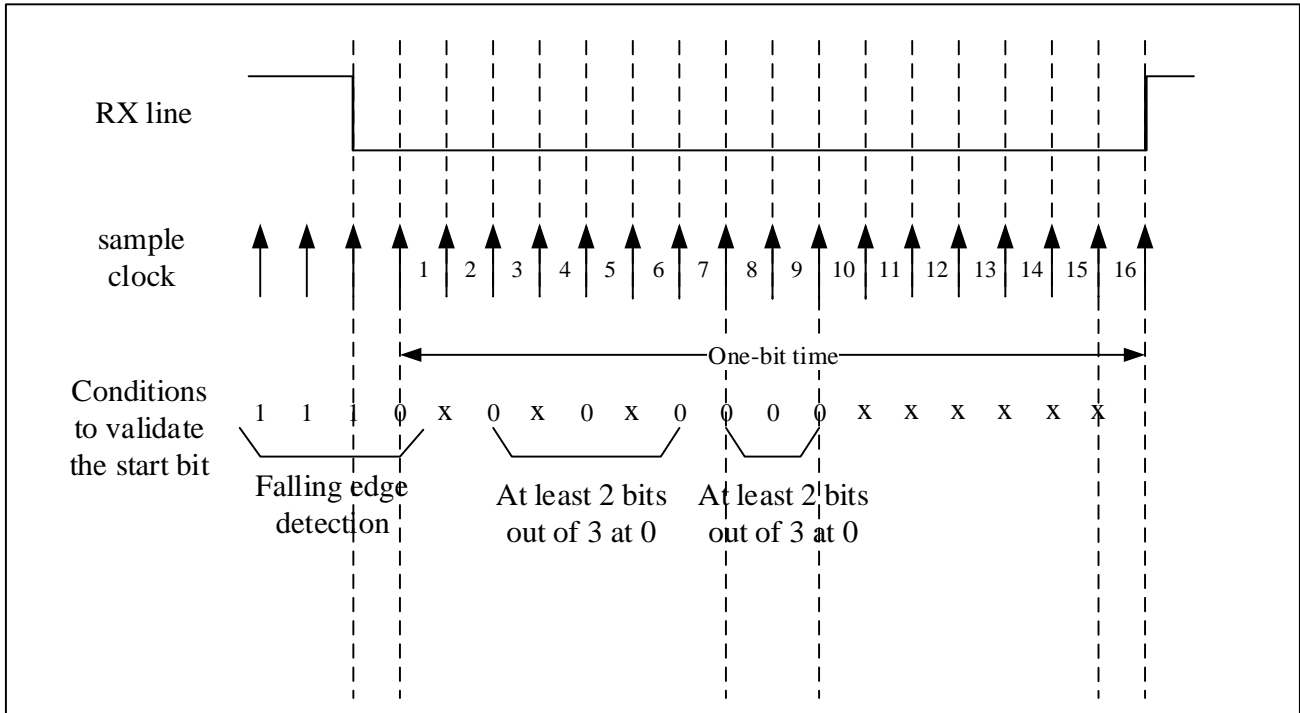

### 23.4.3.2 Stop bit description

During data reception, the number of data stop bits can be configured by the `USART_CTRL2.STPB[1:0]`. In normal mode, 1 or 2 stop bits can be selected. In Smartcard mode, 0.5 or 1.5 stop bits can be selected.

1. 0.5 stop bits (receive in smartcard mode): 0.5 stop bits are not sampled. Therefore, if 0.5 stop bits is selected, framing errors and broken frames cannot be detected.
2. 1 stop bit: the sampling of one stop bit is carried out through three points, and the 8th, 9th and 10th sampling bits are selected.
3. 1.5 stop bit (Smartcard mode): when sending in Smartcard mode, the device must check whether the data is sent correctly. So the receiver function block must be activated (`USART_CTRL1.RXEN=1`) and sample the signal on the data line during the transmission of the stop bit. If a parity error occurs, the smartcard will pull down the data line when the transmitter samples the NACK signal, that is, within the time corresponding to the stop bit on the bus, indicating that a framing error has occurred. The `USART_STS.FEF` is set together with the `USART_STS.RXDNE` at the end of the 1.5th stop bit. The 1.5 stop bits were sampled at points 16, 17 and 18. The 1.5 stop bits can be divided into two parts: one is 0.5 clock cycles, during which nothing is done. This is followed by the stop bit of 1 clock cycle, which is sampled at the midpoint of this period of time. For details, see 23.4.14 Smartcard mode.
4. 2 stop bits: the sampling of the 2 stop bits is completed at the 8th, 9th and 10th sampling points of the first stop position. If a frame error is detected during the first stop bit, the frame error flag is set. The second stop bit does not detect framing error. The `USART_STS.RXNE` flag will be set at the end of the first stop bit.

### 23.4.3.3 Receiver process

1. Enable `USART_CTRL1.UEN` to activate USART;
2. Configure the receiver's baud rate, data bit length, parity bit (optional), stop bit number or DMA configuration;
3. Activate the receiver (`USART_CTRL1.RXEN`) and start looking for the start bit;

4. The receiver receives 8-bit or 9-bit data according to the configuration of the data bit length, and the least significant bit of the data is first shifted from the RX pin into the receive shift register;
5. When the data of the received shift register is moved to the RDR register, USART\_STS.RXDNE is set, and the data can be read out. If USART\_CTRL1.RXNEIEN is 1, an interrupt will be generated;
6. When an overflow error, noise error, or frame error is detected in the received frame, the corresponding error flag status bit will be set. If USART\_CTRL1.RXEN is reset during data transmission, the data being received will be lost;
7. USART\_STS.RXDNE is set after receiving data, and a read operation of USART\_DAT can clear this bit:
  - During multi-buffer communication, the data register is cleared by the DMA read operation;
  - During single-buffer communication, it is cleared by software reading the USART\_DAT register.

#### 23.4.3.4 Idle frame detection

The receiver of the USART can detect idle frames. An interrupt is generated if USART\_CTRL1.IDLEIEN is '1'. USART\_STS.IDLEF bit is cleared by a software sequence (read USART\_STS register first, then read USART\_DAT register).

#### 23.4.3.5 Break frame detection

The frame error flag(USART\_STS.FEF) is set by hardware when the receiver detects a break frame. It can be cleared by a software sequence (read USART\_STS register first, then read USART\_DAT register).

#### 23.4.3.6 Framing error

A framing error occurs when a stop bit is not received and recognized at the expected time. At this time, the frame error flag USART\_STS.FEF will be set by hardware, and the invalid data will be transferred from the shift register to the USART\_DAT register. During single-byte communication, no framing error interrupt will be generated because it occurs with USART\_STS.RXDNE and the hardware will generate an interrupt when the USART\_STS.RXDNE flag is set. In multi-buffer communication mode, an interrupt will be generated if the USART\_CTRL3.ERRIEN bit is set.

#### 23.4.3.7 Overrun error

When USART\_STS.RXDNE is still '1', when the data currently received in the shift register needs to be transferred to the RDR register, an overflow error will be detected, and the hardware will set USART\_STS.OREF. When this bit is set, the value in the RDR register is not lost, but the data in the shift register is overwritten. It is cleared by a software sequence (read USART\_STS register first, then write USART\_DAT register).

When an overflow error occurs, USART\_CTRL1.RXDNEIEN is '1', and an interrupt is generated. If the USART\_CTRL3.ERRIEN bit is set, an interrupt will be generated when the USART\_STS.OREF flag is set in multi-buffer communication mode.

#### 23.4.3.8 Noise error

USART\_STS.NEF is set by hardware when noise is detected on a received frame. It is cleared by software sequence (read USART\_STS register first, then write USART\_DAT register). During single-byte communication, no noise interrupt generated because it occurs with USART\_STS.RXDNE and the hardware will generate an interrupt when the USART\_STS.RXDNE flag is set. In multi-buffer communication mode, an interrupt is generated when the USART\_STS.NEF flag is set if the USART\_CTRL3.ERRIEN bit is set.

Table 23-2 Data sampling for noise detection

| Sample value | NE status | Received bits | Data validity |
|--------------|-----------|---------------|---------------|
| 000          | 0         | 0             | Effective     |
| 001          | 1         | 0             | be invalid    |
| 010          | 1         | 0             | be invalid    |
| 011          | 1         | 1             | be invalid    |
| 100          | 1         | 0             | be invalid    |
| 101          | 1         | 1             | be invalid    |
| 110          | 1         | 1             | be invalid    |
| 111          | 0         | 1             | Effective     |

### 23.4.4 Generation of fractional baud rate

The baud rate of the USART can be configured in the USART\_BRCF register. This register defines the integer and fractional parts of the baud rate divider. The baud rate of the transmitter and receiver should be configured to the same value. Be careful not to change the value of the USART\_BRCF register during communication, because the baud rate counter will be replaced by the new value of the baud rate register.

$$\text{TX / RX baud rate} = f_{\text{PCLK}} / (16 * \text{USARTDIV})$$

where  $f_{\text{PCLK}}$  is the clock provided to the peripheral:

- PCLK1 is used for USART2, USART3, UART4, UART5, up to 36MHz;
- PCLK2 is used for USART1, UART6, UART7, up to 72MHz.

USARTDIV is an unsigned fixed-point number.

#### 23.4.4.1 USARTDIV and USART\_BRCF register configuration

Example 1:

If USARTDIV = 27.75, then:

$$\text{DIV\_Decimal} = 16 * 0.75 = 12 = 0x0C$$

$$\text{DIV\_Integer} = 27 = 0x1B$$

$$\text{So USART\_BRCF} = 0x1BC$$

Example 2:

If USARTDIV = 20.98, then:

$$\text{DIV\_Decimal} = 16 * 0.98 = 15.68$$

Nearest integer: DIV\_Decimal = 16 = 0x10, out of configurable range, so a carry to integer is required

$$\text{So DIV\_Integer} = 20 + 1 = 21 = 0x15$$

DIV\_Decimal = 0x0

So USART\_BRCF = 0x150

Example 3:

If USART\_BRCF = 0x19B:

DIV\_Integer = 0x19 = 25

DIV\_Decimal = 0x0B = 11

So USARTDIV =  $25 + 11/16 = 25.6875$

Table 23-3 Error calculation when setting baud rate

| Baud rate     |       | f <sub>PCLK</sub> =36MHz |                       |            | f <sub>PCLK</sub> =72MHz |                       |          |
|---------------|-------|--------------------------|-----------------------|------------|--------------------------|-----------------------|----------|
| serial number | Kbps  | reality                  | Set value in register | Error(%)   | reality                  | Set value in register | Error(%) |
| 1             | 2.4   | 2.4                      | 937.5                 | 0%         | 2.4                      | 1875                  | 0%       |
| 2             | 9.6   | 9.6                      | 234.375               | 0%         | 9.6                      | 468.75                | 0%       |
| 3             | 19.2  | 19.2                     | 117.1875              | 0%         | 19.2                     | 234.375               | 0%       |
| 4             | 57.6  | 57.6                     | 39.0625               | 0%         | 57.6                     | 78.125                | 0%       |
| 5             | 115.2 | 115.384                  | 19.5                  | 0.15%      | 115.2                    | 39.0625               | 0%       |
| 6             | 230.4 | 230.769                  | 9.75                  | 0.16%      | 230.769                  | 19.5                  | 0.16%    |
| 7             | 460.8 | 461.538                  | 4.875                 | 0.16%      | 461.538                  | 9.75                  | 0.16%    |
| 8             | 921.6 | 923.076                  | 2.4375                | 0.16%      | 923.076                  | 4.875                 | 0.16%    |
| 9             | 2250  | 2250                     | 1                     | 0%         | 2250                     | 2                     | 0%       |
| 10            | 4500  | impossible               | impossible            | impossible | 4500                     | 1                     | 0%       |

Notes: The lower the clock frequency of the CPU, the lower the error for a particular baud rate.

### 23.4.5 Receiver's tolerance clock deviation

Variations due to transmitter errors (including transmitter side oscillator variations), receiver side baud rate rounding errors, receiver side oscillator variations, variations due to transmission lines (usually due to The inconsistency between the low-to-high transition timing of the transceiver and the high-to-low transition timing of the transceiver), these factors will affect the overall clock system variation. Only when the sum of the above four changes is less than the tolerance of the USART receiver, the USART asynchronous receiver can work normally.

When receiving data normally, the tolerance of the USART receiver depends on the selection of the data bit length

and whether it is generated using a fractional baud rate. The tolerance of the USART receiver is equal to the maximum tolerable variation.

Table 23-4 when DIV\_Decimal = 0. Tolerance of USART receiver

| WL bit | NF is an error | NF is don't care |
|--------|----------------|------------------|
| 0      | 3.75%          | 4.375%           |
| 1      | 3.41%          | 3.97%            |

Table 23-5 when DIV\_Decimal != 0. Tolerance of USART receiver

| WL bit | NF is an error | NF is don't care |
|--------|----------------|------------------|
| 0      | 3.33%          | 3.88%            |
| 1      | 3.03%          | 3.53%            |

### 23.4.6 Parity control

Parity can be enabled by configuring the USART\_CTRL1.PCEN bit.

When the parity bit is enabled for transmission, A parity bit is generated, parity check is performed on reception.

Table 23-6 Frame format

| WL bit | PCEN bit | USART frame  |
|--------|----------|--|
| 0      | 0        | Start bit   8-bit data   Stop bit                  |
| 0      | 1        | Start bit   7 bits of data   Parity bit   Stop bit |
| 1      | 0        | Start bit   9-bit data   Stop bit                  |
| 1      | 1        | start bit   8-bit data   parity bit   stop bit     |

#### Even parity

Configure USART\_CTRL1.PSEL to 0, and even parity can be selected.

Make the number of '1' in the transmitted data (including parity bit) be an even number. That is: if Data=11000101, there are 4 '1's, then the parity bit will be '0' (4 '1' in total). After the data and check digit are sent to the receiver, the receiver calculates the number of 1s in the data again. If it is an even number, the check is passed, indicating that no errors occurred during the transmission process. If it is not even, it means that an error has occurred, the USART\_STS.PEF flag is set to '1', and if USART\_CTRL1.PEIE is enabled, an interrupt is generated.

#### Odd parity

Configure USART\_CTRL1.PSEL to 1, you can choose odd parity.

Make the number of '1' in the transmitted data (including parity bit) be an odd number. That is: if Data=11000101, there are 4 '1's, then the parity bit will be '1' (5 '1' in total). After the data and check digit are sent to the receiver, the receiver calculates the number of 1s in the data again. If it is an odd number, the check is passed, indicating that no errors occurred during the transmission process. If it is not an odd number, it means that an error has occurred, the USART\_STS.PEF flag is set to '1', and if USART\_CTRL1.PEIE is enabled, an interrupt is generated.

## 23.4.7 DMA application

The USART supports the DMA mode using multi-buffer configuration, which can realize high-speed data communication.

### 23.4.7.1 Using DMA transmission

Set USART\_CTRL3.DMATXEN to enable DMA mode when transmitting. When the USART's transmit shift register is empty (USART\_STS.TXDE=1), the DMA will transfer the data from the SRAM to the USART\_DAT register of the USART.

When using DMA transmission, the process of configuring the DMA channel is as follows:

1. Set the address of the data memory. When a data transfer request occurs, the transferred data will be read from this address.
2. Set the address of the USART\_DAT register. When a data transfer request occurs, this address will be the destination address of the data transfer.
3. Set the amount of data to transfer.
4. Set the priority of the channel, set whether to use the cyclic mode, the incremental mode of peripherals and memory, the data width of peripherals and memory, the interrupt generated by half of the transfer or the interrupt when the transfer is completed.
5. Start the channel.
6. After the data transfer is completed, the transfer complete flag (DMA\_INTSTS.TXCFx) is set to 1.

Figure 23-8 Transmission using DMA

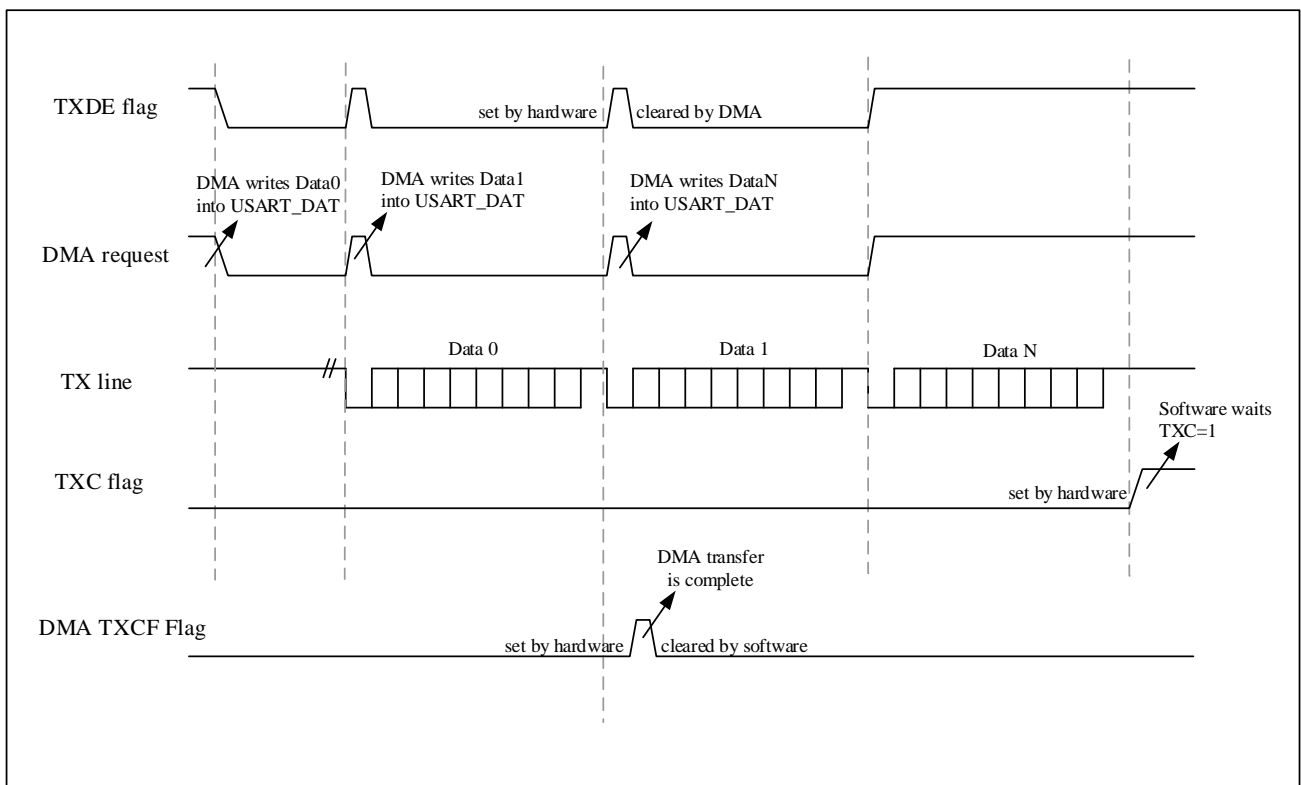

### 23.4.7.2 Using DMA reception

Set USART\_CTRL3.DMARXEN to enable DMA mode when receiving. When a byte is received

(USART\_STX.RXDNE=1), the DMA will transfer the data from the USART\_DAT register of the USART to the SRAM.

When using DMA reception, the process of configuring the DMA channel is as follows:

1. Set the address of the USART\_DAT register. When a data transfer request occurs, this address will be the source address of the data transfer.
2. Set the address of the data memory. When a data transfer request occurs, the transferred data will be written to this address.
3. Set the amount of data to transfer.
4. Set the priority of the channel, set whether to use the cyclic mode, the incremental mode of peripherals and memory, the data width of peripherals and memory, the interrupt generated by half of the transfer or the interrupt when the transfer is completed.
5. Start the channel.

Figure 23-9 Reception using DMA

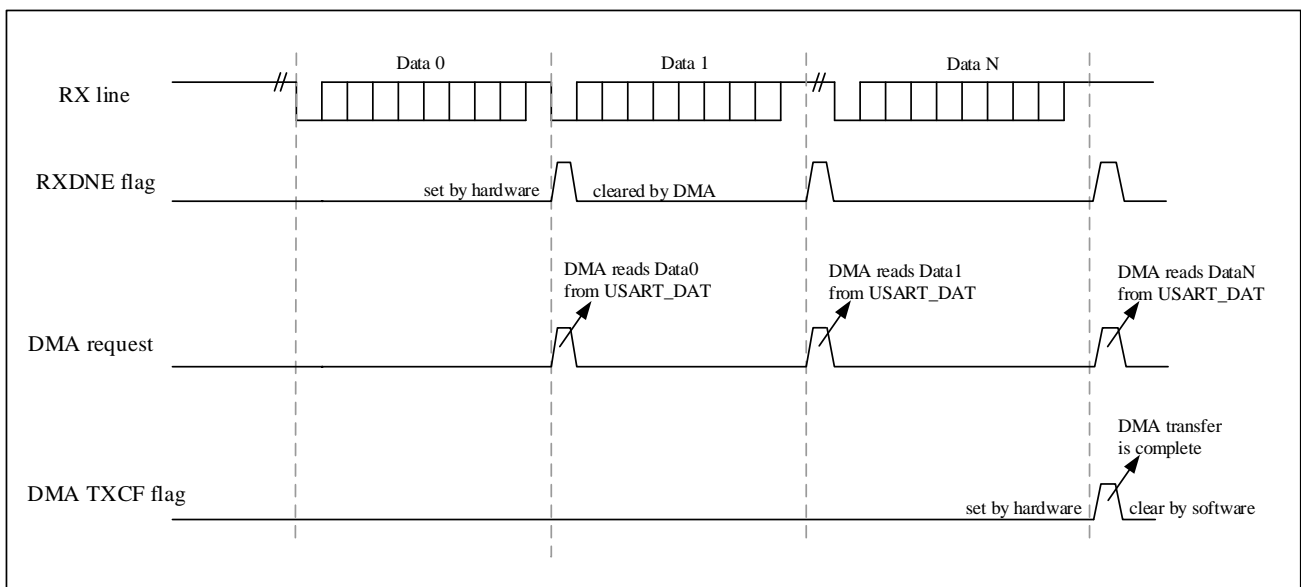

In multi-buffer communication mode, the error flag will be set when there is a frame error, overrun or noise error. An interrupt will be generated if the error interrupt is enabled (USART\_CTRL3.ERRIEN=1).

### 23.4.8 Hardware flow control

USART supports hardware flow control. The purpose is to coordinate the sending and receiving parties so that the data will not be lost. The connection method is shown in the following figure.

Figure 23-10 hardware flow control between two USART

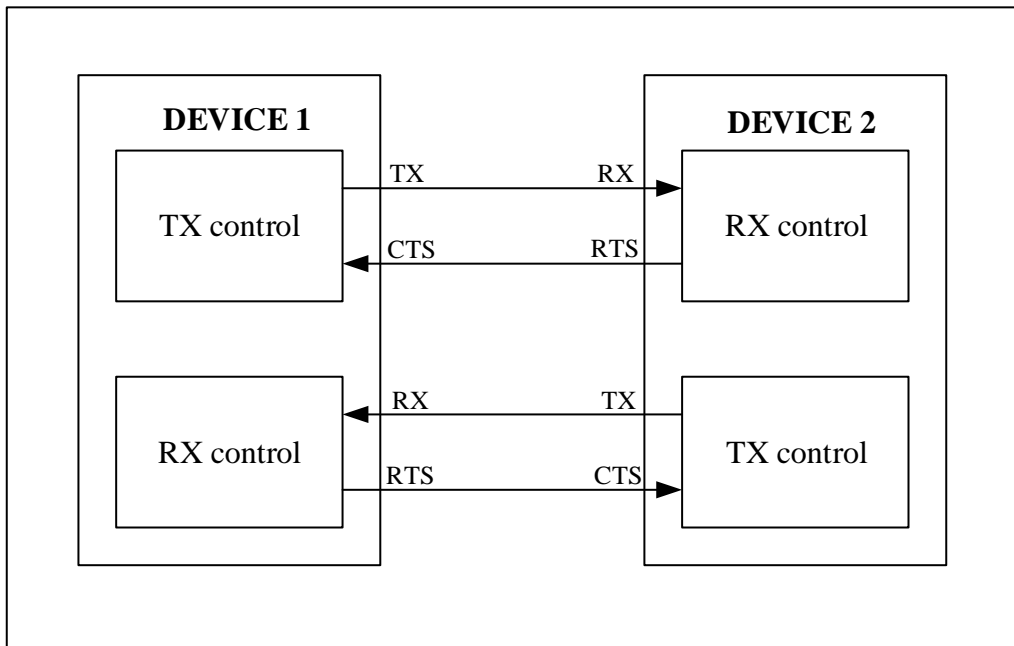

### 23.4.8.1 RTS flow control

Set `USART_CTRL3.RTSSEN` to enable RTS. RTS is the output signal used to indicate that the receiver is ready. When data arrives in RDR, pull high `nRTS` output, notifying the sender to stop data transmission at the end of the current frame. when receiver is ready to receive new data, assert (pull low) the `nRTS` output.

Figure 23-11 RTS flow control

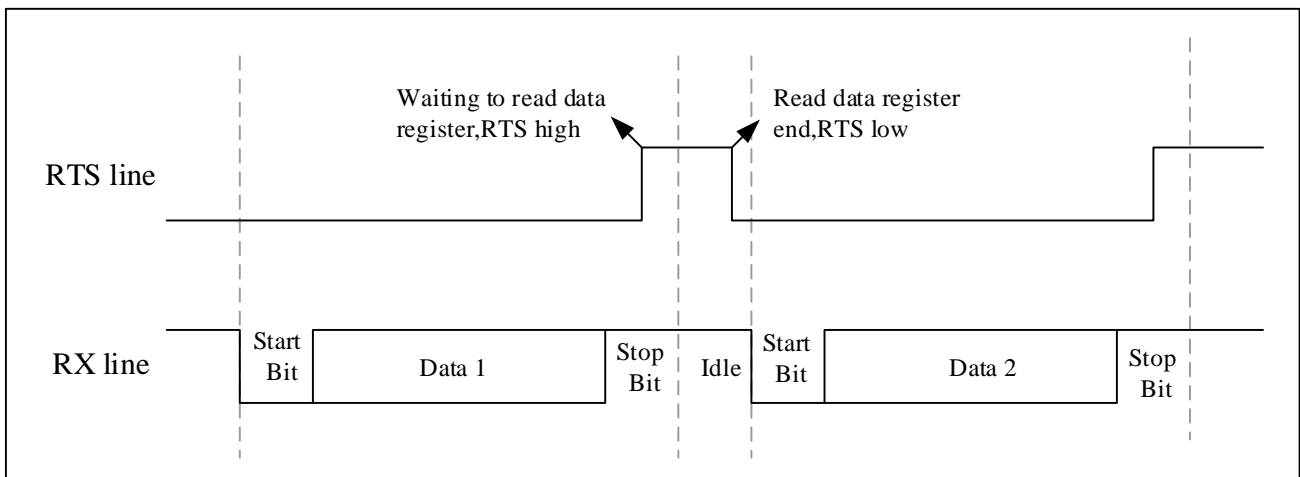

### 23.4.8.2 CTS flow control

Set `USART_CTRL3.CTSSEN` to enable CTS. CTS is an input signal, used to judge whether data can be sent to the other device. The low level is valid, and the low level indicates that the device can send data to the other device. If the `nCTS` signal becomes invalid during data transmission, the transmission will stop after sending the data. If you write data to the data register when `nCTS` is invalid, the data will not be sent until `nCTS` is valid.

If the `USART_CTRL3.CTSSEN` bit is set, the `USART_STS.CTSF` bit will be set high by hardware when the `nCTS` input changes state. An interrupt will be generated if `USART_CTRL3.CTSIEN` is enabled.

Figure 23-12 CTS flow controls

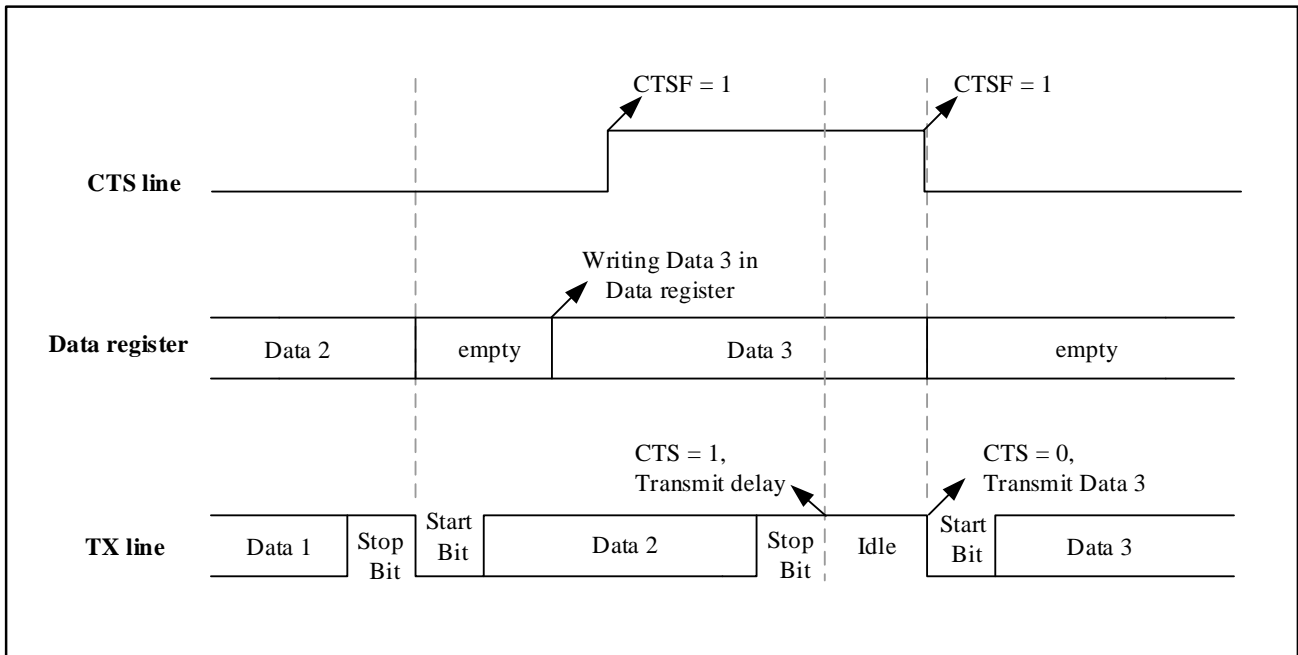

## 23.4.9 Multiprocessor communication

USART allows multiprocessor communication. The principle is: multiple processors communicate through USART, and it is necessary to determine who is the master device, and the remaining processors are all slave devices. The TX output of the master device is directly connected to the RX port of all slave device. The TX outputs of the slaves are logically AND together and connected to the RX inputs of the master.

When multi-processor communication is performed, the slave devices are all in mute mode, and the host uses a specific method to wake up a slave device to be communicated when needed, so that the slave device is in an active state and transmits data with the master device.

The USART can wake up from mute mode by idle line detection or address mark detection.

### 23.4.9.1 Idle line detection

The idle line detection configuration process is as follows:

1. Configure the USART\_CTRL1.WUM bit to 0, and the USART performs idle line detection;
2. When USART\_CTRL1.RCVWU is set (which can be automatically controlled by hardware or written by software under certain conditions), USART enters mute mode. In mute mode, none of the receive status bits are set, and all receive interrupts are disabled;
3. As shown in the Figure 23-13 below, when an idle frame is detected, USART is woken up, and then USART\_CTRL1.RCVWU is cleared by hardware. At this time, USART\_STS.IDLEF is not set.

Figure 23-13 Mute mode using idle line detection

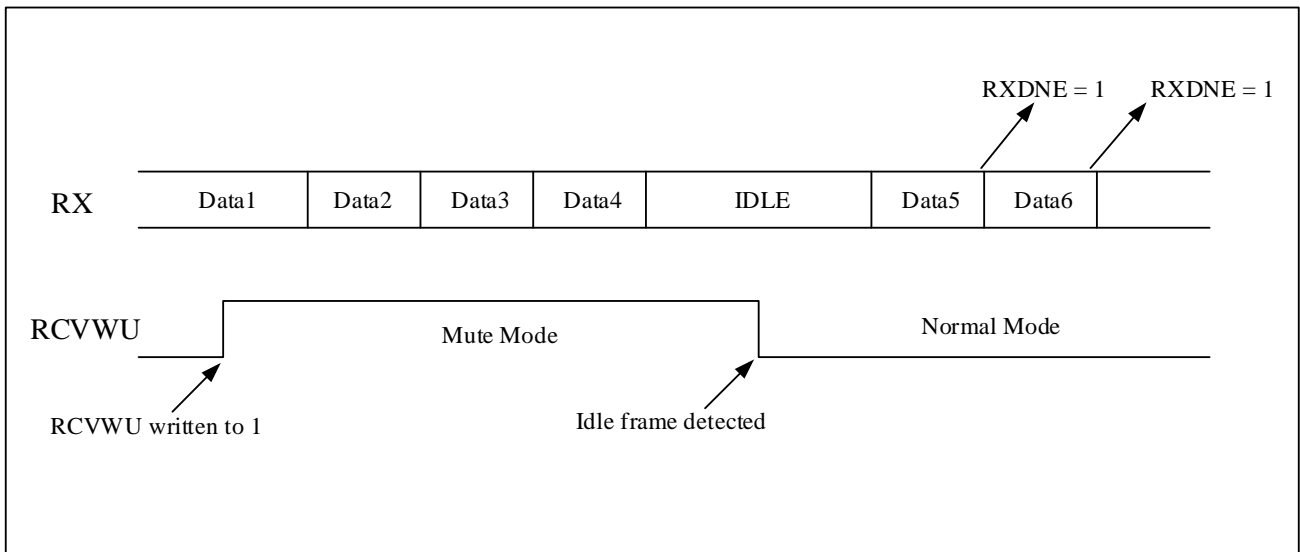

### 23.4.9.2 Address mark detection

By configuring the `USART_CTRL1.WUM` bit to 1, the USART performs address mark detection. The address of the receiver is programmable through the `USART_CTRL2.ADDR[3:0]` bits. If the MSB is 1, the byte is considered an address, otherwise it is considered data.

In this mode, the USART can enter mute mode by:

- When the receiver does not contain data, `USART_CTRL1.RCVWU` can be written to 1 by software, and USART enters mute mode;

*Note: When the receive buffer contains no data (`RXNE=0` in `USART_SR`), the `USART_CTRL1.RCVWU` bit can be written to 0 or 1. Otherwise, the write operation is ignored.*

- When the received address does not match the address of the `USART_CTRL2.ADDR[3:0]` bits, `USART_CTRL1.RCVWU` is written to 1 by hardware.

In mute mode, none of the receive status bits are set and all receive interrupts are disabled.

When the received address matches the address of the `USART_CTRL2.ADDR[3:0]` bits, the USART is woken up and `USART_CTRL1.RCVWU` is cleared. The `USART_STS.RXDNE` bit will be set when this matching address is received. Data can then be transmitted normally.

Figure 23-14 Mute mode detected using address mark

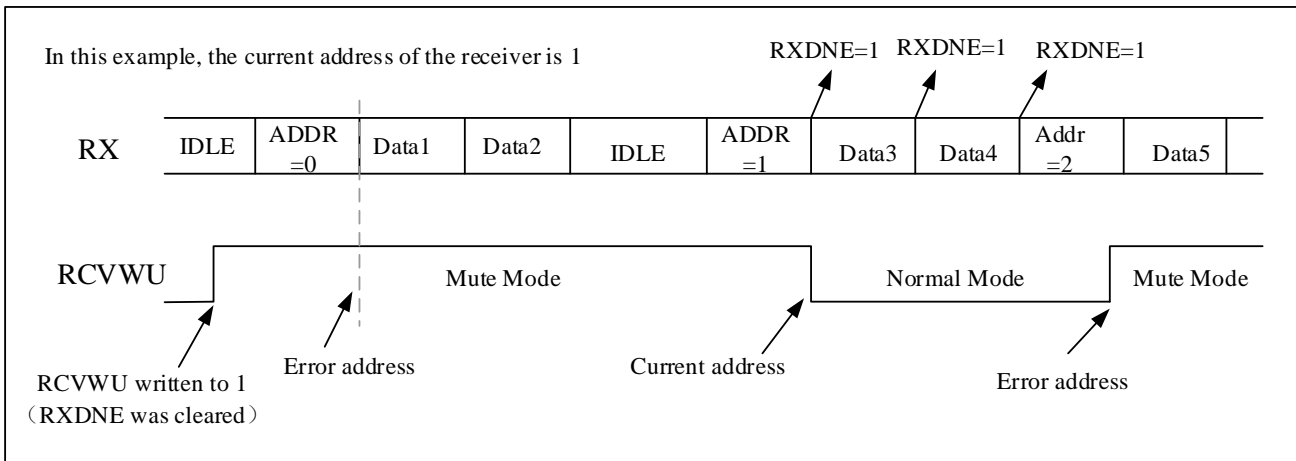

### 23.4.10 Synchronous mode

USART supports synchronous serial communication. The USART only supports the master mode, and cannot use the input clock from other devices to receive and transmit data. Synchronous mode can be enabled by configuring the USART\_CTRL2.CLKEN bit.

*Note: When using synchronous mode, USART\_CTRL2.LINMEN, USART\_CTRL3.SCMEN, USART\_CTRL3.HDMEN, USART\_CTRL3.IRDAMEN, these bits need to be kept clear.*

#### 23.4.10.1 Synchronized clock

The CK pin is the output of the USART transmitter clock. During the bus idle period, before the actual data arrives and when the break symbol is sent, the clock not output.

Clock phase and polarity are software programmable and need to be configured when both the transmitter and receiver are disabled. When the clock polarity is 0 (USART\_CTRL2.CLKPOL=0), the default level of CLK is low; when the clock polarity is 1 (USART\_CTRL2.CLKPOL=1), the default level of CLK is high. When the phase polarity is 0 (USART\_CTRL2.CLKPHA=0), the data is sampled on the first edge of the clock; when the phase polarity is 1 (USART\_CTRL2.CLKPHA=1), the data is sampled on the second edge.

During the start and stop bits, the CK pin does not output clock pulses.

A sync data cannot be received when no data is sent. Because the clock is only available when the transmitter is activated and data is written to the USART\_DAT register.

The USART\_CTRL2.LBCLK bit controls whether to output the clock pulse corresponding to the last data byte (MSB) sent on the CK pin. This bit needs to be configured when both the transmitter and receiver are disabled. If USART\_CTRL2.LBCLK is 1, the clock pulse of the last bit of data will be output from CK. If USART\_CTRL2.LBCLK is 0, the clock pulse of the last bit of data is not output from CK.

#### 23.4.10.2 Synchronized transmitting

The transmitter in synchronous mode works the same as in asynchronous mode. Data on the TX pin is sent out synchronously with CK.

### 23.4.10.3 Synchronized receiving

The receiver in synchronous mode works differently than in asynchronous mode. Data is sampled on CK without any oversampling. But setup time and hold time (depending on baud rate, 1/16 bit time) must be considered.

Figure 23-15 USART synchronous transmission example

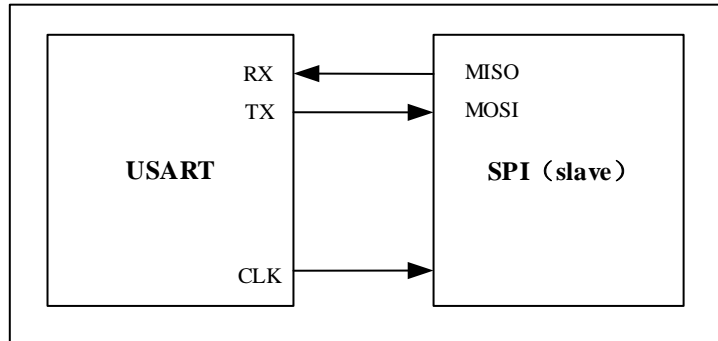

Figure 23-16 USART data clock timing example (WL=0)

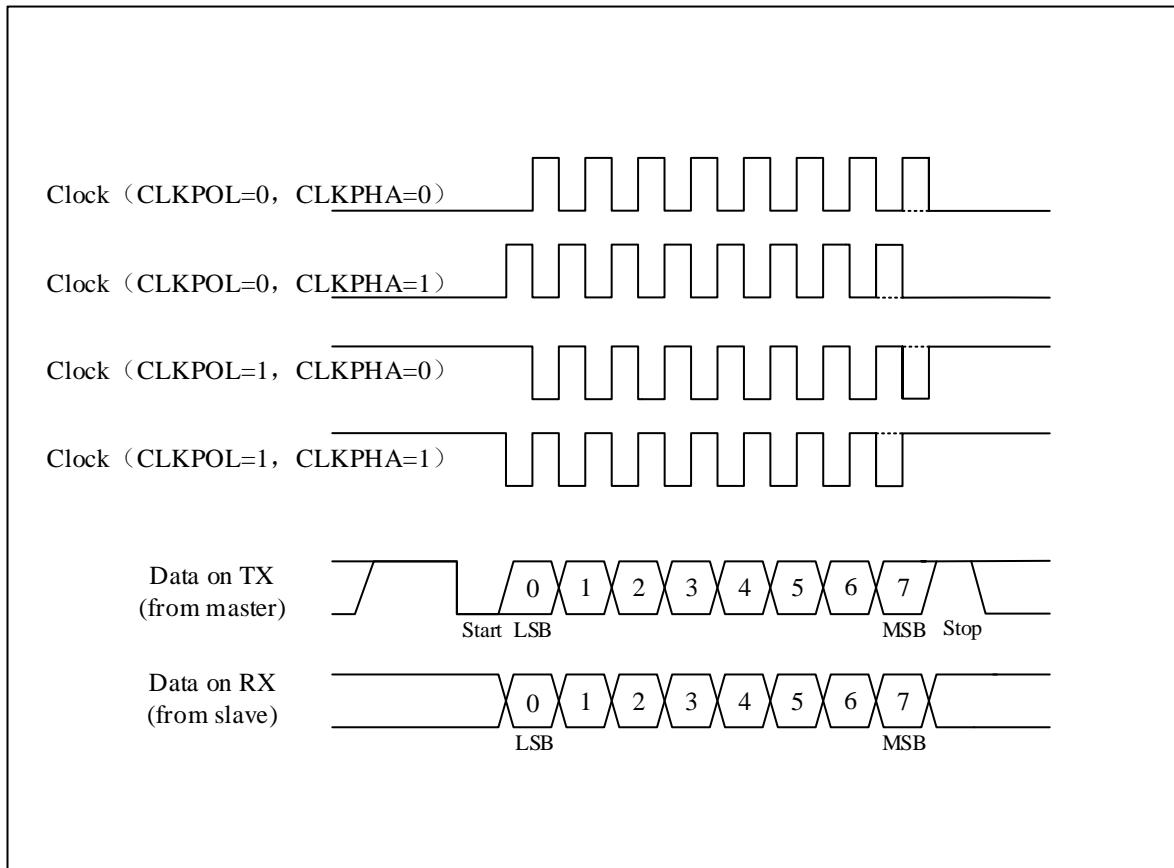

Figure 23-17 USART data clock timing example (WL=1)

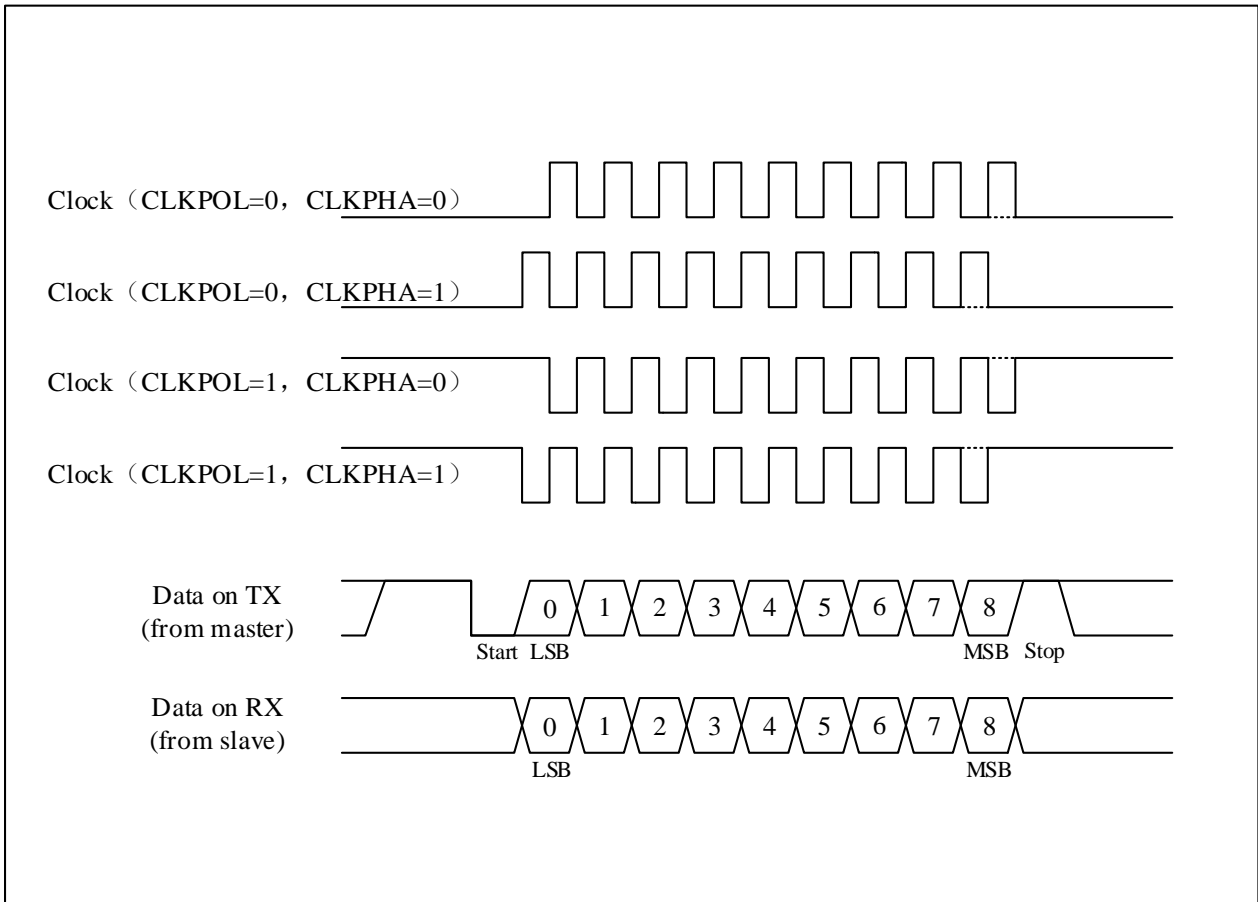
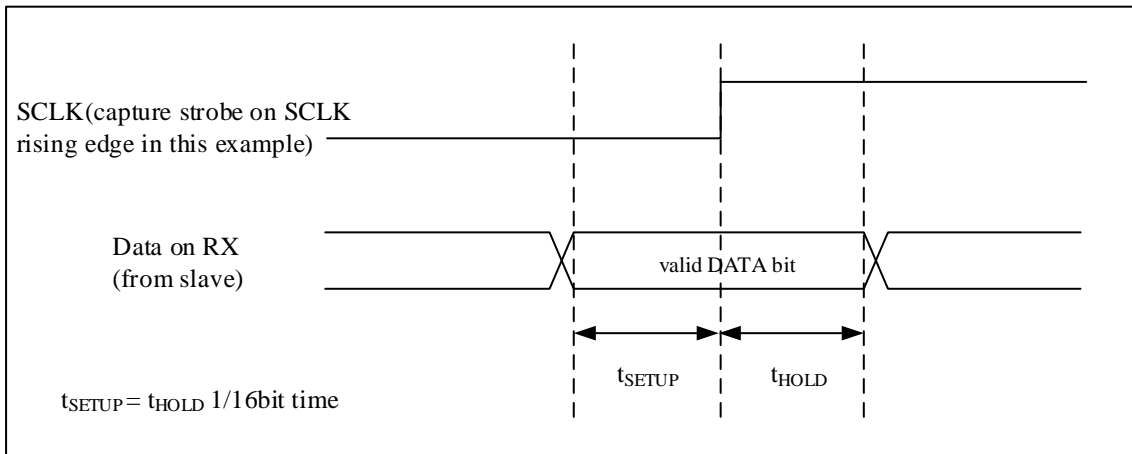

Figure 23-18 RX data sampling / holding time



Note: the function of CK is different in Smartcard mode, please refer to the Smartcard mode section for details.

### 23.4.11 Single-wire half-duplex mode

USART supports single-wire half-duplex communication, allowing data to be transmitted in both directions, but only allows data to be transmitted in one direction at the same time. Communication conflicts are managed by software.

Through the USART\_CTRL3.HDMEN bit, you can choose whether to enable half-duplex mode. When using single-

wire half-duplex, USART\_CTRL2.CLKEN, USART\_CTRL2.LINMEN, USART\_CTRL3.SCMEN, USART\_CTRL3.IRDAMEN, these bits should be kept clear.

After the half-duplex mode is turned on, the TX pin and the RX pin are interconnected inside the chip, and the Rx pin is no longer used. When there is no data to transmit, TX is always released. Therefore, when not driven by the USART, the TX pin must be configured as a floating input or an open-drain output high.

### 23.4.12 IrDA SIR ENDEC mode

USART supports the IrDA (Infrared Data Association) SIR ENDEC specification.

Through the USART\_CTRL3.IRDAMEN bit, you can choose whether to enable the infrared mode. When using the infrared function, USART\_CTRL2.CLKEN, USART\_CTRL2.STPB[1:0], USART\_CTRL2.LINMEN, USART\_CTRL3.HDMEN, USART\_CTRL3.SCMEN, these bits should be kept clear.

Through the USART\_CTRL3.IRDALP bit, it can be used to select normal mode or low power infrared mode.

#### 23.4.12.1 IrDA normal mode

When USART\_CTRL3.IRDALP=0, select normal infrared mode.

IrDA is a half-duplex communication protocol, so there should be a minimum delay of 10ms between sending and receiving, that uses an inverted return-to-zero modulation scheme (RZI), which uses an infrared light pulse to represent a logic '0', and the pulse width is specified as 3/16 of a bit period in normal mode, as shown in the Figure 23-20. USART only supports up to 115200bps for SIR ENDEC.

The USART sends data to the SIR encoder, and the bit stream output by the USART will be modulated. A modulated stream of pulses is sent from the infrared transmitter and then received by the infrared receiver. The SIR receiver decoder demodulates it and outputs the data to the USART.

The transmit encoder output has opposite polarity to the decoder input. When idle, SIR transmit is low, while SIR receive is high. The high pulse sent by SIR is '0' and the low level is '1', while SIR reception is the opposite.

If the USART is sending data to the IrDA transmit encoder, then the IrDA receive decoder will ignore any data on the IrDA receive line. If the USART is receiving data sent from the SIR receiver decoder, the data sent by the USART to the IrDA transmitter encoder will not be encoded.

Pulse width is programmable. The IrDA specification requires pulses to be wider than 1.41us. For pulse widths less than 2 cycles, the receiver will filter them out. PSCV is the prescaler value programmed in the USART\_GTP register.

#### 23.4.12.2 IrDA low power mode

When USART\_CTRL3.IRDALP=1, select low power infrared mode.

For the transmitter, when in low power mode, the pulse width is 3 times the low power baud rate, which is a minimum of 1.42MHz. Typically this value is 1.8432MHz ( $1.42 \text{ MHz} < \text{PSC} < 2.12 \text{ MHz}$ ).

For the receiver, the requirement for a valid signal is that the duration of the low level signal must be greater than 2 cycles of the IrDA low power baud rate clock.

Figure 23-19 IrDASIRENDEC-Block diagram

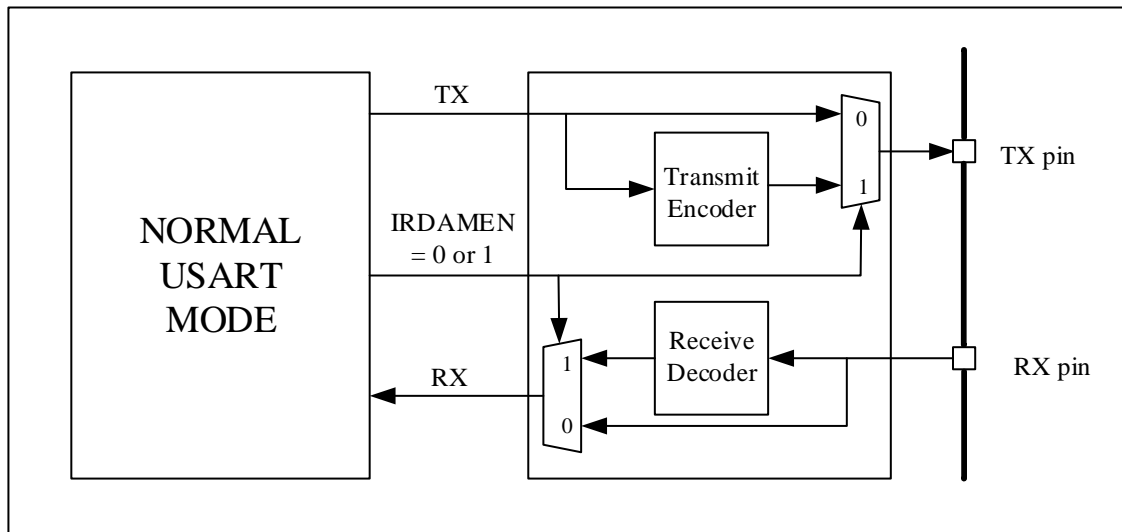
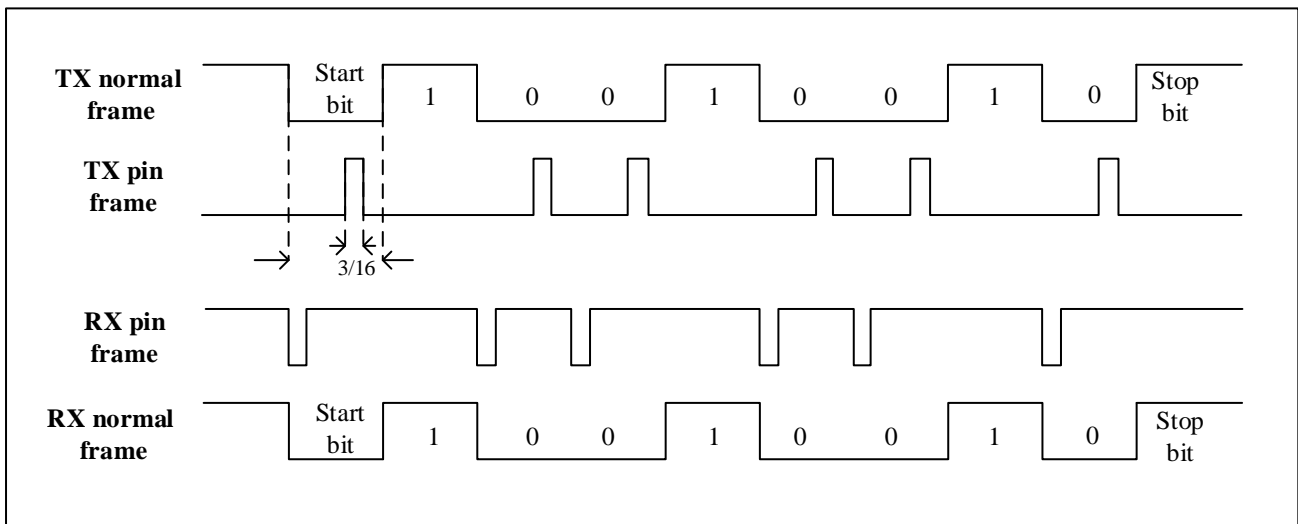

Figure 23-20 IrDA data Modulation (3/16)-normal mode



### 23.4.13 LIN mode

USART supports the ability of a LIN(Local interconnection Network) master to send a synchronization break and the ability of a LIN slave to detect a break. LIN mode can be enabled by configuring the USART\_CTRL2.LINMEN bit.

*Note: When using LIN mode, USART\_CTRL2.STPB[1:0], USART\_CTRL2.CLKEN, USART\_CTRL3.SCMEN, USART\_CTRL3.HDMEN, USART\_CTRL3.IRDAMEN, these bits should be kept clear.*

#### 23.4.13.1 LIN transmitting

When LIN is sent, the length of the data bits sent can only be 8 bits. By setting USART\_CTRL1.SDBRK, a 13-bit '0' will be sent as the break symbol, and insert a stop bit.

#### 23.4.13.2 LIN receiving

Whether the bus is idle or during the transmission of a data frame, as long as the break frame appears, it can be detected. the break symbol detection is independent of the USART receiver.

By configuring the USART\_CTRL2.LINBDL bit, 10-bit or 11-bit break character detection can be selected.

After the receiver detects the start bit, the circuit samples each subsequent bit at the 8th, 9th, and 10th oversampling clock points of each bit. When 10 or 11 consecutive bits are detected as '0' and followed by a delimiter, it means that a LIN break is detected, and USART\_STS.LINBDF is set. Before confirming the break symbol, check the delimiter as it means the RX line has gone back to high. An interrupt is generated if the LIN breaker detection interrupt (USART\_CTRL2.LINBDIEN) is enabled.

If a '1' is sampled before the 10th or 11th sample point, the current detection is canceled and the start bit is searched again.

Figure 23-21 Break detection in LIN mode (11-bit break length-the LINBDL bit is set)

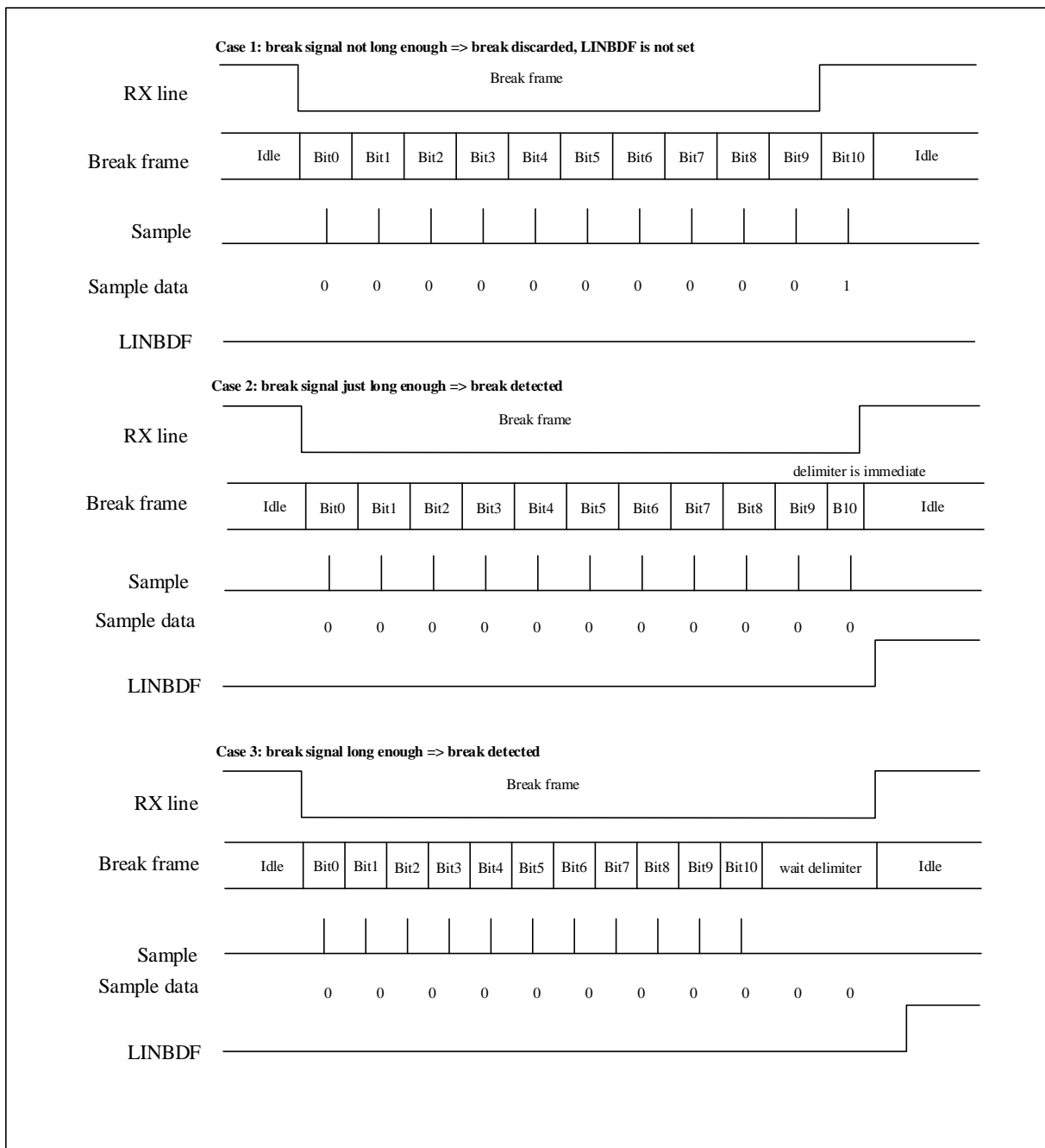
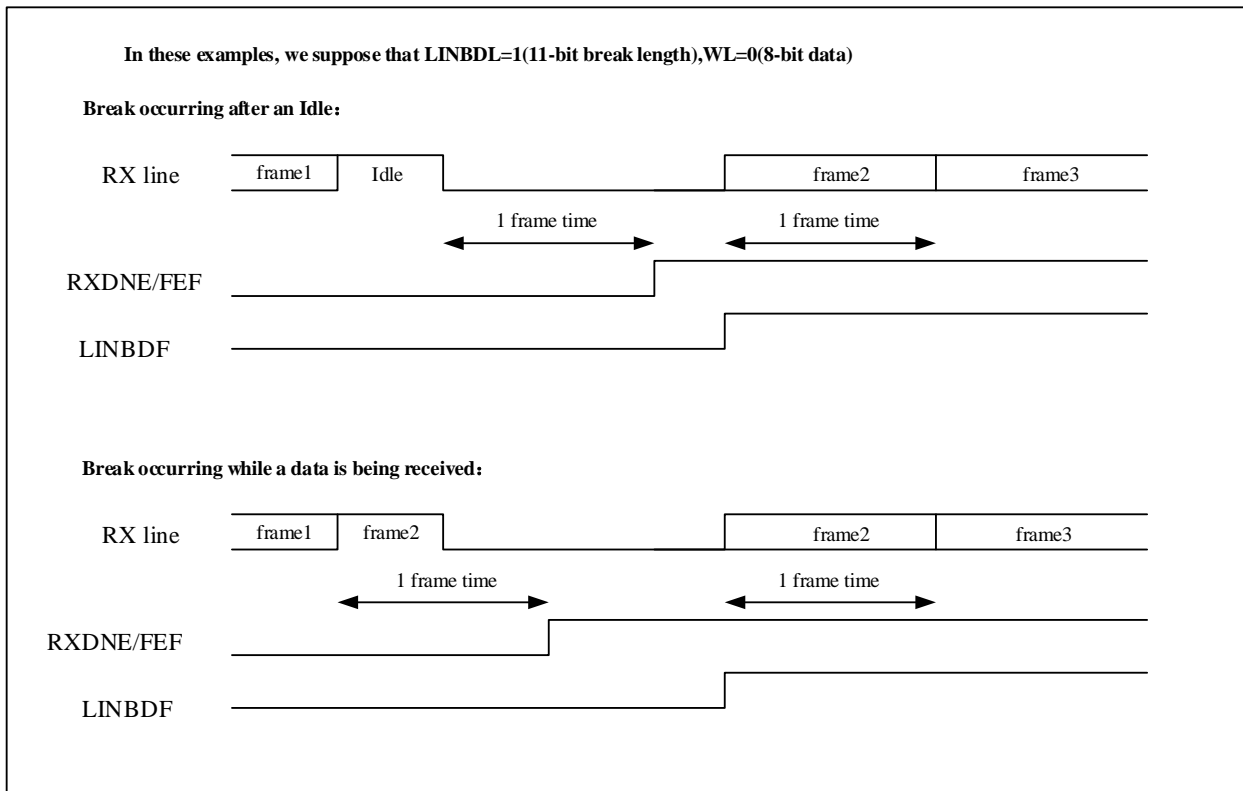

Figure 23-22 Break detection and framing error detection in LIN mode



### 23.4.14 Smartcard mode (ISO7816)

USART supports smart card protocol. The smart card interface supports the asynchronous smart card protocol defined in the ISO7816-3 standard.

Through the USART\_CTRL3.SCMEN bit, you can choose whether to enable smart card mode. When using smart card mode, USART\_CTRL2.LINMEN, USART\_CTRL3.HDMEN, USART\_CTRL3.IRDAMEN, these bits should be kept clear.

In smart card mode, the USART can provide a clock through the CK pin. The system clock is divided by the prescaler register to provide the clock to the smart card. The CK frequency can be from  $f_{CK}/2$  to  $f_{CK}/62$ , where  $f_{CK}$  is the peripheral input clock.

In smart card mode, 0.5 and 1.5 stop bits can be used when receiving data, and only 1.5 stop bits can be used when sending data. So 1.5 stop bits are recommended as this avoids configuration transitions.

In smart card mode, the data bits should be configured as 8 bits, and the parity bit should be configured.

When a parity error is detected by receiver, the transmit data line is pulled low for one baud clock cycle at the end of the stop bit as NACK signal (if USART\_CTRL3.SCNAK is set). This NACK signal will generate a framing error on the transmit side (transmit side is configured with 1.5 stop bits).

When the transmitter receives a NACK signal (framing error) from the receiver, it does not detect the NACK as a start bit (according to the ISO protocol, the duration of the received NACK can be 1 or 2 baud clock cycles).

The example given in the following figure illustrates the signal on the data line with and without parity errors.

Figure 23-23 ISO7816-3 Asynchronous Protocol

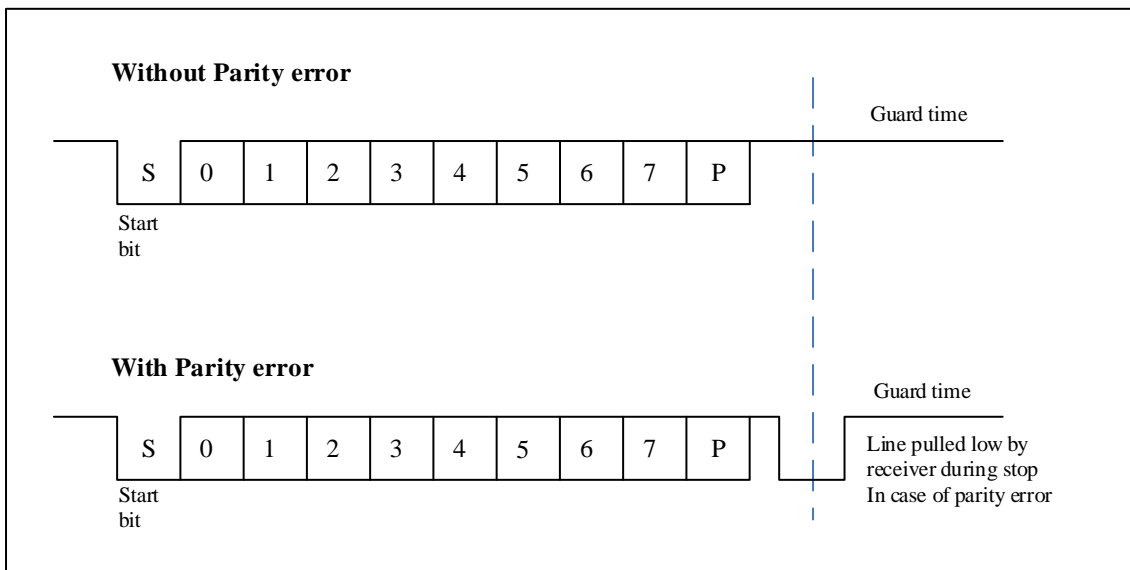

The break frame has no meaning in smart card mode. A 00h data with a framing error will be treated as data instead of a break symbol.

Under normal operation, data will be shifted out of the transmit shift register on the next baud clock. The smart card mode is delayed by a minimum of 1/2 baud clock than normal operation.

In normal operation, USART\_STS.TXC is set when a frame containing data is sent and USART\_STS.TXDE=1. In smart card mode, the transmission completion flag (USART\_STS.TXC) is set high when the guard time counter reaches the value (USART\_GTP.GTV[7:0]). The clearing of the USART\_STS.TXC flag is not affected by the smart card mode.

The following figure details how USART samples NACK signals.

Figure 23-24 Use 1.5 stop bits to detect parity errors

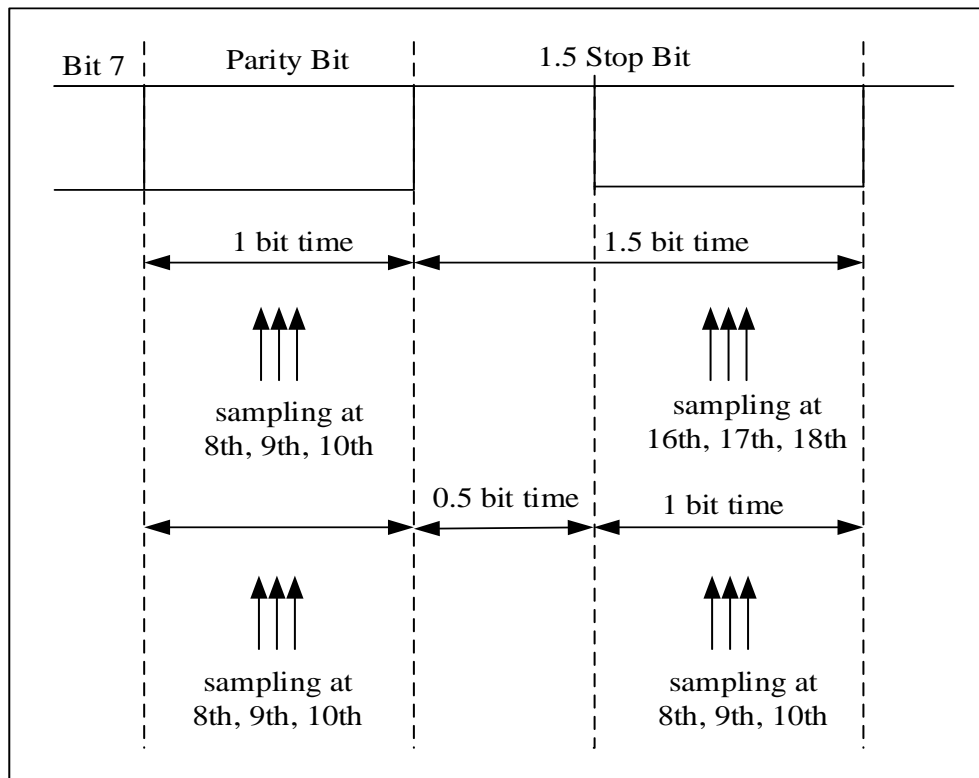

## 23.5 Interrupt request

The various interrupt events of USART are logical OR relations, if the corresponding enable control bit is set, these events can generate their own interrupts, but only one interrupt request can be generated at the same time.

Table 23-7 USART interrupt request

| Interrupt function     | Interrupt event  | Event flag   | Enable bit            |
|------------------------|--|--------------|-----------------------|
| USART global interrupt | Transmission data register is empty.                                 | TXDE         | TXDEIEN               |
|                        | CTS flag   | CTSF         | CTSIEN                |
|                        | Transmission complete  | TXC          | TXCIEN                |
|                        | Receive data ready to be read  | RXDNE        | RXDNEIEN              |
|                        | Data overrun error detected.   | ORERR        |                       |
|                        | Idle line detected   | IDLEF        | IDLEIEN               |
|                        | Parity error   | PEF          | PEIEN                 |
|                        | Disconnect flag  | LINBDF       | LINBDIEN              |
|                        | Noise, overrun error and framing error in multi-buffer communication | NEF/OREF/FEF | ERRIEN <sup>(1)</sup> |

(1) This flag bit is used only when DMA is used to receive data(USART\_CTRL3.DMARXEN=1).

## 23.6 Mode support

Table 23-8 USART mode setting <sup>(1)</sup>

| Communication mode           | USART1 | USART2 | USART3 | UART4 | UART5 | UART6 | UART7 |
|------------------------------|--------|--------|--------|-------|-------|-------|-------|
| Asynchronous mode            | Y      | Y      | Y      | Y     | Y     | Y     | Y     |
| Multiprocessor               | Y      | Y      | Y      | Y     | Y     | Y     | Y     |
| LIN mode                     | Y      | Y      | Y      | Y     | Y     | Y     | Y     |
| Synchronous mode             | Y      | Y      | Y      | N     | N     | N     | N     |
| Single-wire half duplex mode | Y      | Y      | Y      | Y     | Y     | Y     | Y     |
| Smartcard mode               | Y      | Y      | Y      | N     | N     | N     | N     |
| IrDA infrared mode           | Y      | Y      | Y      | Y     | Y     | Y     | Y     |
| DMA communication mode       | Y      | Y      | Y      | Y     | Y     | Y     | Y     |
| Hardware flow control mode   | Y      | Y      | Y      | N     | N     | N     | N     |

(1) Y = support this mode, N = do not support this mode

## 23.7 USART registers

### 23.7.1 USART register overview

Table 23-9 USART register overview

| Offset | Register    | 31       | 30 | 29 | 28 | 27 | 26 | 25 | 24 | 23 | 22 | 21 | 20 | 19 | 18 | 17                | 16         | 15    | 14     | 13     | 12    | 11       | 10       | 9                 | 8        | 7         | 6      | 5        | 4       | 3    | 2    | 1     | 0     |   |   |   |   |   |   |   |   |   |   |   |   |   |   |   |   |   |   |   |   |   |   |   |
|--------|-------------|----------|----|----|----|----|----|----|----|----|----|----|----|----|----|-------------------|------------|-------|--------|--------|-------|----------|----------|-------------------|----------|-----------|--------|----------|---------|------|------|-------|-------|---|---|---|---|---|---|---|---|---|---|---|---|---|---|---|---|---|---|---|---|---|---|---|
| 000h   | USART_STS   | Reserved |    |    |    |    |    |    |    |    |    |    |    |    |    |                   |            |       |        |        |       |          |          | CTS               | LNBDL    | TXDE      | TXC    | RXDNE    | IDLEF   | OREF | NEF  | FEF   | PEF   |   |   |   |   |   |   |   |   |   |   |   |   |   |   |   |   |   |   |   |   |   |   |   |
|        | Reset Value |          |    |    |    |    |    |    |    |    |    |    |    |    |    |                   |            |       |        |        |       |          |          | 0                 | 0        | 1         | 1      | 0        | 0       | 0    | 0    | 0     | 0     | 0 | 0 | 0 | 0 | 0 | 0 | 0 | 0 | 0 | 0 | 0 | 0 | 0 | 0 | 0 | 0 | 0 | 0 | 0 | 0 | 0 | 0 | 0 |
| 004h   | USART_DAT   | Reserved |    |    |    |    |    |    |    |    |    |    |    |    |    |                   |            |       |        |        |       |          |          | DATV[8:0]         |          |           |        |          |         |      |      |       |       |   |   |   |   |   |   |   |   |   |   |   |   |   |   |   |   |   |   |   |   |   |   |   |
|        | Reset Value |          |    |    |    |    |    |    |    |    |    |    |    |    |    |                   |            |       |        |        |       |          |          | 0                 | 0        | 0         | 0      | 0        | 0       | 0    | 0    | 0     | 0     | 0 | 0 | 0 | 0 | 0 | 0 | 0 | 0 | 0 | 0 | 0 | 0 | 0 | 0 | 0 | 0 | 0 | 0 | 0 | 0 | 0 | 0 | 0 |
| 008h   | USART_BRCF  | Reserved |    |    |    |    |    |    |    |    |    |    |    |    |    | DIV_Integer[11:0] |            |       |        |        |       |          |          | DIV_Decimal [3:0] |          |           |        |          |         |      |      |       |       |   |   |   |   |   |   |   |   |   |   |   |   |   |   |   |   |   |   |   |   |   |   |   |
|        | Reset Value |          |    |    |    |    |    |    |    |    |    |    |    |    |    | 0                 | 0          | 0     | 0      | 0      | 0     | 0        | 0        | 0                 | 0        | 0         | 0      | 0        | 0       | 0    | 0    | 0     | 0     | 0 | 0 | 0 | 0 | 0 | 0 | 0 | 0 | 0 | 0 | 0 | 0 | 0 | 0 | 0 | 0 | 0 |   |   |   |   |   |   |
| 00Ch   | USART_CTRL1 | Reserved |    |    |    |    |    |    |    |    |    |    |    |    |    |                   |            |       |        | UEN    | WL    | WUM      | PCEN     | PSEL              | PEIEN    | TXDEIEN   | TXCIEN | RXDNEIEN | IDLEIEN | TXEN | RXEN | RCVWU | SDBRK |   |   |   |   |   |   |   |   |   |   |   |   |   |   |   |   |   |   |   |   |   |   |   |
|        | Reset Value |          |    |    |    |    |    |    |    |    |    |    |    |    |    |                   |            |       |        | 0      | 0     | 0        | 0        | 0                 | 0        | 0         | 0      | 0        | 0       | 0    | 0    | 0     | 0     | 0 | 0 | 0 | 0 | 0 | 0 | 0 | 0 | 0 | 0 | 0 | 0 | 0 | 0 | 0 | 0 | 0 | 0 | 0 | 0 | 0 | 0 | 0 |
| 010h   | USART_CTRL2 | Reserved |    |    |    |    |    |    |    |    |    |    |    |    |    | LINMEN            | STPB [1:0] | CLKEN | CLKPOL | CLKPHA | LBCLK | Reserved | LINBDIEN | LINBDL            | Reserved | ADDR[3:0] |        |          |         |      |      |       |       |   |   |   |   |   |   |   |   |   |   |   |   |   |   |   |   |   |   |   |   |   |   |   |

| Offset | Register    | 31       | 30 | 29 | 28 | 27 | 26 | 25 | 24 | 23 | 22 | 21 | 20 | 19 | 18       | 17 | 16 | 15 | 14 | 13 | 12 | 11        | 10    | 9     | 8     | 7       | 6       | 5     | 4      | 3     | 2      | 1       | 0      |   |   |   |   |   |   |   |   |   |   |   |   |   |   |   |   |   |   |   |
|--------|-------------|----------|----|----|----|----|----|----|----|----|----|----|----|----|----------|----|----|----|----|----|----|-----------|-------|-------|-------|---------|---------|-------|--------|-------|--------|---------|--------|---|---|---|---|---|---|---|---|---|---|---|---|---|---|---|---|---|---|---|
|        | Reset Value |          |    |    |    |    |    |    |    |    |    |    |    |    |          |    |    |    |    | 0  | 0  | 0         | 0     | 0     | 0     | 0       | 0       | 0     | 0      | 0     | 0      | 0       | 0      | 0 | 0 | 0 | 0 | 0 | 0 | 0 | 0 | 0 | 0 | 0 | 0 | 0 | 0 | 0 | 0 | 0 | 0 |   |
| 014h   | USART_CTRL3 | Reserved |    |    |    |    |    |    |    |    |    |    |    |    |          |    |    |    |    |    |    |           | CTSIE | CTSEN | RTSEN | DMATXEN | DMARXEN | SCMEN | SCNACK | HDMEN | IRDALP | IRDAVEN | ERRIEN |   |   |   |   |   |   |   |   |   |   |   |   |   |   |   |   |   |   |   |
|        | Reset Value |          |    |    |    |    |    |    |    |    |    |    |    |    |          |    |    |    |    |    |    |           | 0     | 0     | 0     | 0       | 0       | 0     | 0      | 0     | 0      | 0       | 0      | 0 | 0 | 0 | 0 | 0 | 0 | 0 | 0 | 0 | 0 | 0 | 0 | 0 | 0 | 0 | 0 | 0 | 0 | 0 |
| 018h   | USART_GTP   | Reserved |    |    |    |    |    |    |    |    |    |    |    |    | GTV[7:0] |    |    |    |    |    |    | PSCV[7:0] |       |       |       |         |         |       |        |       |        |         |        |   |   |   |   |   |   |   |   |   |   |   |   |   |   |   |   |   |   |   |
|        | Reset Value |          |    |    |    |    |    |    |    |    |    |    |    |    | 0        | 0  | 0  | 0  | 0  | 0  | 0  | 0         | 0     | 0     | 0     | 0       | 0       | 0     | 0      | 0     | 0      | 0       | 0      | 0 | 0 | 0 | 0 | 0 | 0 | 0 | 0 | 0 | 0 | 0 | 0 | 0 |   |   |   |   |   |   |

### 23.7.2 USART Status register (USART\_STS)

Address offset : 0x00

Reset value : 0x0000 00C0

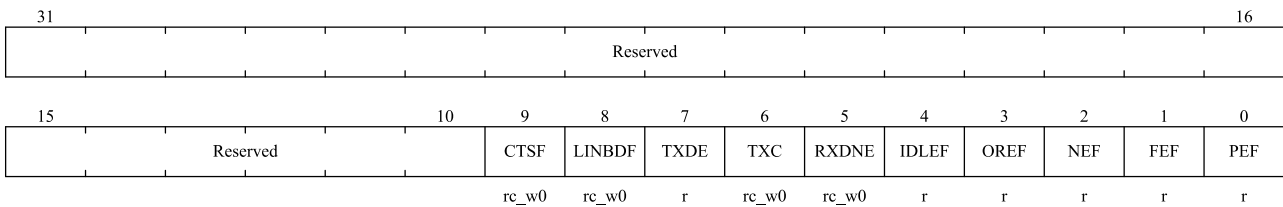

| Bit field | Name     | Description   |
|-----------|----------|---|
| 31:10     | Reserved | Reserved, the reset value must be maintained  |
| 9         | CTSF     | CTS flag<br>If USART_CTRL3.CTSEN bit is set, this bit is set by hardware when the nCTS input changes. If USART_CTRL3.CTSIEN bit is set, an interrupt will be generated.<br>This bit is cleared by software.<br>0:nCTS status line has not changed.<br>1:nCTS status line changes.<br><i>Note: This bit is invalid for UART4/5/6/7.</i>                        |
| 8         | LINBDF   | LIN break detection flag.<br>If USART_CTRL2.LINMEN bit is set, this bit is set by hardware when LIN disconnection is detected. If USART_CTRL2.LINBDIEN bit is set, an interrupt will be generated.<br>This bit is cleared by software.<br>0: LIN break character not detected.<br>1: LIN break character detected.  |
| 7         | TXDE     | The Transmit data register empty.<br>Set to 1 after power-on reset or data to be sent has been sent to the shift register. Setting USART_CTRL1.TXDEIEN will generate an interrupt.<br>This bit is cleared to 0 when the software writes the data to be sent into USART_DAT.<br>0: Send data buffer is not empty.<br>1: The transmitting data buffer is empty. |
| 6         | TXC      | Transmission complete.<br>This bit is set to 1 after power-on reset. If USART_STS.TXDE is set, this bit is set when   |

| Bit field | Name  | Description   |
|-----------|-------|---|
|           |       | <p>the current data transmission is completed.</p> <p>Setting USART_CTRL1.TXCIEN bit will generate an interrupt.</p> <p>This bit is cleared by software.</p> <p>0: Transmitting did not complete.</p> <p>1: Send completed.</p>   |
| 5         | RXDNE | <p>The Read data register not empty.</p> <p>This bit is set when the read data buffer receives data from the shift register. When USART_CTRL1.RXDNEIEN bit is set, an interrupt will be generated.</p> <p>Software can clear this bit by writing 0 to it or reading the USART_DAT register.</p> <p>0: The read data buffer is empty.</p> <p>1: The read data buffer is not empty.</p>   |
| 4         | IDLEF | <p>IDLE line detected flag.</p> <p>Within one frame time, the idle state is detected at the RX pin, and this bit is set to 1. When USART_CTRL1.IDLEIEN bit is set, an interrupt will be generated.</p> <p>The software can clear this bit by reading USART_STS first and then reading USART_DAT.</p> <p>0: No idle frame detected.</p> <p>1: idle frame detected.</p> <p><i>Note: IDLEF bit will not be set high again until USART_STS.RXDNE bit is set (that is, an idle line is detected again).</i></p>  |
| 3         | OREF  | <p>Overrun error</p> <p>Overrun error set see 23.4.3.7 chapter.</p> <p>The software can clear this bit by reading USART_STS first and then reading USART_DAT.</p> <p>0: No overrun error was detected.</p> <p>1: Overflow error detected.</p> <p><i>Note: After OREF is set, USART_DAT will not update data again; If RXDNE is 0 at this time, it will not reset to 1 because the data is no longer updated.</i></p>  |
| 2         | NEF   | <p>Noise error flag.</p> <p>When noise is detected in the received frame, this bit is set by hardware. It is cleared by the software sequence (read first USART_STS, read USART_DAT again).</p> <p>0: No noise error detected.</p> <p>1: Noise error detected.</p> <p><i>Note: this bit will not generate an interrupt because it appears with USART_STS.RXDNE, and the hardware will generate an interrupt when setting the USART_STS.RXDNE flag. In the multi-buffer communication mode, if the USART_CTRL3.ERRIEN bit is set, an interrupt will be generated when the NEF flag is set.</i></p> |
| 1         | FEF   | <p>Framing error.</p> <p>When the data is not synchronized or a large amount of noise is detected, and the stop bit is not received and recognized at the expected time, it will be judged that a framing error has been detected, and this bit will be set to 1. First read USART_STS, then read USART_DAT can cleared this bit.</p>   |

| Bit field | Name | Description   |
|-----------|------|---|
|           |      | 0: No framing errors were detected.<br>1: A framing error or a Break Character is detected.<br><i>Note: this bit will not generate an interrupt because it appears with USART_STS.RXDNE, and the hardware will generate an interrupt when setting the USART_STS.RXDNE flag. If the currently transmitted data has both framing errors and overload errors, the hardware will continue to transmit the data and only set the USART_STS.OREF flag bit.</i><br><i>In the multi-buffer communication mode, if the USART_CTRL3.ERRIEN bit is set, an interrupt will be generated when the FEF flag is set.</i> |
| 0         | PEF  | Parity error.<br>This bit is set when the parity bit of the received data frame is different from the expected check value.<br>The software can clear this bit by reading USART_STS first and then reading USART_DAT.<br>0: No parity error was detected.<br>1: Parity error detected.  |

### 23.7.3 USART Data register (USART\_DAT)

Address offset : 0x04

Reset value : undefined (uncertain value)

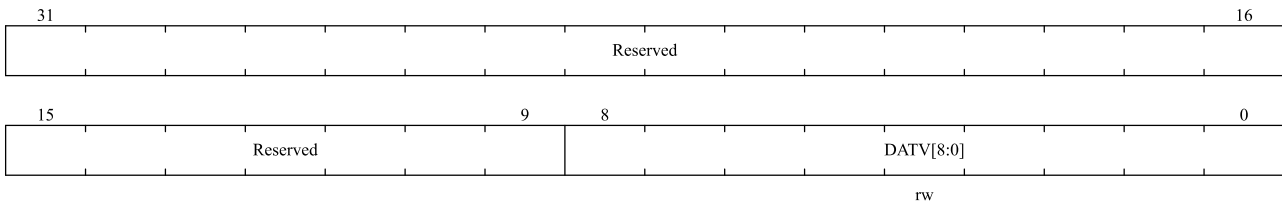

| Bit field | Name      | Description   |
|-----------|-----------|---|
| 31:9      | Reserved  | Reserved, the reset value must be maintained  |
| 8:0       | DATV[8:0] | Data value<br>Contains the data sent or received; Software can change the transmitted data by writing these bits, or read the values of these bits to obtain the received data.<br>If parity is enabled, when the transmitted data is written into the register, the highest bit of the data (the 7th or 8th bit depends on USART_CTRL1.WL bit) will be replaced by the parity bit. |

### 23.7.4 USART Baud rate register (USART\_BRCF)

Address offset : 0x08

Reset value : 0x0000 0000

*Note: When USART\_CTRL1.UEN=1, this register cannot be written; The baud counter stops counting if USART\_CTRL1.TXEN or USART\_CTRL1.RXEN are disabled respectively.*

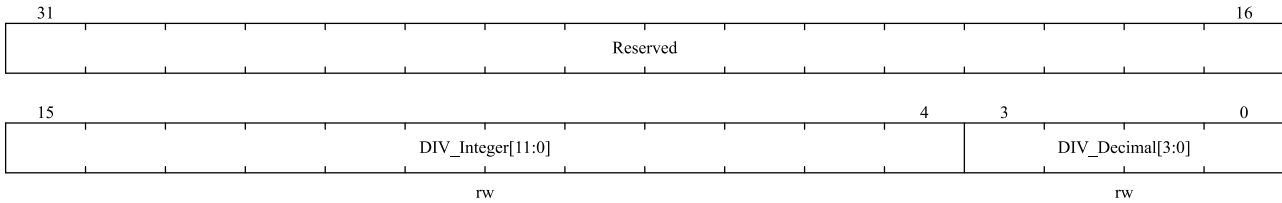

| Bit field | Name              | Description                                  |
|-----------|-------------------|--|
| 31:16     | Reserved          | Reserved, the reset value must be maintained |
| 15:4      | DIV_Integer[11:0] | Integer part of baud rate divider.           |
| 3:0       | DIV_Decimal[3:0]  | Fractional part of baud rate divider.        |

### 23.7.5 USART control register 1 register (USART\_CTRL1)

Address offset : 0x0C

Reset value : 0x0000 0000

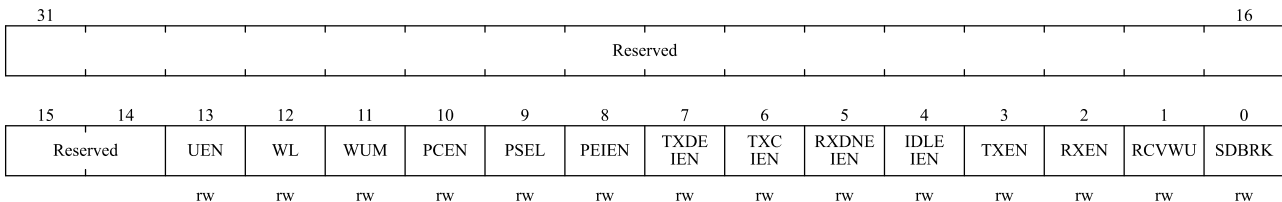

| Bit field | Name     | Description   |
|-----------|----------|---|
| 31:14     | Reserved | Reserved, the reset value must be maintained  |
| 13        | UEN      | USART enable<br>When this bit is cleared, the divider and output of USART stop working after the current byte transmission is completed to reduce power consumption. Software can set or clear this bit.<br>0:USART is disabled.<br>1:USART is enabled. |
| 12        | WL       | Word length.<br>0:8 data bits.<br>1:9 data bits.<br><i>Note: If data is in transit, this bit cannot be configured.</i>  |
| 11        | WUM      | Wake up mode from mute mode.<br>0: Idle frame wake up.<br>1: Address identifier wake up.  |
| 10        | PCEN     | Parity control enable<br>0: Parity control is disabled.<br>1: Parity control is enabled.  |
| 9         | PSEL     | Parity selection.<br>0: even check.<br>1: odd check.  |

| Bit field | Name     | Description  |
|-----------|----------|--|
| 8         | PEIEN    | PE interrupt enable<br>If this bit is set to 1, an interrupt is generated when USART_STS.PEF bit is set.<br>0: Parity error interrupt is disabled.<br>1: Parity error interrupt is enabled.  |
| 7         | TXDEIEN  | TXDE interrupt enable<br>If this bit is set to 1, an interrupt is generated when USART_STS.TXDE bit is set.<br>0: Send buffer empty interrupt is disabled.<br>1: Send buffer empty interrupt is enabled.   |
| 6         | TXCIEN   | Transmit complete interrupt enable.<br>If this bit is set to 1, an interrupt is generated when USART_STS.TXC is set.<br>0: Transmission completion interrupt is disabled.<br>1: Transmission completion interrupt is enabled.  |
| 5         | RXDNEIEN | RXDNE interrupt enable<br>If this bit is set to 1, an interrupt is generated when USART_STS.RXDNE or USART_STS.OREF is set.<br>0: Data buffer non-empty interrupt o and overrun error interrupt are disabled.<br>1: Data buffer non-empty interrupt o and overrun error interrupt are enabled.   |
| 4         | IDLEIEN  | IDLE interrupt enable.<br>If this bit is set to 1, an interrupt is generated when USART_STS.IDLEF is set.<br>0: IDLE line detection interrupt is disabled.<br>1: IDLE line detection interrupt is enabled.   |
| 3         | TXEN     | Transmitter enable.<br>0: The transmitter is disabled.<br>1: the transmitter is enabled.   |
| 2         | RXEN     | Receiver enable<br>0: The receiver is disabled.<br>1: the receiver is enabled.   |
| 1         | RCVWU    | The receiver wakes up<br>Software can set this bit to 1 to make USART enter mute mode, and clear this bit to 0 to wake up USART.<br>In idle frame wake-up mode (USART_CTRL1.WUM=0), this bit is cleared by hardware when an idle frame is detected. In address wake-up mode (USART_CTRL1.WUM=1), when an address matching frame is received, this bit is cleared by hardware. Or when an address mismatch frame is received, it is set to 1 by hardware.<br>0: The receiver is in normal operation mode.<br>1: The receiver is in mute mode. |
| 0         | SDBRK    | Send Break Character.<br>The software transmits a break character by setting this bit to 1.<br>This bit is cleared by hardware during stop bit of the break frame transmission.<br>0: No break character was sent.<br>1: Send a break character.   |

## 23.7.6 USART control register 2 register (USART\_CTRL2)

Address offset : 0x10

Reset value : 0x0000 0000

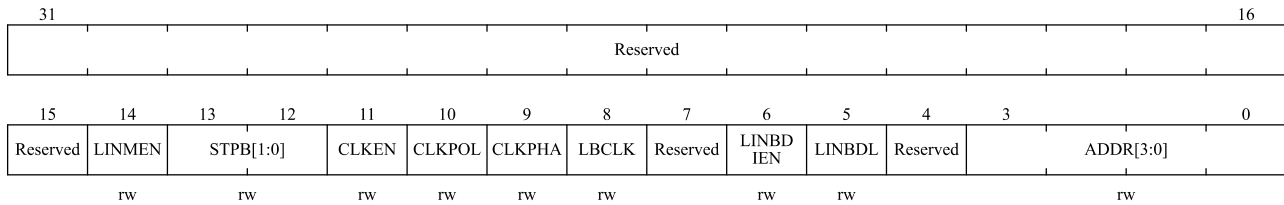

| Bit field | Name      | Description   |
|-----------|-----------|---|
| 31:15     | Reserved  | Reserved, the reset value must be maintained  |
| 14        | LINMEN    | LIN mode enable<br>0:LIN mode is disabled<br>1:LIN mode enabled   |
| 13:12     | STPB[1:0] | STOP bits.<br>00:1 stop bit.<br>01:0.5 stop bit.<br>10:2 stop bit.<br>11:1.5 stop bit.<br><i>Note: For UART4/5/6/7, only one stop bit and two stop bits are valid.</i>  |
| 11        | CLKEN     | Clock enable<br>0:CK pin is disabled<br>1:CK pin enabled<br><i>Note: This bit cannot be used for UART4/5/6/7.</i>   |
| 10        | CLKPOL    | Clock polarity.<br>This bit is used to set the polarity of CK pin in synchronous mode.<br>0: CK pin remains low when it is not transmitted to the outside.<br>1: CK pin remains high when it is not sent to the outside.<br><i>Note: This bit is invalid for UART4/5/6/7.</i>   |
| 9         | CLKPHA    | Clock phase.<br>This bit is used to set the phase of CK pin in synchronous mode.<br>0: Sample the first data at the first clock edge.<br>1: Sample the first data at the second clock edge.<br><i>Note: This bit cannot be used for UART4/5/6/7.</i>  |
| 8         | LBCLK     | The Last bit clock pulse.<br>This bit is used to set whether the clock pulse corresponding to the last transmitted data byte (MSB) is output on CK pin in synchronous mode.<br>0: The clock pulse of the last bit of data is not output from CK.<br>1: The clock pulse of the last bit of data will be output from CK.<br><i>Note: This bit cannot be used for UART4/5/6/7.</i> |
| 7         | Reserved  | Reserved, the reset value must be maintained  |

| Bit field | Name      | Description  |
|-----------|-----------|--|
| 6         | LINBDIEN  | LIN break detection interrupt enable.<br>If this bit is set to 1, an interrupt will be generated when USART_STS.LINBDF bit is set.<br>0: Disconnect signal detection interrupt is disabled.<br>1: Turn-off signal detection interrupt enabled  |
| 5         | LINBDL    | LIN break detection length.<br>This bit is used to set the length of the break frame.<br>0:10 bit break detection<br>1:11 bit break detection<br><i>Note: LINBDL can be used to control the detection length of Break Characters in LIN mode and other modes, and the detection length is the same as that in LIN mode.</i>  |
| 4         | Reserved  | Reserved, the reset value must be maintained   |
| 3:0       | ADDR[3:0] | USART address.<br>Used in the mute mode of multiprocessor communication, using address identification to wake up a USART device.<br>In address wake-up mode (USART_CTRL1.WUM=1), if the lower four bits of the received data frame are not equal to the ADDR[3:0] value, USART will enter the mute mode; If the lower four bits of the received data frame are equal to the ADDR[3:0] value, USART will be awakened. |

### 23.7.7 USART control register 3 register (USART\_CTRL3)

Address offset : 0x14

Reset value : 0x0000 0000

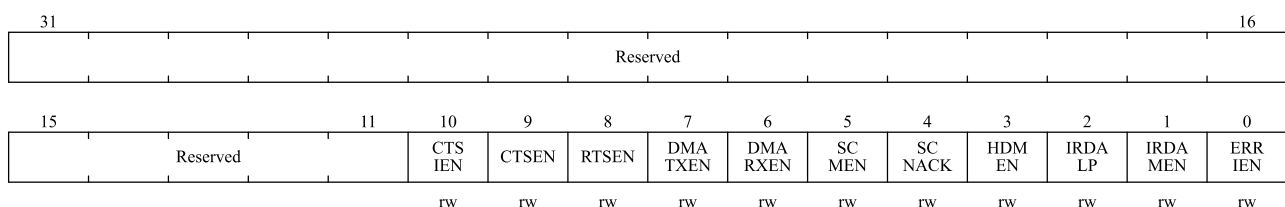

| Bit field | Name     | Description   |
|-----------|----------|---|
| 31:11     | Reserved | Reserved, the reset value must be maintained  |
| 10        | CTSIEN   | CTS interrupt enable.<br>If this bit is set to 1, an interrupt will be generated when USART_STS.CTSF bit is set.<br>0:CTS interrupt is disabled.<br>1:CTS interrupt is enabled.<br><i>Note: This bit cannot be used for UART4/5/6/7</i> |
| 9         | CTSEN    | CTS enable.<br>This bit is used to enable the CTS hardware flow control function.<br>0:CTS hardware flow control is disabled.<br>1:CTS hardware flow control is enabled.<br><i>Note: This bit cannot be used for UART4/5/6/7</i>        |

| Bit field | Name    | Description  |
|-----------|---------|--|
| 8         | RTSEN   | RTS enable.<br>This bit is used to enable RTS hardware flow control function.<br>0:RTS hardware flow control is disabled.<br>1:RTS hardware flow control is enabled.<br><i>Note: This bit cannot be used for UART4/5/6/7</i>   |
| 7         | DMATXEN | DMA transmitter enable.<br>0:DMA transmission mode is disabled.<br>1:DMA transmission mode is enabled.   |
| 6         | DMARXEN | DMA receiver enable.<br>0:DMA receive mode is disabled.<br>1:DMA receive mode is enabled.  |
| 5         | SCMEN   | Smartcard mode enable.<br>This bit is used to enable Smartcard mode.<br>0: Smartcard mode is disabled.<br>1: Smartcard mode is enabled.<br><i>Note: This bit cannot be used for UART4/5/6/7</i>  |
| 4         | SCNACK  | Smartcard NACK enable.<br>This bit is used for Smartcard mode to enable transmitting NACK when parity error occurs.<br>0: Do not send NACK when there is a parity error.<br>1: send NACK when there is a parity error.<br><i>Note: This bit cannot be used for UART4/5/6/7</i> |
| 3         | HDMEN   | Half-duplex mode enable.<br>This bit is used to enable half-duplex mode.<br>0: Half-duplex mode is disabled.<br>1: Half-duplex mode is enabled.  |
| 2         | IRDALP  | IrDA low-power mode.<br>This bit is used to select the low power consumption mode for IrDA mode.<br>0: Normal mode.<br>1: Low power mode.  |
| 1         | IRDAMEN | IrDA mode enable.<br>0:IrDA is disabled.<br>1:IrDA is enabled.   |
| 0         | ERRIEN  | Error interrupt enable.<br>When DMA receive mode (USART_CTRL3.DMARXEN=1) is enabled, an interrupt will be generated when USART_STS.FEF, USART_STS.OREF or USART_STS.NEF bit is set.<br>0: Error interrupt is disabled.<br>1: Error interrupt enabled.                          |

### 23.7.8 USART guard time and prescaler register (USART\_GTP)

Address offset : 0x18

Reset value : 0x0000 0000

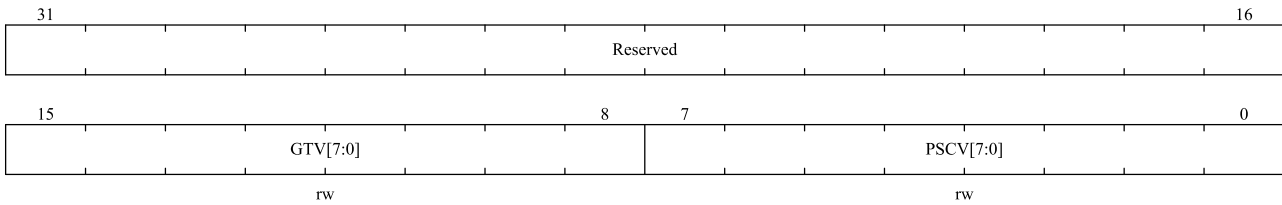

| Bit field | Name      | Description   |
|-----------|-----------|---|
| 31:16     | Reserved  | Reserved, the reset value must be maintained  |
| 15:8      | GTV[7:0]  | <p>Guard time value in Smartcard mode.</p> <p>This bit field specifies the guard time in baud clock. In Smartcard mode, this function is required. The setting time of USART_STS.TXC flag is delayed by GTV[7:0] baud clock cycles.</p> <p><i>Note: This bit is invalid for UART4/5/6/7.</i></p>  |
| 7:0       | PSCV[7:0] | <p>Prescaler value.</p> <p>In IrDA low power consumption mode:<br/>these bits are used to set the frequency division coefficient for dividing the peripheral clock (PCLK1/PCLK2) to generate low power consumption frequency.<br/>00000000: reserved-do not write this value.<br/>00000001: divide the source clock by 1.<br/>...<br/>11111111: divide the source clock by 255.</p> <p>In IrDA normal mode:<br/>PSCV can only be set to 00000001.</p> <p>In Smartcard mode:<br/>PSCV[7:5] is reserved, PSCV[4:0] is used to set the frequency division factor of the peripheral clock (APB1/APB2) to generate the smart card clock. The actual frequency division factor is twice the set value of PSCV[4:0].<br/>0000: reserved - do not write this value.<br/>0001: Divide the source clock by 2.<br/>0010: Divide the source clock by 4.<br/>...<br/>1111: Divide the source clock by 62.</p> <p><i>Note: This bit is invalid for UART4/5/6/7.</i></p> |

## 24 Quad Serial Peripheral Interface (QSPI)

### 24.1 Introduction

QSPI is an interface for single, dual or quad SPI peripheral communication. It can work in indirect or memory mapped modes.

Indirect Mode: All operations are performed using QSPI registers.

Memory Mapped Mode: The external flash memory is mapped into the microcontroller address space, and the system treats it as internal storage space.

### 24.2 QSPI Main features

The main features of the QSPI controller are as follows:

- Support Single SPI/Dual SPI/Quad SPI mode. In Single mode, it supports standard SPI operation and can work in half-duplex and full-duplex modes;
- Support indirect mode and memory mapped mode;
- 8-bit, 16-bit, 32-bit data access mode support;
- Support Individual RX FIFO and TX FIFO that are depth is 32 and width is 32bit;
- Support DMA operation;
- Support FIFO interrupt, operation completion interrupt, data access error interrupt;
- Maximum speed  $4 \times 36\text{Mbps}$ ;
- In indirect mode or memory-mapped mode, operations are divided into Instruction phase, Address phase, Mode bits phase, wait cycles phase, and Data phase. These phase can be configured to be skipped, but at least one phase remains.

*Note: The Mode bits phase is only used in XIP mode.*

*Note: In XIP mode, only read operations are supported to external memory, and write operations are not supported.*

*Note: Only big endian mode is supported when reading external memory data in XIP mode.*

## 24.3 Function description

Figure 24-1 QSPI block diagram

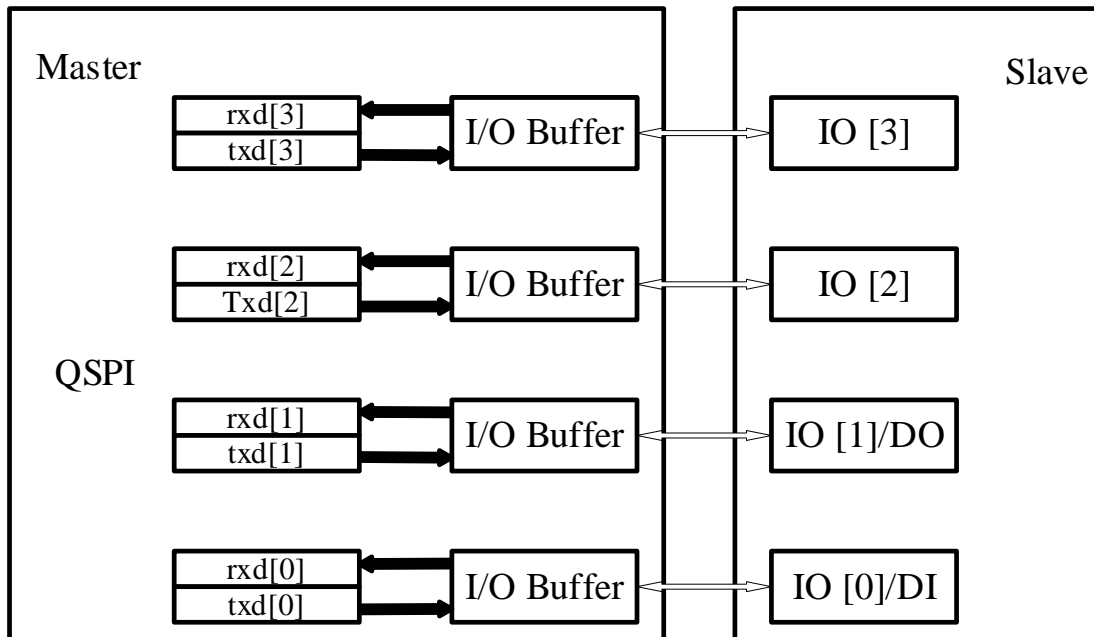

## 24.4 QSPI command sequence

QSPI communicates with peripherals through commands. Each command includes five phase: Instruction phase, Address phase, Mode bits phase, Wait cycles phase and Data phase. Any phase can be skipped, but at least remains one of Instruction phase, Address phase, Mode bits phase or the Data phase.

*Note: The Mode bits phase is only used in XIP mode.*

Figure 24-2 QSPI command sequence

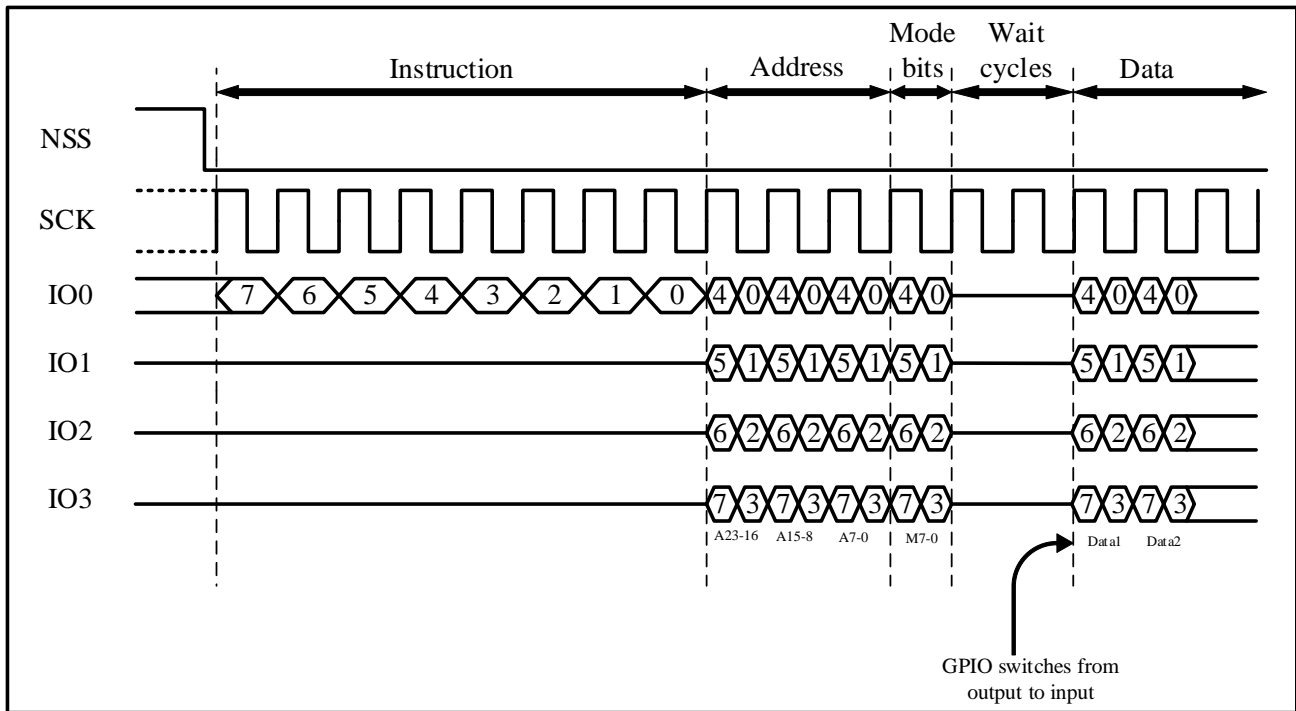

## 24.5 Operating procedures

### 24.5.1 QSPI indirect mode

In indirect mode, instructions are initiated by writing to the QSPI registers, and data is transferred by reading and writing to the data registers, in the same manner as other communication peripherals.

When  $QSPI\_CTRL0.TMOD[1:0] = 00$ , it is working in Tx and Rx mode, both transmit and receive data is valid. Transmission of data continues until the transmit FIFO is empty. The data received from the external device is stored in the receive FIFO memory and can be accessed by the host processor.

*Note: Tx and Rx modes are only available in Single SPI mode ( $QSPI\_CTRL0.SPI\_FRF[1:0] = 00$ )*

When  $QSPI\_CTRL0.TMOD[1:0] = 01$ , the QSPI is in indirect transmission mode, and the byte to be transmitted is sent to the flash memory during the data transmission phase, and the data is provided by writing the  $QSPI\_DATx$  register.

When  $QSPI\_CTRL0.TMOD[1:0] = 10$ , the QSPI is in indirect receive mode, the data to be received is received from the flash memory in the data receive phase, and the data is obtained by reading the  $QSPI\_DATx$  register.

When  $QSPI\_CTRL0.TMOD[1:0] = 11$ , EEPROM read mode, transmit data is used to send opcode or address to EEPROM device.

*Note: EEPROM read mode is only available in Single SPI mode ( $QSPI\_CTRL0.SPI\_FRF[1:0] = 00$ )*

The number of bytes to read is specified in  $QSPI\_CTRL1.NDF[15:0]$ .

## 24.5.2 QSPI Indirect send operation

- 1 QSPI\_CTRL0.SPI\_FRF[1:0] specifies the frame transmission format (standard/dual-wire/quad-wire mode)
- 2 QSPI\_CTRL0.DFS[4:0] specifies the data length (4~32bit)
- 3 QSPI\_ENH\_CTRL0.ADDR\_LEN[3:0] specifies the address length (4bit~60bit, configurable to skip the Address phase)
- 4 QSPI\_ENH\_CTRL0.INST\_L[1:0] specifies the instruction length (4bit, 8bit, 16bit, configurable to skip the Instruction stage)

*Note: One instruction occupies one FIFO address, and the address can occupy multiple FIFO locations. Both instructions and addresses must be programmed in the QSPI\_DATx registers.*

The write operation can be divided into three phase: the Instruction phase, the Address phase, and the Data phase.

### ■ Typical Write Timing

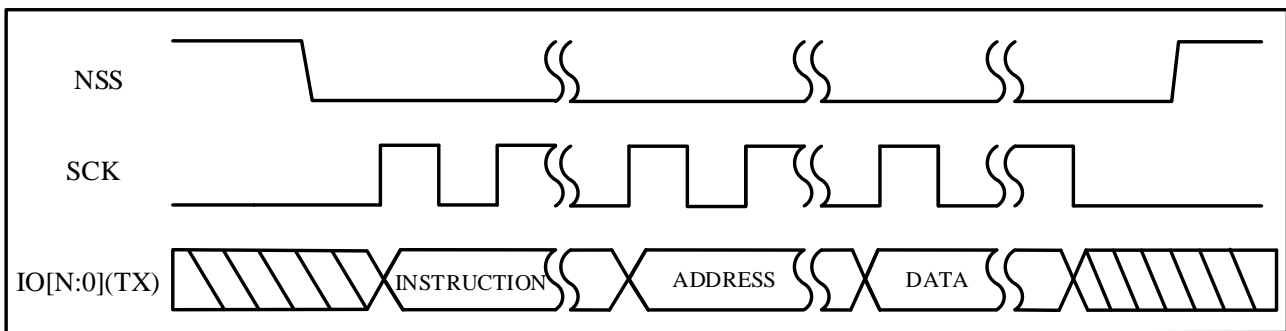

In Quad mode N=3, for 1 write operation, the instruction and address are sent only once, then the data frame stored in QSPI\_DATx registers, until the send FIFO is empty.

### ■ When both instruction and address are sent in standard SPI format

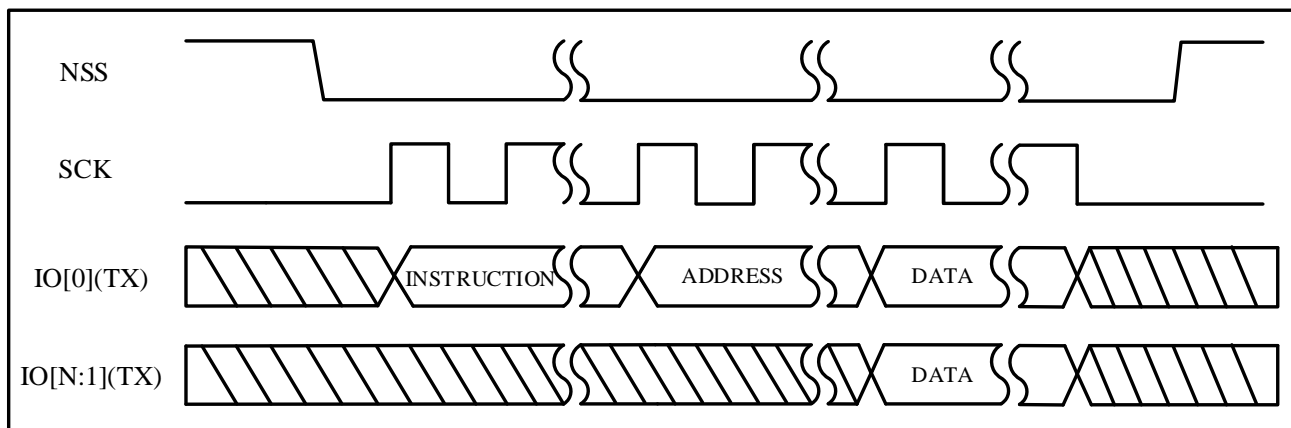

QSPI\_ENH\_CTRL0.TRANS\_TYPE[1:0] shall be configured as 0. When QSPI\_CTRL0.SPI\_FRF[1:0] is configured as 0x02 (Quad mode), N=3; when QSPI\_CTRL0.SPI\_FRF[1:0] is configured as 0x01 (Dual mode), N=1.

- The instruction is sent in standard SPI mode, and the address is sent in the CTRL0.SPI\_FRF mode.

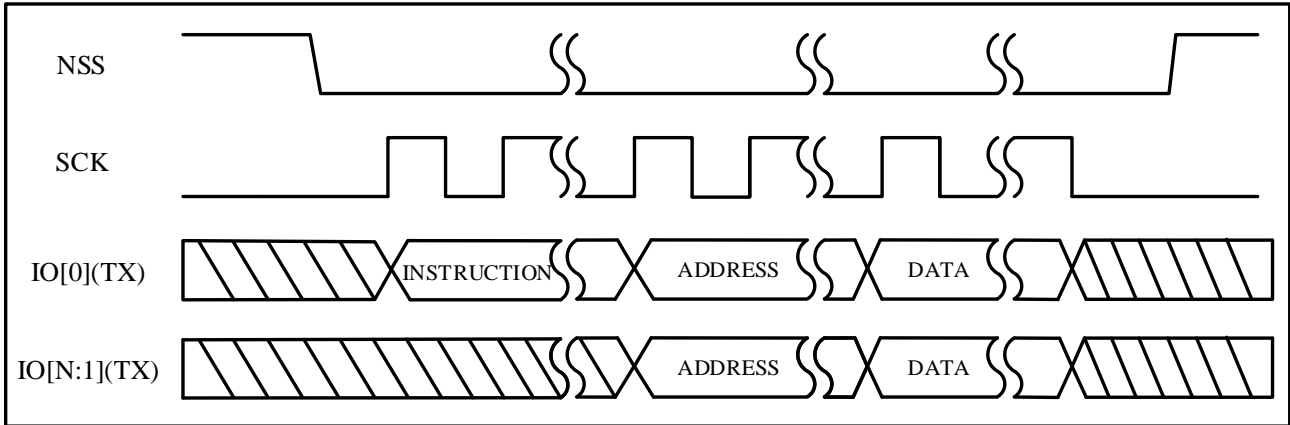

QSPI\_ENH\_CTRL0.TRANS\_TYPE[1:0] shall be configured as 0x01. When QSPI\_CTRL0.SPI\_FRF[1:0] is configured as 0x02 (Quad mode), N=3; when QSPI\_CTRL0.SPI\_FRF[1:0] is configured as 0x01 (Dual mode), N=1.

- Instruction and address are sent timing in CTRL0.SPI\_FRF specified mode

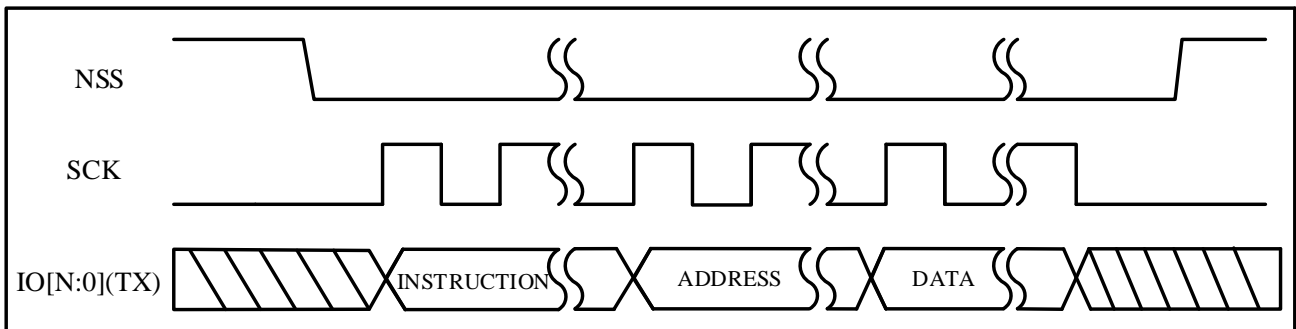

QSPI\_ENH\_CTRL0.TRANS\_TYPE[1:0] shall be configured as 0x02. When QSPI\_CTRL0.SPI\_FRF[1:0] is configured as 0x02 (Quad mode), N=3; when QSPI\_CTRL0.SPI\_FRF[1:0] is configured as 0x01 (Dual mode), N=1.

- Only the send timing of the Instruction phase

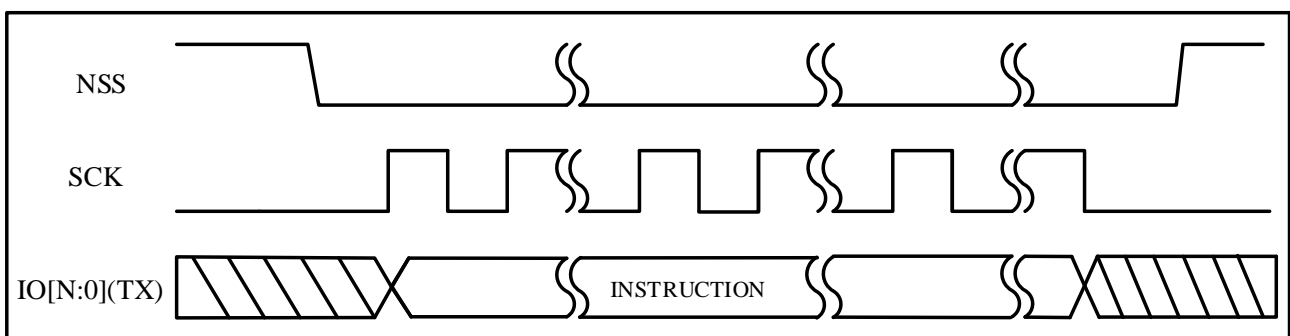

Regardless of the QSPI\_ENH\_CTRL0.TRANS\_TYPE[1:0] configuration. When QSPI\_CTRL0.SPI\_FRF[1:0] is configured as 0x02 (Quad mode), N=3; when QSPI\_CTRL0.SPI\_FRF[1:0] is configured as 0x01 (Dual mode), N=1.

### 24.5.3 QSPI indirect receive operation

For a read operation, QSPI sends the command and control data once until it receives data equal to the number of

NDF (QSPI\_CTRL1[15:0]), and then cancels the slave select signal. The read operation can be divided into 4 phase: Instruction phase, Address phase, Wait cycles phase and Data phase.

■ Typical Read Operation Timing

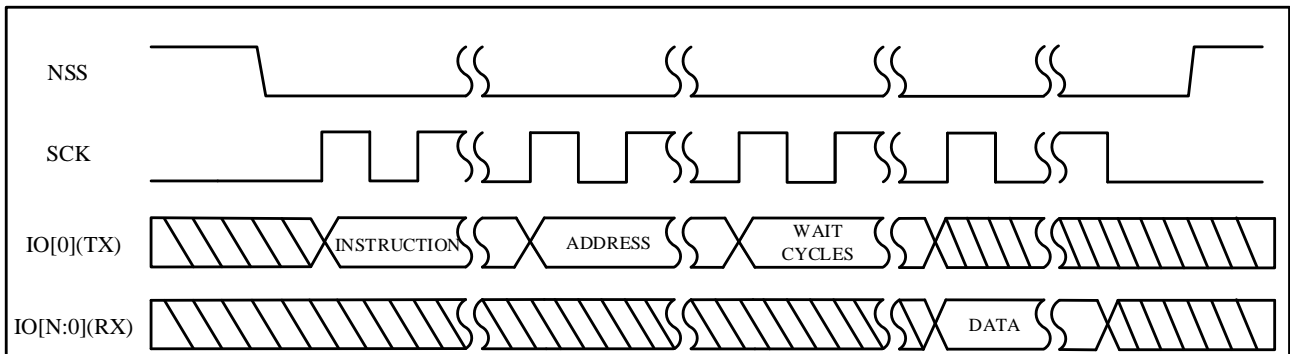

In quad mode  $N=3$ , each read command data will be transmitted in the format configured by QSPI\_CTRL0.SPI\_FRF[1:0]. Configured as 0x2 for quad mode.

■ Both address and instruction receive timing in standard SPI format

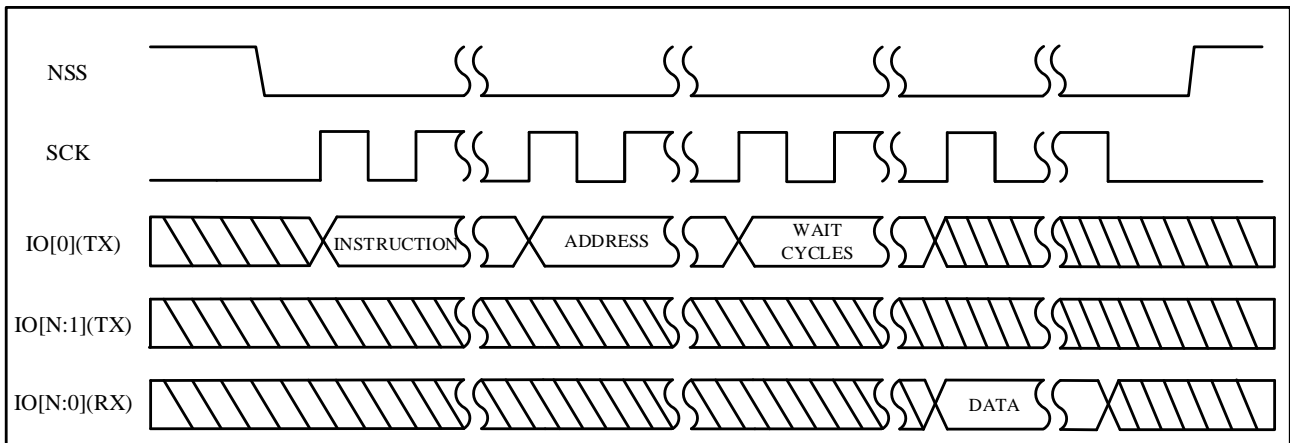

QSPI\_ENH\_CTRL0.TRANS\_TYPE[1:0] should be configured as 0x0, QSPI\_ENH\_CTRL0.WAIT\_CYCLES[4:0] configure the cycle of WAIT. When QSPI\_CTRL0.SPI\_FRF[1:0] is configured as 0x02 (Quad mode),  $N=3$ ; when QSPI\_CTRL0.SPI\_FRF[1:0] is configured as 0x01 (Dual mode),  $N=1$ .

■ The instruction is sent in standard SPI mode, and the address is received in the mode specified by QSPI\_CTRL0.SPI\_FRF.

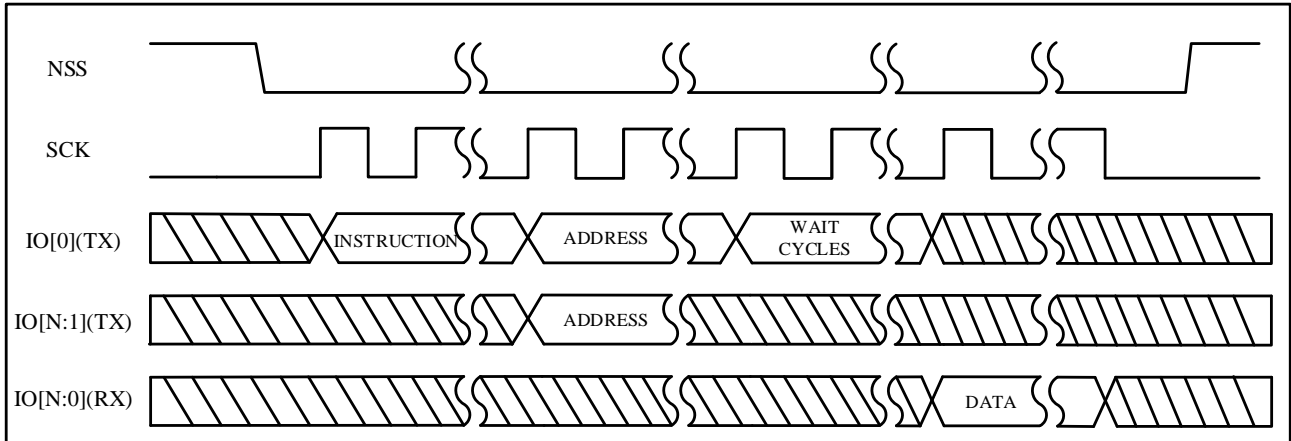

QSPI\_ENH\_CTRL0.TRANS\_TYPE[1:0] should be configured as 0x1, QSPI\_ENH\_CTRL0.WAIT\_CYCLES[4:0] configure the cycle of WAIT. When QSPI\_CTRL0.SPI\_FRF[1:0] is configured as 0x02 (Quad mode), N=3; when QSPI\_CTRL0.SPI\_FRF[1:0] is configured as 0x01 (Dual mode), N=1.

- Instruction and address are received timing in QSPI\_CTRL0.SPI\_FRF specified mode

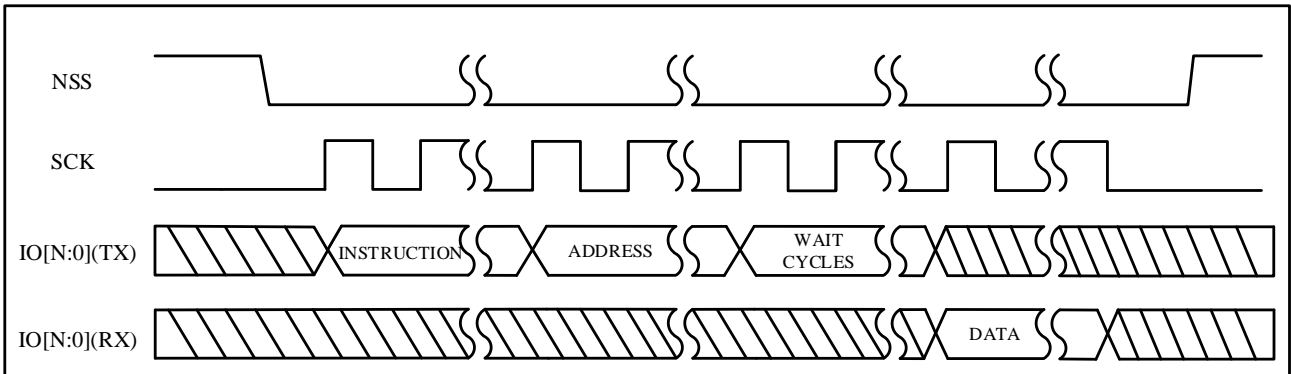

The QSPI\_ENH\_CTRL0.TRANS\_TYPE[1:0] configuration should be 0x2. When QSPI\_CTRL0.SPI\_FRF[1:0] is configured as 0x02 (Quad mode), N=3; when QSPI\_CTRL0.SPI\_FRF[1:0] is configured as 0x01 (Dual mode), N=1.

- Only the receive timing of the Wait cycles phase

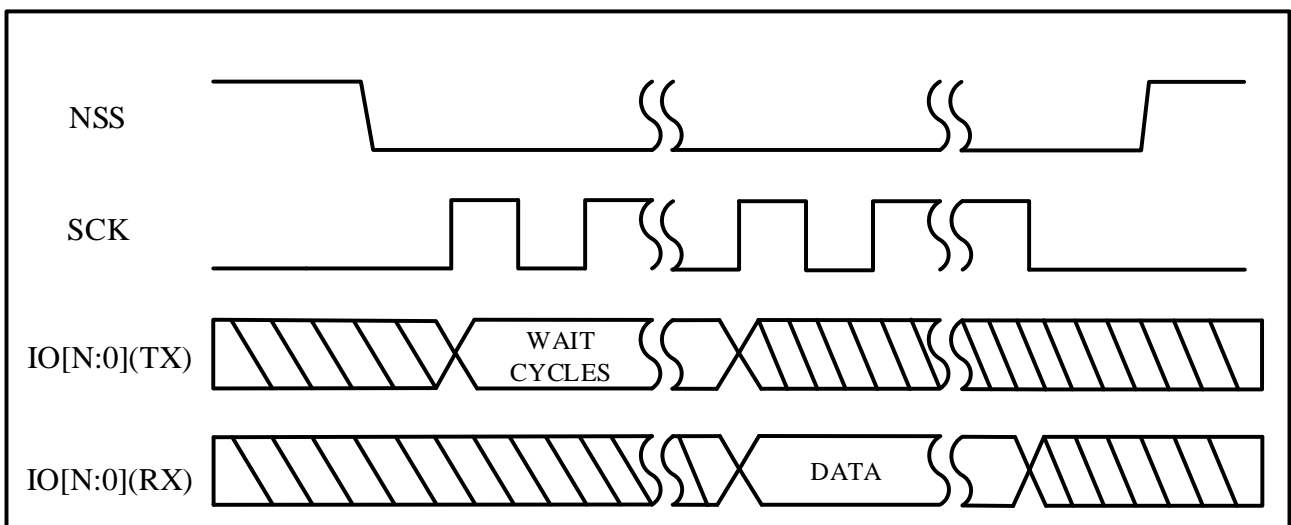

QSPI\_ENH\_CTRL0.ADDR\_LEN[3:0] is configured to 0, QSPI\_ENH\_CTRL0.INST\_L[1:0] is configured to 0, and

QSPI\_ENH\_CTRL0.WAIT\_CYCLES[4:0] is configured to wait cycles. When QSPI\_CTRL0.SPI\_FRF[1:0] is configured as 0x02 (Quad mode), N=3; when QSPI\_CTRL0.SPI\_FRF[1:0] is configured as 0x01 (Dual mode), N=1.

## 24.6 QSPI register

### 24.6.1 QSPI register overview

Table 24-1 QSPI register overview

| Offset | Register      | 31       | 30 | 29 | 28 | 27 | 26 | 25 | 24 | 23 | 22 | 21           | 20 | 19       | 18 | 17       | 16            | 15       | 14 | 13 | 12 | 11       | 10 | 9    | 8   | 7             | 6 | 5         | 4 | 3             | 2      | 1        | 0   |          |   |          |   |   |   |   |   |   |   |   |   |   |
|--------|---------------|----------|----|----|----|----|----|----|----|----|----|--------------|----|----------|----|----------|---------------|----------|----|----|----|----------|----|------|-----|---------------|---|-----------|---|---------------|--------|----------|-----|----------|---|----------|---|---|---|---|---|---|---|---|---|---|
| 000h   | QSPI_CTRL0    | Reserved |    |    |    |    |    |    |    |    |    | SPI_FRF[1:0] |    | Reserved |    |          |               | CFS[3:0] |    |    |    | Reserved |    | SSTE | SRL | Reserved      |   | TMOD[1:0] |   | SCPOL         | SCPH   | FRF[1:0] |     | Reserved |   | DFS[4:0] |   |   |   |   |   |   |   |   |   |   |
|        | Reset Value   |          |    |    |    |    |    |    |    |    |    | 1            | 0  |          |    |          |               | 0        | 0  | 0  | 0  |          | 1  | 0    |     |               | 0 | 1         | 0 | 0             | 0      | 0        |     |          | 0 | 0        | 1 | 1 | 1 |   |   |   |   |   |   |   |
| 004h   | QSPI_CTRL1    | Reserved |    |    |    |    |    |    |    |    |    |              |    |          |    |          | NDF[15:0]     |          |    |    |    |          |    |      |     |               |   |           |   |               |        |          |     |          |   |          |   |   |   |   |   |   |   |   |   |   |
|        | Reset Value   |          |    |    |    |    |    |    |    |    |    |              |    |          |    |          | 0             | 0        | 0  | 0  | 0  | 0        | 0  | 0    | 0   | 0             | 0 | 0         | 0 | 0             | 0      | 0        | 0   | 0        | 0 | 0        | 0 | 0 | 0 | 0 | 0 | 0 | 0 | 0 | 0 | 0 |
| 008h   | QSPI_EN       | Reserved |    |    |    |    |    |    |    |    |    |              |    |          |    |          |               |          |    |    |    |          |    |      |     |               |   |           |   |               |        |          | QEN |          |   |          |   |   |   |   |   |   |   |   |   |   |
|        | Reset Value   |          |    |    |    |    |    |    |    |    |    |              |    |          |    |          |               |          |    |    |    |          |    |      |     |               |   |           |   |               |        |          | 0   |          |   |          |   |   |   |   |   |   |   |   |   |   |
| 00Ch   | QSPI_MW_CTRL  | Reserved |    |    |    |    |    |    |    |    |    |              |    |          |    |          |               |          |    |    |    |          |    |      |     |               |   |           |   | MHS_EN        | MC_DIR | MW/MOD   |     |          |   |          |   |   |   |   |   |   |   |   |   |   |
|        | Reset Value   |          |    |    |    |    |    |    |    |    |    |              |    |          |    |          |               |          |    |    |    |          |    |      |     |               |   |           |   | 0             | 0      | 0        |     |          |   |          |   |   |   |   |   |   |   |   |   |   |
| 010h   | QSPI_SLAVE_EN | Reserved |    |    |    |    |    |    |    |    |    |              |    |          |    |          |               |          |    |    |    |          |    |      |     |               |   |           |   |               |        |          | SEN |          |   |          |   |   |   |   |   |   |   |   |   |   |
|        | Reset Value   |          |    |    |    |    |    |    |    |    |    |              |    |          |    |          |               |          |    |    |    |          |    |      |     |               |   |           |   |               |        |          | 0   |          |   |          |   |   |   |   |   |   |   |   |   |   |
| 014h   | QSPI_BAUD     | Reserved |    |    |    |    |    |    |    |    |    |              |    |          |    |          | CLK_DIV[15:0] |          |    |    |    |          |    |      |     |               |   |           |   |               |        |          |     |          |   |          |   |   |   |   |   |   |   |   |   |   |
|        | Reset Value   |          |    |    |    |    |    |    |    |    |    |              |    |          |    |          | 0             | 0        | 0  | 0  | 0  | 0        | 0  | 0    | 0   | 0             | 0 | 0         | 0 | 0             | 0      | 0        | 0   | 0        | 0 | 0        | 0 | 0 | 0 | 0 | 0 | 0 | 0 | 0 | 0 |   |
| 018h   | QSPI_TXFT     | Reserved |    |    |    |    |    |    |    |    |    | TXFT_ST[4:0] |    |          |    | Reserved |               |          |    |    |    |          |    |      |     | TXFT_TEI[4:0] |   |           |   |               |        |          |     |          |   |          |   |   |   |   |   |   |   |   |   |   |
|        | Reset Value   |          |    |    |    |    |    |    |    |    |    | 0            | 0  | 0        | 0  | 0        |               |          |    |    |    |          |    |      |     |               | 0 | 0         | 0 | 0             | 0      |          |     |          |   |          |   |   |   |   |   |   |   |   |   |   |
| 01Ch   | QSPI_RXFT     | Reserved |    |    |    |    |    |    |    |    |    |              |    |          |    |          |               |          |    |    |    |          |    |      |     |               |   |           |   | RXFT_TFI[4:0] |        |          |     |          |   |          |   |   |   |   |   |   |   |   |   |   |
|        | Reset Value   |          |    |    |    |    |    |    |    |    |    |              |    |          |    |          |               |          |    |    |    |          |    |      |     |               |   |           |   | 0             | 0      | 0        | 0   | 0        |   |          |   |   |   |   |   |   |   |   |   |   |
| 020h   | QSPI_TXFN     | Reserved |    |    |    |    |    |    |    |    |    |              |    |          |    |          |               |          |    |    |    |          |    |      |     | TXFN[5:0]     |   |           |   |               |        |          |     |          |   |          |   |   |   |   |   |   |   |   |   |   |
|        | Reset Value   |          |    |    |    |    |    |    |    |    |    |              |    |          |    |          |               |          |    |    |    |          |    |      |     | 0             | 0 | 0         | 0 | 0             | 0      |          |     |          |   |          |   |   |   |   |   |   |   |   |   |   |
| 024h   | QSPI_RXFN     | Reserved |    |    |    |    |    |    |    |    |    |              |    |          |    |          |               |          |    |    |    |          |    |      |     | RXFN[5:0]     |   |           |   |               |        |          |     |          |   |          |   |   |   |   |   |   |   |   |   |   |
|        | Reset Value   |          |    |    |    |    |    |    |    |    |    |              |    |          |    |          |               |          |    |    |    |          |    |      |     | 0             | 0 | 0         | 0 | 0             | 0      |          |     |          |   |          |   |   |   |   |   |   |   |   |   |   |

| Offset              | Register         | 31         | 30       | 29 | 28 | 27 | 26 | 25 | 24 | 23 | 22 | 21 | 20 | 19 | 18 | 17  | 16          | 15         | 14               | 13 | 12 | 11 | 10       | 9            | 8        | 7             | 6        | 5       | 4               | 3       | 2           | 1        | 0     |      |   |
|---------------------|------------------|------------|----------|----|----|----|----|----|----|----|----|----|----|----|----|-----|-------------|------------|------------------|----|----|----|----------|--------------|----------|---------------|----------|---------|-----------------|---------|-------------|----------|-------|------|---|
| 028h                | QSPL_STS         | Reserved   |          |    |    |    |    |    |    |    |    |    |    |    |    |     |             |            |                  |    |    |    |          |              |          | DC_ERR        | Reserved |         |                 | RXFF    | RXFNE       | TXFE     | TXFNF | BUSY |   |
|                     | Reset Value      |            |          |    |    |    |    |    |    |    |    |    |    |    |    |     |             |            |                  |    |    |    |          |              |          | 0             | Reserved |         |                 | 0       | 0           | 1        | 1     | 0    |   |
| 02Ch                | QSPL_IMASK       | Reserved   |          |    |    |    |    |    |    |    |    |    |    |    |    |     |             |            |                  |    |    |    |          |              |          | XRROIM        | MMCM     | RXFFIM  | RXFOIM          | RXFUIM  | TXFOIM      | TXFEIM   |       |      |   |
|                     | Reset Value      |            |          |    |    |    |    |    |    |    |    |    |    |    |    |     |             |            |                  |    |    |    |          |              |          | 1             | 1        | 1       | 1               | 1       | 1           | 1        |       |      |   |
| 030h                | QSPL_ISTS        | Reserved   |          |    |    |    |    |    |    |    |    |    |    |    |    |     |             |            |                  |    |    |    |          |              |          | XRROIS        | MMCS     | RXFFIS  | RXFOIS          | RXFUIS  | TXFOIS      | TXFEIS   |       |      |   |
|                     | Reset Value      |            |          |    |    |    |    |    |    |    |    |    |    |    |    |     |             |            |                  |    |    |    |          |              |          | 0             | 0        | 0       | 0               | 0       | 0           | 0        |       |      |   |
| 034h                | QSPL_RISTS       | Reserved   |          |    |    |    |    |    |    |    |    |    |    |    |    |     |             |            |                  |    |    |    |          |              |          | XRRORI        | MMCRIS   | RXFFRIS | RXFORIS         | RXFURIS | TXFORIS     | TXFERIS  |       |      |   |
|                     | Reset Value      |            |          |    |    |    |    |    |    |    |    |    |    |    |    |     |             |            |                  |    |    |    |          |              |          | 0             | 0        | 0       | 0               | 0       | 0           | 0        |       |      |   |
| 038h                | QSPL_TXFOI_CL    | Reserved   |          |    |    |    |    |    |    |    |    |    |    |    |    |     |             |            |                  |    |    |    |          |              |          |               |          |         |                 |         | TXFOIC      |          |       |      |   |
|                     | Reset Value      |            |          |    |    |    |    |    |    |    |    |    |    |    |    |     |             |            |                  |    |    |    |          |              |          |               |          |         |                 |         | 0           |          |       |      |   |
| 03Ch                | QSPL_RXFOI_CL    | Reserved   |          |    |    |    |    |    |    |    |    |    |    |    |    |     |             |            |                  |    |    |    |          |              |          |               |          |         |                 |         | RXFOIC      |          |       |      |   |
|                     | Reset Value      |            |          |    |    |    |    |    |    |    |    |    |    |    |    |     |             |            |                  |    |    |    |          |              |          |               |          |         |                 |         | 0           |          |       |      |   |
| 040h                | QSPL_RXFUI_CL    | Reserved   |          |    |    |    |    |    |    |    |    |    |    |    |    |     |             |            |                  |    |    |    |          |              |          |               |          |         |                 |         | RXFUIC      |          |       |      |   |
|                     | Reset Value      |            |          |    |    |    |    |    |    |    |    |    |    |    |    |     |             |            |                  |    |    |    |          |              |          |               |          |         |                 |         | 0           |          |       |      |   |
| 044h                | QSPL_MMC_CLR     | Reserved   |          |    |    |    |    |    |    |    |    |    |    |    |    |     |             |            |                  |    |    |    |          |              |          |               |          |         |                 |         | MMCMC       |          |       |      |   |
|                     | Reset Value      |            |          |    |    |    |    |    |    |    |    |    |    |    |    |     |             |            |                  |    |    |    |          |              |          |               |          |         |                 |         | 0           |          |       |      |   |
| 048h                | QSPL_ICLR        | Reserved   |          |    |    |    |    |    |    |    |    |    |    |    |    |     |             |            |                  |    |    |    |          |              |          |               |          |         |                 |         | INTC        |          |       |      |   |
|                     | Reset Value      |            |          |    |    |    |    |    |    |    |    |    |    |    |    |     |             |            |                  |    |    |    |          |              |          |               |          |         |                 |         | 0           |          |       |      |   |
| 04Ch                | QSPL_DMA_CTR     | Reserved   |          |    |    |    |    |    |    |    |    |    |    |    |    |     |             |            |                  |    |    |    |          |              |          |               |          |         |                 |         | TX_DMA_E    | RX_DMA_E |       |      |   |
|                     | Reset Value      |            |          |    |    |    |    |    |    |    |    |    |    |    |    |     |             |            |                  |    |    |    |          |              |          |               |          |         |                 |         | 0           | 0        |       |      |   |
| 050h                | QSPL_DMATDL_CTRL | Reserved   |          |    |    |    |    |    |    |    |    |    |    |    |    |     |             |            |                  |    |    |    |          |              |          |               |          |         |                 |         | DMATDL[5:0] |          |       |      |   |
|                     | Reset Value      |            |          |    |    |    |    |    |    |    |    |    |    |    |    |     |             |            |                  |    |    |    |          |              |          |               |          |         |                 |         | 0           | 0        | 0     | 0    | 0 |
| 054h                | QSPL_DMARDL_CTRL | Reserved   |          |    |    |    |    |    |    |    |    |    |    |    |    |     |             |            |                  |    |    |    |          |              |          |               |          |         |                 |         | DMARDL[5:0] |          |       |      |   |
|                     | Reset Value      |            |          |    |    |    |    |    |    |    |    |    |    |    |    |     |             |            |                  |    |    |    |          |              |          |               |          |         |                 |         | 0           | 0        | 0     | 0    | 0 |
| 060h+004h*x(x=0~31) | QSPL_DATx        | DATx[31:0] |          |    |    |    |    |    |    |    |    |    |    |    |    |     |             |            |                  |    |    |    |          |              |          |               |          |         |                 |         |             |          |       |      |   |
|                     | Reset Value      | 0          | 0        | 0  | 0  | 0  | 0  | 0  | 0  | 0  | 0  | 0  | 0  | 0  | 0  | 0   | 0           | 0          | 0                | 0  | 0  | 0  | 0        | 0            | 0        | 0             | 0        | 0       | 0               | 0       | 0           | 0        |       |      |   |
| 0F0h                | QSPL_RS_DELA_Y   | Reserved   |          |    |    |    |    |    |    |    |    |    |    |    |    | SES | Reserved    |            |                  |    |    |    |          | SDCN[7:0]    |          |               |          |         |                 |         |             |          |       |      |   |
|                     | Reset Value      |            |          |    |    |    |    |    |    |    |    |    |    |    |    | 0   |             |            |                  |    |    |    |          | 0            | 0        | 0             | 0        | 0       | 0               | 0       | 0           | 0        |       |      |   |
| 0F4h                | QSPL_ENH_CTR_LO  | Reserved   | Reserved |    |    |    |    |    |    |    |    |    |    |    |    |     | INST_DDR_EN | SPL_DDR_EN | WAIT_CYCLES[4:0] |    |    |    | Reserved | INST_L1[1:0] | Reserved | ADDR_LEN[3:0] |          |         | TRANS_TYPE[1:0] |         |             |          |       |      |   |
|                     | Reset Value      |            |          |    |    |    |    |    |    |    |    |    |    |    |    |     |             |            |                  |    |    |    |          |              |          |               |          |         |                 |         |             |          |       |      |   |

| Offset | Register               | 31       | 30 | 29           | 28 | 27       | 26 | 25        | 24          | 23       | 22          | 21     | 20     | 19               | 18 | 17 | 16                | 15         | 14       | 13          | 12 | 11       | 10            | 9 | 8 | 7               | 6 | 5        | 4        | 3 | 2 | 1 | 0 |
|--------|------------------------|----------|----|--------------|----|----------|----|-----------|-------------|----------|-------------|--------|--------|------------------|----|----|-------------------|------------|----------|-------------|----|----------|---------------|---|---|-----------------|---|----------|----------|---|---|---|---|
|        | Reset Value            | 0        |    |              |    |          |    |           |             |          |             |        |        |                  |    | 0  | 0                 | 0          | 0        | 0           | 0  | 0        | 0             | 1 | 0 |                 |   | 0        | 0        | 0 | 0 | 0 | 0 |
| 0F8h   | QSPL_DDR_TXD<br>E      | Reserved |    |              |    |          |    |           |             |          |             |        |        |                  |    |    |                   |            |          |             |    |          |               |   |   | TXDE[7:0]       |   |          |          |   |   |   |   |
|        | Reset Value            |          |    |              |    |          |    |           |             |          |             |        |        |                  |    |    |                   |            |          |             |    |          |               |   |   |                 |   | 0        | 0        | 0 | 0 | 0 | 0 |
| 0FCh   | QSPL_XIP_MODE          | Reserved |    |              |    |          |    |           |             |          |             |        |        |                  |    |    | XIP_MD_BITS[15:0] |            |          |             |    |          |               |   |   |                 |   |          |          |   |   |   |   |
|        | Reset Value            |          |    |              |    |          |    |           |             |          |             |        |        |                  |    |    | 0                 | 0          | 0        | 0           | 0  | 0        | 0             | 0 | 0 | 0               | 0 | 0        | 0        | 0 | 0 | 0 |   |
| 100h   | QSPL_XIP_INCR_<br>TOC  | Reserved |    |              |    |          |    |           |             |          |             |        |        |                  |    |    | ITOC[15:0]        |            |          |             |    |          |               |   |   |                 |   |          |          |   |   |   |   |
|        | Reset Value            |          |    |              |    |          |    |           |             |          |             |        |        |                  |    |    | 0                 | 0          | 0        | 0           | 0  | 0        | 0             | 0 | 0 | 0               | 0 | 0        | 0        | 0 | 0 | 0 |   |
| 104h   | QSPL_XIP_WRAP_<br>_TOC | Reserved |    |              |    |          |    |           |             |          |             |        |        |                  |    |    | WTOC[15:0]        |            |          |             |    |          |               |   |   |                 |   |          |          |   |   |   |   |
|        | Reset Value            |          |    |              |    |          |    |           |             |          |             |        |        |                  |    |    | 0                 | 0          | 0        | 0           | 0  | 0        | 0             | 0 | 0 | 0               | 0 | 0        | 0        | 0 | 0 | 0 |   |
| 108h   | QSPL_XIP_CTRL          | Reserved |    | XIP_MBL[1:0] |    | Reserved |    | XIP_CT_EN | XIP_INST_EN | Reserved | INST_DDR_EN | DDR_EN | DFS_HC | WAIT_CYCLES[4:0] |    |    |                   | MD_BITS_EN | Reserved | INST_L[1:0] |    | Reserved | ADDR_LEN[3:0] |   |   | TRANS_TYPE[1:0] |   | FRF[1:0] |          |   |   |   |   |
|        | Reset Value            |          |    |              |    |          |    | 1         | 1           |          | 0           | 0      | 0      | 0                | 0  | 0  | 0                 | 0          | 0        | 0           | 1  | 0        |               |   | 0 | 0               | 0 | 0        | 0        | 0 | 1 | 0 |   |
| 10Ch   | QSPL_XIP_SLAV<br>E_EN  | Reserved |    |              |    |          |    |           |             |          |             |        |        |                  |    |    |                   |            |          |             |    |          |               |   |   |                 |   |          | SEN      |   |   |   |   |
|        | Reset Value            |          |    |              |    |          |    |           |             |          |             |        |        |                  |    |    |                   |            |          |             |    |          |               |   |   |                 |   |          |          |   |   | 0 |   |
| 110h   | QSPL_XIP_RXFO<br>I_CLR | Reserved |    |              |    |          |    |           |             |          |             |        |        |                  |    |    |                   |            |          |             |    |          |               |   |   |                 |   |          | XRFXFOIC |   |   |   |   |
|        | Reset Value            |          |    |              |    |          |    |           |             |          |             |        |        |                  |    |    |                   |            |          |             |    |          |               |   |   |                 |   |          |          |   |   | 0 |   |
| 114h   | QSPL_XIP_TOUT          | Reserved |    |              |    |          |    |           |             |          |             |        |        |                  |    |    |                   |            |          |             |    |          |               |   |   | XTOUT[7:0]      |   |          |          |   |   |   |   |
|        | Reset Value            |          |    |              |    |          |    |           |             |          |             |        |        |                  |    |    |                   |            |          |             |    |          |               |   |   |                 |   |          |          |   |   | 0 |   |

### 24.6.2 QSPI Control 0 Register (QSPI\_CTRL0)

QSPI\_CTRL0 register controls the serial data transfer.

*Note: This register cannot be written when the QSPI\_EN.QEN = 1.*

Address offset: 0x00

Reset value: 0x0080 4407

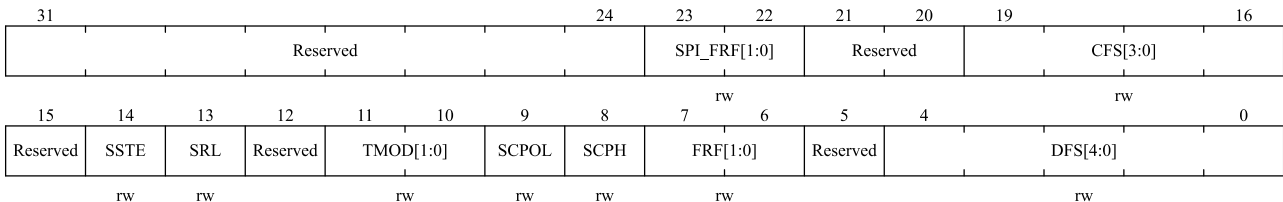

| Bit field | Name         | Description                                  |
|-----------|--------------|--|
| 31:24     | Reserved     | Reserved, the reset value must be maintained |
| 23:22     | SPI_FRF[1:0] | SPI Frame Format<br>00: Standard SPI Format  |

| Bit field | Name      | Description   |
|-----------|-----------|---|
|           |           | 01: Dual SPI Format<br>10: Quad SPI Format<br>11: Reserved  |
| 21:20     | Reserved  | Reserved, the reset value must be maintained  |
| 19:16     | CFS[3:0]  | Control Frame Size<br>Selects the length of the control word for the Microwire frame format.<br>0000: 1bit Control Word<br>0001: 2bit Control Word<br>0010: 3bit Control Word<br>0011: 4bit Control Word<br>.....<br>1110: 15bit Control Word<br>1111: 16bit Control Word   |
| 15        | Reserved  | Reserved, the reset value must be maintained  |
| 14        | SSTE      | Slave Select Toggle Enable<br>While operating in SPI mode with clock phase (SCPH) set to 0, this bit controls the behavior of the NSS between data frames.<br>0: NSS will stay low and serial clock will run continuously for the duration of the transfer.<br>1: NSS will toggle between consecutive data frames, with the serial clock being held to its default value while NSS is high. |
| 13        | SRL       | Shift Register Loop<br>Used for testing purposes only. When active, connects the transmit shift register output to the receive shift register input.<br>0: Disable<br>1: Enable   |
| 12        | Reserved  | Reserved, the reset value must be maintained  |
| 11:10     | TMOD[1:0] | Transfer Mode<br>00: Tx and Rx<br>01: Tx only<br>10: Rx only<br>11: EERPOM read   |
| 9         | SCPOL     | Serial Clock Polarity<br>0: low<br>1: high  |
| 8         | SCPH      | Serial Clock Phase<br>0: Capture data on the first edge of the serial clock;<br>1: Toggles one cycle after activation of the select line and captures data on the second edge of the serial clock.  |
| 7:6       | FRF[1:0]  | Frame Format<br>00: Motorola SPI<br>01: TI SSP<br>10: National Semiconductors Microwire   |

| Bit field | Name     | Description   |
|-----------|----------|---|
|           |          | 11: Reserved  |
| 5         | Reserved | Reserved, the reset value must be maintained  |
| 4:0       | DFS[4:0] | Data Frame Size<br>Selects the data frame length. When the data frame size is programmed to be less than 32 bits, the data is automatically right-aligned.<br>0x0/0x01/0x02: Reserved<br>0x03: 4bit<br>0x04: 5bit<br>0x05: 6bit<br>.....<br>0x1D: 30bit<br>0x1E: 31bit<br>0x1F: 32bit |

### 24.6.3 QSPI Control 1 Register (QSPI\_CTRL1)

Address offset: 0x04

Reset value: 0x0000 0000

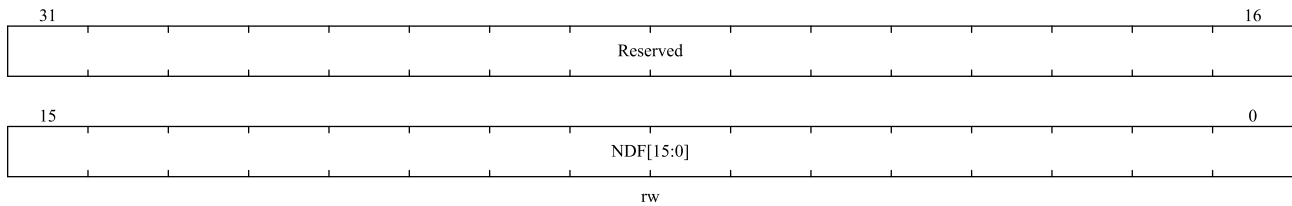

| Bit field | Name      | Description   |
|-----------|-----------|---|
| 31:16     | Reserved  | Reserved, the reset value must be maintained  |
| 15:0      | NDF[15:0] | Number of Data Frames.<br>When QSPI_CTRL0.TMOD[1:0] = 10 or 11, this register configures the number of consecutively received data frames |

### 24.6.4 QSPI Enable Register (QSPI\_EN)

Address offset: 0x08

Reset value: 0x0000 0000

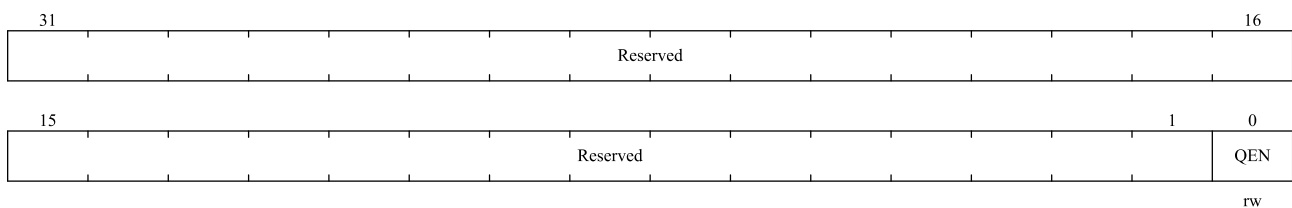

| Bit field | Name     | Description  |
|-----------|----------|--|
| 31:1      | Reserved | Reserved, the reset value must be maintained   |
| 0         | QEN      | QSPI Enable<br>0: Disabled. when QSPI is disabled, all serial transfers stop immediately.<br>1: Enable QSPI. |

### 24.6.5 QSPI Microwire Control Register (QSPI\_MW\_CTRL)

Note: This register cannot be written when the  $QSPI\_EN.QEN = 1$ .

Address offset: 0x0C

Reset value: 0x0000 0000

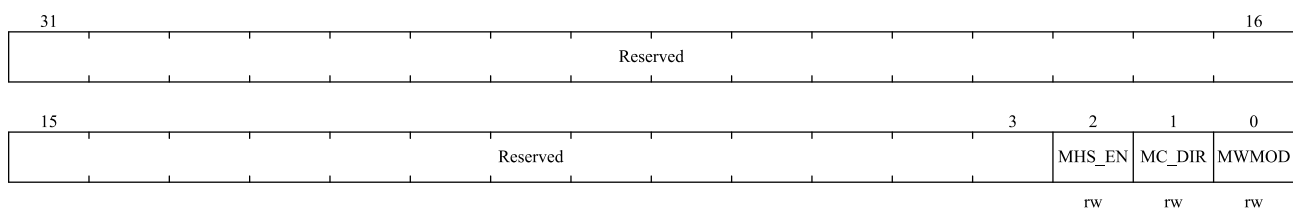

| Bit field | Name     | Description   |
|-----------|----------|---|
| 31:3      | Reserved | Reserved, the reset value must be maintained  |
| 2         | MHS_EN   | Microwire Handshaking Enable<br>0: Handshaking diable<br>1: Handshaking enable. When enabled, the QSPI checks for a ready status from the target slave, after the transfer of the last data or control bit, before clearing the QSPI_STS.BUSY status. |
| 1         | MC_DIR   | Direction of Data when Microwire Control<br>0: Rx<br>1: Tx  |
| 0         | MWMOD    | Microwire Transfer Mode<br>0: Non-Sequential Transfer. A control word must be specified for each transmitted or received block of data;<br>1: Sequential Transfer. Only one control word is required to send or receive data bytes.                   |

### 24.6.6 QSPI Slave Enable Register (QSPI\_SLAVE\_EN)

Note: Enable the  $QSPI\_EN$  register, the  $QSPI\_SLAVE\_EN$  register will be enabled for external slave device selection to enable chip select.

Address offset: 0x10

Reset value: 0x0000 0000

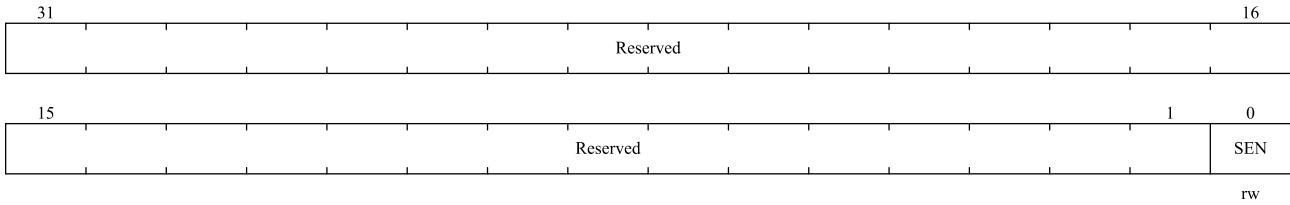

| Bit field | Name     | Description   |
|-----------|----------|---|
| 31:1      | Reserved | Reserved, the reset value must be maintained  |
| 0         | SEN      | Slave Enable<br>0: Disable<br>1: Enable<br><i>Note: You cannot write to this register when QSPI is busy and when QSPI_EN.QEN = 1.</i> |

### 24.6.7 QSPI Baud Rate Select Register (QSPI\_BAUD)

Address offset: 0x14

Reset value: 0x0000 0000

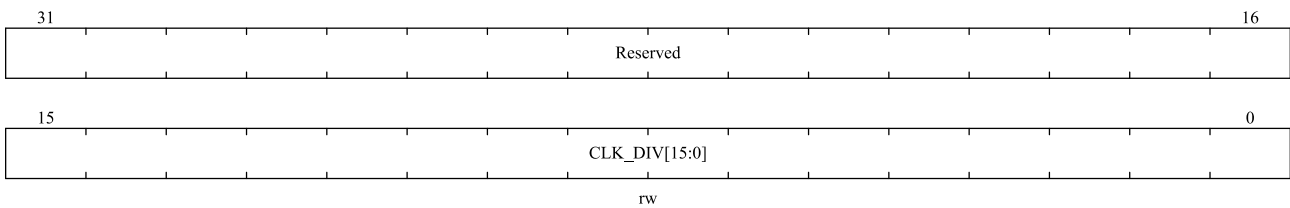

| Bit field | Name          | Description   |
|-----------|---------------|---|
| 31:16     | Reserved      | Reserved, the reset value must be maintained  |
| 15:0      | CLK_DIV[15:0] | Clock Divider<br>Bit 0 of this register is always configured as 0 and is not affected by write operations, which ensures that even values are preserved in this register. The serial output clock is disabled if CLK_DIV[15:0]=0x0000. Serial output clock frequency = AHB/CLK_DIV[15:0], the value range of CLK_DIV[15:0] is an even number between 2 and 65534. |

### 24.6.8 QSPI Transmit FIFO Threshold Level Register (QSPI\_TXFT)

Address offset: 0x18

Reset value: 0x0000 0000

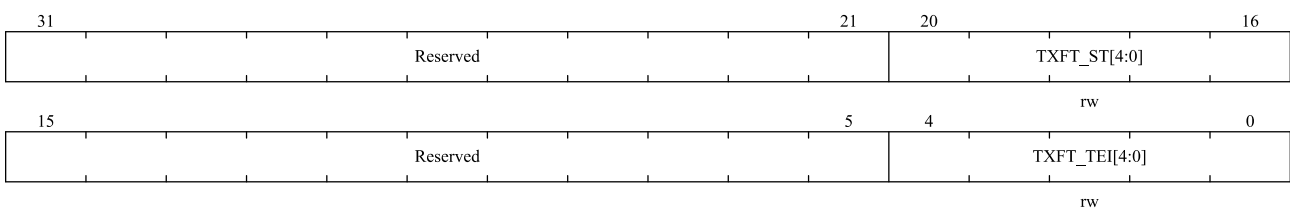

| Bit field | Name          | Description   |
|-----------|---------------|---|
| 31:21     | Reserved      | Reserved, the reset value must be maintained  |
| 20:16     | TXFT_ST[4:0]  | Transmit FIFO Threshold to Start to Transfer.<br>Tx transmission threshold, after reaching this value, start Tx transmission.   |
| 15:5      | Reserved      | Reserved, the reset value must be maintained  |
| 4:0       | TXFT_TEI[4:0] | Transmit FIFO Threshold to Trigger Empty Interrupt.<br>Tx transmission threshold, when the number of transmit FIFOs is less than this value, an empty interrupt is triggered. |

### 24.6.9 QSPI Receive FIFO Threshold Level Register (QSPI\_RXFT)

Address offset: 0x1C

Reset value: 0x0000 0000

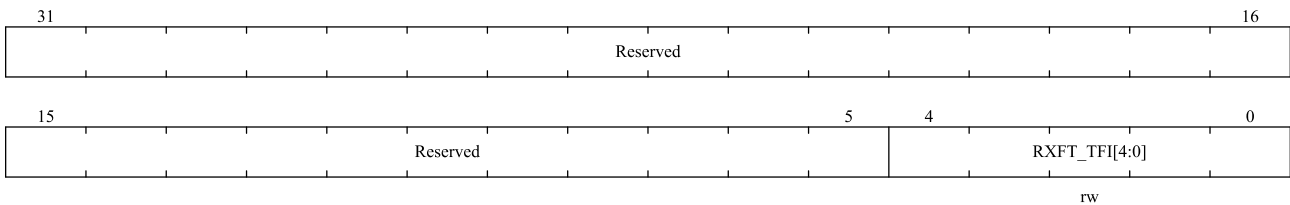

| Bit field | Name          | Description   |
|-----------|---------------|---|
| 31:5      | Reserved      | Reserved, the reset value must be maintained  |
| 4:0       | RXFT_TFI[4:0] | Receive FIFO Threshold to Trigger Full Interrupt.<br>Rx transmission threshold, when the number of receive FIFO is greater than this value plus 1, a full interrupt is triggered. |

### 24.6.10 QSPI Transmit FIFO Level Register (QSPI\_TXFN)

Address offset: 0x20

Reset value: 0x0000 0000

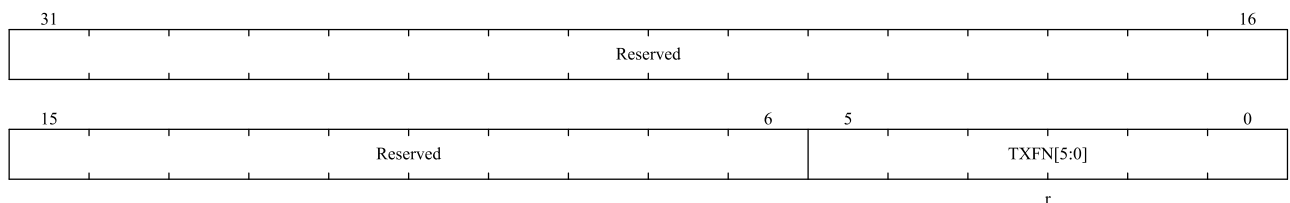

| Bit field | Name      | Description                                  |
|-----------|-----------|--|
| 31:6      | Reserved  | Reserved, the reset value must be maintained |
| 5:0       | TXFN[5:0] | Number of Transmit FIFO.                     |

### 24.6.11 QSPI Receive FIFO Level Register (QSPI\_RXFN)

Address offset: 0x24

Reset value: 0x0000 0000

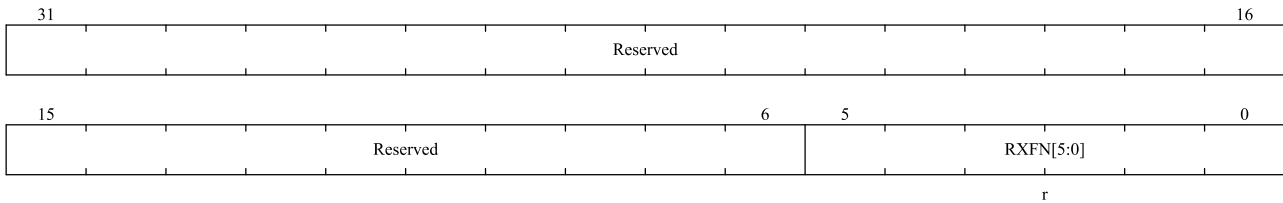

| Bit field | Name      | Description                                  |
|-----------|-----------|--|
| 31:6      | Reserved  | Reserved, the reset value must be maintained |
| 5:0       | RXFN[5:0] | Number of Receive FIFO.                      |

## 24.6.12 QSPI Status Register (QSPI\_STS)

Address offset: 0x28

Reset value: 0x0000 0006

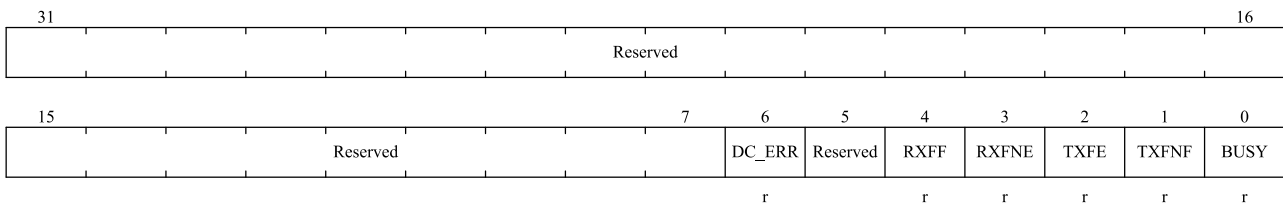

| Bit field | Name     | Description  |
|-----------|----------|--|
| 31:7      | Reserved | Reserved, the reset value must be maintained   |
| 6         | DC_ERR   | Data Conflict Error<br>0: No Error<br>1: Transmit Data Collision Error   |
| 5         | Reserved | Reserved, the reset value must be maintained   |
| 4         | RXFF     | Receive FIFO Full.<br>0: Receive FIFO is not full<br>1: Receive FIFO is full<br>When the receive FIFO is completely full, this bit is set. When the receive FIFO contains one or more empty location, this bit is cleared.         |
| 3         | RXFNE    | Receive FIFO Not Empty.<br>0: Receive FIFO is empty<br>1: Receive FIFO is not empty<br>Set when the receive FIFO contains one or more entries and is cleared when the receive FIFO is empty.                                       |
| 2         | TXFE     | Transmit FIFO Empty.<br>0: Transmit FIFO is not empty<br>1: Transmit FIFO is empty<br>When the transmit FIFO is completely empty, this bit is set. When the transmit FIFO contains one or more valid entries, this bit is cleared. |

| Bit field | Name  | Description   |
|-----------|-------|---|
| 1         | TXFNF | Transmit FIFO Not Full.<br>0: Tx FIFO is full<br>1: Tx FIFO is not Full<br>Set when the transmit FIFO contains one or more empty locations, and is cleared when the FIFO is full. |
| 0         | BUSY  | Transfer Busy Flag.<br>0: QSPI is idle or disabled<br>1: QSPI is actively transferring data   |

### 24.6.13 QSPI Interrupt Mask Register (QSPI\_IMASK)

Address offset: 0x2C

Reset value: 0x0000 007F

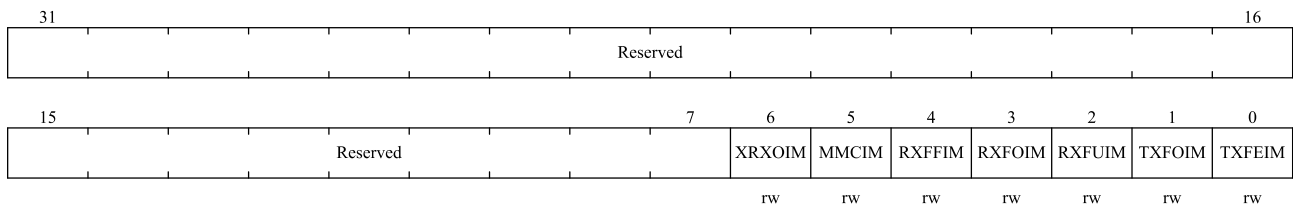

| Bit field | Name     | Description   |
|-----------|----------|---|
| 31:7      | Reserved | Reserved, the reset value must be maintained                        |
| 6         | XR XOIM  | XIP Receive FIFO Overflow Interrupt Mask.<br>0: Mask<br>1: Not mask |
| 5         | MMCIM    | Multi-Master Contention Interrupt Mask.<br>0: Mask<br>1: Not mask   |
| 4         | RXFFIM   | Receive FIFO Full Interrupt Mask.<br>0: Mask<br>1: Not mask         |
| 3         | RXFOIM   | Receive FIFO Overflow Interrupt Mask.<br>0: Mask<br>1: Not mask     |
| 2         | RXFUIM   | Receive FIFO Underflow Interrupt Mask.<br>0: Mask<br>1: Not mask    |
| 1         | TXFOIM   | Transmit FIFO Overflow Interrupt Mask.<br>0: Mask<br>1: Not mask    |
| 0         | TXFEIM   | Transmit FIFO Empty Interrupt Mask.<br>0: Mask<br>1: Not mask       |

### 24.6.14 QSPI Interrupt Status Register (QSPI\_ISTS)

Address offset: 0x30

Reset value: 0x0000 0000

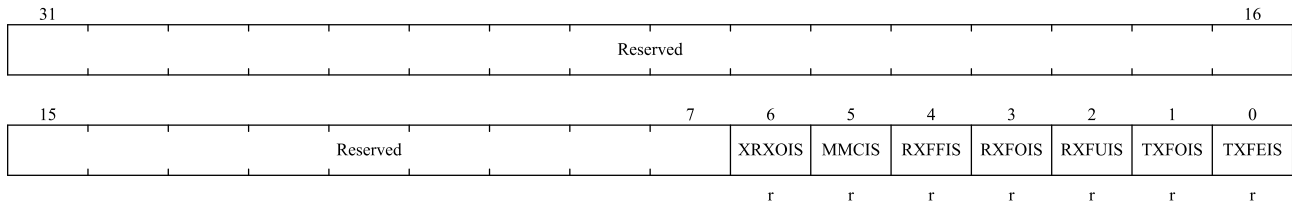

| Bit field | Name     | Description   |
|-----------|----------|---|
| 31:7      | Reserved | Reserved, the reset value must be maintained  |
| 6         | XR XOIS  | XIP Receive FIFO Overflow Interrupt Status.<br>0: Invalid, after masking.<br>1: Valid, after masking. |
| 5         | MMCIS    | Multi-Master Contention Interrupt Status.<br>0: Invalid, after masking.<br>1: Valid, after masking.   |
| 4         | RXFFIS   | Receive FIFO Full Interrupt Status.<br>0: Invalid, after masking.<br>1: Valid, after masking.         |
| 3         | RXFOIS   | Receive FIFO Overflow Interrupt Status.<br>0: Invalid, after masking.<br>1: Valid, after masking.     |
| 2         | RXFUIS   | Receive FIFO Underflow Interrupt Status.<br>0: Invalid, after masking.<br>1: Valid, after masking.    |
| 1         | TXFOIS   | Transmit FIFO Overflow Interrupt Status.<br>0: Invalid, after masking.<br>1: Valid, after masking.    |
| 0         | TXFEIS   | Transmit FIFO Empty Interrupt Status.<br>0: Invalid, after masking.<br>1: Valid, after masking.       |

### 24.6.15 QSPI Raw Interrupt Status Register (QSPI\_RISTS)

Address offset: 0x34

Reset value: 0x0000 0000

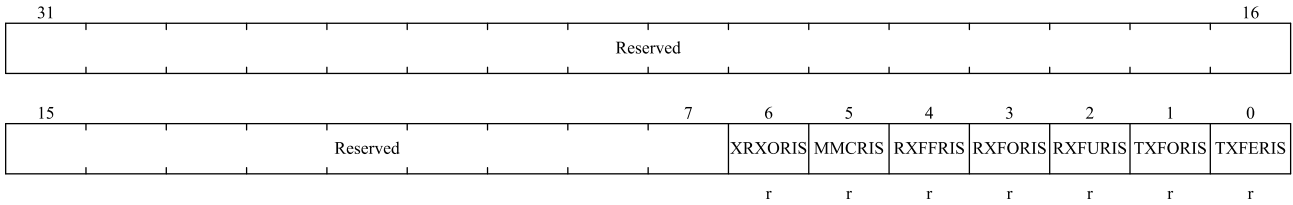

| Bit field | Name     | Description   |
|-----------|----------|---|
| 31:7      | Reserved | Reserved, the reset value must be maintained  |
| 6         | XRXORIS  | XIP Receive FIFO Overflow Raw Interrupt Status.<br>0: Invalid, prior to masking.<br>1: Valid, prior to masking. |
| 5         | MMCRIS   | Multi-Master Contention Raw Interrupt Status.<br>0: Invalid, prior to masking.<br>1: Valid, prior to masking.   |
| 4         | RXFFRIS  | Receive FIFO Full Raw Interrupt Status.<br>0: Invalid, prior to masking.<br>1: Valid, prior to masking.         |
| 3         | RXFORIS  | Receive FIFO Overflow Raw Interrupt Status.<br>0: Invalid, prior to masking.<br>1: Valid, prior to masking.     |
| 2         | RXFURIS  | Receive FIFO Underflow Raw Interrupt Status.<br>0: Invalid, prior to masking.<br>1: Valid, prior to masking.    |
| 1         | TXFORIS  | Transmit FIFO Overflow Raw Interrupt Status.<br>0: Invalid, prior to masking.<br>1: Valid, prior to masking.    |
| 0         | TXFERIS  | Transmit FIFO Empty Raw Interrupt Status.<br>0: Invalid, prior to masking.<br>1: Valid, prior to masking.       |

## 24.6.16 QSPI Transmit FIFO Overflow Interrupt Clear Register

(QSPI\_TXFOI\_CLR)

Address offset: 0x38

Reset value: 0x0000 0000

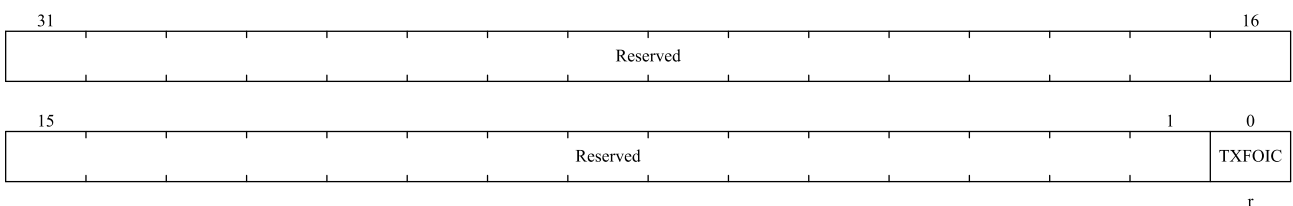

| Bit field | Name     | Description  |
|-----------|----------|--|
| 31:1      | Reserved | Reserved, the reset value must be maintained   |
| 0         | TXFOIC   | Clear Transmit FIFO Overflow Interrupt.<br>After reading this register, clear the Tx FIFO overflow interrupt status. |

### 24.6.17 QSPI Receive FIFO Overflow Interrupt Clear Register

#### (QSPI\_RXFOI\_CLR)

Address offset: 0x3C

Reset value: 0x0000 0000

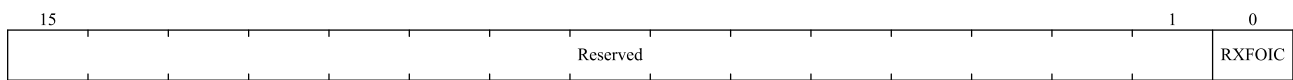
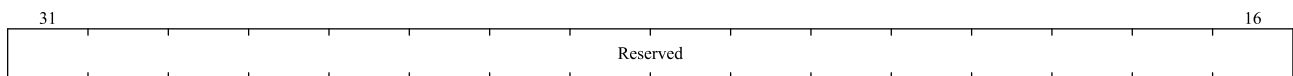

r

| Bit field | Name     | Description   |
|-----------|----------|---|
| 31:1      | Reserved | Reserved, the reset value must be maintained  |
| 0         | RXFOIC   | Clear Receive FIFO Overflow Interrupt.<br>After reading this register, clear the Rx FIFO overflow interrupt status. |

### 24.6.18 QSPI Receive FIFO Underflow Interrupt Clear Register

#### (QSPI\_RXFUI\_CLR)

Address offset: 0x40

Reset value: 0x0000 0000

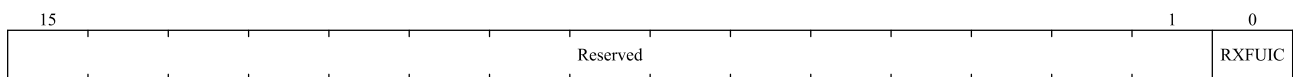
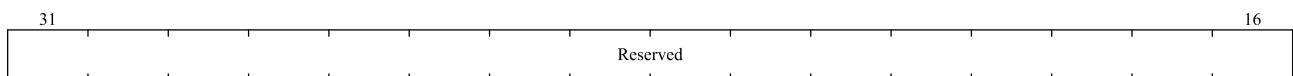

r

| Bit field | Name     | Description   |
|-----------|----------|---|
| 31:1      | Reserved | Reserved, the reset value must be maintained  |
| 0         | RXFUIC   | Clear Receive FIFO Underflow Interrupt.<br>After reading this register, clear the Rx Fifo underflow interrupt status. |

### 24.6.19 QSPI Multi-Master Interrupt Clear Register (QSPI\_MMCI\_CLR)

Address offset: 0x44

Reset value: 0x0000 0000

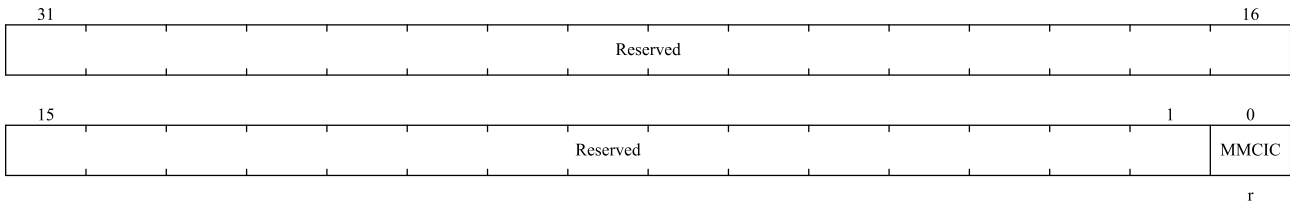

| Bit field | Name     | Description  |
|-----------|----------|--|
| 31:1      | Reserved | Reserved, the reset value must be maintained   |
| 0         | MMCIC    | Clear Multi-Master Contention Interrupt.<br>After reading this register, clear the multi-master conflict interrupt status. |

### 24.6.20 QSPI Interrupt Clear Register (QSPI\_ICLR)

Address offset: 0x48

Reset value: 0x0000 0000

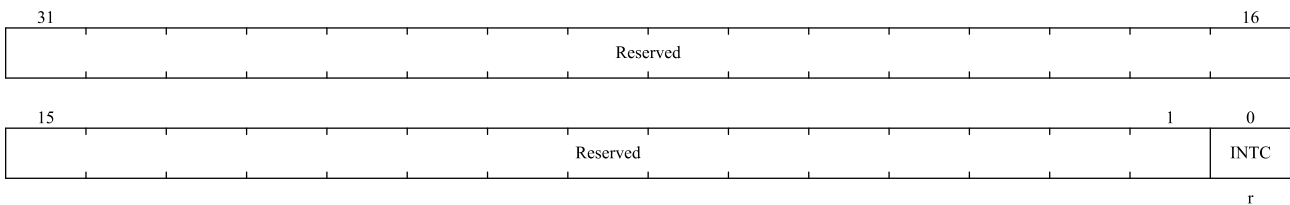

| Bit field | Name     | Description  |
|-----------|----------|--|
| 31:1      | Reserved | Reserved, the reset value must be maintained   |
| 0         | INTC     | Clear Interrupts.<br>After reading this register, clear transmit FIFO overflow interrupt, receive FIFO overflow interrupt, receive FIFO underflow interrupt, and multi-master conflict interrupt status. |

### 24.6.21 QSPI DMA Control Register (QSPI\_DMA\_CTRL)

Address offset: 0x4C

Reset value: 0x0000 0000

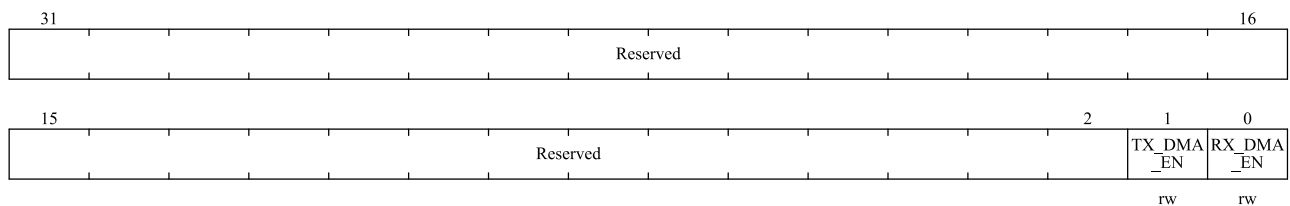

| Bit field | Name     | Description                                  |
|-----------|----------|--|
| 31:2      | Reserved | Reserved, the reset value must be maintained |

| Bit field | Name      | Description                                     |
|-----------|-----------|---|
| 1         | TX_DMA_EN | Transmit DMA Enable.<br>0: Disable<br>1: Enable |
| 0         | RX_DMA_EN | Receive DMA Enable.<br>0: Disable<br>1: Enable  |

### 24.6.22 QSPI DMA Transmit Data Level Register (QSPI\_DMATDL\_CTRL)

Address offset: 0x50

Reset value: 0x0000 0000

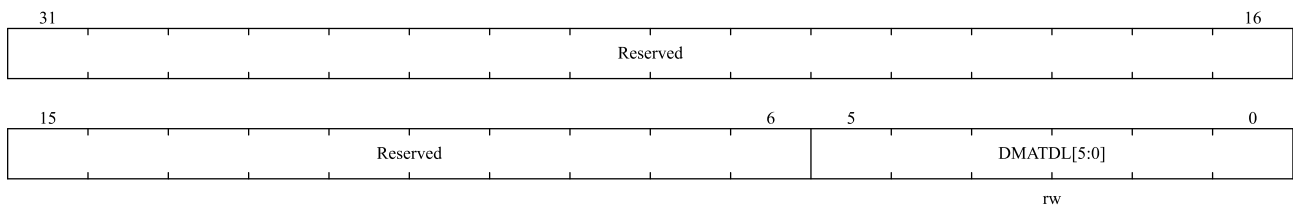

| Bit field | Name        | Description                                  |
|-----------|-------------|--|
| 31:6      | Reserved    | Reserved, the reset value must be maintained |
| 5:0       | DMATDL[5:0] | DMA Transmit Data Level.                     |

### 24.6.23 QSPI DMA Receive Data Level Register (QSPI\_DMARDL\_CTRL)

Address offset: 0x54

Reset value: 0x0000 0000

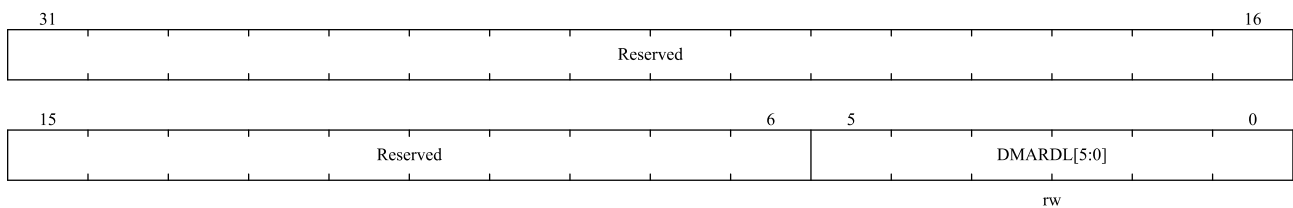

| Bit field | Name        | Description                                  |
|-----------|-------------|--|
| 31:6      | Reserved    | Reserved, the reset value must be maintained |
| 5:0       | DMARDL[5:0] | DMA Receive Data Level.                      |

### 24.6.24 QSPI Data Register (QSPI\_DATx)

Address offset: 0x60+0x04 × x (x=0~31)

Reset value: 0x0000 0000

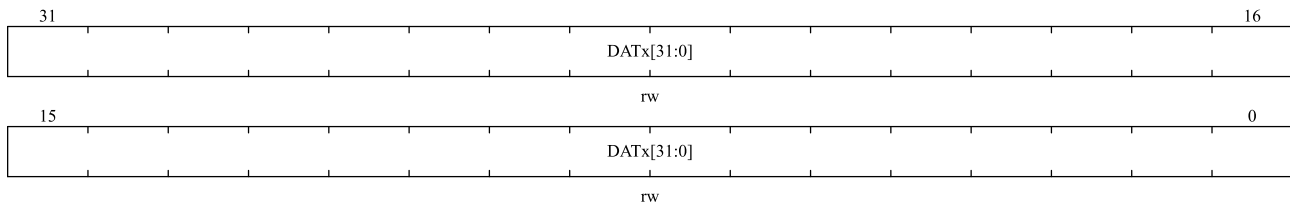

| Bit field | Name       | Description   |
|-----------|------------|---|
| 31:0      | DATx[31:0] | In the Rx state, it is the receive buffer, and the read data is automatically right-aligned; in the Tx state, it is the send buffer, and the write data must be right-aligned.<br><i>Note: a total of 32 register addresses are <math>0x60 + (0:31) \times 0x04</math>.</i> |

### 24.6.25 QSPI RX Sample Delay Register (QSPI\_RS\_DELAY)

Address offset: 0xF0

Reset value: 0x0000 0000

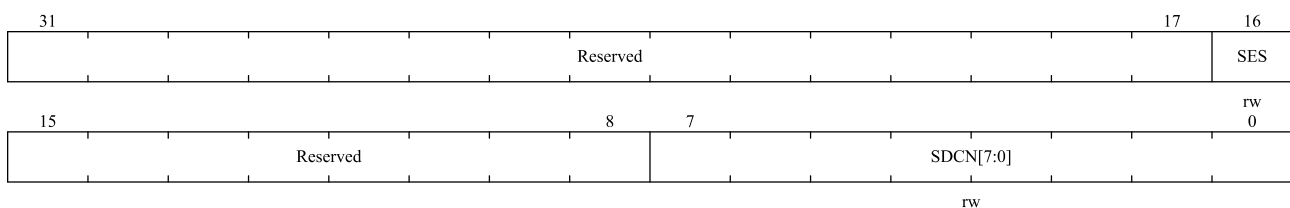

| Bit field | Name      | Description   |
|-----------|-----------|---|
| 31:17     | Reserved  | Reserved, the reset value must be maintained  |
| 16        | SES       | Sampling Edge Select of Receive Data<br>0: rising edge sampling<br>1: falling edge sampling<br><i>Note: The sampling edge selection bit configures the QSPI to sample on the rising or falling edge of the core clock AHB</i> |
| 15:8      | Reserved  | Reserved, the reset value must be maintained  |
| 7:0       | SDCN[7:0] | Sample Delay Cycle Number<br>This bit configures the number of AHB cycles to delay sampling.<br><i>Note: When 0x6 is exceeded, 0-delay sampling will be used.</i>   |

### 24.6.26 QSPI Enhanced SPI Mode Control 0 Register (QSPI\_ENH\_CTRL0)

This register is used to control serial data transfer in Enhanced SPI mode of operation. Configuring this register is valid only when  $QSPI\_CTRL0.SPI\_FRF \neq 00$ . This register cannot be written to after the  $QSPI\_EN$  register is enabled.

Address offset: 0xF4

Reset value: 0x0000 0200

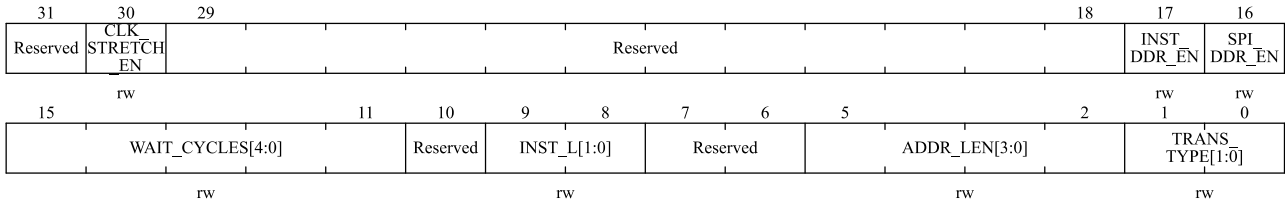

| Bit field | Name             | Description  |
|-----------|------------------|--|
| 31        | Reserved         | Reserved, the reset value must be maintained   |
| 30        | CLK_STRETCH_EN   | Clock Stretch Enable in SPI transfers.<br>In case of write, if the FIFO becomes empty QSPI will stretch the clock until FIFO has enough data to continue the transfer. In case of read, if the receive FIFO becomes full QSPI will stop the clock until data has been read from the FIFO.<br>0: Disable<br>1: Enable |
| 29:18     | Reserved         | Reserved, the reset value must be maintained   |
| 17        | INST_DDR_EN      | Instruction DDR enable bit.<br>0: Disable<br>1: Enable   |
| 16        | SPI_DDR_EN       | SPI DDR Enable bit.<br>This will enable Dual-data rate transfers in Dual/Quad frame formats of SPI<br>0: Disable<br>1: Enable  |
| 15:11     | WAIT_CYCLES[4:0] | Wait Cycles in Dual/Quad mode between control frames transmit and data reception.  |
| 10        | Reserved         | Reserved, the reset value must be maintained   |
| 9:8       | INST_L[1:0]      | Dual/Quad mode instruction length in bits.<br>00: No Instruction<br>01: 4bit<br>10: 8 bit<br>11: 16 bit  |
| 7:6       | Reserved         | Reserved, the reset value must be maintained   |
| 5:2       | ADDR_LEN[3:0]    | Length of Address to transmit.<br>0x0: No Address<br>0x1: 4bit<br>0x2: 8bit<br>0x3: 12bit<br>.....<br>0xE: 56bit<br>0xF: 60bit   |
| 1:0       | TRANS_TYPE[1:0]  | Address and instruction transfer format.<br>00: Instruction and Address will be sent in Standard SPI Mode.   |

| Bit field | Name | Description   |
|-----------|------|---|
|           |      | 01: Instruction will be sent in Standard SPI Mode and Address will be sent in the mode specified by QSPI_CTRL0.SPI_FRF.<br>10: Both Instruction and Address will be sent in the mode specified by QSPI_CTRL0.SPI_FRF.<br>11: Reserved |

### 24.6.27 QSPI DDR Transmit Drive Edge Register (QSPI\_DDR\_TXDE)

Address offset: 0xF8

Reset value: 0x0000 0000

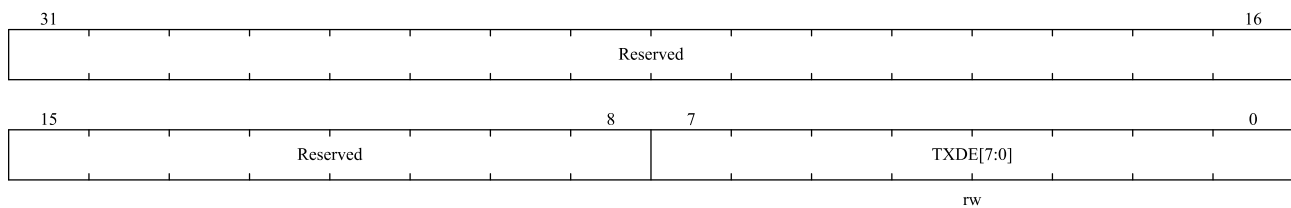

| Bit field | Name      | Description   |
|-----------|-----------|---|
| 31:8      | Reserved  | Reserved, the reset value must be maintained  |
| 7:0       | TXDE[7:0] | Transmit Drive Edge.<br>Determines the driving edge of the core clock to transmit data in DDR mode, the maximum value of this register = QSPI_BAUD/2 - 1. |

### 24.6.28 QSPI XIP Mode bits Register (QSPI\_XIP\_MODE)

Address offset: 0xFC

Reset value: 0x0000 0000

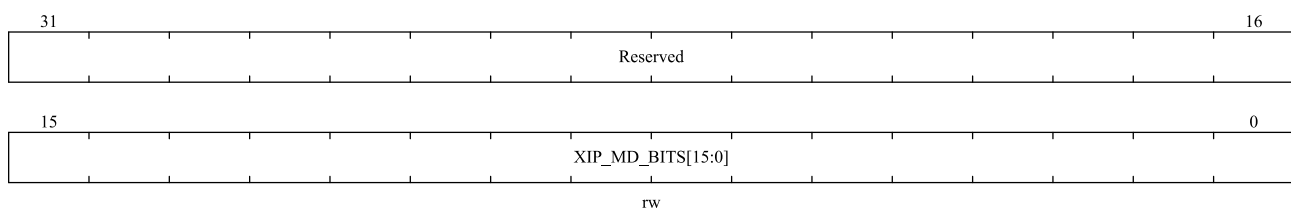

| Bit field | Name               | Description   |
|-----------|--------------------|---|
| 31:16     | Reserved           | Reserved, the reset value must be maintained                  |
| 15:0      | XIP_MD_BITS [15:0] | XIP mode bits to be sent after address phase of XIP transfer. |

### 24.6.29 QSPI XIP INCR transfer opcode Register (QSPI\_XIP\_INCR\_TOC)

Address offset: 0x100

Reset value: 0x0000 0000

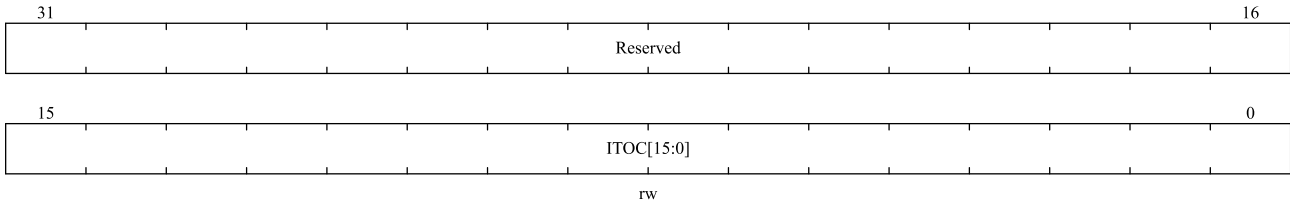

| Bit field | Name       | Description  |
|-----------|------------|--|
| 31:16     | Reserved   | Reserved, the reset value must be maintained   |
| 15:0      | ITOC[15:0] | XIP INCR transfer OpCode.<br>When QSPI_XIP_CTRL.XIP_INST_EN=1, QSPI sends XIP INCR type transmission instruction code. The number of bits to be sent during the command phase is determined by the QSPI_XIP_CTRL.INST_L field. |

### 24.6.30 QSPI XIP WRAP transfer opcode Register (QSPI\_XIP\_WRAP\_TOC)

Address offset: 0x104

Reset value: 0x0000 0000

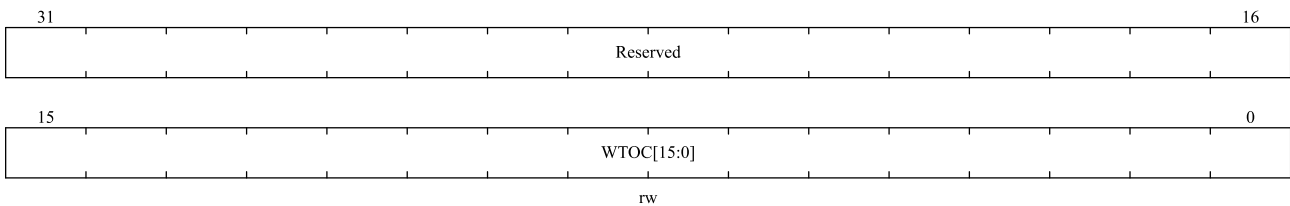

| Bit field | Name       | Description  |
|-----------|------------|--|
| 31:16     | Reserved   | Reserved, the reset value must be maintained   |
| 15:0      | WTOC[15:0] | XIP WRAP transfer OpCode.<br>When QSPI_XIP_CTRL.XIP_INST_EN=1, QSPI sends XIP WRAP type transmission instruction code. The number of bits to be sent during the command phase is determined by the QSPI_XIP_CTRL.INST_L field. |

### 24.6.31 QSPI XIP Control Register (QSPI\_XIP\_CTRL)

Address offset: 0x108

Reset value: 0x28C0 0402

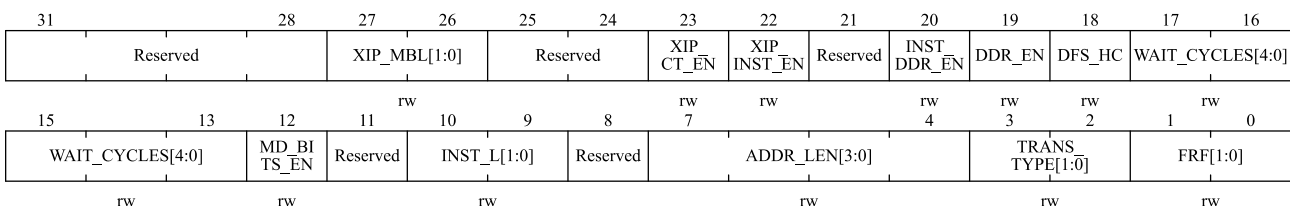

| Bit field | Name     | Description                                  |
|-----------|----------|--|
| 31:28     | Reserved | Reserved, the reset value must be maintained |

| Bit field | Name             | Description   |
|-----------|------------------|---|
| 27:26     | XIP_MBL [1:0]    | XIP Mode bits length.<br>00: Mode bits length equal to 2<br>01: Mode bits length equal to 4<br>10: Mode bits length equal to 8<br>11: Mode bits length equal to 16  |
| 25:24     | Reserved         | Reserved, the reset value must be maintained  |
| 23        | XIP_CT_EN        | Enable continuous transfer in XIP mode.   |
| 22        | XIP_INST_EN      | XIP instruction enable.<br>XIP instruction enabled. When enabled, XIP transfers will also have an instruction phase. The instruction opcode will be selected from the XIP_INCR_TOC or XIP_WRAP_TOC registers depending on the AHB transfer type.<br>0: Disable<br>1: Enable |
| 21        | Reserved         | Reserved, the reset value must be maintained  |
| 20        | INST_DDR_EN      | Instruction DDR enable bit.   |
| 19        | DDR_EN           | SPI DDR Enable bit.<br>This bit configure Dual-data rate transfers in Dual/Quad frame formats of SPI.<br>0: Disable<br>1: Enable  |
| 18        | DFS_HC           | Fix DFS for XIP transfers.<br>0: The size and number of data frames depend on the HSIZE and HBURST signals of the AHB bus<br>1: The XIP data frame size is fixed to the configuration value of QSPI_CTRL0.DFS   |
| 17:13     | WAIT_CYCLES[4:0] | Wait Cycles in Dual/Quad mode between control frames transmit and data reception.   |
| 12        | MD_BITS_EN       | Mode bits enable in XIP mode.<br>When enabled, XIP mode will insert Mode bits after the Address phase. These bits are configured in register XIP_MODE. The length of Mode bits is usually 8 bits.   |
| 11        | Reserved         | Reserved, the reset value must be maintained  |
| 10:9      | INST_L[1:0]      | Dual/Quad mode instruction length in bits.<br>00: No Instruction<br>01: 4bit<br>10: 8 bit<br>11: 16 bit   |
| 8         | Reserved         | Reserved, the reset value must be maintained  |
| 7:4       | ADDR_LEN[3:0]    | Length of Address to transmit.<br>0x0: No Address<br>0x1: 4bit<br>0x2: 8bit   |

| Bit field | Name            | Description  |
|-----------|-----------------|--|
|           |                 | 0x3: 12bit<br>.....<br>0xE: 56bit<br>0xF: 60bit  |
| 3:2       | TRANS_TYPE[1:0] | Address and instruction transfer format.<br>00: Instruction and Address will be sent in Standard SPI Mode.<br>01: Instruction will be sent in Standard SPI Mode and Address will be sent in the mode specified by QSPI_XIP_CTRL.FRF[1:0]<br>10: Both Instruction and Address will be sent in the mode specified by QSPI_XIP_CTRL.FRF[1:0].<br>11: Reserved |
| 1:0       | FRF[1:0]        | SPI Frame Format<br>00: Reserved<br>01: Dual SPI Format<br>10: Quad SPI Format<br>11: Reserved   |

### 24.6.32 QSPI XIP Slave Enable Register (QSPI\_XIP\_SLAVE\_EN)

Enable the QSPI\_EN register, the QSPI\_XIP\_SLAVE\_EN register will be enabled for external slave device selection to enable chip select.

Address offset: 0x10C

Reset value: 0x0000 0000

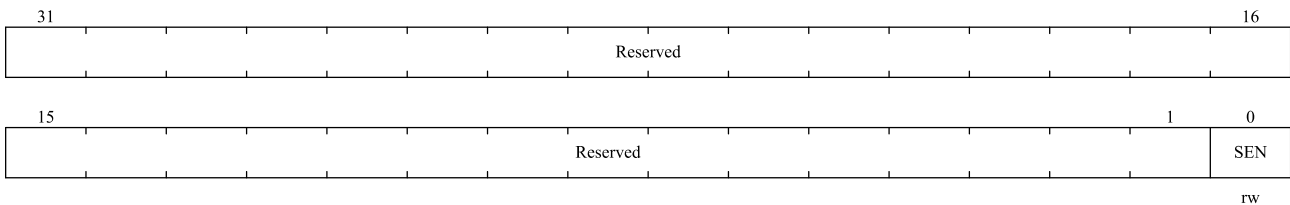

| Bit field | Name     | Description   |
|-----------|----------|---|
| 31:31     | Reserved | Reserved, the reset value must be maintained          |
| 0         | SEN      | Slave Select Enable<br>0: Not Selected<br>1: Selected |

### 24.6.33 QSPI XIP Receive FIFO Overflow Interrupt Clear Register (QSPI\_XIP\_RXFOI\_CLR)

Address offset: 0x110

Reset value: 0x0000 0000

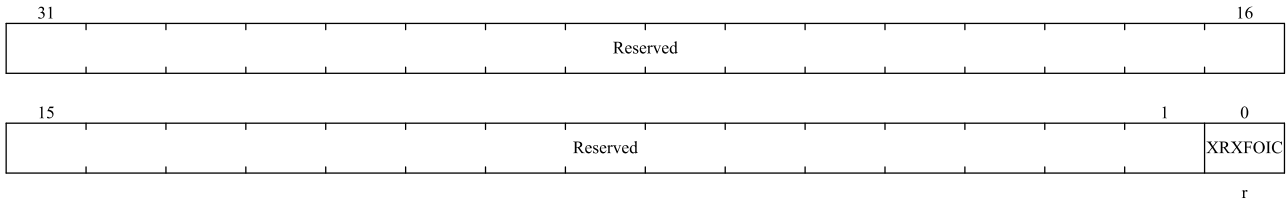

| Bit field | Name     | Description  |
|-----------|----------|--|
| 31:1      | Reserved | Reserved, the reset value must be maintained   |
| 0         | XRXFOIC  | Clear XIP Receive FIFO Overflow Interrupt.<br>After reading this register, clear the Rx FIFO overflow interrupt status |

### 24.6.34 QSPI XIP time out for continuous transfers register

#### (QSPI\_XIP\_TOUT)

Address offset: 0x114

Reset value: 0x0000 0000

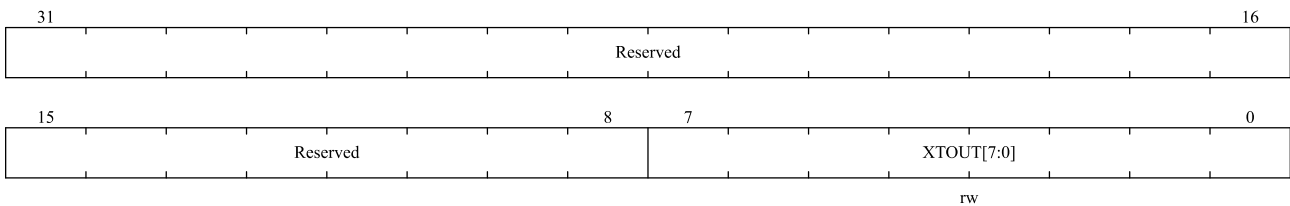

| Bit field | Name       | Description  |
|-----------|------------|--|
| 31:8      | Reserved   | Reserved, the reset value must be maintained   |
| 7:0       | XTOUT[7:0] | XIP time out value in terms of AHB.<br>XIP time out value in terms of APB. Once slave is selected in continuous XIP mode this counter will be used to de-select the slave if there is no request for the time specified in the counter |

## 25 Ethernet (ETH)

MAC: Media Access Control

MII: Media-Independent Interface

RMII: Reduced Media-Independent Interface

SMI: Station Management Interface

CSMA/CD: Carrier Sense Multiple Access/Collision Detection

SFD: Start Frame Delimiter

FCS: Frame Check Sequence

SOF: Start Of Frame

EOF: End Of Frame

*Note: Only N32G457xx series chips support Ethernet module.*

### 25.1 Introduction

Ethernet module includes a 10/100Mbps Ethernet MAC, which uses DMA to optimize the transmission and reception performance of data frames, supports MII and RMII two standard interfaces for communication with the physical layer (PHY), and realizes the transmission and reception of Ethernet data frames. Ethernet module complies with the IEEE 802.3-2008 standard and the IEEE 1588-2002 standard.

### 25.2 Main features

- Main features of Ethernet MAC:
  - ◆ Support MII/RMII interface, MII is defined in IEEE 802.3 specification, RMII conforms to RMII specification of RMII Alliance
  - ◆ Support 10/100Mbps data transfer rate
  - ◆ Support half-duplex operation:
    - CSMA/CD protocol
    - Back pressure flow control
  - ◆ Support full duplex operation:
    - IEEE 802.3x flow control
    - Forward pause control frame to application
    - When the flow control input signal fails, automatically send a zero-wait pause frame
  - ◆ Support automatic generation of CRC and PAD padding bits when transmit frames, and automatic stripping of CRC/PAD when receive frames
  - ◆ Support programmable frame length (up to 16K bytes)

- ◆ Support programmable frame gap (40~96 bits, but must be an integer multiple of 8)
- ◆ Support a variety of flexible address filtering
- ◆ Support IEEE 802.1Q VLAN tag detection for receive frames
- ◆ Support for mandatory network statistics using RMON/MIB counter (RFC2819/RFC2665)
- ◆ Support MDIO interface for configuring and managing external PHY devices
- ◆ Support to detect LAN remote wake-up frame and AMD Magic Packet™ frame two kinds of wake-up frame
- ◆ In receive function, support offloading the checksum of the received IPv4 and TCP packets encapsulated by Ethernet frames
- ◆ Support checking IPv4 header checksums, as well as checksums for TCP, UDP or ICMP (encapsulated by IPv4 or IPv6 data formats)
- ◆ Support Ethernet frame timestamps defined by the IEEE 1588-2002 standard, recording 64-bit timestamps in the frame's receive or transmit status
- ◆ Support automatic retransmission when transmit conflict, support automatic discarding of frames when late collision, excessive collision, excessive deferral and underrun
- ◆ 2 2K byte FIFOs, one is TxFIFO (for sending), the other is RxFIFO (for receiving), the threshold is configurable, the default is 64 bytes
- ◆ Support store-forward mechanism to transmit data to MAC core
- ◆ In store-forward mode, all error frames received can be filtered, but error frames are not forwarded to the application
- ◆ In store-and-forward mode, support for inserting calculated IPv4 header checksums in sent frames, as well as TCP, UDP, or ICMP checksums
- ◆ Support MII interface loopback for debugging
- Main features of Ethernet DMA:
  - ◆ AHB slave interface support all types of AHB burst transfer, AHB master interface can choose fixed or unfixed length AHB burst transfer type and address aligned burst transfer
  - ◆ Optimized packet-oriented DMA transfer with frame delimiter
  - ◆ Support addressing of data buffers in a byte-aligned manner
  - ◆ Support descriptors in double buffer (ring structure) or linked list form (chain structure)
  - ◆ Each descriptor can transmit 8K bytes of data
  - ◆ Support to echo the status information of each transmission
  - ◆ Can configure the corresponding interrupts in various working status
  - ◆ Support polling or fixed priority to arbitrate DMA transmit and receive
- PTP main features:
  - ◆ Set timestamp of received frame and transmitted frame

- ◆ Support two calibration methods: rough adjustment and fine adjustment
- ◆ Interrupt can be triggered when the system time reaches a predetermined time
- ◆ Output second pulse

## 25.3 Function block diagram

Ethernet peripheral mainly includes MAC module, MII/RMII interface module and a DMA module controlled in the form of descriptor. MAC module is connected to the off-chip PHY device through MII or RMII. MII or RMII connection method must be selected by software configuration AFIO\_RMP\_CFG.MII\_RMII\_SEL before the Ethernet controller enables the clock or in the reset state. The default configuration is MII mode. SMI interface for configuring and managing external PHY devices.

Ethernet DMA controller accesses the MAC controller through the AHB master interface to control data transfer; accesses the MAC memory through the slave interface to access the control and status register areas.

Before the MAC controller sends data, the Ethernet DMA will first read the data from the system memory area and store it in the Tx FIFO. The Ethernet frame received by the MAC controller from the bus will be first buffered in the Rx FIFO, and then transferred to the system storage area by the Ethernet DMA.

Figure 25-1 Ethernet Module Block Diagram

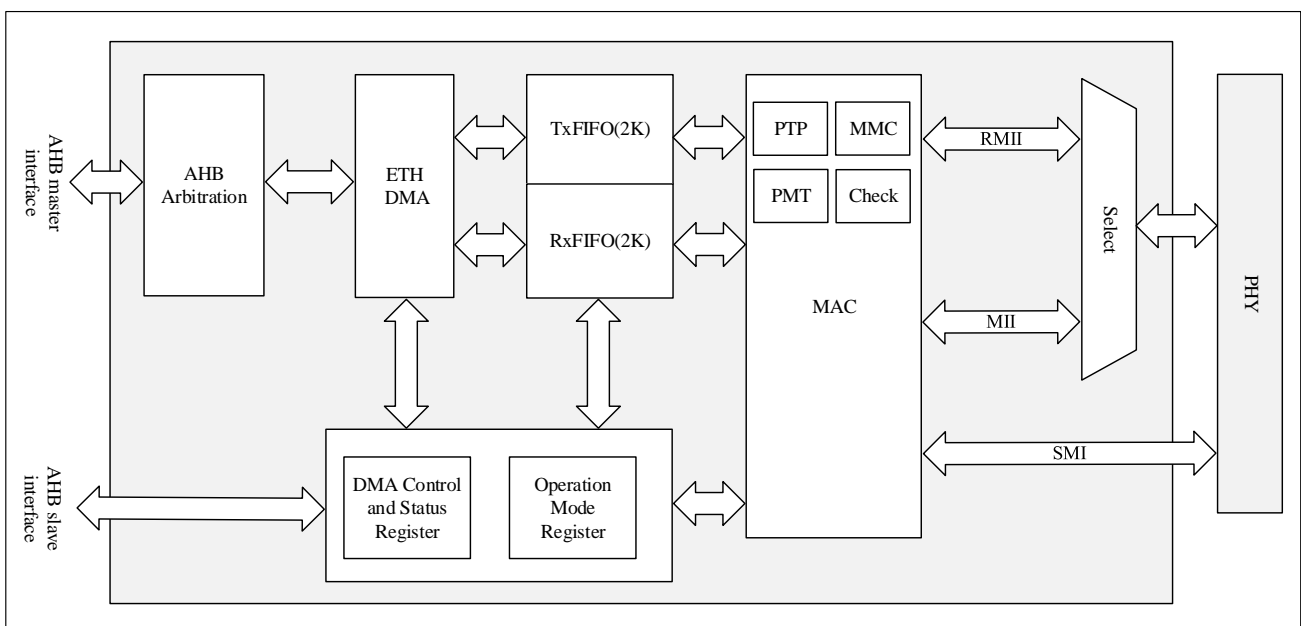

## 25.4 Function description

### 25.4.1 IEEE 802.3 ethernet frame format

There are two frame formats for the data communication of the MAC compliant with the IEEE 802.3-2008 standard:

- Basic MAC frame format (unlabeled frame)
- Tagged MAC frame format

Figure 25-2 MAC frame format and frame structure

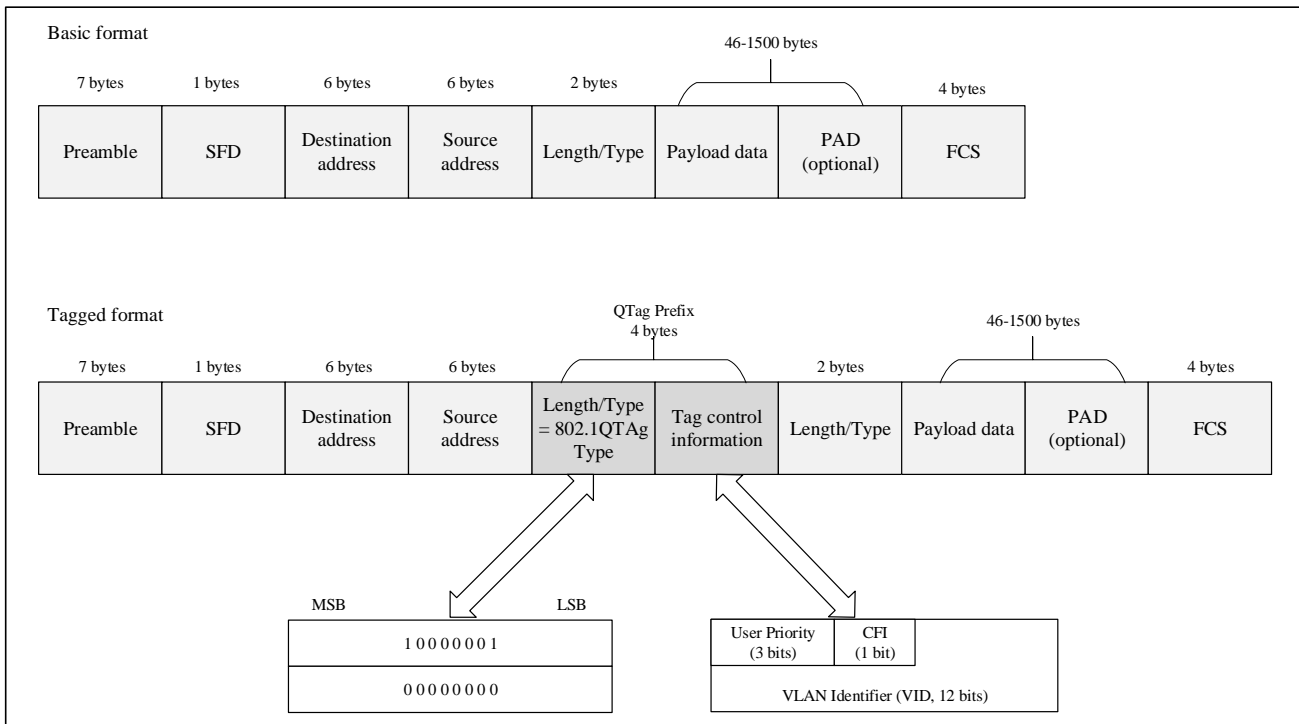

Note: Except for FCS, the Ethernet controller transmits each byte in little-endian first-out order.

CRC calculation includes all bytes of frame data except preamble and SFD. The 32-bit CRC generator polynomial of the Ethernet frame is 0x04C11DB7, and this polynomial is used for all 32-bit CRC calculations in the Ethernet module, as shown in the following formula:

$$G(x) = x^{32} + x^{26} + x^{23} + x^{22} + x^{16} + x^{12} + x^{11} + x^{10} + x^8 + x^7 + x^5 + x^4 + x^2 + x + 1$$

## 25.4.2 Pin configuration (alternate) method

Table 25-1 ETH module pin configuration (alternate)

| MII Signal | RMII Signal | Default mapping | Remap 1 | Remap 2 | Remap 3 | Pin configuration                              |
|------------|-------------|-----------------|---------|---------|---------|--|
| MDC        | MDC         | PC1             |         |         |         | Push-pull alternate output, high speed (50MHz) |
| TXD2       | -           | PC2             |         |         |         | Push-pull alternate output, high speed (50MHz) |
| Tx_CLK     | -           | PC3             |         |         |         | Input floating (reset state)                   |
| CRS        | -           | PA0             |         |         |         | Input floating (reset state)                   |
| Rx_CLK     | REF_CLK     | PA1             |         |         |         | Input floating (reset state)                   |
| MDIO       | MDIO        | PA2             |         |         |         | Push-pull alternate output, high speed (50MHz) |
| COL        | -           | PA3             |         |         |         | Input floating (reset state)                   |
| Rx_DV      | CRS_DV      | PA7             | PD8     | PA7     | PD8     | Input floating (reset state)                   |
| RxD0       | RxD0        | PC4             | PD9     | PC4     | PD9     | Input floating (reset state)                   |

| MII Signal | RMI Signal | Default mapping | Remap 1 | Remap 2 | Remap 3 | Pin configuration                              |
|------------|------------|-----------------|---------|---------|---------|--|
| RxD1       | RxD1       | PC5             | PD10    | PC5     | PD10    | Input floating (reset state)                   |
| RxD2       | -          | PB0             | PD11    | PB0     | PB0     | Input floating (reset state)                   |
| RxD3       | -          | PB1             | PD12    | PB1     | PB1     | Input floating (reset state)                   |
| Rx_ER      | -          | PB10            |         |         |         | Input floating (reset state)                   |
| Tx_EN      | Tx_EN      | PB11            |         |         |         | Push-pull alternate output, high speed (50MHz) |
| TxD0       | TxD0       | PB12            |         |         |         | Push-pull alternate output, high speed (50MHz) |
| TxD1       | TxD1       | PB13            |         |         |         | Push-pull alternate output, high speed (50MHz) |
| PPS_OUT    | PPS_OUT    | PB5             |         | PB6     |         | Push-pull alternate output, high speed (50MHz) |
| TxD3       | -          | PB8             |         | PB7     |         | Push-pull alternate output, high speed (50MHz) |

### 25.4.3 SMI interface

SMI is used to access and set the configuration of the PHY. It communicates with the external PHY through the clock line MDC and the data line MDIO, and can access any register of any PHY. SMI interface can support up to 32 PHYs, but they cannot be accessed at the same time, and only one register of one PHY can be accessed at the same time.

The functions of the clock line MDC and the data line MDIO are as follows:

- MDC: Clock signal, the highest frequency is 2.5MHz, in idle state, this pin keeps low level state. When transmitting data, the minimum holding time of the high level and low level of the signal is 160ns, and the minimum period of the signal is 400ns;
- MDIO: Receive/transmit data with the PHY, and complete the transmission with the clock line MDC.

Figure 25-3 SMI interface signal line

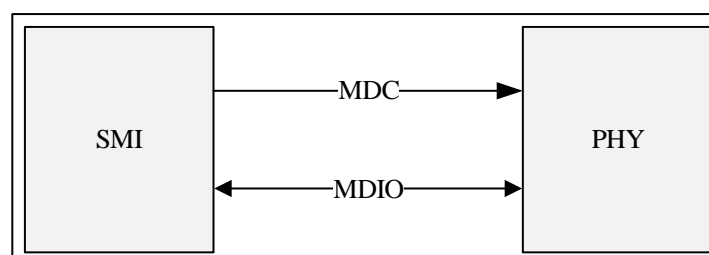

#### 25.4.3.1 SMI write operation

To implement the SMI write operation, the data to be transmitted needs to be written into the ETH\_MACMIIDAT register, and the relevant bits of the ETH\_MACMIIADDR register need to be operated:

1. Set device address and specific register address of the PHY to be operated, and set ETH\_MACMIIADDR.MW to 1 to enable the write mode;
2. Set ETH\_MACMIIADDR.MB to 1 to start transmission. The ETH\_MACMIIADDR.MB bit can be used to

judge whether the transmission is completed. During the transmission process, the ETH\_MACMIIADDR.MB bit is always high until the transmission is completed, and the hardware will automatically clear the ETH\_MACMIIADDR.MB bit. When the ETH\_MACMIIADDR.MB bit is 1, modifying the contents of ETH\_MACMIIADDR and ETH\_MACMIIDAT will be invalid.

### 25.4.3.2 SMI read operation

To implement the SMI read operation, it is necessary to operate the relevant bits of the ETH\_MACMIIADDR register:

1. Set device address and specific register address of the PHY to be operated, and set ETH\_MACMIIADDR.MW to 0 to enable the read mode;
2. Set ETH\_MACMIIADDR.MB to 1 to start receiving data. The ETH\_MACMIIADDR.MB bit can be used to judge whether the transmission is completed. When receiving data, the ETH\_MACMIIADDR.MB bit is always high. After the reception is completed, the hardware will automatically clear the ETH\_MACMIIADDR.MB bit. When the ETH\_MACMIIADDR.MB bit is 1, modifying the contents of ETH\_MACMIIADDR and ETH\_MACMIIDAT will be invalid.

*Note: The contents of the PHY registers with addresses 16-31 are customized by the manufacturer, so you need to make corresponding settings according to the PHY device manual to access this part of the registers.*

### 25.4.3.3 SMI clock configuration

The clock of SMI interface is derived from AHB clock frequency division. Set the ETH\_MACMIIADDR.CR[2:0] bits according to the AHB clock frequency, configure the appropriate frequency division factor, and ensure that the MDC clock frequency does not exceed 2.5MHz.

The SMI clock configuration ranges are as follows:

Table 25-2 SMI clock configuration range

| ETH_MACMIIADDR.CR[2:0]<br>value | MDC frequency | HCLK frequency |
|---------------------------------|---------------|----------------|
| 000                             | HCLK/42       | 60~100MHz      |
| 001                             | HCLK/62       | 100~144MHz     |
| 010                             | HCLK/16       | 20~35MHz       |
| 011                             | HCLK/26       | 35~60MHz       |

### 25.4.4 MII interface

MII is used for MAC and external PHY interconnection, and supports 10Mbps and 100Mbps data rate transmission modes.

Figure 25-4 MII interface signal line

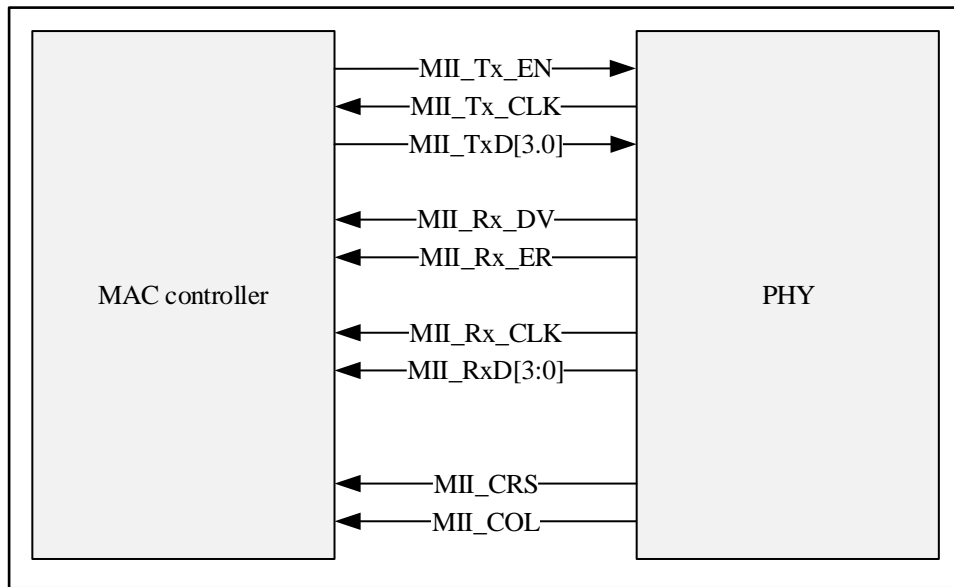

- MII\_Tx\_EN: Transmit enable signal, this signal must appear synchronously with the start bit of the data preamble, and keep it until the transmission is completed.
- MII\_Tx\_CLK: The continuous clock signal used for transmit data. When the data transmission rate is 10Mbps, the clock is 2.5MHz; when the data transmission rate is 100Mbps, the clock is 25MHz.
- MII\_TxD[3:0]: Transmit data line, transmit 4-bit data each time, the data is only valid when the MII\_Tx\_EN signal is enabled. MII\_TxD[0] is the lowest bit of the data and MII\_TxD[3] is the highest bit. When the MII\_Tx\_EN signal is disabled, the data transmitted by the PHY is invalid.
- MII\_Rx\_DV: Receive data valid signal, controlled by PHY, signal valid means PHY has prepared data for MAC to receive. This signal must appear synchronously with the first 4 bits of the frame data and remains active until the data transfer is complete. This signal must be deasserted before the first clock occurs after the last 4 bits of data have been transferred. In order to ensure that the received data is normal, the active level cannot appear after the SFD on the data line appears.
- MII\_Rx\_ER: Receive error signal, keep the valid state for at least one MII\_Rx\_CLK clock cycle, indicating that the MAC detects an error in reception. The cause of the error needs to be analyzed according to the state of MII\_Rx\_DV and the value of MII\_RxD[3:0]. Please refer to Table 25-4 for the code of the receiving interface signal.
- MII\_Rx\_CLK: The clock signal used to receive data. When the data transmission rate is 10Mbps, the clock is 2.5MHz; when the data transmission rate is 100Mbps, the clock is 25MHz.
- MII\_RxD[3:0]: Receive data line, receive 4-bit data each time, the data is valid when the MII\_Rx\_DV signal is valid. MII\_RxD[0] is the lowest bit of the data and MII\_RxD[3] is the highest bit. If MII\_Rx\_DV is invalid, but MII\_Rx\_ER is valid, MII\_RxD[3:0] data value has specific meaning, please refer to Table 25-4 for details.
- MII\_CRs: Carrier sense signal, controlled by PHY, only works in half-duplex mode. This signal is enabled when the transmitting or receiving medium is not idle. PHY must ensure that the MII\_CRs signal remains valid for the entire duration of the collision. This signal does not need to be synchronized with the transmit/receive clock.
- MII\_COL: Collision detection signal, controlled by PHY, only works in half-duplex mode. This signal is enabled

when a medium collision is detected and remains active for the duration of the collision. This signal does not need to be synchronized with the transmit/receive clock.

Table 25-3 Transmit interface signal code

| MII_Tx_EN | MII_TxD[3:0] | Explanation           |
|-----------|--------------|-----------------------|
| 0         | 0000 to 1111 | Normal frame interval |
| 1         | 0000 to 1111 | Normal data transfer  |

Table 25-4 Receive interface signal code

| MII_Rx_DV | MII_Rx_ERR | MII_RxD[3:0] | Explanation              |
|-----------|------------|--------------|--------------------------|
| 0         | 0          | 0000 to 1111 | Normal frame interval    |
| 0         | 1          | 0000         | Normal frame interval    |
| 0         | 1          | 0001 to 1101 | Reserved                 |
| 0         | 1          | 1110         | Wrong carrier indication |
| 0         | 1          | 1111         | Reserved                 |
| 1         | 0          | 0000 to 1111 | Normal data receive      |
| 1         | 1          | 0000 to 1111 | Error receiving data     |

#### 25.4.4.1 MII clock source

External PHY module needs an external 25MHz clock drive to generate the Tx\_CLK and Rx\_CLK clock signals. External 25MHz clock can be different from the MAC clock. Can use an external 25MHz crystal oscillator or configure the appropriate PLL to make the MCU clock output the 25MHz clock provided by the MCO pin.

Figure 25-5 MII clock source

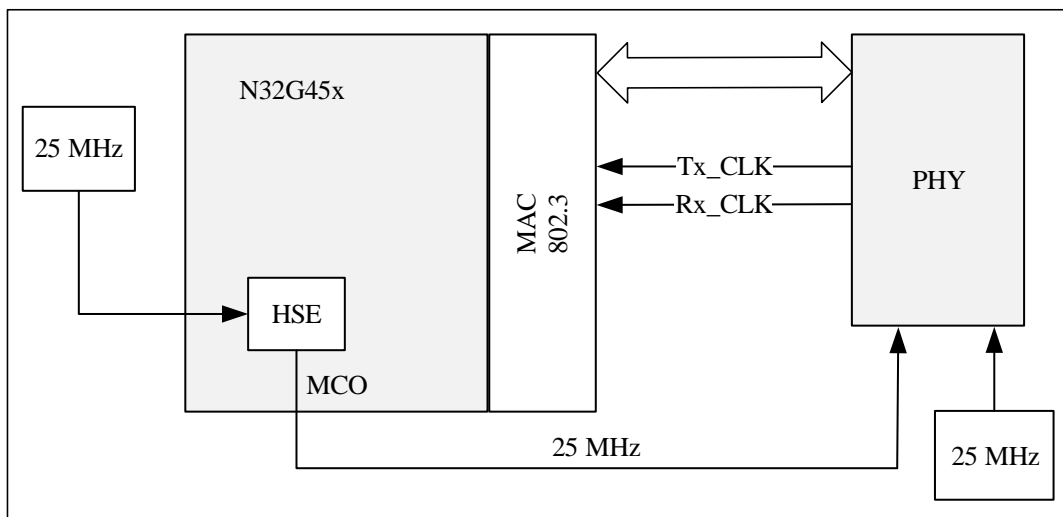

#### 25.4.5 RMII interface

The RMII specification reduces the number of pins required for communication. The IEEE802.3 standard stipulates that the MII interface requires 16 pins for data and control signals, while the RMII standard reduces the number of pins to 7.

RMII has only one clock signal of 50MHz, both MAC and external PHY need to use this clock source, and transmit and receive data are transmitted through 2-bit line width respectively.

Figure 25-6 RMIi interface signal line

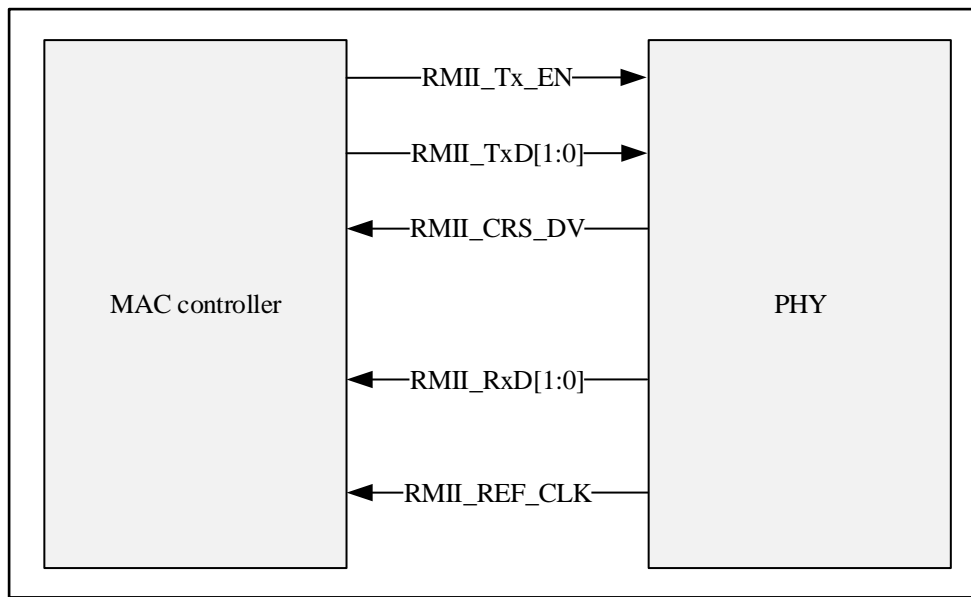

### 25.4.5.1 RMIi clock source

As shown in the figure below, an external clock source or by configuring a suitable PLL, the clock output pin MCO of the MCU can provide a 50MHz clock signal.

Figure 25-7 RMIi clock source

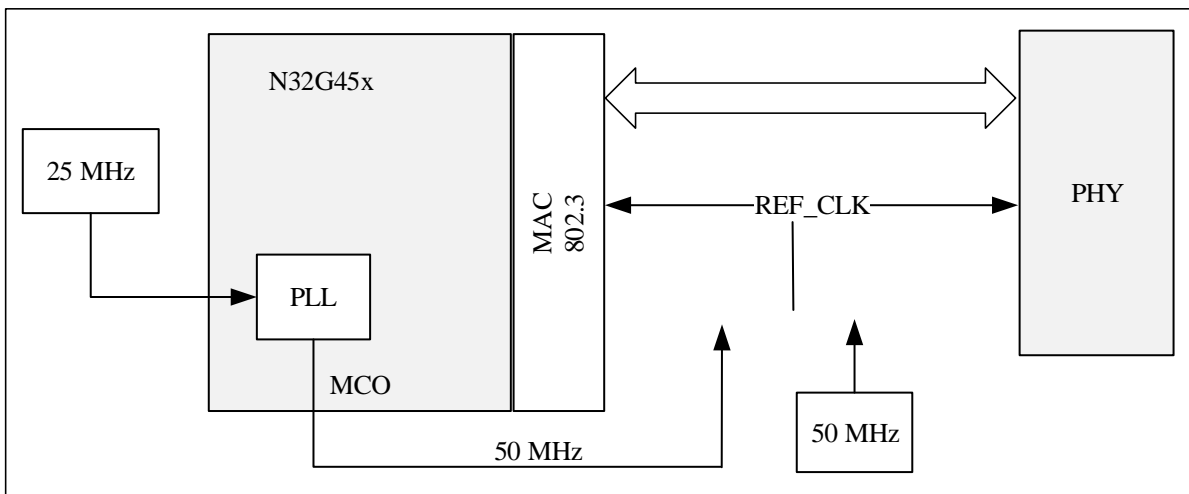

### 25.4.6 MAC function description

The MAC module performs the encapsulation of transmitted data and received data, and supports half-duplex or full-duplex working modes. Data encapsulation enables frame detection/decoding, frame boundary delimitation, addressing (managing source and destination addresses), and error detection. In half-duplex mode, the CSMA/CD algorithm is used to preempt access to the physical medium, and only two sites in one transmission direction are valid at the same time, preventing and handling conflicts for medium access management; in full-duplex mode, as long as the physical medium supports simultaneous transmit and receive operations, and only two stations that are configured in full-duplex mode access the LAN, they can transmit and receive at the same time without conflict.

### 25.4.6.1 MAC frame transmission process

The DMA controller and MAC in the Ethernet module control all Ethernet frame data transmission. After received the application transmitted instruction, DMA will read the transmit frame from the system storage area and store it in the TxFIFO with a size of 2K. According to the selected cut-through or store-and-forward mode, the data will be taken out to the MAC controller, and the data will transmit to Ethernet PHY through MII/RMII interface, optionally configured to have the MAC controller automatically add a hardware-calculated CRC value to FCS of the data frame. When the MAC controller receives the EOF signal from the TxFIFO, the transmission process ends, and the transmission status information is generated by the MAC controller and written back to the DMA controller, and the transmission status can be queried through the DMA current transmit descriptor.

There are two modes to fetch TxFIFO data to MAC controller:

- Cut-Through (Threshold) mode. When the data in the TxFIFO reaches the set threshold or the EOF is written before the threshold is reached, the data will be taken out of the TxFIFO and transmitted to the MAC controller. `ETH_DMAOPMOD.TTC` can set this threshold.
- Store-and-Forward mode. After a complete frame is written into TxFIFO, the data in TxFIFO will be transmitted to MAC controller. If the frame is not completely written into TxFIFO, that is, the size of TxFIFO is smaller than the length of the Ethernet frame to be transmitted, the data will also be transmitted to MAC controller when TxFIFO is about to be full.

### 25.4.6.2 Special case handling when frame is transmitting

When transferring data, if the `ETH_DMAOPMOD.FTF` is mis-operated, TxFIFO will be cleared (when this bit is set to 1, the data in TxFIFO will be cleared and the pointer of the TxFIFO will be reset. After the clearing operation is completed, this bit will be cleared by hardware), or if the idle DMA transmit descriptor is insufficient, the data cannot be transmitted continuously in time, and MAC controller will identify the data underflow state. If only the SOF signal is received and the EOF signal is not received, MAC will consider the SOF signal invalid, and regard this frame of data as the continuation of the previous frame of data.

If a frame of data to be transmitted occupies two DMA transmit descriptors, the first segment bit (`TDES1.FS`) and the last segment bit (`TDES1.LS`) of the first descriptor should be 10b, and the second descriptor should be 01b. If the `TDES1.FS` of the first descriptor and the second descriptor are both set, and the `TDES1.LS` of the first descriptor is reset, the `TDES1.FS` of the second descriptor will be considered invalid, and treat two descriptors as if only one frame was transmitted.

If the length of the data field of MAC frame to be transmitted is less than 46 or the length of the data field of tagged MAC frame to be transmitted is less than 42, can choose to configure MAC controller to automatically fill in data 0, make the length of the frame data field consistent with the relevant definitions of the IEEE802.3 specification. At this time, MAC will ignore the configuration of the DMA descriptor `TDES1.DC`, and automatically calculate and add the CRC value to FCS of the frame.

### 25.4.6.3 Jabber timer

The built-in Jabber timer of Ethernet will terminate the transmission of Ethernet frames after more than 2048 bytes are transmitted, to prevent the same station from occupying PHY for a long time. Jabber timer is enabled by default. If the Ethernet frame transmitted more than 2048 bytes, MAC will only transmit 2048 bytes and discard the exceeded frame data.

#### 25.4.6.4 Retransmission conflict handling mechanism

When the working mode is half-duplex, the data frame transmitted by MAC may collide. If a conflict event occurs and only frame data of no more than 96 bytes in TxFIFO is taken out to MAC, the frame retransmission function will be activated, and MAC will abort the current data transmission, read the data from TxFIFO and retransmit it. If a collision event occurs and more than 96 bytes of data are taken out of TxFIFO to MAC, MAC will abort the current transmission without activating the retransmission function and set TDES0.LC in the descriptor to notify the application.

#### 25.4.6.5 Status information word of frame transmit

After MAC controller frame transmission is completed, the transmission status information word is updated, which includes a number of transmission status flags for the application. If the timestamp function is enabled, the timestamp will be written back to the transmit descriptor along with the transmit status information word.

#### 25.4.6.6 Clear TxFIFO operation

Regardless of whether TxFIFO is popping data into MAC, as long as ETH\_DMAOPMOD.FTF is set to 1, TxFIFO is immediately emptied and TxFIFO data pointer is reset. When receiving the clear operation command, all the data taken out from TxFIFO to MAC will be discarded until the descriptor with TDES1.FS of 1 is received. The clear operation will cause MAC controller to generate a data underflow event, and end the transmission of the current frame, and return the transmission status information of the frame to the application program, and also mark the data underflow error flag (TDES0.UF) and frame clear flag (TDES0.FF). After the DMA receives all the status information words of the cleared frame, the clearing operation is completed, and ETH\_DMAOPMOD.FTF will also be automatically cleared to 0.

*Note: If the amount of received data is large, the flash function needs to be turned on, at the same time, when the receive overflow interrupt occurs, reset the ETH module and re-initialize the related data structure.*

#### 25.4.6.7 Transmit flow control

When ETH\_MACFLWCTRL.TFE is enabled and working in full-duplex mode, MAC will automatically generate and transmit Pause frames with CRC values when needed. When the software sets ETH\_MACFLWCTRL.FCB\_BPA to 1, or RxFIFO is full, it will start to generate the Pause frame and transmit the Pause frame out. The pause time specified by the Pause frame is the pause time value preset by the register ETH\_MACFLWCTRL.

- If ETH\_MACFLWCTRL.FCB\_BPA is set to 1 to request flow control, MAC will generate and transmit a single Pause frame. If want to extend the pause time, or abort the pause, need to reconfigure the pause time in the register ETH\_MACFLWCTRL and request the transmission of a new Pause frame.
- If transmit flow control is enabled, MAC will generate and transmit a Pause frame when RxFIFO is full. If the RxFIFO is still full after the configured pause time is reached, MAC will transmit another Pause frame. This process is repeated as long as RxFIFO is full. If RxFIFO is not full and the pause time has not been reached, MAC transmits a Pause frame with a pause time of 0 to inform the remote site that the local buffer is ready to receive new data frames.

#### 25.4.6.8 Transmit frame interval management

MAC manages the frame gap time (ie the time interval between two frames). When working in full-duplex mode, after the frame data transmission is completed or MAC enters the idle state, the frame gap counter starts to count. If the next transmission frame arrives before the frame gap time reaches the preset value of these bits of ETH\_MACCFG.IFG[2:0], the new transmission frame will not be transmitted until the frame gap time value is

reached. Otherwise, the frame will be transmitted immediately. When working in half-duplex mode, MAC will start the frame gap counter after the previous transmission frame is completed or MAC enters the idle state. Depending on the situation in which the carrier signal is detected, the processing is different:

1. If the carrier signal appears in the first 2/3 of the frame gap time, the frame gap counter will be reset and count again.
2. If the carrier signal appears in the last 1/3 of the frame gap time, the frame gap counter will not be reset, but continue to count until the frame gap time is reached, and MAC transmit a new frame.
3. If the carrier signal does not appear in the entire frame gap time, after the frame gap time is reached, the frame slot counter will be stopped, and if a previous frame is delayed, a new frame will be transmitted immediately.

### 25.4.6.9 Transmit checksum module

In order to ensure the reliability of transmission, Ethernet controller automatically calculates and inserts checksums when transmitting, and detects checksum errors when receiving. Only when ETH\_DMAOPMOD.TSF is configured to 1, that is, the TxFIFO is set to the store-and-forward mode, and the size of the TxFIFO can accommodate the complete data of the frame to be transmitted, the transmit checksum function can be enabled. If TxFIFO size is less than the frame length, only the checksum of the IPv4 header will be calculated and inserted.

#### ■ IP header checksum

If the value of the type field of the Ethernet frame is 0x0800, and the value of the version field of the IP packet is 0x4, the checksum module will mark it as an IPv4 data packet, and then replace the content of the checksum field of the frame with the calculation result, and write the corresponding status to TDES0.IHE.

For IPv4 data frames, TDES0.IHE is set by hardware when:

- The value of the received Ethernet type field is 0x0800, but the value of the IP header version field is not 0x4
- The value of the IPv4 header length field is greater than the total length of the frame
- The value of the IPv4 header length field is less than the total IP header length 0x5

For IPv6 data frames, its header does not contain the checksum field, so the checksum module does not change the value of the IPv6 header. TDES0.IHE is set by hardware when:

- The value of the received Ethernet type field is 0x86DD, but the value of the IP header version field is not 0x6
- The frame ends before the complete received of the IPv6 header or extension header

#### ■ TCP/UDP/ICMP checksum

The checksum module analyzes and judges the frame type (TCP, UDP or ICMP) according to the IPv4 or IPv6 header (including extension header).

The checksum module does not process the frame as follows:

- IPv4 or IPv6 frame is incomplete
- IP frame contain authentication header or encapsulate security functions such as security data
- IP frame is not TCP/UDP/ICMPv4/ICMPv6 data
- IPv6 frame with routing header

The checksum module calculates the data of TCP, UDP or ICMP, and inserts the result into the corresponding field

of the header. There are two processing methods:

1. Not included the pseudo-headers of TCP, UDP, or ICMPv6 are in the calculation. First include the checksum field in the checksum calculation, and then insert and replace the value of the original checksum field after the calculation is completed.
2. Include the pseudo-header of TCP, UDP or ICMPv6 in the calculation. First, clear the checksum field of the transmission frame to zero, and then insert the original checksum field of the transmission frame after the checksum calculation is completed.

*Note: ICMP packets over IPv4 do not define pseudo-headers. To ensure correct checksum calculation, the checksum field must have a value of 0x0000 regardless of the processing method.*

After the checksum calculation is complete, the result is written to TDES0.PCE. TDES0.PCE is set by hardware when:

- In store-and-forward mode, frames are forwarded to MAC controller before they are completely written to TxFIFO. Checksum values are not inserted into TCP, UDP, or ICMP headers.
- The frame data has been transmitted, but the data packet taken out by MAC from TxFIFO is smaller than the value indicated by the data length field in the IP header. The result of the checksum calculation will still be inserted into the corresponding field of the header.

If the packet length is greater than the indicated value, the following data will be discarded as padding bytes without reporting an error.

#### **25.4.6.10 MAC receive frame filtering**

MAC filtering includes address filtering and error filtering such as short frames, CRC errors, and bad frames. When using receive filters, it is recommended to receive data via store-and-forward mode.

##### **25.4.6.10.1 Address filter**

Address filtering is implemented by filtering static physical addresses and multicast HASH lists. If ETH\_MACFFLT.RA = 0, only the received frame that passes the address filter will be forwarded; if ETH\_MACFFLT.RA = 1, all received frame data will be forwarded, and the filtering result of the frame will still be updated in the receive descriptor, but it will not affect whether frames will be filtered. Address filtering function will filter the destination address and source address of the unicast frame or multicast frame according to the frame filter register parameters set by the application program, discard all frames that cannot pass the filter, and report the corresponding address filtering result.

##### **25.4.6.10.2 Unicast destination filter**

If ETH\_MACFFLT.HUC is set to 0, unicast filtering can be implemented by using a static physical address; if ETH\_MACFFLT.HUC is set to 1, unicast filtering can be implemented by using HASH list.

###### **■ Static physical address filtering**

MAC controller can support up to 4 MAC addresses to perfectly filter the unicast address. MAC will compare the 6-byte unicast address of the received frame with the preset MAC address register bit by bit to confirm whether they are the same. MAC address 0 register is always enabled, MAC address 1 ~ MAC address 3 registers can be enabled through their corresponding enable bits, or they can be set through ETH\_MACADDRxHI.MBC[5:0] these bits correspond to the destination address of the received frame bytes are compared.

## ■ HASH list filtering

MAC uses HASH mechanism to imperfectly filter unicast addresses using a 64-bit HASH list, which can cover any possible address with just a small table, but sometimes frames that should be discarded are also received. The filtering process is as follows:

1. MAC calculates the CRC value of the destination address of the received frame, and uses the upper 6 bits of the CRC calculation result as an index to retrieve the HASH list;
2. If the upper 6-bit value of CRC is '000000', select bit0 of the HASH list register; if the upper 6-bit value of the CRC is '111111', select bit63 of the HASH list register. If the corresponding bit is 1, the corresponding frame can pass HASH filter, otherwise it cannot pass HASH filter.

### 25.4.6.10.3 Multicast destination filter

Clear ETH\_MACFFLT.PAM to enable MAC multicast address filtering, and then configure ETH\_MACFFLT.HMC to perform different address filtering, similar to the two methods of unicast destination address filtering.

### 25.4.6.10.4 HASH or perfect address filter

Set ETH\_MACFFLT.HPF to 1, and set ETH\_MACFFLT.HUC bit for unicast frames or ETH\_MACFFLT.HMC bit for multicast frames to 1, can be realized that when the destination address of the received frame matches any one of the HASH filter or the physical address filter, the corresponding frame data is passed.

### 25.4.6.10.5 Broadcast address filter

By default, MAC will receive any broadcast frame. When ETH\_MACFFLT.DBF is set to 1, MAC will discard all received broadcast frames.

### 25.4.6.10.6 Unicast source address filter

Enable MAC address 1 ~ MAC address 3 registers and set the corresponding ETH\_MACADDRxHI.SA to 1. MAC compares and filters the physical address set in the MAC address 1 ~ MAC address 3 registers with the source address of the received frame. MAC also supports filtering of multiple source addresses. If ETH\_MACFFLT.SAF is set to 1, MAC will discard frames that cannot be filtered by the source address, and the filtering results will be reflected in the RDES0.SAF of the DMA receive descriptor. When the source address filter is working, the destination address filter is also working. As long as the frame fails to pass any filter, it will be discarded. MAC will only forward the frame that passes both the source address filter and the destination address filter to application.

### 25.4.6.10.7 Reverse filtering operation

No matter what kind of filter it is, setting ETH\_MACFFLT.DAIF and ETH\_MACFFLT.SAIF to 1 can reverse the operation at the output of the filter, that is, when the address matches the filter, the frame will not pass, otherwise it will pass. Set ETH\_MACFFLT.DAIF to reverse the filtering result of the destination address of unicast and multicast frames, and set ETH\_MACFFLT.SAIF to reverse the filtering result of the source address of unicast and multicast frames.

### 25.4.6.10.8 Promiscuous mode

Setting ETH\_MACFFLT.PRM to 1 will enable promiscuous mode. At this time, all received frames can pass the filter, the address filter is invalid, and the destination address error bit and source address error bit of the receive status information are always 0.

### 25.4.6.10.9 Pause control frame filtering

MAC will detect the 6-byte destination address field in the received control frame. If ETH\_MACFLWCTRL.UP = 0, it will judge whether the value of the destination address field is equal to 0x0180 C200 0001 (the unique value of the control frame in line with the IEEE802.3 specification); if ETH\_MACFLWCTRL.UP = 1, in addition to comparing with the unique value defined by the IEEE802.3 specification, it is also compared bit by bit with MAC address set by the controller. If the destination address field comparison is passed, and ETH\_MACFLWCTRL.RFE = 1, the corresponding pause control frame function will be triggered. According to the value set by these bits of ETH\_MACFFLT.PCF[1:0], it is determined whether the pause frame that passes the filter is forwarded to application.

### 25.4.6.11 Destination address/source address filtering result

Table 25-5 Destination address filter result list and Table 25-6 Source address filter result list show the filtering results of received frames under different settings according to the destination address filter and the source address filter.

Table 25-5 Destination address filter result list

| Frame type      | PRM | HPF | HUC | DAIF | HMC | PAM | DBF | Description of destination address filtering results  |
|-----------------|-----|-----|-----|------|-----|-----|-----|---|
| Broadcast frame | 1   | x   | x   | x    | x   | x   | x   | Pass  |
|                 | 0   | x   | x   | x    | x   | x   | 0   | Pass  |
|                 | 0   | x   | x   | x    | x   | x   | 1   | Fail  |
| Unicast frame   | 1   | x   | x   | x    | x   | x   | x   | All frames pass   |
|                 | 0   | x   | 0   | 0    | x   | x   | x   | Pass when perfect/group filter matches  |
|                 | 0   | x   | 0   | 1    | x   | x   | x   | Fail when perfect/group filter matches  |
|                 | 0   | 0   | 1   | 0    | x   | x   | x   | Pass when HASH filter matches   |
|                 | 0   | 0   | 1   | 1    | x   | x   | x   | Fail when HASH filter matches   |
|                 | 0   | 1   | 1   | 0    | x   | x   | x   | Pass when HASH or perfect/group filter matches  |
|                 | 0   | 1   | 1   | 1    | x   | x   | x   | Fail when HASH or perfect/group filter matches  |
| Multicast frame | 1   | x   | x   | x    | x   | x   | x   | All frames pass   |
|                 | x   | x   | x   | x    | 1   | x   | x   | All frames pass   |
|                 | 0   | x   | 0   | 0    | 0   | x   | x   | Pass when perfect/group filter matches, if ETH_MACFFLT.PCF = 0x, drop Pause control frame       |
|                 | 0   | 0   | 0   | 1    | 0   | x   | x   | Pass when HASH filter matches, if ETH_MACFFLT.PCF = 0x, drop Pause control frame                |
|                 | 0   | 1   | 0   | 1    | 0   | x   | x   | Pass when HASH or perfect/group filter match, if ETH_MACFFLT.PCF = 0x, drop Pause control frame |
|                 | 0   | x   | 1   | 0    | 0   | x   | x   | Fail when perfect/group filter matches, if ETH_MACFFLT.PCF = 0x, drop Pause control frame       |
|                 | 0   | 0   | 1   | 1    | 0   | x   | x   | Fail when HASH filter matches, if ETH_MACFFLT.PCF = 0x, drop Pause control frame                |
|                 | 0   | 1   | 1   | 1    | 0   | x   | x   | Fail when HASH or perfect/group filter match, if ETH_MACFFLT.PCF = 0x, drop Pause control frame |

Table 25-6 Source address filter result list

| Frame type | PRM | SAIF | SAF | Source address filtering result description |
|------------|-----|------|-----|---|
| Unicast    | 1   | x    | x   | all frames pass                             |

| Frame type | PRM | SAIF | SAF | Source address filtering result description                             |
|------------|-----|------|-----|---|
| frame      | 0   | 0    | 0   | Pass when perfect/group filter matches, but don't drop frames that fail |
|            | 0   | 1    | 0   | Fail when perfect/group filter matches, but don't drop frames           |
|            | 0   | 0    | 1   | Pass when perfect/group filter matches, drop frames that fail           |
|            | 0   | 1    | 1   | Fail when perfect/group filter matches, drop frames that fail           |

#### 25.4.6.12 MAC frame receive process

As soon as MAC detects an SFD on the interface, the receive procedure is initiated. After MAC receives the frame, it strips its preamble and SFD first, then filters it through the header, and checks the CRC value of the frame with FCS. If the IEEE1588 timestamp is enabled, MAC will record the current time of the system while detecting the SFD of the frame. If the frame passes the address filter check, MAC will transmit the timestamp to the application along with the DMA receive descriptor, otherwise the frame will be discarded. After the receiving engine starts, it will start from the first byte (destination address) after the SFD and send data frames to the RxFIFO.

If ETH\_MACCFG.ACS is set and the value of the received frame length/type field is less than 0x600, MAC will automatically strip the PAD and FCS. After the number of bytes transmitted by MAC to RxFIFO reaches the value of the frame length/type field, all remaining bytes (including FCS) are discarded. If the value of the length/type field is greater than or equal to 0x600, regardless of whether the automatic CRC stripping option is enabled, MAC will transmit all received Ethernet frame data to RxFIFO.

If the watchdog timer is enabled (ETH\_MACCFG.WD is reset), it will be cut off when the frame length exceeds 2048 bytes (destination address + source address + length/type + data + PAD + FCS). Even if the watchdog timer is disabled, MAC will still cut off frames longer than 16384 bytes.

When RxFIFO works in the cut-through (threshold) mode, if the amount of data in RxFIFO is greater than the threshold set by these bits of ETH\_DMAOPMOD.RTC[1:0], it will start to take out data from RxFIFO and notify DMA. When the complete frame is fetched from RxFIFO, MAC controller transmit the receive status information word to DMA controller and writes it back to the receive descriptor. If a frame has started to be taken out of RxFIFO and carried by DMA to the application, even if an error is detected, the frame will continue to be received until the entire frame is received. Since the error information will not be transmitted to DMA controller until this time, the first part of the frame has been read by DMA, so setting MAC to discard all error frames in this mode will have no effect.

When setting ETH\_DMAOPMOD.RSF to make RxFIFO work in store-and-forward mode, DMA will only read out a frame after RxFIFO has received a complete frame. If MAC is set to discard all erroneous frames, then DMA will only read out legitimate frames and forward them to application.

#### 25.4.6.13 Receive of multiple frames

Different from TxFIFO, since the status information of the frame follows the frame data, MAC can judge the status of the received frame according to the frame status information immediately after the frame data, so the transmission of the second received frame is immediately followed by the data and status information of the first received frame, as long as RxFIFO is not full, any number of frames can be stored.

#### 25.4.6.14 Receive flow control

When working in full-duplex mode, can set ETH\_MACFLWCTRL.RFE to enable or disable the Pause frame detection function. If the Pause frame detection is enabled, MAC can decode the received Pause frame, identify the type field, operand field and pause time field, and transmit it after a certain period of time according to the parameters

of the pause time field in the Pause frame. During a pause, if a new Pause frame is received, the new pause time will be loaded into the pause time counter immediately. If the value of the received pause time field is 0, MAC will stop the pause time counter and resume data transmission. Determine how these received control frames are handled by configuring these bits in ETH\_MACFFLT.PCF[1:0]. If the Pause frame detection function is disabled, MAC will ignore the received Pause frame.

#### 25.4.6.15 Receive frame error handling

- If RxFIFO is full before MAC receives the EOF, MAC controller will drop the entire frame and return to the overflow state, and the overflow counter will be incremented accordingly.
- If RxFIFO works in store-and-forward mode, MAC filter and discard all error frames, but by setting ETH\_DMAOPMOD.FEF and ETH\_DMAOPMOD.FUF, RxFIFO can still receive error frames and frames whose length is lower than the minimum frame length.
- If RxFIFO works in the cut-through (threshold) mode, all error frames cannot be dropped. Only when DMA reads the SOF of the frame from RxFIFO and RxFIFO obtains the error status of the frame, the error frame can be dropped.

#### 25.4.6.16 Receive frame status information word

After receiving the Ethernet frame, MAC will analyze and record the frame itself and some status information in the receiving process, and write the receiving status information back to the DMA receive descriptor and related status flags. Applications can utilize these status bits to implement upper layer protocols.

*Note: The frame length value of 0 indicates that the frame written to RxFIFO is incomplete, such as RxFIFO overflows or the value of the filter is dynamically modified during the receiving process, resulting in failure to pass the filter.*

#### 25.4.6.17 Receive checksum module

Set ETH\_MACCFG.IPC to enable the receive checksum module. The receive checksum module can calculate the checksum of the IPv4 header and check that it matches the contents of the checksum field of the IPv4 header. If the received Ethernet frame type field value is 0x0800, the frame is an IPv4 frame; if the received Ethernet frame type field value is 0x86DD, the frame is an IPv6 frame.

RDES0.ICEGF is set to 1 when the received IP header:

- The calculated checksum value of IPv4 header does not match the content of its checksum field
- The data type indicated by Ethernet type field does not match IP header version field
- The received frame length is less than the length indicated by IPv4 header length field, or IPv4/IPv6 header is less than 20 bytes

The receiving checksum module can determine whether the data type of the IP packet is TCP, UDP or ICMP, and calculate their checksum according to their respective specifications, including the data of TCP/UDP/ICMPv6 pseudo-header.

RDES0.RMAPCE is set to 1 when the received IP packet:

- The calculated TCP, UDP or ICMP checksum does not match the value of the checksum field of its frame
- The received TCP, UDP or ICMP data length does not match the length indicated by IP header

The receive checksum module does not calculate if IP packet is incomplete or with security features, IPv6 routing headers, and data types other than TCP, UDP, or ICMP.

#### **25.4.6.18 MAC loopback mode**

Loopback mode is disabled by default, which is generally used for application testing and debugging of system hardware and software. Set `ETH_MACCFG.LM` to 1 to enter MAC loopback mode, and MAC will transmit data by itself and receive it by itself, that is, the sender transmit the frame to its own receiver.

#### **25.4.6.19 MAC management counter (MMC)**

MMC is a management counting unit that uses a set of registers to count the sent and received frames. See Section 25.5.22 ~ Section 25.5.32 for the specific function of each register and the address of each statistic counter. These addresses can be used to read/write access to the required transmit/receive counters.

If there is no frame underflow, no carrier, carrier loss, excessive deferral, late collision, excessive collision, or Jabber timeout error in the transmitted frame, it is considered that the transmission process is normal, and MMC transmission counter will be automatically updated.

If the received frame is not aligned, CRC calculation result is inconsistent with the FCS value, the frame length is less than 64 bytes, the value of the length field does not match the actual number of bytes received, exceeds the range, and the `MII_Rx_ER` input is incorrect, the receiving process is considered normal. MMC receive counter is automatically updated. In addition, if the destination address is not received completely and the length of the discarded frame is less than 6 bytes, MMC reception counter will also be updated.

*Note: The maximum range is 1518 bytes for basic frame and 1522 bytes for tagged frame (VLAN frames) (both with preamble and SFD stripped).*

### **25.4.7 Power management (PMT)**

Ethernet module supports two methods to wake up the system from low power mode: Remote Wakeup Frame and Magic Packet Wakeup Frame. To reduce power consumption, the host system and Ethernet module can be put into a low-power state and listen for wake-up frames. If `ETH_MACPMTCTRLSTS.PWRDWN` is set to 1, Ethernet module will enter a low-power state, and MAC will discard all frames until it receives a remote wake-up frame or a Magic Packet wake-up frame to exit the low-power state. Set `ETH_MACPMTCTRLSTS.RWKPKTEN` to 1 to wake up the Ethernet module when a remote wake-up frame is received; set `ETH_MACPMTCTRLSTS.MGKPKTEN` to 1 to wake up the Ethernet module when a Magic Packet wake-up frame is received. Any wake-up function is enabled, as long as MAC receives the corresponding wake-up frame, Ethernet module will generate a wake-up interrupt and exit the low-power state.

#### **25.4.7.1 Remote wakeup frame filter register**

The wake-up frame filter has 8 registers that share the same offset address. When the reading or writing of a filter register is completed, the internal pointer will automatically point to the next filter register. Whether it is a read operation or a write operation, it is strongly recommended to operate 8 times continuously, that is, when setting the register, need to divide the set value into 8 times and write the wake-up frame filter register address one by one, and read the wake-up frame filter register 8 times continuously to read the value of the register.

Table 25-7 Remote wakeup frame filter register overview

| Register                       | 31                 | 30 | 29 | 28 | 27               | 26 | 25 | 24 | 23              | 22 | 21 | 20 | 19               | 18 | 17 | 16 | 15              | 14 | 13 | 12 | 11               | 10 | 9 | 8 | 7               | 6 | 5 | 4 | 3                | 2 | 1 | 0 |
|--------------------------------|--------------------|----|----|----|------------------|----|----|----|-----------------|----|----|----|------------------|----|----|----|-----------------|----|----|----|------------------|----|---|---|-----------------|---|---|---|------------------|---|---|---|
| Wakeup frame filter register 0 | Filter 0 byte mask |    |    |    |                  |    |    |    |                 |    |    |    |                  |    |    |    |                 |    |    |    |                  |    |   |   |                 |   |   |   |                  |   |   |   |
| Wakeup frame filter register 1 | Filter 1 byte mask |    |    |    |                  |    |    |    |                 |    |    |    |                  |    |    |    |                 |    |    |    |                  |    |   |   |                 |   |   |   |                  |   |   |   |
| Wakeup frame filter register 2 | Filter 2 byte mask |    |    |    |                  |    |    |    |                 |    |    |    |                  |    |    |    |                 |    |    |    |                  |    |   |   |                 |   |   |   |                  |   |   |   |
| Wakeup frame filter register 3 | Filter 3 byte mask |    |    |    |                  |    |    |    |                 |    |    |    |                  |    |    |    |                 |    |    |    |                  |    |   |   |                 |   |   |   |                  |   |   |   |
| Wakeup frame filter register 4 | Reserved           |    |    |    | Filter 3 command |    |    |    | Reserved        |    |    |    | Filter 2 command |    |    |    | Reserved        |    |    |    | Filter 1 command |    |   |   | Reserved        |   |   |   | Filter 0 command |   |   |   |
| Wakeup frame filter register 5 | Filter 3 offset    |    |    |    |                  |    |    |    | Filter 2 offset |    |    |    |                  |    |    |    | Filter 1 offset |    |    |    |                  |    |   |   | Filter 0 offset |   |   |   |                  |   |   |   |
| Wakeup frame filter register 6 | Filter 1 CRC-16    |    |    |    |                  |    |    |    |                 |    |    |    |                  |    |    |    | Filter 0 CRC-16 |    |    |    |                  |    |   |   |                 |   |   |   |                  |   |   |   |
| Wakeup frame filter register 7 | Filter 3 CRC-16    |    |    |    |                  |    |    |    |                 |    |    |    |                  |    |    |    | Filter 2 CRC-16 |    |    |    |                  |    |   |   |                 |   |   |   |                  |   |   |   |

#### ■ Filter n byte mask

This register defines which part of the frame is used by filter n (n = 0, 1, 2, 3) to determine whether it is a wake-up frame. Bit 31 of this register is fixed at 0, and bits[30:0] are byte mask bits. Only if the mth bit (m = 0~30) of filter n (n = 0, 1, 2, 3) is 1, CRC module of wake-up frame detection will process the input frame [filter n offset + m] bytes, otherwise ignored and not processed.

#### ■ Filter n command

A total of 4 bits control the working mode of filter n. The third part of this register is the address type selection. If this bit is 1, only multicast frames are detected; if this bit is 0, only unicast frames are detected. Bit 2 and bit 1 are fixed to 0. Bit 0 is the enable bit of filter n. When set, filter n is enabled, otherwise, filter n is disabled.

#### ■ Filter n offset

Filter n offset defines the offset within the frame of the first byte to be checked by filter n, used in conjunction with the filter n byte mask. The minimum allowed value of the offset value is 12, which represents the 13th byte of the frame (the offset value of 0 represents the first byte of the frame).

#### ■ Filter n CRC-16

When the filter n is offset and the corresponding byte mask is 1, this register with a preset CRC-16 code is used for comparison with the CRC-16 value calculated by the frame data (generator polynomial is 0x8005).

### 25.4.7.2 Remote wakeup frame detection

Set ETH\_MACPMTCTRLSTS.RWKPKTEN to 1 to enable detection of remote wakeup frames. PMT module supports 4 programmable filters, allowing different receive frame modes to be supported. If the received frame passes the address filtering of the filter command, and the filter CRC-16 matches the CRC of the incoming frame, MAC identifies the frame as a wake-up frame. The Remote Wakeup CRC field determines the CRC value to compare with the filter CRC-16. PMT module only checks whether the length of the remote wake-up frame is wrong, whether FCS

is wrong, whether Dribble bit is wrong, whether MII is wrong, whether there is a collision, and ensuring that the remote wake-up frame is not a stub frame. Even if the length of the remote wake-up frame exceeds 512 bytes, if the frame has a valid CRC value, it is still considered a valid wake-up frame. ETH\_MACPMTCTRLSTS.RWKPRCVD is set whenever a remote wakeup frame is detected. A remote wakeup frame wakeup interrupt will also be generated if ETH\_MACPMTCTRLSTS.RWKPKTEN is enabled.

### 25.4.7.3 Magic Packet detection

Setting ETH\_MACPMTCTRLSTS.MGKPKTEN to 1 enables detection of Magic Packet wakeup frames. A Magic Packet frame is a specially constructed data packet dedicated to wake-up that can be received, analyzed and recognized by the Ethernet module and triggers a wake-up event. The frame format of the Magic Packet wake-up frame is as follows: 6 bytes of all 1 (0xFFFF FFFF FFFF) at any position after the destination address and source address fields, followed by 16 repeated MAC addresses without any interruption and pause; If there are any gaps between these 16 repetitions, need to recheck 0xFFFF FFFF FFFF in the input frame. PMT module will always monitor each frame sent to this node. MAC will filter the Magic Packet frame by address first, and then check whether it conforms to the format of Magic Packet. If it conforms, it will wake up MAC from a low-power state. Both unicast and multicast frames can be used as Magic Packet frames.

The following is an example of a Magic Packet frame with station address 0xAABB CCDD EEFF:

```
Destination address Source address.....FF FF FF FF FF FF
AABB CCDD EEFF AABB CCDD EEFF AABB CCDD EEFF AABB CCDD EEFF
AABB CCDD EEFF AABB CCDD EEFF AABB CCDD EEFF AABB CCDD EEFF
AABB CCDD EEFF AABB CCDD EEFF AABB CCDD EEFF AABB CCDD EEFF
AABB CCDD EEFF AABB CCDD EEFF AABB CCDD EEFF AABB CCDD EEFF
.....CRC
```

ETH\_MACPMTCTRLSTS.MGKPRCVD will be set whenever a Magic Packet frame is detected. Magic Packet wakeup interrupt will also be generated if ETH\_MACPMTCTRLSTS.MGKPKTEN is enabled.

### 25.4.7.4 Considerations when system is in low-power mode

If the external interrupt line 19 is enabled, Ethernet PMT module can also detect frames when MCU is in low-power mode. ETH\_MACCFG.RE must be kept as 1 to ensure that MAC also performs Magic Packet/remote wake-up frame detection in a low-power state. In order to reduce power consumption, it is necessary to clear ETH\_MACCFG.TE to close the transmission engine in the low-power consumption state, and to close Ethernet DMA module by setting ETH\_DMAOPMOD.ST and ETH\_DMAOPMOD.SR (corresponding to TxDMA and RxDMA respectively) to 0.

It is recommended to perform the following steps to enter low-power state and wake up:

1. Wait for the transmission of the current frame to complete, then reset ETH\_DMAOPMOD.ST to turn off TxDMA;
2. Clear ETH\_MACCFG.TE and ETH\_MACCFG.RE, close MAC transmit engine and MAC receive engine;
3. By reading ETH\_DMASTS.RI, make sure to wait for RxDMA to read all frames in Rx FIFO before closing RxDMA;
4. Configure and enable external interrupt line 19 to generate events or interrupts. If external interrupt line 19 is configured to generate an interrupt, also need to write the interrupt handler ETH\_WKUP\_IRQHandler, and clear

the interrupt flag bit of external interrupt line 19 in interrupt handler;

5. Set ETH\_MACPMTCTRLSTS.MGKPKTEN to 1 to enable detection of Magic Packet wakeup frames or set ETH\_MACPMTCTRLSTS.RWKPKTEN to 1 to enable detection of remote wakeup frames;
6. Set ETH\_MACPMTCTRLSTS.PWRDWN to 1 to enable low-power consumption mode;
7. Set ETH\_MACCFG.RE to 1, open MAC receive engine;
8. Configure MCU to enter the relevant low-power mode;
9. After received a valid wake-up frame, Ethernet module exits low-power state;
10. Read ETH\_MACPMTCTRLSTS register to clear power management event flag, turn on MAC transmit engine, and TxDMA and RxDMA;
11. Set system clock, enable HSE and configure RCC clock parameters to restore system to normal state.

## 25.4.8 Ethernet DMA function description

The dedicated DMA controller of Ethernet module can realize the frame data transmission between FIFO and system storage, reducing the intervention of CPU. The communication between DMA and CPU is achieved through 2 data structures:

- Descriptor list (chain or ring) and data buffer
- Control and Status register

The application needs to allocate a list of storage descriptors and physical memory for data caching. Contains two descriptor queues for transmitting and receiving respectively, and the descriptors are stored in the memory in the form of pointers to the buffer. The base address of the transmit descriptor queue is stored in ETH\_DMATXDLADDR register, and the transmit descriptor is composed of four descriptor words TDES0-TDES3; the base address of the receive descriptor queue is stored in ETH\_DMARXDLADDR register, and the receive descriptor is composed of four descriptor words RDES0-RDES3. Each descriptor can point to up to 2 buffers for storing frame data.

The data buffer allows to store the entire or partial data of the same frame, but not more than one frame. Descriptor queues can be forward-connected through an explicit chain structure or an implicit ring structure. Set RDES1.RCH of the receive descriptor and TDES1.TCH of the transmit descriptor to 1, which can realize the explicit connection of the descriptor (the chain structure of the descriptor), and the buffer address will be stored in RDES2 and TDES2. The address where the next descriptor is stored. Set RDES1.RCH of the receive descriptor and TDES1.TCH of the transmit descriptor to 0, which can realize the implicit connection of the descriptor (the ring structure of the descriptor), and the buffer address will be stored in RDES2 and TDES2, RDES3 and TDES3. When using the buffer address pointed to by the current descriptor, the descriptor pointer will point to the next descriptor. When the chain structure is used, the descriptor pointer points to the second buffer; when the ring structure is used, the next address pointed to by the descriptor pointer is calculated as follows:

$$\text{Next descriptor address} = \text{Current descriptor address} + 16 + \text{ETH\_DMABUSMOD.DSL [4:0]} \times 4$$

If current descriptor is the last descriptor in descriptor list, TDES1.TER or RDES1.RER must be set under the ring structure to identify the current descriptor as the last descriptor in the list, and next descriptor will point to the first descriptor in descriptor list. Under chain structure, can also point to the first address in the descriptor list by setting the value of TDES3 or RDES3. Once DMA detects the end of the frame it will jump to the buffer for next frame.

Figure 25-8 Two structures of descriptor

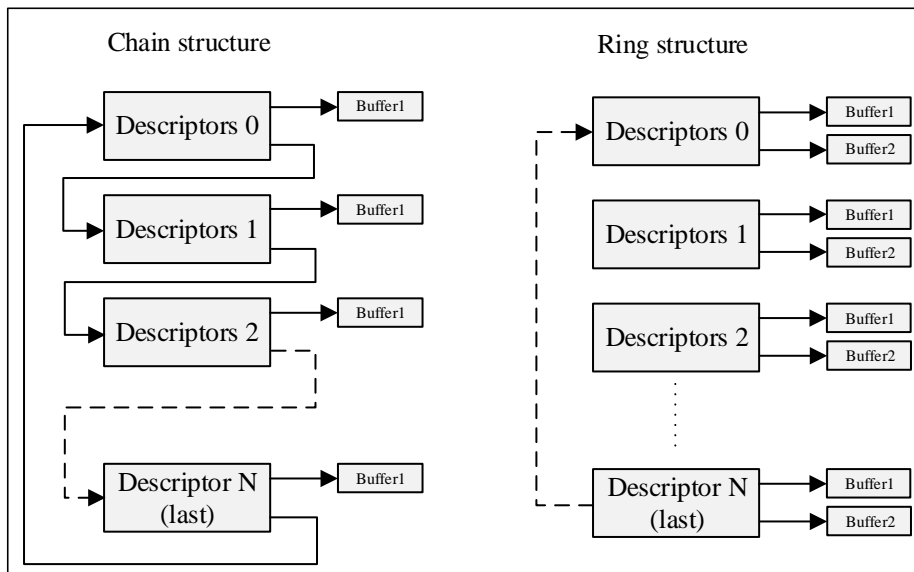

### 25.4.8.1 Data buffer address alignment

The alignment types supported by Ethernet DMA controller include byte alignment, halfword alignment, and word alignment. So the application can configure the transmit data buffer address and receive data buffer address to any address. However, when DMA initiates a transfer, the address is always accessed in a word-aligned manner. The read buffer and write buffer accesses are also different:

- **Read buffer:** If the address of transmit buffer is 0x2000 01A2, and need to transfer 15 bytes. After starting the read operation, DMA will actually read 20 bytes from addresses 0x2000 01A0, 0x2000 01A4, 0x2000 01A8, 0x2000 01AC and 0x2000 01B0, and then discard the first 2 bytes (0x2000 01A0 and 0x2000 01A1) and the last 3 bytes (0x2000 01B1, 0x2000 01B2 and 0x2000 01B3).
- **Write buffer:** If the address of receive buffer is 0x2000 0AB2, and need to transfer 16 bytes. After starting the write operation, DMA will actually write five 32-bit data from address 0x2000 0AB0 to 0x2000 0AC0. But the first 2 bytes (0x2000 0AB0 and 0x2000 0AB1) and the last 2 bytes (0x2000 0AC2 and 0x2000 0AC3) are filled with null data instead.

*Note: DMA controller will not write any data beyond the defined buffer address.*

### 25.4.8.2 Buffer effective length

In process of transmit a frame, TxDMA will transmit the bytes of effective length of buffer indicated in TDES1 to MAC controller. Data for a frame can be in multiple different buffers. If TDES0.FS read by DMA controller is 1, indicating the beginning of a new frame buffer, DMA will mark the first byte transmitted as the beginning of the frame. If TDES0.LS read by DMA controller is 1, it indicates the last part of the data of current frame. As long as the frame length is not particularly large, generally a frame will be stored in a buffer, so TDES0.FS and TDES0.LS will be set at the same time in same descriptor.

In process of receive a frame, the value of the buffer length field of the received frame must be word-aligned. For word-aligned or non-word-aligned buffer addresses, the receive operation is not the same as the transmit operation. If the receive buffer address is word-aligned, it is similar to the sending process, and the effective length of the buffer is determined by the value configured in RDES1; If the receive buffer address is not word-aligned, the effective length of the buffer shall be the value configured in RDES1 minus the lower 2 bits of the buffer address. Assuming

that the total size of the cache is 1024 bytes, the address of the buffer is 0x2000 0001, and the lower 2 bits of the address are 01b, then the effective length of the buffer is 1023 bytes, ranging from 0x2000 0001 at the beginning of the frame to 0x2000 03FF.

When an SOF is received, DMA controller will set RDES0.FS to 1, and when an EOF is received, RDES0.LS will be set to 1. If the value of the receive buffer length field is configured to be large enough to store a complete frame, RDES0.FS and RDES0.LS will be set in the same descriptor. The actual received frame length can be obtained through these bits of RDES0.FL[13:0]. Application can calculate the unused buffer space by subtracting the actual received frame length from the value of receive buffer length configuration field. RxDMA always uses a new descriptor to receive the next frame.

### 25.4.8.3 TxDMA

#### 25.4.8.3.1 Transmit frame format

IEEE 802.3 stipulates that a complete transmission frame should consist of preamble, SFD, destination address (DA), source address (SA), QTAG prefix (optional), length/type field (LT), data, PAD padding field (optional) and FCS composition. Both preamble and SFD are automatically generated by MAC, and application only needs to store the destination address, source address, length/type, data, and QTAG, padding field and FCS configured as needed. PAD and FCS can be automatically generated by configuring TDES1.DP and TDES1.DC respectively.

#### 25.4.8.3.2 Transmit frame processing

A frame can be spread across different buffers and also requires multiple descriptors. When TDES1.FS is set, it means that the buffer pointed to by current descriptor is frame header. When TDES1.LS is set, it means that the buffer pointed to by current descriptor is the end of the frame. For other descriptors of current frame (descriptors whose TDES1.LS is 0), TxDMA controller only modifies and clears its TDES0.OWN bit. After transmit the data of last buffer, DMA will write the transmit status information of the entire frame into TDES0 of the last transmit descriptor and return. The data is transferred from system memory to TxFIFO, and start transmit data, but the actual data transmission is determined by MAC according to cut-through (threshold) mode or store-and-forward mode.

#### 25.4.8.3.3 TxDMA descriptor

TxDMA descriptor structure contains four 32-bit words TDES0, TDES1, TDES2 and TDES3. If IEEE 1588 timestamp function is enabled, TDES2 and TDES3 are also used to store the lower 32 bits of timestamp and the upper 32 bits of timestamp respectively (TxDMA controller will write the timestamp into TDES2 and TDES3 after frame transmission is completed. And at the same time, set TDES0.TTSS to 1 to mark timestamp of current frame as recorded). Each bit is defined and described in detail as follows:

*Note: If a frame is described by multiple descriptors, the control bits for descriptors (except TDES1.IC) are only valid for first descriptor. Status information and time stamps (if time stamping is enabled) are only written back to last descriptor.*

Table 25-8 Transmit descriptor overview

| Register | 31  | 30           | 29 | 28 | 27 | 26 | 25 | 24 | 23 | 22 | 21 | 20                   | 19 | 18 | 17 | 16 | 15 | 14 | 13 | 12 | 11 | 10                   | 9 | 8 | 7 | 6 | 5 | 4 | 3 | 2 | 1 | 0 |
|----------|-----|--------------|----|----|----|----|----|----|----|----|----|----------------------|----|----|----|----|----|----|----|----|----|----------------------|---|---|---|---|---|---|---|---|---|---|
| TDES0    | OWN | Status bits  |    |    |    |    |    |    |    |    |    |                      |    |    |    |    |    |    |    |    |    |                      |   |   |   |   |   |   |   |   |   |   |
| TDES1    |     | Control bits |    |    |    |    |    |    |    |    |    | Buffer 2 bytes count |    |    |    |    |    |    |    |    |    | Buffer 1 bytes count |   |   |   |   |   |   |   |   |   |   |



| Bit field | Name | Description   |
|-----------|------|---|
|           |      | TDES0[11]: Carrier loss<br>TDES0[10]: No carrier<br>TDES0[9]: Late collision<br>TDES0[8]: Excessive collision<br>TDES0[2]: Excessive deferral<br>TDES0[1]: Data underflow error   |
| 14        | JT   | Jabber timeout.<br>This bit is only set when ETH_MACCFG.JD bit is reset.<br>0: No Jabber timeout occurred.<br>1: A Jabber timeout occurred at MAC sender.   |
| 13        | FF   | Frame clear.<br>When set to 1, it indicates that the data in TxFIFO has been emptied.   |
| 12        | PCE  | IP data error.<br>The sender will check the value of data length field of IPv4 or IPv6 header with the actual number of TCP, UDP and ICMP data received, and set 1 to report an error if they do not match.<br>0: No IP data error occurred.<br>1: An IP data error occurred at MAC sender.   |
| 11        | LOC  | Carrier loss.<br>When transmitting, carrier loss will probabilistically occur if CRS signal (MII_CRS) is inactive for one or more transmit clock cycles and no collision occurs. This bit is only valid in half-duplex mode.<br>0: No carrier loss occurred.<br>1: A carrier loss occurred when frame is transmitted.   |
| 10        | NC   | No carrier.<br>0: Carrier sense signal of PHY is valid.<br>1: Carrier sense signal of PHY is invalid when frame is transmitted (Carrier signal is not sensed).  |
| 9         | LC   | Late collision.<br>If a collision occurs after 64 bytes (including the preamble) have been transmitted, the situation is called a late collision.<br>0: No late collision occurred.<br>1: A late conflict has occurred.<br><i>Note: This bit has no effect if the overflow error bit (TDES0.UF) is set.</i>   |
| 8         | EC   | Excessive collision.<br>If ETH_MACCFG.DR (close retry bit) is 1, then after a collision, this bit is set to 1; if ETH_MACCFG.DR (close retry bit) is 0, then after 16 consecutive collisions, this bit is set 1. If this bit is set, the transmission of the current frame is aborted.<br>0: No excessive collision occurred.<br>1: Excessive collision occurred. |
| 7         | VF   | VLAN frame.<br>0: The transmitted frame is a normal frame.<br>1: The transmitted frame is a VLAN frame.   |

| Bit field | Name    | Description  |
|-----------|---------|--|
| 6:3       | CC[3:0] | Collision count.<br>This 4-bit value records the number of collision that occurred before frame was transmitted. These bits have no effect when TDES0.EC is 1.   |
| 2         | ED      | Excessive deferral.<br>This bit is valid when ETH_MACCFG.DC is 1. If this bit is set, the transmission of the current frame is aborted.<br>0: Excessive deferral has not occurred.<br>1: Excessive deferral caused by the delay of more than 3036 bytes.   |
| 1         | UF      | Data underflow error.<br>The data underflow error means that DMA encounters an empty buffer when transmission a frame, causing MAC to abort the transmitting of current frame because the data arrives too slowly. At this time, the transmit process enters suspended state, and ETH_DMASTS.UNF and ETH_DMASTS.TI are both set to 1.<br>0: No data underflow error occurred.<br>1: A data underflow error has occurred. |
| 0         | DB      | Deferral status bit.<br>This bit indicates whether frame delay occurs because the carrier sense signal CRS is occupied before MAC transmit the frame. This bit is only valid in half duplex mode.<br>0: No transmission delay has occurred.<br>1: MAC is delayed and the transmission is delayed.  |

#### ■ TDES1: Transmit descriptor word 1

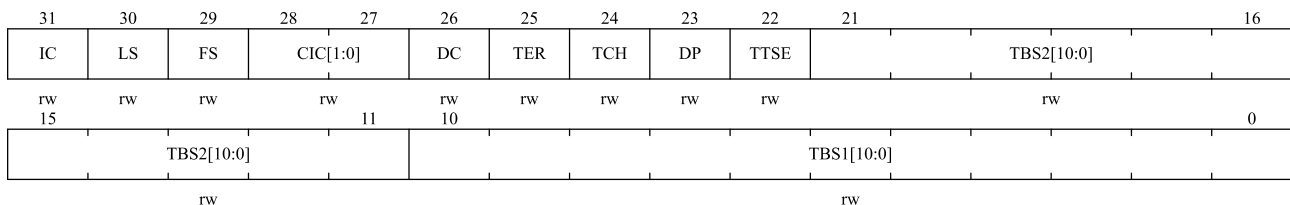

| Bit field | Name     | Description  |
|-----------|----------|--|
| 31        | IC       | Interrupt-on-completion control bit.<br>This bit is valid after TDES1.LS is set.<br>0: ETH_DMASTS.TI will not be set when frame transmission is complete.<br>1: ETH_DMASTS.TI will be set when frame transmission is complete. |
| 30        | LS       | Last block.<br>This bit indicates that buffer contains the last block of frame.<br>0: The descriptor buffer does not contain the last block of frame.<br>1: The descriptor buffer stores the last block of frame.              |
| 29        | FS       | First block.<br>This bit indicates that buffer contains the first block of frame.<br>0: The descriptor buffer does not contain the first block of frame.<br>1: The descriptor buffer stores the first block of frame.          |
| 28:27     | CIC[1:0] | Checksum insertion control bits.<br>00: Do not insert checksum.  |

| Bit field | Name       | Description   |
|-----------|------------|---|
|           |            | 01: Only enable calculation and insertion of checksum of hardware IP header.<br>10: Enable calculation and insertion of checksums of hardware IP headers and data fields, but do not calculate checksums of pseudo-headers.<br>11: Enable calculation and insertion of checksum of hardware IP header and data field, and also calculate checksum of pseudo-header. |
| 26        | DC         | Disable CRC.<br>This bit is only valid when TDES1.FS is 1.<br>0: MAC automatically insert CRC field.<br>1: MAC does not insert CRC field.   |
| 25        | TER        | Ring transmit end mode bit.<br>This bit is only used in ring structures and has higher priority than the TDES1.TCH bit.<br>0: Current descriptor is not the last of descriptor queue.<br>1: Current descriptor reaches the last of descriptor queue, and DMA returns base address of list.  |
| 24        | TCH        | Second address linked list mode bit.<br>This bit is used in a chain structure. When this bit is 1, the value of these bits in TDES1.TBS2[10:0] is invalid.<br>0: Second address in descriptor is the address of second buffer.<br>1: Second address in descriptor is the address of next descriptor.  |
| 23        | DP         | Disable PAD.<br>This bit is only valid when TDES1.FS is 1.<br>0: MAC automatically adds padding bytes to frames whose frame length is less than 64 bytes, and inserts CRC value, ignoring TDES1.DC.<br>1: MAC does not automatically pad bytes for frames whose frame length is less than 64 bytes.   |
| 22        | TTSE       | Transmit timestamp enable bit.<br>This bit is only valid when TDES1.FS is 1. When this bit is 1 and ETH_PTPTCTRL.TSENA is 1, transmit frame timestamp function is enabled.<br>0: Disable transmit frame timestamp function.<br>1: Enable transmit frame timestamp function.   |
| 21:11     | TBS2[10:0] | Transmit buffer 2 size.<br>These bits give the size (in bytes) of second data buffer and are invalid if TDES1.TCH is 1.   |
| 10:0      | TBS1[10:0] | Transmit buffer 1 size.<br>These bits give the size (in bytes) of first data buffer, if its value is 0, DMA skips this buffer and according to TDES1.TCH uses buffer 2 (TDES1.TCH = 0) or next descriptor (TDES1.TCH = 1).  |

## ■ TDES2: Transmit descriptor word 2

Before transmit a frame, application must configure TDES2 as the address of transmit buffer 1. After data is transmitted, DMA can use them to store the lower 32 bits of the frame's timestamp.

When the value of TDES2 represents the physical address of buffer 1, there is no restriction on the address alignment

of the cache. When the value of these bits represents the lower 32 bits of the timestamp, TDES1.TTSE and TDES1.LS of the current descriptor must be set.

#### ■ TDES3: Transmit descriptor word 3

Before transmit a frame, application must configure TDES3 as the address of transmit buffer 2, or as the address of next descriptor (depending on whether the descriptor type is chain or ring). After data is transmitted, DMA can use them to store the upper 32 bits of the frame's timestamp.

When the value of TDES3 represents the physical address of buffer 2 (TDES1.TCH = 0), there is no restriction on the address alignment of the buffer. When the value of TDES3 represents next descriptor address (TDES1.TCH = 1), these bits must be word-aligned. When the value of TDES3 represents the upper 32 bits of timestamp, TDES1.TTSE and TDES1.LS of the current descriptor must be set.

#### 25.4.8.3.4 Processing after sending query suspension

After the transmission is started, DMA will continuously query transmit descriptor. DMA will enter the suspended state and suspend the transmission in the following cases. The current descriptor is fixed to the last descriptor before suspension.

- When DMA detects that TDES0.OWN is 0, that is, CPU occupies the descriptor, DMA will enter suspended state and suspend the query. At this time, ETH\_DMASTS.NIS and ETH\_DMASTS.TU will be set to 1. In this case, it is necessary to set TDES0.OWN to 1 to transfer the ownership of descriptor to DMA, and then initiate a send query command to try to re-acquire descriptor.
- In process of transmit a frame, if a data underflow error is detected, frame transmission will be suspended and enter suspended state. TDES0.ES and TDES0.UF will be set, as will ETH\_DMASTS.AIS and ETH\_DMASTS.UNF. In this case, it is still necessary to initiate a transmit query command to try to re-obtain descriptor.

#### 25.4.8.3.5 TxDMA operation flow

DMA operation of the sender is divided into two cases: non-OSF mode and OSF mode. By default, non-OSF mode is operated. The specific description and operation flow are as follows::

##### ■ Non-OSF mode

The operation flow of TxDMA in default mode is as follows:

1. Initialize frame data to transmit buffer, configure transmit descriptor (TDES0~TDES3), and set TDES0.OWN to 1;
2. Set ETH\_DMAOPMOD.ST to 1 to enable TxDMA controller;
3. Start TxDMA controller to poll transmit descriptor list for frames to be transmitted. If TxDMA detects that an error has occurred, or TDES0.OWN is 0, controller will terminate transfer and enter suspension state and set ETH\_DMASTS.TU (transmit buffer unavailable) and ETH\_DMASTS.NIS (normal interrupt summary) to 1, and then skip to step 8;
4. If TDES0.OWN bit is set to 1, that is, fetched descriptor is occupied by DMA, then DMA parses the configured transmit frame and transmit data buffer address from descriptor;
5. DMA fetches data from memory, and then dumps it to TxFIFO;
6. TxDMA controller will keep polling descriptor list until TDES1.LS is set to 1 after the end of frame has been

transmitted. If TDES1.LS of current descriptor is 0, after all buffered data is transmitted to TxFIFO, clear TDES0.OWN to close this descriptor. TxDMA controller will wait to write back the descriptor status and the IEEE 1588 timestamp value (provided that timestamp function is enabled);

7. After completing a complete frame transmission, ETH\_DMASTS.TI (transmit status bit) will be set only when TDES1.IC is 1. If DMA interrupt is enabled, corresponding interrupt will be entered. Then DMA controller returns to step 3 to continue processing next frame;
8. In suspended state, if any write operation is performed to ETH\_DMATXPD register, TxDMA will return to running state, try to re-acquire descriptor, and return to step 3, and transmit underflow flag will be cleared.

#### ■ OSF mode

Set ETH\_DMAOPMOD.OSF to 1 to enter Operation Second Frame (OSF) mode. In this mode, TxDMA can transmit next frame before status information of the previous frame is written back. OSF mode can improve the transmission efficiency when system clock frequency is much higher than MAC frequency (10Mbps or 100Mbps). After DMA has transmitted the previous frame of data, it can immediately query the transmit descriptor of second frame without waiting for the status of the frame to be written back. If both TDES0.OWN and TDES1.FS are set to 1, TxDMA will immediately read the second frame data and store it in TxFIFO.

The operation flow of TxDMA in OSF mode is as follows:

1. Follow steps 1~6 of TxDMA default mode;
2. DMA directly fetches the next descriptor without waiting until last descriptor of previous frame is closed (TDES1.LS is 1);
3. If TDES0.OWN is 1, that is, fetched descriptor is occupied by DMA, the data of next frame is read from the parsed transmit buffer address; if TDES0.OWN is 0, fetched descriptor is not occupied by DMA, TxDMA enters suspended state and skips to step 7;
4. TxDMA controller will poll descriptor list until the end of frame is transmitted. If a frame is described by multiple descriptors, the intermediate descriptors are closed after acquisition;
5. TxDMA waits for transmit status information and timestamp of the previous frame (provided that timestamp is enabled). After receive status information, TDES0.OWN is cleared, indicating that ownership of descriptor is handed over to CPU, and at the same time the relevant status information will be written to corresponding bit of TDES0 by DMA;
6. After transmit a complete frame, ETH\_DMASTS.TI will be set only when TDES1.IC is 1. If DMA interrupt is enabled, corresponding interrupt will be entered. If status information returned by previous frame is normal, skip to step 3; if it indicates that there is a data underflow error, TxDMA enters suspended state and skips to step 7;
7. If the pending status information and timestamp of a transmit frame are received in suspended state (provided that timestamp is enabled), TxDMA will write this information into transmit descriptor and corresponding TDES0.OWN cleared, then set relevant interrupt flag and return to suspend state;
8. In suspended state, if any write operation is performed to register ETH\_DMATXPD, TxDMA will return to running state and try to re-acquire descriptor, and transmit underflow flag will be cleared. If there is pending status information, skip to step 1 again; otherwise, skip to step 2 again.

## 25.4.8.4 RxDMA

### 25.4.8.4.1 Receive frame processing

When MAC receives the frame data, address filtering module also starts to work. If the frame does not pass address filtering, MAC Rx FIFO will discard frame and will not forward it to receiving buffer through RxDMA. Conversely, if working in cut-through (threshold) mode and the received frame length is greater than or equal to the preset receive threshold, or working in store-and-forward mode and a complete frame is stored in the Rx FIFO, it will be forwarded to the receive buffer. In the process of receiving a frame, if the data in Rx FIFO is less than 64 bytes, the receiving process collides, or the receiving frame is terminated in advance, the data in Rx FIFO will be lost and will not be forwarded.

When the forwarding conditions are met, RxDMA controller starts to transfer data from Rx FIFO to the receive buffer. If the current buffer contains SOF, RDES0.FS will be set when RxDMA controller writes back the frame receiving state, indicating that the first part of the frame is stored in this descriptor. If the current buffer contains EOF, RDES0.LS is set when RxDMA controller writes back the frame received state to indicate that this descriptor stores the last part of the frame. Usually when the receive buffer size is larger than the length of the received frame, RDES0.FS and RDES0.LS will be set in the same descriptor. When the buffer receives EOF, or the buffer of the current descriptor is not enough to store the entire frame, RxDMA will get the next receive descriptor and clear the RDES0.OWN of the previous descriptor to close the previous descriptor. When RDES1.DIC = 0 and RDES0.LS is set, other states of the descriptor will also be updated and ETH\_DMASTS.RI will be set; when RDES1.DIC = 1, ETH\_DMASTS.RI will not be set. When a new frame is received, if RDES0.OWN of the descriptor is 1, the above RxDMA controller operation is repeated. If the descriptor's RDES0.OWN is 0, DMA controller enters the pending state and sets ETH\_DMASTS.RU to 1. Record the current value of the descriptor list address pointer and use it as the starting address of the descriptor after exiting the pending state.

### 25.4.8.4.2 RxDMA descriptor

RxDMA descriptor structure contains four 32-bit words, RDES0, RDES1, RDES2, and RDES3. If IEEE 1588 timestamp function is enabled, RDES2 and RDES3 are also used to store the lower 32 bits of the timestamp and the upper 32 bits of timestamp, respectively (MAC controller will complete the reception of the timestamped frame and before DMA closes descriptor (RDES0.OWN is cleared to 0), and the timestamp is written to RDES2 and RDES3). Each bit is defined and described in detail as follows:

Table 25-9 Receive descriptor overview

| Register | 31  | 30           | 29          | 28 | 27 | 26 | 25 | 24 | 23 | 22                   | 21 | 20 | 19 | 18 | 17 | 16 | 15 | 14                   | 13 | 12 | 11 | 10 | 9 | 8 | 7 | 6 | 5 | 4 | 3 | 2 | 1 | 0 |
|----------|---|--------------|-------------|----|----|----|----|----|----|----------------------|----|----|----|----|----|----|----|----------------------|----|----|----|----|---|---|---|---|---|---|---|---|---|---|
| RDES0    | OWN   | AFM          | Status bits |    |    |    |    |    |    |                      |    |    |    |    |    |    |    |                      |    |    |    |    |   |   |   |   |   |   |   |   |   |   |
| RDES1    | DIC   | Control bits |             |    |    |    |    |    |    | Buffer 2 bytes count |    |    |    |    |    |    |    | Buffer 1 bytes count |    |    |    |    |   |   |   |   |   |   |   |   |   |   |
| RDES2    | Buffer 1 address/Timestamp low                          |              |             |    |    |    |    |    |    |                      |    |    |    |    |    |    |    |                      |    |    |    |    |   |   |   |   |   |   |   |   |   |   |
| RDES3    | Buffer 2 address/Next descriptor address/Timestamp high |              |             |    |    |    |    |    |    |                      |    |    |    |    |    |    |    |                      |    |    |    |    |   |   |   |   |   |   |   |   |   |   |

#### ■ RDES0: Receive descriptor word 0

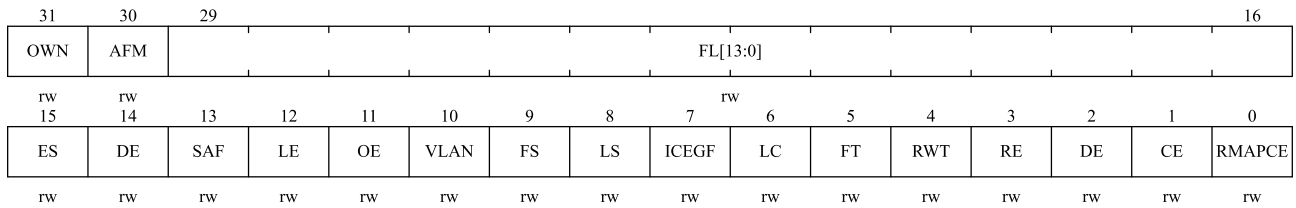

| Bit field | Name     | Description   |
|-----------|----------|---|
| 31        | OWN      | Occupancy bit.<br>0: Indicates that CPU occupies descriptor.<br>1: Indicates that DMA occupies descriptor.<br>DMA clears this bit to 0 after transferring a complete frame or filling the buffer corresponding to descriptor.   |
| 30        | AFM      | Failed destination address filter.<br>0: The received frame passes destination address filter.<br>1: The received frame does not pass destination address filter.   |
| 29:16     | FL[13:0] | Frame length.<br>These bits indicate the byte length of the received frame transferred to the input buffer. This bit is only valid when RESD0.LS is 1 and RDES0.DE is 0. If both RESD0.LS and RESD0.ES are 0, these bits indicate the cumulative number of bytes that the current received frame has transferred to the memory. |
| 15        | ES       | Error summary.<br>This bit is only valid when RESD0.LS is 1.<br>This bit is the logical OR of:<br>RDES0[14]: Descriptor error<br>RDES0[11]: Overflow error<br>RDES0[7]: IP header error<br>RDES0[6]: Late collision<br>RDES0[4]: Watchdog timeout<br>RDES0[3]: Receive error<br>RDES0[1]: CRC error                             |
| 14        | DE       | Descriptor error.<br>This bit is only valid when RESD0.LS is 1.<br>When the buffer size of current descriptor is smaller than the frame length of received frame and DMA cannot occupy the next descriptor, a descriptor error will occur.<br>0: No descriptor error occurred.<br>1: A descriptor error has occurred.           |
| 13        | SAF      | Failed source address filter.<br>0: No fail source address filter event occurred.<br>1: The received frame did not pass source address filter.  |
| 12        | LE       | Length error.<br>This bit is only valid when RDES0.FT is 0, which indicates that the value of the received Ethernet frame header length/type field does not match the actual length of the received frame.  |

| Bit field | Name  | Description  |
|-----------|-------|--|
|           |       | 0: No length error occurred.<br>1: A length error has occurred.  |
| 11        | OE    | Overflow error.<br>This bit is set when RxFIFO has overflowed and part of the received frame has been transferred to input buffer.<br>0: No overflow error occurred.<br>1: RxFIFO overflow occurred and frame data is invalid.   |
| 10        | VLAN  | VLAN frame.<br>0: Received frame is a non-VLAN frame.<br>1: Currently received frame is a VLAN frame.  |
| 9         | FS    | First descriptor.<br>This bit indicates that the current descriptor holds the first part of received frame.<br>0: The current descriptor does not hold the first part of frame.<br>1: The current descriptor holds the first part of frame.  |
| 8         | LS    | Last descriptor.<br>This bit indicates that the current descriptor holds the last part of received frame.<br>0: The current descriptor does not hold the last part of frame.<br>1: The current descriptor holds the last part of frame.  |
| 7         | ICEGF | IP frame header checksum error.<br>0: No IPv header checksum error occurred.<br>1: An IPv4 or IPv6 header error has occurred. Errors may be due to mismatched values in EtherType and IP Version fields, an incorrect IPv4 header checksum, or insufficient IP header bytes for Ethernet frame.  |
| 6         | LC    | Late collision.<br>A late collision indicates that a collision occurred after 64 bytes of data were received. This bit is only valid in half-duplex mode.<br>0: No late collision occurred.<br>1: A late collision occurred in the process of receiving frame.   |
| 5         | FT    | Frame type.<br>0: Received frame is an IEEE802.3 frame.<br>1: Received frame is an Ethernet type frame (the value of Ethernet frame header length/type field is greater than or equal to 0x0600, when the received frame is too short (the frame length is less than 14 bytes), this bit is invalid).  |
| 4         | RWT   | Receive watchdog timeout.<br>When ETH_MACCFG.WD = 0, this bit indicates that more than 2048 bytes of frame data have been received; when ETH_MACCFG.WD = 1, this bit indicates that more than 16384 bytes of frame data have been received.<br>0: No receive watchdog timeout occurred.<br>1: A watchdog timeout occurred while receiving a frame, and current received frame will be truncated. |
| 3         | RE    | Receive error.<br>This bit indicates that the valid interface signal Rx_ER is received when the Rx_DV signal is valid during the frame receiving process.  |

| Bit field | Name   | Description  |
|-----------|--------|--|
|           |        | 0: No reception error occurred.<br>1: A reception error has occurred.  |
| 2         | DE     | Dribble bit error.<br>This bit is only valid in MII mode, indicating that the received frame length is not an integer multiple of bytes.<br>0: No Dribble bit error occurred.<br>1: A Dribble bit error has occurred.  |
| 1         | CE     | CRC error.<br>This bit is only valid when RDES0.LS is 1, indicating that the FCS of the received frame does not match the hardware calculation result.<br>0: No CRC error occurred.<br>1: A CRC error has been detected in received frame.   |
| 0         | RMAPCE | Data checksum error.<br>0: No data checksum error occurred.<br>1: TCP, UDP or ICMP checksum calculated by hardware does not match the value of TCP, UDP or ICMP checksum field of received frame.<br>This bit is also set to 1 when the data length of received Ethernet frame does not match the value of IPv4 or IPv6 packet length field. |

### ■ RDES1: Receive descriptor word 1

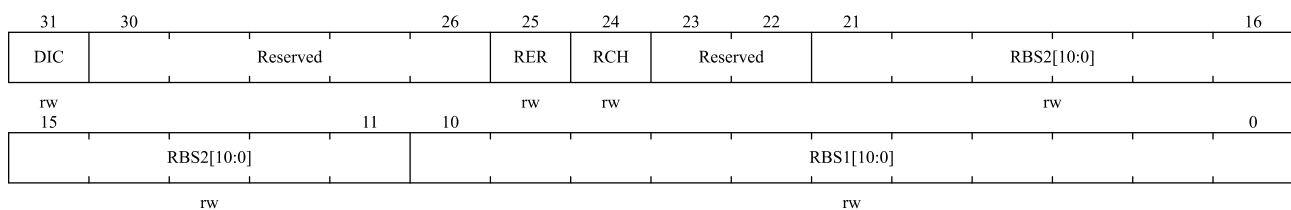

| Bit field | Name     | Description  |
|-----------|----------|--|
| 31        | DIC      | Turn off receive completion interrupt.<br>0: ETH_DMASTS.RI will be set to 1 immediately after receive is completed. At this time, if the corresponding interrupt is enabled, an interrupt will be triggered.<br>1: ETH_DMASTS.RI will not be set to 1 after receive is completed, and the corresponding interrupt will not be triggered. |
| 30:26     | Reserved | Reserved, the reset value must be maintained.  |
| 25        | RER      | End of receive descriptor ring structure.<br>This bit indicates that the last descriptor in descriptor list is reached, and next descriptor automatically returns the base address of the list.<br>0: Current descriptor is not the last descriptor.<br>1: Reach the last descriptor of the descriptor list.                             |
| 24        | RCH      | Second address list.<br>This bit is only used in chain structure. When this bit is 1, these bit values of RDES1.RBS2[10:0] are ignored.<br>0: Second address in descriptor points to the address of second buffer.<br>1: Second address in descriptor is the address of next descriptor.   |

| Bit field | Name       | Description   |
|-----------|------------|---|
|           |            | <i>Note: When RER=1, even if this bit is set, the next descriptor will return the list base address.</i>  |
| 23:22     | Reserved   | Reserved, the reset value must be maintained.   |
| 21:11     | RBS2[10:0] | Receive buffer 2 size.<br>These bits indicate the size of receive buffer 2 in bytes. The buffer size must be set to a multiple of 4. These bits are ignored when RDES1.RCH is 1.  |
| 10:0      | RBS1[10:0] | Receive buffer 1 size.<br>These bits indicate the size of receive buffer 1 in bytes. The buffer size must be set to a multiple of 4. If these bits are 0, DMA ignores the buffer and uses buffer 2 (RDES1.RCH = 0) or next descriptor (RDES1.RCH = 1) depending on RDES1.RCH. |

#### ■ RDES2: Receive descriptor word 2

RDES2 has 2 functions: the address pointer of buffer 1 and the lower 32 bits of the timestamp. Configured as the address of buffer 1 before DMA controller acquires this descriptor. If RDES1.RBS1 is not 0, the address in RDES2 is used to store the received data frame. There is no restriction on the address alignment of the cache. When timestamp function is enabled and RDES0.LS is 1, if the received frame passes the address filtering and corresponding frame type enable bit is set, DMA will write the lower 32 bits of the timestamp into RDES2. If corresponding frame type enable bit is not set in received frame, RDES2 will keep the value of the original address.

#### ■ RDES3: Receive descriptor word 3

RDES3 has 2 functions: when data is received, the address of buffer 2 or the address of next descriptor and the high 32-bit timestamp are stored. Before DMA controller obtains the descriptor, if RDES1.RCH = 0, configure RDES3 as the address of buffer 2. At this time, if RDES1.RBS1 is not 0, use the address of RDES3 to store the received data frame; if RDES1.RCH = 1, then configure RDES3 as the next descriptor address, and the address needs to be word-aligned. If RDES1.RER is not 0, then RDES3 is ignored.

When timestamp function is enabled and RDES0.LS is 1, if the received frame passes the address filtering and the corresponding frame type enable bit is set, DMA will write the high 32 bits of the timestamp to RDES3. If the corresponding frame type enable bit is not set in the received frame, RDES3 will keep the value of the original address.

#### 25.4.8.4.3 Processing when a new frame is received in suspended state

In suspended state, when a new frame is received and the forwarding conditions are met, RxDMA will obtain the frame descriptor. If RDES0.OWN is 1, RxDMA controller exits the suspend state and resumes the running state to start receiving frames. But when RDES0.OWN is 0, application can choose whether to clear the frame in Rx FIFO by configuring ETH\_DMAOPMOD.DFF. If ETH\_DMAOPMOD.DFF = 0, RxDMA controller will drop the current frame at the top of Rx FIFO and increment ETH\_DMAMFBOCNT.MISFRMCNT (missed frame count) by 1 (repeat the process if there is more than one frame in Rx FIFO). If ETH\_DMAOPMOD.DFF = 1, the frame at the top of Rx FIFO will not be dropped. When RDES0.OWN is 0, ETH\_DMASTS.RU bit will be set and RxDMA controller is still suspended.

#### 25.4.8.4.4 Get receive descriptor

DMA will attempt to acquire a receive descriptor whenever any of the following conditions are met:

- ETH\_DMAOPMOD.SR changes from 0 to 1, when DMA controller enters the running state

- Before EOF is received, the buffer of current descriptor is full, and the entire buffer of current descriptor is not large enough to receive the entire frame
- A complete frame is received and forwarded to receive buffer, but current descriptor has not been closed
- A new frame is received when DMA is suspended without occupying the descriptor
- Perform any write operation to ETH\_DMARXPD register

#### 25.4.8.4.5 RxDMA operation flow

The operation flow of RxDMA is as follows:

1. Initialize DMA receive descriptor and set RDES0.OWN to 1;
2. Set ETH\_DMAOPMOD.SR bit to 1 to enable RxDMA controller. After DMA enters running state, receive descriptor is obtained from the base address of the descriptor list configured by ETH\_DMARXDLADDR register. If RDES0.OWN is 1, the current descriptor starts to receive frames; if RDES0.OWN is 0, DMA enters suspended state and skips to step 9;
3. If the obtained descriptor shows that the descriptor is occupied DMA (RDES0.OWN = 1), then the control bit and cache address of the descriptor will be parsed and recorded by DMA;
4. Process the received frame and transfer the data from Rx FIFO to receive buffer;
5. If frame transfer is complete or buffer is full, receiving controller will get next receive descriptor from descriptor queue;
6. If current frame transfer ends, DMA operation skips to step 7. If current frame transmission does not end (end of frame EOF is not received), two things can happen:
  - a) If RDES0.OWN of next descriptor is 0 and receive frame clearing function is not enabled, RxDMA controller sets RDES0.DE (descriptor error bit). RxDMA controller clears RDES0.OWN of the current descriptor to close the descriptor, if frame clearing function is not enabled, sets RDES0.LS, otherwise does not set RDES0.LS, and then skips to step 8.
  - b) If RDES0.OWN of next descriptor is 1, RxDMA clears RDES0.OWN to close current descriptor, and then returns to step 4.
7. If IEEE 1588 timestamp function is enabled, and received frame meets the conditions of the frame that needs to record the timestamp, DMA controller will write the low and high bits of the acquired timestamp into RDES2 and RDES3 of current descriptor after receiving the frame. At the same time, DMA writes the received status information returned from MAC into RDES0, clears RDES0.OWN to 0, and sets RDES0.LS to 1;
8. If RDES0.OWN of newly acquired descriptor is 1, RxDMA controller operates jumping step 4; if RDES0.OWN is 0, received frame will be cleared first (provided that the receive frame clearing function is enabled), and then RxDMA controller enters suspend state and sets ETH\_DMASTS.RU (receive buffer unavailable) to 1;
9. When any write operation is performed to ETH\_DMARXPD register or Rx FIFO receives the next frame of data, the suspend state can be exited. When DMA exits suspended state, DMA operation jumps to step 2 and attempts to re-acquire next descriptor.

#### 25.4.8.5 MAC initialization using DMA

The MAC initialization process using DMA controller is as follows:

1. Set ETH\_DMABUSMOD register bus access related parameters.
2. Set ETH\_DMAINTEN register to mask unnecessary interrupt sources.
3. First write the base address of the transmit descriptor list into ETH\_DMATXDLADDR register, and then write the base address of the receive descriptor list into ETH\_DMARXDLADDR register.
4. Configure the relevant filter registers as required.
5. Set the values of ETH\_MACCFG.FES and ETH\_MACCFG.DM according to the register result read from the external PHY, and select half-duplex or full-duplex communication mode and the communication speed of 10Mbps or 100Mbps. Set ETH\_MACCFG.TE and ETH\_MACCFG.RE to 1 to enable the transmit engine and receive engine of MAC.
6. Set ETH\_DMAOPMOD.ST and ETH\_DMAOPMOD.SR to 1 to enable TxDMA and RxDMA.

*Note: If the HCLK frequency configuration is too low, RxFIFO may overflow at startup. It is recommended to enable RxDMA first, and then set ETH\_MACCFG.RE to 1.*

#### **25.4.8.6 Arbiter for TxDMA and RxDMA**

DMA arbiter can improve the efficiency of DMA controller through fixed and polling priority arbitration methods. When ETH\_DMABUSMOD.DA is set to 0, the polling priority arbitration method is adopted. If TxDMA and RxDMA request to access the data bus at the same time, the access priority between TxDMA and RxDMA can be configured by setting these bits of ETH\_DMABUSMOD.PR[1:0] level ratio. When ETH\_DMABUSMOD.DA is set to 1, a fixed priority is selected. If TxDMA and RxDMA request to access the data bus at the same time, in this arbitration mode, RxDMA has a higher access priority to the bus.

#### **25.4.8.7 Error response to DMA**

If DMA has a wrong bus response during the transfer, DMA controller will treat it as a fatal error, stop all operations immediately, and update the status register ETH\_DMASTS. Once this happens, Ethernet peripheral must be reset and DMA reinitialized before DMA can resume normal operation.

### **25.4.9 Precision time protocol (PTP)**

MAC's Precision Time Protocol (PTP) module mainly supports recording the exact time when PTP packets are sent and received from the Ethernet port, and returns it to the application. Much of the protocol is implemented by application software on top of the UDP layer.

For details on Precision Time Protocol (PTP), please refer to the IEEE 1588™ related documentation.

#### **25.4.9.1 Reference clock source**

In IEEE 1588 protocol standard, the upper 32 bits of the 64-bit system reference time are second-level time information, and the lower 32 bits are nanosecond-level time information.

PTP reference clock input is used to generate the system reference time (referred to as the system time) and obtain the timestamp value of PTP frame. PTP reference clock frequency cannot be less than the resolution of the timestamp counter, and the time synchronization accuracy between the master node and the slave node is about 0.1us.

#### **25.4.9.2 Synchronization accuracy**

The accuracy of time synchronization depends on the frequency of PTP reference clock input and the frequency drift

characteristics of the crystal oscillator used, as well as how often the synchronization process is performed.

### 25.4.9.3 System time calibration method

The 64-bit PTP system time is used as the basis for recording send/receive timestamps, and is updated by PTP input reference clock. In order to correct the frequency offset, PTP system time needs to be calibrated, and the initialization and calibration support two modes of coarse adjustment and fine adjustment.

Rough Adjustment Calibration Perform system time initialization and calibration by configuring the PTP timestamp update registers (ETH\_PTPSECUP and ETH\_PTPNSUP). If ETH\_PTPTSCTRL.TSINIT is set, the PTP timestamp update register is used for initialization; if ETH\_PTPTSCTRL.TSUPDT is set, the system time plus or minus the value of PTP timestamp update register is used to adjust the system time.

Fine-tuning calibration is to add the value in the addend register ETH\_PTPTSADD to the accumulator every HCLK cycle. A pulse is generated when the accumulator overflows, causing the value of the timestamp low register ETH\_PTPSS to increment according to the value of the subsecond increment register ETH\_PTPSSINC. This process needs to wait for a period of time to complete, to ensure that the slave clock can be linearly synchronized with the master clock to avoid large jitter.

The following diagram illustrates the flow of the fine-tuning algorithm:

Figure 25-9 System time precision calibration

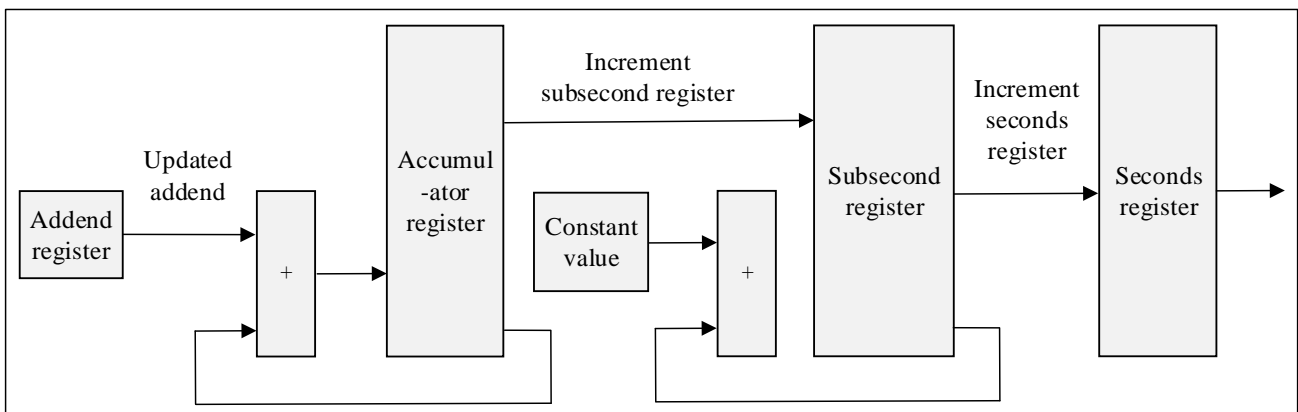

The following example illustrates the configuration method of updating system time in fine adjustment mode:

Set the initial value of the addend register (Clock\_Addend\_Value(0)) to the slave clock, the initial value is calculated in the following way: The accuracy of the system clock update circuit needs to reach 20ns (the update frequency is 50MHz). When the reference clock HCLK is 70MHz, the frequency ratio is  $70/50 = 1.4$ , the addend that should be written into the ETH\_PTPTSADD register is  $2^{32}/1.4 = 0xB6DB\ 6DB6$ ; when the frequency drift of the reference clock is reduced to 60MHz, the frequency ratio becomes  $60/50 = 1.2$ , and the addend written to the addend register is the value should be  $2^{32}/1.2 = 0xD555\ 5555$ ; when the base clock frequency drift increases to 80MHz, the frequency ratio becomes  $80/50 = 1.6$ , and the value written to the addend register should be  $2^{32}/1.6 = 0xA000\ 0000$ . After configuring the up-counter, it is necessary to configure the sub-second increment register to ensure the accuracy of 20ns. The value of the subsecond increment register updates the timestamp low register each time the accumulation register overflows. Since bits 0 to 30 of the timestamp low register represent the sub-second value of the system time, the precision is equal to  $10^9\text{ns}/2^{31} = 0.46\text{ns}$ . In order to achieve a system time accuracy of 20ns, the value of the sub-second increment register should be set to  $20/0.46 = 43$ .

Assuming that the delay Master\_to\_Slave\_Delay transmitted between the master and slave devices is a fixed value, the time when the master device sends a SYNC message to the slave device is MSYNCT(n), the local time of the

slave device is SLOCALT(n), and the local time of the master device is MLOCALT(n), the master clock count between two SYNC messages is MCLOCKC(n), the slave clock count between two SYNC messages is SCLOCKC(n), and the slave clock frequency adjustment factor is SCFAF(n), the clock addend value of the addend register is Clock\_Addend\_Value(n), then the calculation method to determine the synchronization frequency in multiple SYNC cycles is as follows, but note that multiple SYNC messages may be required to complete the synchronization of the master and slave devices according to the situation:

$$MLOCALT(n) = MSYNCT(n) + \text{Master\_to\_Slave\_Delay}(n)$$

$$MCLOCKC(n) = MLOCALT(n) - MLOCALT(n-1)$$

$$SCLOCKC(n) = SLOCALT(n) - SLOCALT(n-1)$$

$$SCFAF(n) = (MCLOCKC(n) + MCLOCKC(n) - SCLOCKC(n)) / SCLOCKC(n)$$

$$\text{Clock\_Addend\_Value}(n) = SCFAF(n) * \text{Clock\_Addend\_Value}(n-1)$$

#### 25.4.9.4 System time initialization process

Timestamp function needs to configure ETH\_PTPTSCTRL.TSENA to 1 first, and then initialize timestamp counter as follows to start timestamp operation:

1. Set ETH\_MACINTMSK.TSIM to 1 to mask timestamp trigger interrupt;
2. Set ETH\_PTPTSCTRL.TSENA to 1 to enable timestamp;
3. Set sub-second increment register to configure clock precision;
4. If choose coarse adjustment and calibration, skip directly to step 7; if choose fine adjustment and calibration, first configure timestamp adder register ETH\_PTPTSADD, and then set ETH\_PTPTSCTRL.TSADDREG to enable the update of timestamp adder register;
5. Query and wait for ETH\_PTPTSCTRL.TSADDREG to become 0;
6. Set ETH\_PTPTSCTRL.TSCFUPDT to 1, and update system timestamp with fine adjustment and calibration;
7. Set timestamp update high register and timestamp update low register to configure system time value;
8. Set ETH\_PTPTSCTRL.TSINIT to 1, initialize system time, replace original system time with the value of timestamp high and low update registers, and timestamp counter starts to work.

#### 25.4.9.5 Steps to update system time with coarse adjustment

1. Set offset value to timestamp update high register and timestamp update low register, the value can be negative;
2. Set ETH\_PTPTSCTRL.TSUPDT to 1, enable updating system time, and add the offset values of timestamp high and low update registers to the original system time;
3. Wait for ETH\_PTPTSCTRL.TSUPDT bit to be cleared.

#### 25.4.9.6 Steps to update system time with fine adjustment

1. Calculate the value of the addend register corresponding to the desired system clock frequency according to the introduction of the "System time calibration method" above;
2. Write the value to upcounter, and set ETH\_PTPTSCTRL.TSADDREG to 1, and update the value to PTP module;
3. Write the desired time into the timestamp update high register and timestamp update low register, and set ETH\_MACINTMSK.TSIM to 0 to allow timestamp interrupts;

4. Set `ETH_PTPTSCTRL.TSTRIG` to 1 to enable timestamp interrupt;
5. When timestamp interrupt occurs, read the value of `ETH_MACINTSTS` register and clear the corresponding interrupt flag bit;
6. Write the original value into the timestamp addend register, then set `ETH_PTPTSCTRL.TSADDREG` to 1, and update the value to PTP module.

#### 25.4.9.7 Transmission and receive of frames with PTP function

If IEEE 1588 (PTP) timestamp function is enabled, when MAC outputs the SFD of the transmitted frame or receives the SFD of the received frame, the 64-bit timestamp value will be recorded, and stored together with the frame's transmit/receive status information. To the corresponding transmit/receive descriptor, "TxDMA descriptor" and "RxDMA descriptor" are described in detail.

#### 25.4.9.8 PTP pulse-per-second output signal (PPS)

After ETH module is enabled, PPS output function is automatically turned on, and it is output to PB5/PB6 in different pin reset methods. The default clock cycle of the output pulse is 18M/HCLK (when the HCLK is 144M, the pulse width is 125ms). The function can check whether all nodes in the network are synchronized. Connect the PPS outputs of both the master and slave devices to an oscilloscope to test the difference between the local slave clock and the master clock.

#### 25.4.10 Typical ethernet configuration flow example

After a power-on reset or system reset, the recommended configuration and startup process for Ethernet module is as follows:

1. Configure RCC module, enable HCLK clock and Ethernet transmit/receive clock;
2. Configure `AFIO_RMP_CFG` to select MII or RMI connection mode, and map corresponding function pins to alternate functions;
3. Poll `ETH_DMABUSMOD` register until `ETH_DMABUSMOD.SWR` bit is reset after reset is completed;
4. Get and configure PHY register parameters:

According to the HCLK frequency, configure SMI clock frequency, communicate with the external PHY and access the corresponding registers, confirm whether the external PHY supports half/full duplex working mode, 10Mbps/100Mbps communication speed, etc., and configure the information of the external PHY register to the `ETH_MACCFG` register.

5. Initialize Ethernet DMA module:

Configure `ETH_DMABUSMOD`, `ETH_DMARXDLADDR`, `ETH_DMATXDLADDR`, `ETH_DMAOPMOD` registers to initialize DMA module for data transfer.

6. Initialize physical memory space for storing descriptor list and data cache:

Based on the addresses in `ETH_DMARXDLADDR` and `ETH_DMATXDLADDR` registers, DMA is initialized to hold transmit and receive descriptors (`TDES0.OWN = 0` or `RDES0.OWN = 1`) and data buffers.

7. Enable the MAC and DMA modules to start data transfer:

Start MAC transmitter and receiver by setting `ETH_MACCFG.TE` and `ETH_MACCFG.RE` to 1, and enable

DMA transmission and reception by setting ETH\_DMAOPMOD.ST and ETH\_DMAOPMOD.SR to 1.

8. When transmit frame data:
  - a) Select one or more transmit descriptors, write the transmit frame data to the buffer address specified in the transmit descriptor, and set TDES0.OWN in transmit descriptor to make DMA occupy descriptor;
  - b) Write any value into ETH\_DMATXPD register to make TxDMA exit the suspend mode and start sending data;
  - c) It is possible to confirm whether the transmission of current frame is completed by polling TDES0.OWN of current descriptor until it is reset or polling ETH\_DMASTS.TI until it is set (only applicable when TDES1.IC is 1).
9. When receive frame data:
  - a) View first receive descriptor in descriptor list (the address of descriptor can be obtained through the ETH\_DMARXDLADDR register);
  - b) Query RDES0.OWN, if it is reset, it means that descriptor has been used, and receive buffer has stored received frame;
  - c) Process received frame data in buffer;
  - d) Set RDES0.OWN of current descriptor to receive a new frame by alternate current descriptor;
  - e) To view next descriptor in list, skip to step b.

### 25.4.11 Ethernet interrupt

Ethernet module has 2 interrupt vectors for Ethernet wake-up events (detecting remote wake-up frames or Magic Packet wake-up frames) mapped to EXTI line 19 and Ethernet normal operation.

The interrupt vector mapped to the Ethernet wake-up event is used for the interrupt generated by PMT module during the wake-up event. The wake-up event is a remote wake-up frame reception event or a Magic Packet wake-up frame reception event. The wake-up event is mapped to EXTI line 19, and if the rising edge interrupt on EXTI line 19 is enabled, the wake-up event can cause MCU to exit low-power mode. If PMT interrupt is also enabled, both the EXTI line 19 interrupt and the Ethernet interrupt are triggered.

*Note: Since PMT register is located in Rx\_CLK domain, there may be a delay caused by the difference between the HCLK and Rx\_CLK clock frequencies from the time the application reads PMT register until these flags are cleared. To avoid entering the same interrupt twice, it is strongly recommended that the application program Wait for ETH\_MACPMTCTRLSTS.RWKPRCVD and ETH\_MACPMTCTRLSTS.MGKPRCVD to become 0 in the interrupt, and then exit the interrupt service routine.*

Interrupt vectors mapped to normal Ethernet operation are used for interrupts generated by MAC and Ethernet DMA, as described below.

#### 25.4.11.1.1 MAC interrupts

MAC controller has multiple interrupt trigger sources. ETH\_MACINTSTS register describes all types of MAC interrupts that can be generated, and each bit has its own interrupt mask bit to prevent an event from triggering an interrupt. As long as one of MAC interrupts occurs, MAC interrupt signal will be generated.

### 25.4.11.1.2 Ethernet DMA interrupts

DMA controller has two types of interrupt events, normal and abnormal, and has a corresponding interrupt enable bit to control whether an interrupt is generated. When the interrupt enable bit is cleared, or all interrupt events are cleared, the corresponding interrupt summary bit is also cleared. When both normal class and exception class interrupts are cleared, DMA interrupts are also cleared.

## 25.5 ETH register

The registers of this peripheral can be accessed in the form of bytes (8 bits), halfwords (16 bits) and words (32 bits).

### 25.5.1 ETH register overview

Table 25-10 ETH register overview

| Offset | Register          | 31          | 30       | 29 | 28 | 27 | 26 | 25 | 24 | 23 | 22 | 21       | 20 | 19       | 18 | 17 | 16       | 15        | 14 | 13   | 12       | 11   | 10        | 9        | 8        | 7        | 6        | 5        | 4        | 3        | 2        | 1        | 0      |     |          |   |   |   |   |   |   |   |   |   |   |   |
|--------|-------------------|-------------|----------|----|----|----|----|----|----|----|----|----------|----|----------|----|----|----------|-----------|----|------|----------|------|-----------|----------|----------|----------|----------|----------|----------|----------|----------|----------|--------|-----|----------|---|---|---|---|---|---|---|---|---|---|---|
| 000h   | ETH_MACCFG        | Reserved    |          |    |    |    |    |    |    |    |    | WD       | JD | Reserved |    |    | IFG[2:0] |           |    | DCRS | Reserved | FES  | DO        | LM       | DM       | IPC      | DR       | Reserved | ACS      | BL[1:0]  |          | DC       | TE     | RE  | Reserved |   |   |   |   |   |   |   |   |   |   |   |
|        | Reset Value       | 0           |          |    |    |    |    |    |    |    |    | 0        | 0  | 0        |    |    | 0        | 0         | 0  | 0    | 0        | 0    | 0         | 0        | 0        | 0        | 0        | 0        | 0        | 0        | 0        | 0        | 0      | 0   | 0        |   |   |   |   |   |   |   |   |   |   |   |
| 004h   | ETH_MACFFLT       | RA          | Reserved |    |    |    |    |    |    |    |    |          |    |          |    |    |          |           |    |      |          |      | HPF       |          | SAF      | SAIF     | PCT[1:0] |          | DBF      | PAM      | DAIF     | HMC      | HUC    | PRM |          |   |   |   |   |   |   |   |   |   |   |   |
|        | Reset Value       | 0           | 0        |    |    |    |    |    |    |    |    |          |    |          |    |    |          |           |    |      |          |      | 0         |          | 0        | 0        | 0        |          | 0        | 0        | 0        | 0        | 0      | 0   | 0        | 0 | 0 | 0 |   |   |   |   |   |   |   |   |
| 008h   | ETH_MACHASHHI     | HTH[31:0]   |          |    |    |    |    |    |    |    |    |          |    |          |    |    |          |           |    |      |          |      |           |          |          |          |          |          |          |          |          |          |        |     |          |   |   |   |   |   |   |   |   |   |   |   |
|        | Reset Value       | 0           | 0        | 0  | 0  | 0  | 0  | 0  | 0  | 0  | 0  | 0        | 0  | 0        | 0  | 0  | 0        | 0         | 0  | 0    | 0        | 0    | 0         | 0        | 0        | 0        | 0        | 0        | 0        | 0        | 0        | 0        | 0      | 0   |          |   |   |   |   |   |   |   |   |   |   |   |
| 00Ch   | ETH_MACHASHLO     | HTL[31:0]   |          |    |    |    |    |    |    |    |    |          |    |          |    |    |          |           |    |      |          |      |           |          |          |          |          |          |          |          |          |          |        |     |          |   |   |   |   |   |   |   |   |   |   |   |
|        | Reset Value       | 0           | 0        | 0  | 0  | 0  | 0  | 0  | 0  | 0  | 0  | 0        | 0  | 0        | 0  | 0  | 0        | 0         | 0  | 0    | 0        | 0    | 0         | 0        | 0        | 0        | 0        | 0        | 0        | 0        | 0        | 0        | 0      | 0   | 0        |   |   |   |   |   |   |   |   |   |   |   |
| 010h   | ETH_MACMIIADDR    | Reserved    |          |    |    |    |    |    |    |    |    |          |    |          |    |    | PA[4:0]  |           |    |      | MR[4:0]  |      |           |          | Reserved | CR[2:0]  |          | MW       | MB       |          |          |          |        |     |          |   |   |   |   |   |   |   |   |   |   |   |
|        | Reset Value       | 0           |          |    |    |    |    |    |    |    |    |          |    |          |    |    | 0        | 0         | 0  | 0    | 0        | 0    | 0         | 0        | 0        | 0        | 0        | 0        | 0        | 0        | 0        | 0        | 0      | 0   | 0        | 0 | 0 |   |   |   |   |   |   |   |   |   |
| 014h   | ETH_MACMIIIDAT    | Reserved    |          |    |    |    |    |    |    |    |    |          |    |          |    |    | MD[15:0] |           |    |      |          |      |           |          |          |          |          |          |          |          |          |          |        |     |          |   |   |   |   |   |   |   |   |   |   |   |
|        | Reset Value       | 0           |          |    |    |    |    |    |    |    |    |          |    |          |    |    | 0        | 0         | 0  | 0    | 0        | 0    | 0         | 0        | 0        | 0        | 0        | 0        | 0        | 0        | 0        | 0        | 0      | 0   | 0        | 0 | 0 | 0 | 0 | 0 | 0 | 0 | 0 | 0 | 0 | 0 |
| 018h   | ETH_MACFLWCTRL    | PT[15:0]    |          |    |    |    |    |    |    |    |    | Reserved |    |          |    |    |          |           |    |      |          | DZQP | Reserved  | PLT[1:0] |          | UP       | RFE      | TFE      | FCB_BPA  |          |          |          |        |     |          |   |   |   |   |   |   |   |   |   |   |   |
|        | Reset Value       | 0           | 0        | 0  | 0  | 0  | 0  | 0  | 0  | 0  | 0  | 0        | 0  | 0        | 0  | 0  | 0        | 0         | 0  | 0    | 0        | 0    | 0         | 0        | 0        | 0        | 0        | 0        | 0        | 0        | 0        | 0        | 0      | 0   | 0        |   |   |   |   |   |   |   |   |   |   |   |
| 01Ch   | ETH_MACVLANTAG    | Reserved    |          |    |    |    |    |    |    |    |    |          |    |          |    |    | ETC      | VLT[15:0] |    |      |          |      |           |          |          |          |          |          |          |          |          |          |        |     |          |   |   |   |   |   |   |   |   |   |   |   |
|        | Reset Value       | 0           |          |    |    |    |    |    |    |    |    |          |    |          |    |    | 0        | 0         | 0  | 0    | 0        | 0    | 0         | 0        | 0        | 0        | 0        | 0        | 0        | 0        | 0        | 0        | 0      | 0   | 0        | 0 | 0 | 0 | 0 | 0 | 0 | 0 | 0 | 0 | 0 | 0 |
| 028h   | ETH_MACRMTWUFRMLT | DAT[31:0]   |          |    |    |    |    |    |    |    |    |          |    |          |    |    |          |           |    |      |          |      |           |          |          |          |          |          |          |          |          |          |        |     |          |   |   |   |   |   |   |   |   |   |   |   |
|        | Reset Value       | 0           | 0        | 0  | 0  | 0  | 0  | 0  | 0  | 0  | 0  | 0        | 0  | 0        | 0  | 0  | 0        | 0         | 0  | 0    | 0        | 0    | 0         | 0        | 0        | 0        | 0        | 0        | 0        | 0        | 0        | 0        | 0      | 0   | 0        |   |   |   |   |   |   |   |   |   |   |   |
| 02Ch   | ETH_MACPMTCTRLSTS | RWKUPELTRST | Reserved |    |    |    |    |    |    |    |    |          |    |          |    |    |          |           |    |      |          |      | GLBLUCAST |          | Reserved | Reserved | RWKPRCVD | MGKPRCVD | Reserved |          | RWKPKTEN | MGKPKTEN | PWRDWN |     |          |   |   |   |   |   |   |   |   |   |   |   |
|        | Reset Value       | 0           | 0        |    |    |    |    |    |    |    |    |          |    |          |    |    |          |           |    |      |          |      | 0         |          | 0        | 0        | 0        | 0        | 0        |          | 0        | 0        | 0      |     |          |   |   |   |   |   |   |   |   |   |   |   |
| 038h   | ETH_MACINTSTS     | Reserved    |          |    |    |    |    |    |    |    |    |          |    |          |    |    |          |           |    |      |          | TSTS |           | Reserved | Reserved | MMCTXIS  | MMCRXIS  | MMXIS    | PMTIS    | Reserved |          |          |        |     |          |   |   |   |   |   |   |   |   |   |   |   |
|        | Reset Value       | 0           |          |    |    |    |    |    |    |    |    |          |    |          |    |    |          |           |    |      |          | 0    |           | 0        | 0        | 0        | 0        | 0        | 0        | 0        |          |          |        |     |          |   |   |   |   |   |   |   |   |   |   |   |





| Offset | Register         | 31         | 30 | 29 | 28        | 27              | 26 | 25 | 24 | 23 | 22 | 21 | 20 | 19 | 18 | 17       | 16              | 15 | 14 | 13 | 12 | 11 | 10 | 9 | 8 | 7 | 6 | 5 | 4 | 3 | 2 | 1 | 0 |   |
|--------|------------------|------------|----|----|-----------|-----------------|----|----|----|----|----|----|----|----|----|----------|-----------------|----|----|----|----|----|----|---|---|---|---|---|---|---|---|---|---|---|
| 1020h  | ETH_DMAMFBOCNT   | Reserved   |    |    | OVFCNTOVF | OVFFRMCNT[10:0] |    |    |    |    |    |    |    |    |    | MISCTOVF | MISFRMCNT[15:0] |    |    |    |    |    |    |   |   |   |   |   |   |   |   |   |   |   |
|        | Reset Value      | 0          | 0  | 0  |           | 0               | 0  | 0  | 0  | 0  | 0  | 0  | 0  | 0  | 0  |          | 0               | 0  | 0  | 0  | 0  | 0  | 0  | 0 | 0 | 0 | 0 | 0 | 0 | 0 | 0 | 0 | 0 | 0 |
| 1048h  | ETH_DMACHTXDESC  | ADDR[31:0] |    |    |           |                 |    |    |    |    |    |    |    |    |    |          |                 |    |    |    |    |    |    |   |   |   |   |   |   |   |   |   |   |   |
|        | Reset Value      | 0          | 0  | 0  | 0         | 0               | 0  | 0  | 0  | 0  | 0  | 0  | 0  | 0  | 0  | 0        | 0               | 0  | 0  | 0  | 0  | 0  | 0  | 0 | 0 | 0 | 0 | 0 | 0 | 0 | 0 | 0 | 0 | 0 |
| 104Ch  | ETH_DMACHRXDESC  | ADDR[31:0] |    |    |           |                 |    |    |    |    |    |    |    |    |    |          |                 |    |    |    |    |    |    |   |   |   |   |   |   |   |   |   |   |   |
|        | Reset Value      | 0          | 0  | 0  | 0         | 0               | 0  | 0  | 0  | 0  | 0  | 0  | 0  | 0  | 0  | 0        | 0               | 0  | 0  | 0  | 0  | 0  | 0  | 0 | 0 | 0 | 0 | 0 | 0 | 0 | 0 | 0 | 0 | 0 |
| 1050h  | ETH_DMACHTXBADDR | ADDR[31:0] |    |    |           |                 |    |    |    |    |    |    |    |    |    |          |                 |    |    |    |    |    |    |   |   |   |   |   |   |   |   |   |   |   |
|        | Reset Value      | 0          | 0  | 0  | 0         | 0               | 0  | 0  | 0  | 0  | 0  | 0  | 0  | 0  | 0  | 0        | 0               | 0  | 0  | 0  | 0  | 0  | 0  | 0 | 0 | 0 | 0 | 0 | 0 | 0 | 0 | 0 | 0 | 0 |
| 1054h  | ETH_DMACHRXBADDR | ADDR[31:0] |    |    |           |                 |    |    |    |    |    |    |    |    |    |          |                 |    |    |    |    |    |    |   |   |   |   |   |   |   |   |   |   |   |
|        | Reset Value      | 0          | 0  | 0  | 0         | 0               | 0  | 0  | 0  | 0  | 0  | 0  | 0  | 0  | 0  | 0        | 0               | 0  | 0  | 0  | 0  | 0  | 0  | 0 | 0 | 0 | 0 | 0 | 0 | 0 | 0 | 0 | 0 | 0 |

## 25.5.2 ETH MAC configuration register (ETH\_MACCFG)

Address offset: 0x0000

Reset value: 0x0000 8000

MAC configuration register is the operating mode register of the MAC. It defines the working mode of receiving and sending.

|          |     |    |    |    |     |    |          |     |         |   |    |    |    |          |    |    |          |  |  |          |    |  |    |      |    |
|----------|-----|----|----|----|-----|----|----------|-----|---------|---|----|----|----|----------|----|----|----------|--|--|----------|----|--|----|------|----|
| 31       |     |    |    |    |     |    |          |     |         |   | 24 |    |    |          | 23 | 22 | 21       |  |  | 20       | 19 |  | 17 |      | 16 |
| Reserved |     |    |    |    |     |    |          |     |         |   |    |    |    |          | WD | JD | Reserved |  |  | IFG[2:0] |    |  |    | DCRS |    |
|          |     |    |    |    |     |    |          |     |         |   |    |    |    |          | rw | rw |          |  |  | rw       |    |  |    | rw   |    |
| 15       | 14  | 13 | 12 | 11 | 10  | 9  | 8        | 7   |         | 6 | 5  | 4  | 3  | 2        |    | 1  | 0        |  |  |          |    |  |    |      |    |
| Reserved | FES | DO | LM | DM | IPC | DR | Reserved | ACS | BL[1:0] |   | DC | TE | RE | Reserved |    |    |          |  |  |          |    |  |    |      |    |
| rw       |     | rw | rw | rw | rw  | rw | rw       |     | rw      |   | rw | rw | rw | rw       |    |    |          |  |  |          |    |  |    |      |    |

| Bit field | Name     | Description  |
|-----------|----------|--|
| 31:24     | Reserved | Reserved, the reset value must be maintained.  |
| 23        | WD       | Disable watchdog.<br>0: Frames exceeding 2048 bytes are not allowed to be received, and data exceeding 2048 bytes will be truncated.<br>1: Turn off receive watchdog timer, and MAC can receive frames with a maximum length of 16383 bytes. |
| 22        | JD       | Disable Jabber detection.<br>0: Allows transmit frames of up to 2048 bytes.<br>1: Disable Jabber timer, and MAC can transmit frames of up to 16383 bytes.  |
| 21:20     | Reserved | Reserved, the reset value must be maintained.  |
| 19:17     | IFG[2:0] | Frame gap selection.<br>These bits are used to control the shortest gap between two transmitted frames.<br>000: 96-bit time<br>001: 88-bit time<br>010: 80-bit time<br>...<br>111: 40-bit time   |

| Bit field | Name     | Description   |
|-----------|----------|---|
|           |          | In half-duplex mode, these bits can be configured with a minimum interframe gap of 64-bit time.   |
| 16        | DCRS     | Disable carrier sense function.<br>0: MAC will report an error and terminate the transmission when the carrier signal is wrong.<br>1: In half-duplex mode, MAC will ignore the CRS signal of MII in the process of sending the frame, and no error will be reported if the carrier is lost or there is no carrier.  |
| 15        | Reserved | Reserved, the reset value must be maintained.   |
| 14        | FES      | Ethernet speed selection.<br>0: 10Mbps<br>1: 100Mbps  |
| 13        | DO       | Disable self-receive function.<br>This bit has no meaning in full duplex mode.<br>0: MAC receives all packets from the PHY when transmitting.<br>1: MAC does not receive frames in half-duplex mode.  |
| 12        | LM       | Loopback mode.<br>0: MAC works in normal mode.<br>1: MAC works in Loopback mode (receive clock Rx_CLK input is required).   |
| 11        | DM       | Duplex mode selection.<br>0: Half-duplex mode.<br>1: Full duplex mode.  |
| 10        | IPC      | IP frame checksum.<br>0: Disable TCP/UDP/ICMP header checksum check of receiver.<br>1: Enable checksum check function of receiver.  |
| 9         | DR       | Disable retry.<br>This bit is only valid in half-duplex mode.<br>0: MAC will retransmit after a certain period of time according to the settings of these bits in ETH_MACCFG.BL[1:0] after a collision.<br>1: MAC will only attempt to send 1 time. If a collision occurs on MII, MAC will abort the transmission and report an excessive collision error in the transmit status message. |
| 8         | Reserved | Reserved, the reset value must be maintained.   |
| 7         | ACS      | Automatic PAD/CRC stripping.<br>0: MAC will forward all received frames without changing the content of the frame.<br>1: MAC will remove PAD field and CRC field of frames less than or equal to 1536 bytes, and frames exceeding 1536 bytes will be forwarded directly.  |
| 6:5       | BL[1:0]  | Back off limit.<br>After a collision, MAC needs to delay for some time before retransmitting the current frame. The time base unit of this delay time (dt) is called a time slot, and a time slot is 512 bits of time. This delay time (dt) is a random integer value calculated by: $0 \leq dt < 2^k$<br>00: $k = \min(n, 10)$   |

| Bit field | Name     | Description  |
|-----------|----------|--|
|           |          | 01: $k = \min(n, 8)$<br>10: $k = \min(n, 4)$<br>11: $k = \min(n, 1)$<br>Where: $n =$ number of retransmissions.<br>Note: These bits are only valid in half-duplex mode.  |
| 4         | DC       | Deferral inspection.<br>This bit is only valid in half-duplex mode.<br>0: Disable MAC deferral check function. MAC will delay sending until the CRS signal is disabled.<br>1: MAC delay check function is enabled. If the delay exceeds the 24288 bit time, an excessive delay error occurs and MAC will abort the transmission. But if a valid CRS signal is detected within the delay time, the delay counter will be reset to 0 and the delay timing will be restarted. |
| 3         | TE       | Enable transmitter.<br>0: MAC closes transmit state machine. If the current frame is being transmitted, it will be closed after transmitting is completed.<br>1: MAC enables transmit state machine.   |
| 2         | RE       | Enable receiver.<br>0: MAC closes receiving state machine. If the current frame is being received, it will be closed after receiving is completed.<br>1: MAC enables receive state machine.  |
| 1:0       | Reserved | Reserved, the reset value must be maintained.  |

### 25.5.3 ETH MAC frame filter register (ETH\_MACFFLT)

Address offset: 0x0004

Reset value: 0x0000 0000

MAC Frame Filter Register contains the filter control bits for received frames.

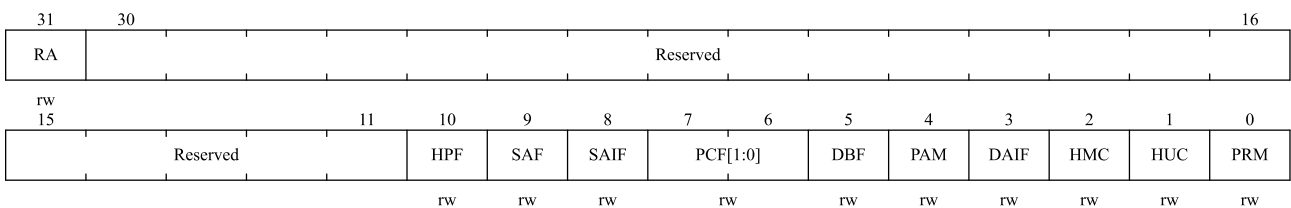

| Bit field | Name | Description  |
|-----------|------|--|
| 31        | RA   | Receive all frames.<br>This bit controls the frame filter function.<br>0: Only received frames that pass the address filter will be forwarded to the application.<br>1: All received frames will be forwarded to application, but the result of the filtering will be reflected in the corresponding flags in the updated receive descriptor status information. |

| Bit field | Name     | Description  |
|-----------|----------|--|
| 30:11     | Reserved | Reserved, the reset value must be maintained.  |
| 10        | HPF      | <p>HASH or perfect filtering.</p> <p>0: If ETH_MACFFLT.HMC or ETH_MACFFLT.HUC is set to 1, only frames that conform to the HASH filter can pass the receive address filter.</p> <p>1: If ETH_MACFFLT.HMC or ETH_MACFFLT.HUC is set to 1, and the received frame passes either HASH filter or the perfect filter, it is considered that it has passed the receiving address filter.</p>   |
| 9         | SAF      | <p>Source address filter.</p> <p>Enables energy address filter in addition to destination address filter. The filter compares the value of the source address field of the received frame with the value configured in the enabled source address register. If the source address values match, the source address match status bit in the receive descriptor will be set.</p> <p>0: Source address filter is off.</p> <p>1: Source address filter is enabled.</p>   |
| 8         | SAIF     | <p>Invert source address filtering result.</p> <p>This bit inverts the source address comparison result.</p> <p>0: Disable source address filter result inversion, all frames whose source address does not match the source address register will be marked as failing the source address filter.</p> <p>1: Invert source address filter result, all frames whose source address matches the source address register will be marked as failing the source address filter.</p>   |
| 7:6       | PCF[1:0] | <p>Control frame forwarding bit.</p> <p>These bits are used to set the forwarding conditions of all control frames (including unicast and multicast pause frames), and whether to process pause control frames depends only on the value of ETH_MACFLWCTRL.RFE.</p> <p>00: MAC does not forward any control frames to the application.</p> <p>01: MAC forwards control frames other than pause frames to the application.</p> <p>10: MAC forwards all control frames to the application, even those that do not pass address filter.</p> <p>11: MAC forwards control frames that pass address filter to the application.</p> |
| 5         | DBF      | <p>Refuse to receive broadcast frames.</p> <p>0: The filter receives all broadcast frames.</p> <p>1: The filter does not receive all broadcast frames.</p>   |
| 4         | PAM      | <p>Pass all multicast frames.</p> <p>0: Multicast frame filtering depends on the value of ETH_MACFFLT.HMC.</p> <p>1: All frames with a multicast destination address (the first bit of the address is 1) can pass the filter.</p>  |
| 3         | DAIF     | <p>Invert destination address filtering result.</p> <p>This bit inverts the destination address filter result.</p> <p>0: Disable destination address filtering result inversion.</p> <p>1: Enable destination address filtering result inversion.</p>  |
| 2         | HMC      | <p>Multicast HASH filter.</p> <p>0: MAC will compare the value of the destination address field of the received</p>  |

| Bit field | Name | Description  |
|-----------|------|--|
|           |      | multicast frame with the set value of the destination address register.<br>1: MAC filters the destination address of the received multicast frame according to the HASH list.  |
| 1         | HUC  | Unicast HASH filter.<br>0: MAC will compare the value of the destination address field of the received unicast frame with the set value of the destination address register.<br>1: MAC filters the destination address of the received unicast frame according to the HASH list. |
| 0         | PRM  | Promiscuous mode.<br>This bit disables the address filter, which means that all frames pass the filter while the destination/source error bit of the status information in the receive descriptor is always 0.<br>0: Disable promiscuous mode.<br>1: Enable promiscuous mode.    |

### 25.5.4 ETH MAC HASH list high register (ETH\_MACHASHHI)

Address offset: 0x0008

Reset value: 0x0000 0000

A 64-bit HASH list can be used for group address filtering. This register contains the upper 32 bits of the multicast HASH list.

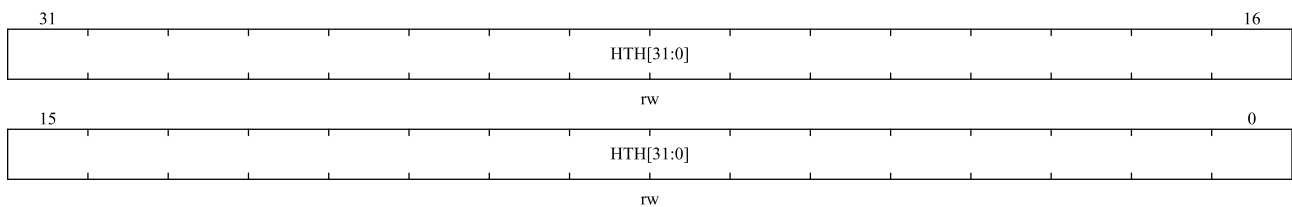

| Bit field | Name      | Description   |
|-----------|-----------|---|
| 31:0      | HTH[31:0] | HASH list high.<br>These bits are the upper 32 bits of the HASH list. |

### 25.5.5 ETH MAC HASH list low register (ETH\_MACHASHLO)

Address offset: 0x000C

Reset value: 0x0000 0000

A 64-bit HASH list can be used for group address filtering. This register contains the lower 32 bits of the multicast HASH list.

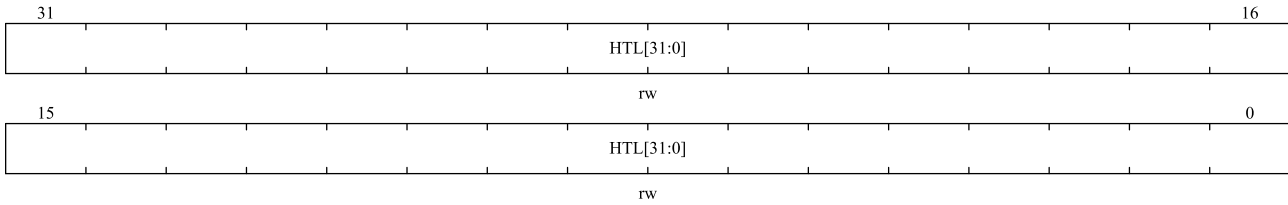

| Bit field | Name      | Description  |
|-----------|-----------|--|
| 31:0      | HTL[31:0] | HASH list low.<br>These bits are the lower 32 bits of the HASH list. |

## 25.5.6 ETH MAC MII address register (ETH\_MACMIIADDR)

Address offset: 0x0010

Reset value: 0x0000 0000

This register controls the management signals of the external PHY through the interface.

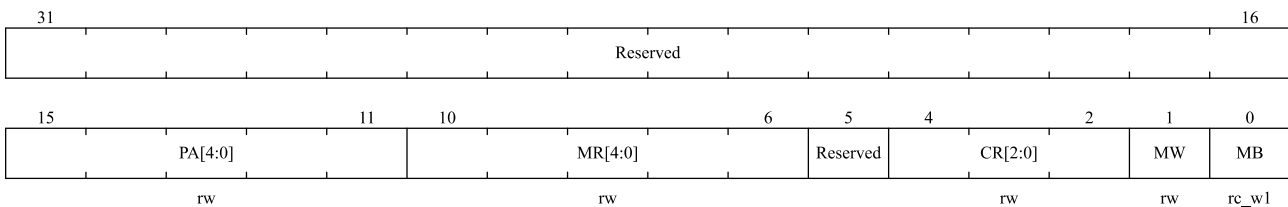

| Bit field | Name          | Description   |       |               |                |     |         |           |     |         |            |     |         |          |     |         |          |       |          |          |
|-----------|---------------|---|-------|---------------|----------------|-----|---------|-----------|-----|---------|------------|-----|---------|----------|-----|---------|----------|-------|----------|----------|
| 31:16     | Reserved      | Reserved, the reset value must be maintained.   |       |               |                |     |         |           |     |         |            |     |         |          |     |         |          |       |          |          |
| 15:11     | PA[4:0]       | PHY address.<br>These bits represent the accessed PHY address.  |       |               |                |     |         |           |     |         |            |     |         |          |     |         |          |       |          |          |
| 10:6      | MR[4:0]       | MII PHY registers.<br>These bits select the PHY register to be accessed.  |       |               |                |     |         |           |     |         |            |     |         |          |     |         |          |       |          |          |
| 5         | Reserved      | Reserved, the reset value must be maintained.   |       |               |                |     |         |           |     |         |            |     |         |          |     |         |          |       |          |          |
| 4:2       | CR[2:0]       | Clock range.<br>These bits are used to configure the clock of MDC according to the frequency of HCLK.<br><table border="1" data-bbox="598 1556 1428 1814"> <thead> <tr> <th>value</th> <th>MDC frequency</th> <th>HCLK frequency</th> </tr> </thead> <tbody> <tr> <td>000</td> <td>HCLK/42</td> <td>60~100MHz</td> </tr> <tr> <td>001</td> <td>HCLK/62</td> <td>100~144MHz</td> </tr> <tr> <td>010</td> <td>HCLK/16</td> <td>20~35MHz</td> </tr> <tr> <td>011</td> <td>HCLK/26</td> <td>35~60MHz</td> </tr> <tr> <td>other</td> <td>Reserved</td> <td>Reserved</td> </tr> </tbody> </table> | value | MDC frequency | HCLK frequency | 000 | HCLK/42 | 60~100MHz | 001 | HCLK/62 | 100~144MHz | 010 | HCLK/16 | 20~35MHz | 011 | HCLK/26 | 35~60MHz | other | Reserved | Reserved |
| value     | MDC frequency | HCLK frequency  |       |               |                |     |         |           |     |         |            |     |         |          |     |         |          |       |          |          |
| 000       | HCLK/42       | 60~100MHz   |       |               |                |     |         |           |     |         |            |     |         |          |     |         |          |       |          |          |
| 001       | HCLK/62       | 100~144MHz  |       |               |                |     |         |           |     |         |            |     |         |          |     |         |          |       |          |          |
| 010       | HCLK/16       | 20~35MHz  |       |               |                |     |         |           |     |         |            |     |         |          |     |         |          |       |          |          |
| 011       | HCLK/26       | 35~60MHz  |       |               |                |     |         |           |     |         |            |     |         |          |     |         |          |       |          |          |
| other     | Reserved      | Reserved  |       |               |                |     |         |           |     |         |            |     |         |          |     |         |          |       |          |          |
| 1         | MW            | MII write operation.<br>0: Read the PHY.<br>1: Write to PHY.  |       |               |                |     |         |           |     |         |            |     |         |          |     |         |          |       |          |          |
| 0         | MB            | MII busy.<br>This bit should be 0 before writing to register ETH_MACMIIADDR and   |       |               |                |     |         |           |     |         |            |     |         |          |     |         |          |       |          |          |

| Bit field | Name | Description   |
|-----------|------|---|
|           |      | ETH_MACMIIDAT. When accessing the PHY, this bit is set by the application program to indicate that a read or write operation is being performed on the PHY. When writing to the PHY, the value of the ETH_MACMIIDAT register must be retained until this bit is cleared by hardware. When the PHY is read, the value of the ETH_MACMIIDAT register is valid after the hardware clears this bit. |

### 25.5.7 ETH MAC MII data register (ETH\_MACMIIDAT)

Address offset: 0x0014

Reset value: 0x0000 0000

This register holds the value to be written to or read from PHY register.

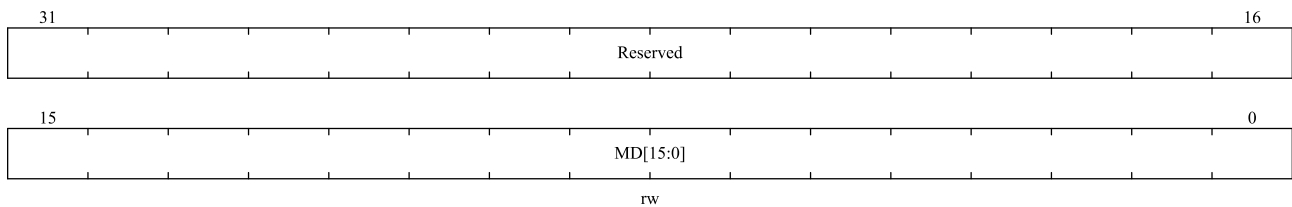

| Bit field | Name     | Description   |
|-----------|----------|---|
| 31:16     | Reserved | Reserved, the reset value must be maintained.   |
| 15:0      | MD[15:0] | MII data.<br>These bits contain the 16-bit data read out after a read operation on PHY. Or the 16-bit data to be written before writing to PHY. |

### 25.5.8 ETH MAC flow control register (ETH\_MACFLWCTRL)

Address offset: 0x0018

Reset value: 0x0000 0000

This register is used for the generation and reception of configuration control (PAUSE) frames.

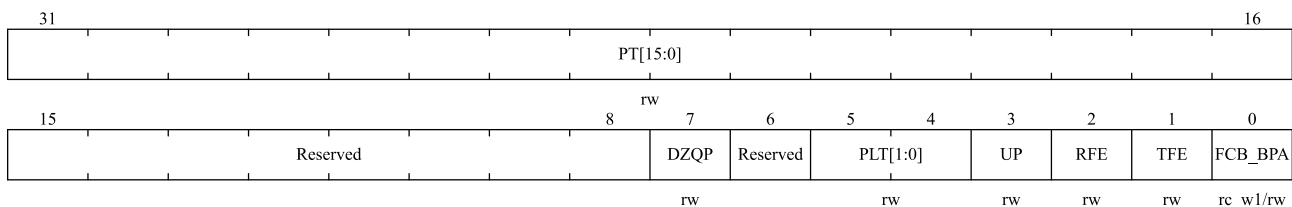

| Bit field | Name     | Description   |
|-----------|----------|---|
| 31:16     | PT[15:0] | PAUSE time.<br>The value of these bits is used as the value of the PAUSE time field of the control frame. If the PAUSE time is set to be synchronized to MII clock domain twice, there must be at least 4 destination domain clock cycles between consecutive writes to the register. |

| Bit field | Name     | Description   |
|-----------|----------|---|
| 15:8      | Reserved | Reserved, the reset value must be maintained.   |
| 7         | DZQP     | <p>Disable zero-value PAUSE function.</p> <p>0: Normal operation, turning on the automatic generation of zero-value PAUSE control frames.</p> <p>1: When the FIFO layer flow control signal is withdrawn, the automatic generation of the automatic zero-valued PAUSE control frame is turned off.</p>  |
| 6         | Reserved | Reserved, the reset value must be maintained.   |
| 5:4       | PLT[1:0] | <p>PAUSE low threshold.</p> <p>These bits set the timer threshold for automatic retransmission of PAUSE frames. This threshold should be greater than 0 and less than the pause time defined by these bits in ETH_MACFLWCTRL.PT[15:0]. The low threshold is calculated as PT - PLT. For example, PT = 0x80 (128 time slots), PLT = 0x1 (28 time slots), then the second PAUSE frame will be automatically retransmit 100 (128-28) time slots after the first PAUSE frame is transmitted.</p> <p>00: Pause time - 4 time slots</p> <p>01: Pause time - 28 time slots</p> <p>10: Pause time - 144 time slots</p> <p>11: Pause time - 256 time slots</p> <p><i>Note: A time gap refers to the time it takes for the MII interface to send 512 bits (64 bytes) of data.</i></p> |
| 3         | UP       | <p>Unicast PAUSE frame detection.</p> <p>0: MAC only receives PAUSE frames that conform to the unique multicast address defined by the IEEE802.3 specification.</p> <p>1: In addition to PAUSE frames with unique multicast addresses, MAC also uses the MAC address 0 to detect PAUSE frames.</p>  |
| 2         | RFE      | <p>Receive flow control enable bit.</p> <p>When this bit is set to 1, MAC will turn off the transmitter for the specified time (the value of the Pause Time field in the received frame).</p> <p>0: MAC does not parse PAUSE frames.</p> <p>1: MAC parses and processes the received PAUSE frame.</p>   |
| 1         | TFE      | <p>Transmit flow control enable bit.</p> <p>In full-duplex mode, this bit is 1 to indicate that MAC can transmit PAUSE frames, and this bit is cleared to 0 to indicate that PAUSE frames are not transmitted.</p> <p>In half-duplex mode, this bit is 1 to indicate that MAC enables the back pressure function, and this bit is cleared to 0 to indicate that the back pressure function is turned off.</p> <p>0: MAC disables transmit flow control function.</p> <p>1: MAC enables transmit flow control function.</p>  |
| 0         | FCB_BPA  | <p>Flow control busy/back pressure active.</p> <p>In full-duplex mode, this bit can transmit PAUSE frames; in half-duplex mode, when ETH_MACFLWCTRL.TFE is set, this bit can activate the back pressure function.</p> <p>In full-duplex mode, the application should ensure that this bit is 0 before writing to the ETH_MACFLWCTRL register. After this bit is set to 1, MAC will transmit a</p>   |

| Bit field | Name | Description   |
|-----------|------|---|
|           |      | <p>PAUSE frame to the interface. During the process of transmit the control frame, the bit is always 1, and MAC resets this bit to 0 after the PAUSE control frame is transmitted.</p> <p>In half-duplex mode, setting this bit to 1 activates the backpressure function. When the backpressure function is valid, if MAC receives a new frame, it will transmit a blocking signal at the sender to notify that there is a conflict.</p> <p>The back pressure function is automatically disabled in full duplex mode.</p> |

### 25.5.9 ETH MAC VLAN tag register (ETH\_MACVLANTAG)

Address offset: 0x001C

Reset value: 0x0000 0000

This register contains the IEEE802.1Q VLAN tag used to identify VLAN frames. MAC compares the 13th and 14th bytes (length/type fields) of the received frame with 0x8100, and then compares the next 2 bytes (15th and 16th bytes) with the VLAN tag.

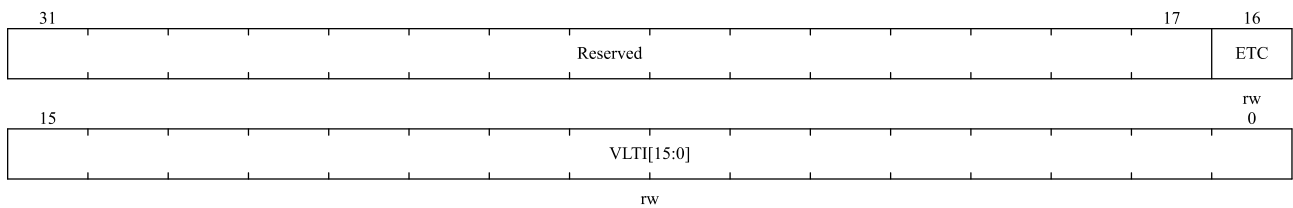

| Bit field | Name       | Description  |
|-----------|------------|--|
| 31:17     | Reserved   | Reserved, the reset value must be maintained.  |
| 16        | ETC        | <p>12-bit VLAN tag comparison bits.</p> <p>This bit selects VLAN tag to be compared with ETH_MACVLANTAG.VLTl[11:0] (12 bits) or ETH_MACVLANTAG.VLTl[15:0] (16 bits).</p> <p>0: Use all 16-bit data for comparison.</p> <p>1: Use only 12-bit data for comparison.</p>  |
| 15:0      | VLTl[15:0] | <p>VLAN tag identifier bits.</p> <p>These bits are used to identify the 802.1Q VLAN tag format of VLAN frame. The format is as follows:</p> <p>VLTl[15:13]: UP (user priority)</p> <p>VLTl[12]: CFI (Standard Format Indicator)</p> <p>VLTl[11:0]: VID (VLAN identifier)</p> <p>Define VLTl[n:0], when ETH_MACVLANTAG.ETC = 1, n = 11; when ETH_MACVLANTAG.ETC = 0, n = 15.</p> <p>If the value of VLTl[n:0] is all 0, MAC will no longer compare and check the 15th and 16th bytes of VLAN frame, and will directly regard the frame with the type field value of the received frame as 0x8100 as a VLAN frame.</p> <p>If VLTl[n:0] is not all 0, use VLTl[n:0] for comparison.</p> |

### 25.5.10 ETH MAC remote wakeup frame filter register

#### (ETH\_MACRMTWUFRMFLT)

Address offset: 0x0028

Reset value: 0x0000 0000

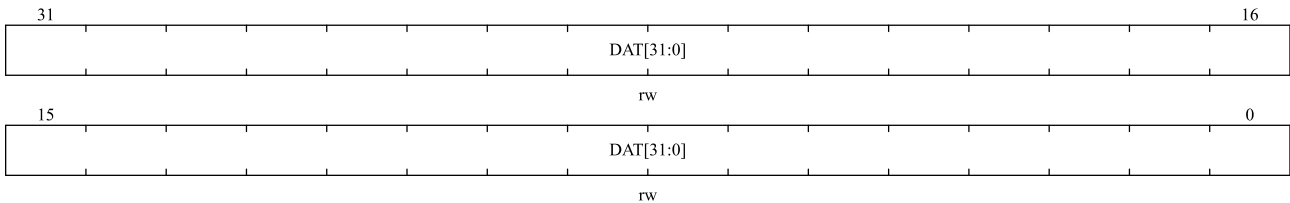

This register is essentially a pointer to 8 opaque wakeup frame filter registers (using the same offset). 8 consecutive write operations to this register address (offset 0x0028) can write all 8 wake-up frame filter registers; 8 consecutive read operations to this register address (offset 0x0028) can read all 8 wake-up frame filter registers. Refer to Table 25-7 Remote wakeup frame filter register overview.

### 25.5.11 ETH MAC PMT control and status register (ETH\_MACPMTCTRLSTS)

Address offset: 0x002C

Reset value: 0x0000 0000

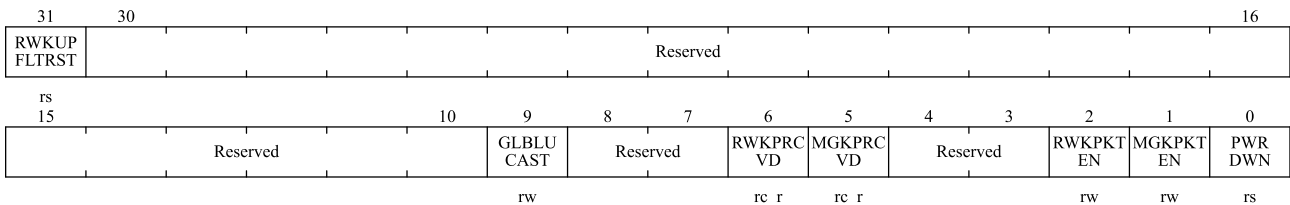

| Bit field | Name        | Description   |
|-----------|-------------|---|
| 31        | RWKUPFLTRST | Remote wakeup frame filter register pointer reset.<br>0: No effect.<br>1: Reset ETH_MACRMTWUFRMFLT register pointer, which is automatically cleared to 0 after the pointer reset is completed.    |
| 30:10     | Reserved    | Reserved, the reset value must be maintained.   |
| 9         | GLBLUCAST   | Global unicast.<br>0: Not all received unicast frames are considered wakeup frames.<br>1: All unicast frames that can pass MAC address filter are considered as wake-up frames.                   |
| 8:7       | Reserved    | Reserved, the reset value must be maintained.   |
| 6         | RWKPRCVD    | Remote wakeup frame received.<br>This bit is cleared to 0 by reading this register.<br>0: No remote wakeup frame was received.<br>1: A remote wakeup frame is received and a wakeup event occurs. |

| Bit field | Name     | Description   |
|-----------|----------|---|
| 5         | MGKPRCVD | Magic Packet received.<br>This bit is cleared to 0 by reading this register.<br>0: No Magic Packet wakeup frame was received.<br>1: A Magic Packet wakeup frame is received and a wakeup event occurs.  |
| 4:3       | Reserved | Reserved, the reset value must be maintained.   |
| 2         | RWKPKTEN | Remote wake-up frame enable bit.<br>0: Disables to generate wakeup event when remote wakeup frame is received.<br>1: Enable to generate wakeup event when remote wakeup frame is received.  |
| 1         | MGKPKTEN | Magic Packet enable bit.<br>0: Disable to generate wakeup event when Magic Packet wakeup frame is received.<br>1: Enable to generate wakeup event when Magic Packet wakeup frame is received.   |
| 0         | PWRDWN   | Low power bit.<br>This bit is set by software and reset by hardware. When this bit is set, MAC discards all received frames. When a wakeup event occurs and the low-power mode is exited, the hardware will automatically clear this bit to 0. This bit can only be set when ETH_MACPMTCTRLSTS.RWKPKTEN or ETH_MACPMTCTRLSTS.MGKPKTEN is 1. |

## 25.5.12 ETH MAC interrupt status register (ETH\_MACINTSTS)

Address offset: 0x0038

Reset value: 0x0000 0000

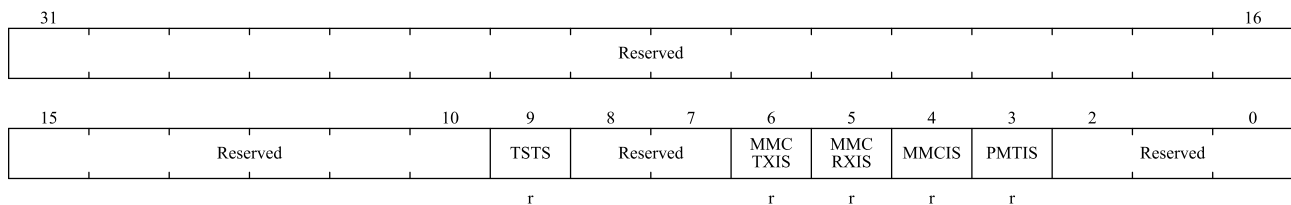

| Bit field | Name     | Description  |
|-----------|----------|--|
| 31:10     | Reserved | Reserved, the reset value must be maintained.  |
| 9         | TSTS     | Timestamp trigger state.<br>This bit is cleared to 0 by reading this register.<br>0: System time value is less than the expected time value.<br>1: System time value is equal to or exceeds the expected time value. |
| 8:7       | Reserved | Reserved, the reset value must be maintained.  |
| 6         | MMCTXIS  | MMC sends status.<br>0: All bits in ETH_MMCTXINT register are 0.<br>1: Any interrupt bit in ETH_MMCTXINT register is 1.  |
| 5         | MMCRXIS  | MMC receive status.<br>0: All bits in ETH_MMCRXINT register are 0.<br>1: Any interrupt bit in ETH_MMCRXINT register is 1.  |
| 4         | MMCIS    | MMC status.  |

| Bit field | Name     | Description   |
|-----------|----------|---|
|           |          | 0: ETH_MACINTSTS.MMCTXIS and ETH_MACINTSTS.MMCRXIS are both 0.<br>1: One of ETH_MACINTSTS.MMCTXIS and ETH_MACINTSTS.MMCRXIS is 1.   |
| 3         | PMTIS    | PMT status.<br>In low power mode, this bit is set to 1 when a remote wakeup frame or Magic Packet wakeup frame is received. This bit is also cleared to 0 after clearing ETH_MACPMTCTRLSTS.RWKPRCVD and ETH_MACPMTCTRLSTS.MGKPRCVD by reading the ETH_MACPMTCTRLSTS register. |
| 2:0       | Reserved | Reserved, the reset value must be maintained.   |

### 25.5.13 ETH MAC interrupt mask register (ETH\_MACINTMSK)

Address offset: 0x003C

Reset value: 0x0000 0000

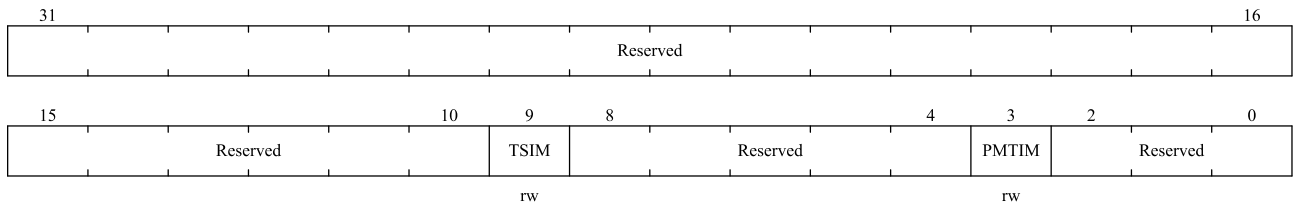

| Bit field | Name     | Description  |
|-----------|----------|--|
| 31:10     | Reserved | Reserved, the reset value must be maintained.  |
| 9         | TSIM     | Timestamp trigger interrupt mask bit.<br>0: Enable generation of timestamp interrupts.<br>1: Disable generation of timestamp interrupts.   |
| 8:4       | Reserved | Reserved, the reset value must be maintained.  |
| 3         | PMTIM    | PMT interrupt mask bit.<br>0: Enable generation of interrupts caused by ETH_MACINTSTS.PMTIS being set to 1.<br>1: Disable generation of interrupts caused by ETH_MACINTSTS.PMTIS being set to 1. |
| 2:0       | Reserved | Reserved, the reset value must be maintained.  |

### 25.5.14 ETH MAC address 0 high register (ETH\_MACADDR0HI)

Address offset: 0x0040

Reset value: 0x8000 FFFF

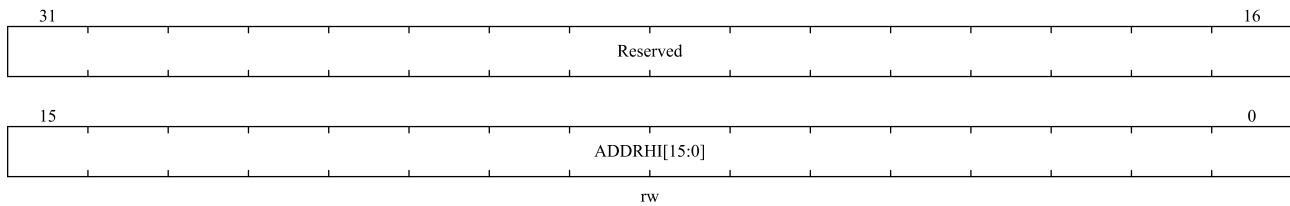

| Bit field | Name         | Description  |
|-----------|--------------|--|
| 31:16     | Reserved     | Reserved, the reset value must be maintained.  |
| 15:0      | ADDRHI[15:0] | MAC address 0 high 16 bits.<br>These bits contain the upper 16 bits of the 6-byte MAC address 0. These bits are used as the address filtering of the received frame, it is also used in transmit flow control, and is inserted as the source address of the frame when transmit a PAUSE frame. |

### 25.5.15 ETH MAC address 0 low register (ETH\_MACADDR0LO)

Address offset: 0x0044

Reset value: 0xFFFF FFFF

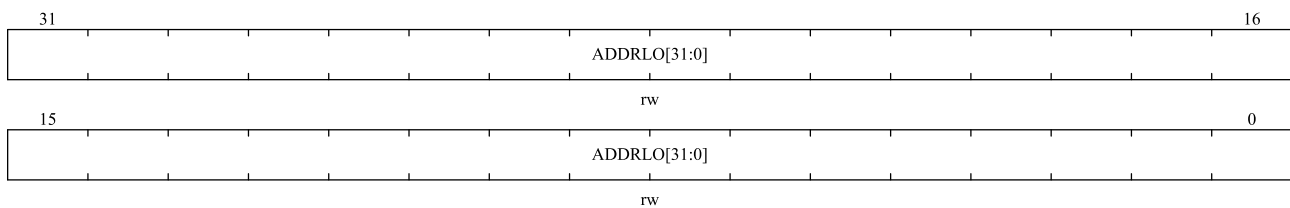

| Bit field | Name         | Description   |
|-----------|--------------|---|
| 31:0      | ADDRLO[31:0] | MAC address 0 low 32 bits.<br>These bits contain the lower 32 bits of the 6-byte MAC address 0. These bits are used as the address filtering of the received frame, it is also used in transmit flow control, and is inserted as the source address of the frame when transmit a PAUSE frame. |

### 25.5.16 ETH MAC address 1 high register (ETH\_MACADDR1HI)

Address offset: 0x0048

Reset value: 0x0000 FFFF

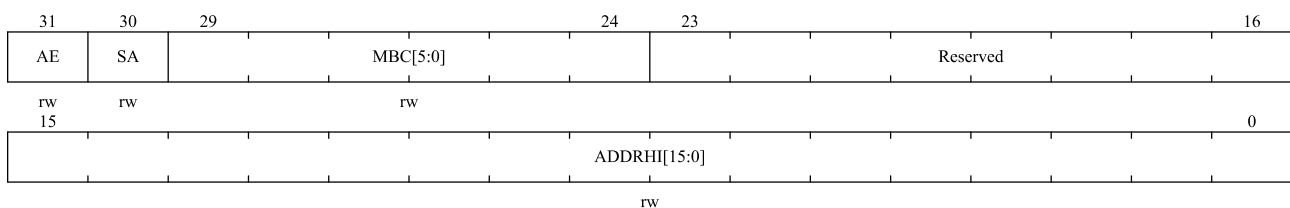

| Bit field | Name | Description  |
|-----------|------|--|
| 31        | AE   | Address enable.<br>0: Address filter does not use MAC address 1 for perfect filtering. |

| Bit field | Name         | Description   |
|-----------|--------------|---|
|           |              | 1: Address filter uses MAC address 1 for perfect filtering.   |
| 30        | SA           | Source address comparison.<br>0: MAC address 1 is used to compare with the destination address of the received frame.<br>1: MAC address 1 is used to compare with the source address of the received frame.   |
| 29:24     | MBC[5:0]     | Mask byte control bits.<br>When a bit is set to 1, MAC will ignore the comparison of the corresponding byte of the destination/source address of the received frame with the corresponding byte of the MAC address 1. The MAC address bytes corresponding to each control bit are as follows:<br>MBC[5]: ETH_MACADDR1HI[15:8]<br>MBC[4]: ETH_MACADDR1HI[7:0]<br>MBC[3]: ETH_MACADDR1LO[31:24]<br>MBC[2]: ETH_MACADDR1LO[23:16]<br>MBC[1]: ETH_MACADDR1LO[15:8]<br>MBC[0]: ETH_MACADDR1LO[7:0] |
| 23:16     | Reserved     | Reserved, the reset value must be maintained.   |
| 15:0      | ADDRHI[15:0] | MAC address 1 high 16 bits.<br>These bits contain the upper 16 bits of the 6-byte MAC address 1.  |

### 25.5.17 ETH MAC address 1 low register (ETH\_MACADDR1LO)

Address offset: 0x004C

Reset value: 0xFFFF FFFF

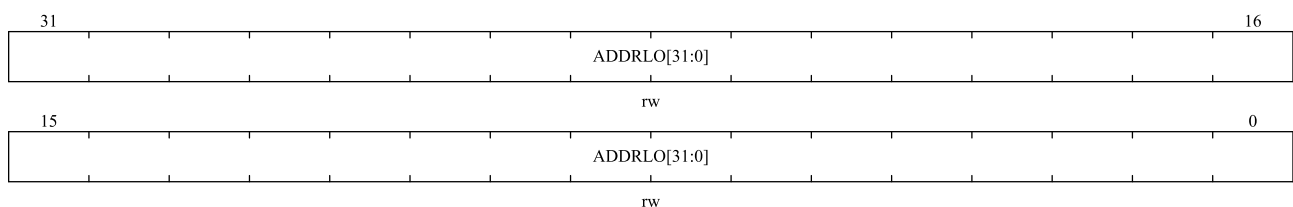

| Bit field | Name         | Description   |
|-----------|--------------|---|
| 31:0      | ADDRLO[31:0] | MAC address 1 low 32 bits.<br>These bits contain the lower 32 bits of the 6-byte MAC address 1. |

### 25.5.18 ETH MAC address 2 high register (ETH\_MACADDR2HI)

Address offset: 0x0050

Reset value: 0x0000 FFFF

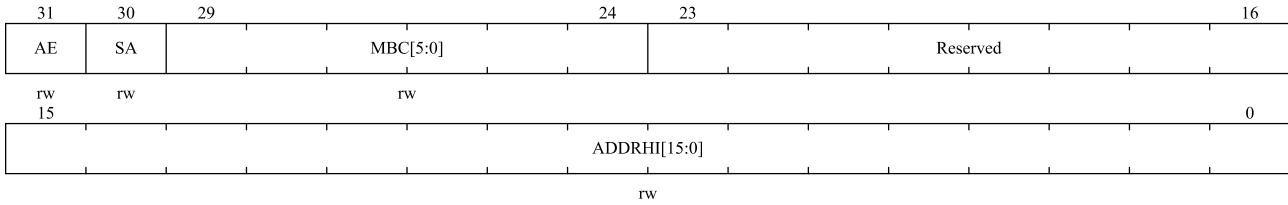

| Bit field | Name         | Description   |
|-----------|--------------|---|
| 31        | AE           | Address enable.<br>0: Address filter does not use MAC address 2 for perfect filtering.<br>1: Address filter uses MAC address 2 for perfect filtering.   |
| 30        | SA           | Source address comparison.<br>0: MAC address 2 is used to compare with the destination address of the received frame.<br>1: MAC address 2 is used to compare with the source address of the received frame.   |
| 29:24     | MBC[5:0]     | Mask byte control bits.<br>When a bit is set to 1, MAC will ignore the comparison of the corresponding byte of the destination/source address of the received frame with the corresponding byte of the MAC address 2. The MAC address bytes corresponding to each control bit are as follows:<br>MBC[5]: ETH_MACADDR2HI[15:8]<br>MBC[4]: ETH_MACADDR2HI[7:0]<br>MBC[3]: ETH_MACADDR2LO[31:24]<br>MBC[2]: ETH_MACADDR2LO[23:16]<br>MBC[1]: ETH_MACADDR2LO[15:8]<br>MBC[0]: ETH_MACADDR2LO[7:0] |
| 23:16     | Reserved     | Reserved, the reset value must be maintained.   |
| 15:0      | ADDRHI[15:0] | MAC address 2 high 16 bits.<br>These bits contain the upper 16 bits of the 6-byte MAC address 2.  |

### 25.5.19 ETH MAC address 2 low register (ETH\_MACADDR2LO)

Address offset: 0x0054

Reset value: 0xFFFF FFFF

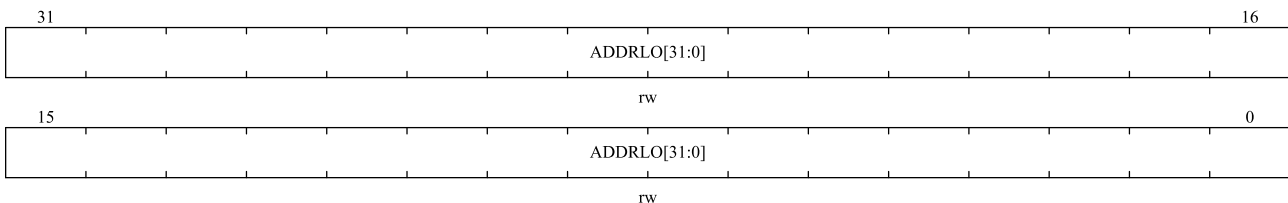

| Bit field | Name         | Description   |
|-----------|--------------|---|
| 31:0      | ADDRLO[31:0] | MAC address 2 low 32 bits.<br>These bits contain the lower 32 bits of the 6-byte MAC address 2. |



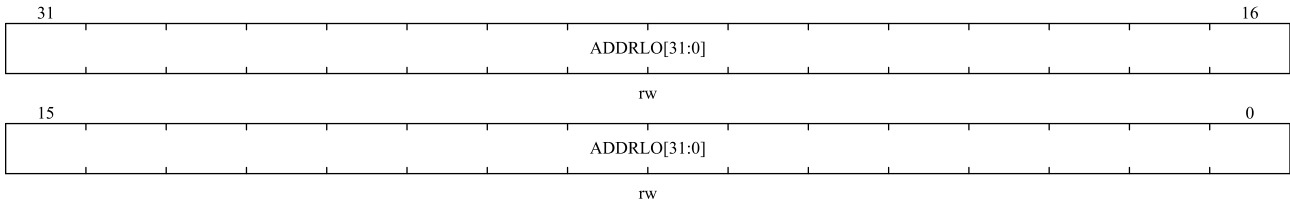

| Bit field | Name         | Description   |
|-----------|--------------|---|
| 31:0      | ADDRLO[31:0] | MAC address 3 low 32 bits.<br>These bits contain the lower 32 bits of the 6-byte MAC address 3. |

### 25.5.22 ETH MMC control register (ETH\_MMCCTRL)

Address offset: 0x0100

Reset value: 0x0000 0000

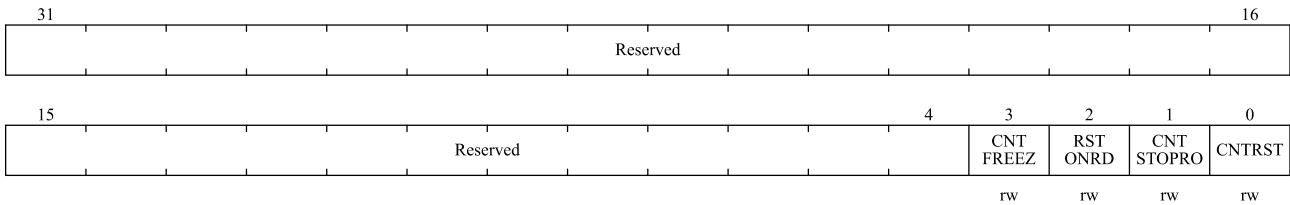

| Bit field | Name      | Description  |
|-----------|-----------|--|
| 31:4      | Reserved  | Reserved, the reset value must be maintained.  |
| 3         | CNTFREEZ  | MMC counter freezes.<br>0: MMC counter works normally.<br>1: All MMC counters are frozen, keeping the current value. RSTONRD function still works in this mode.  |
| 2         | RSTONRD   | Reset on read.<br>0: After reading the MMC counter, the counter is not reset.<br>1: After reading the MMC counter, the counter is reset.   |
| 1         | CNTSTOPRO | Counter stop rollover.<br>0: After the counter reaches the maximum value, it will start counting from 0 again.<br>1: After the counter reaches the maximum value, it will not start counting from 0 again. |
| 0         | CNTRST    | Counter reset.<br>After this bit is set, it will be automatically cleared by hardware after 1 clock cycle.<br>0: No effect.<br>1: Reset all counters.  |

### 25.5.23 ETH MMC receive interrupt status register (ETH\_MMCRXINT)

Address offset: 0x0104

Reset value: 0x0000 0000

This register records the interrupt generated when the receive statistics register counts to half the maximum value (the highest bit of the counter is set). Reading the MMC counter that generates an interrupt can clear the corresponding interrupt bit (must read the lower 8 bits of the corresponding counter).

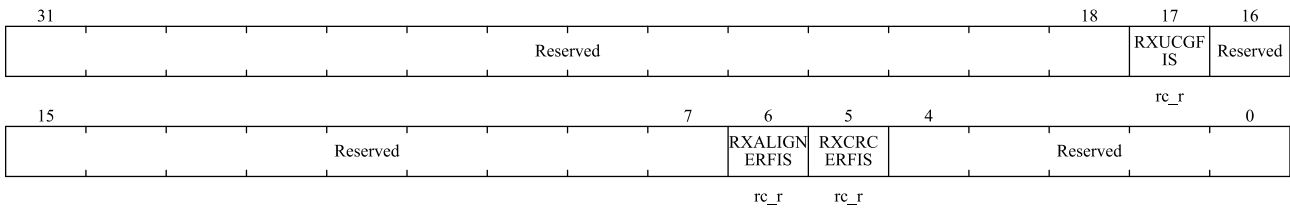

| Bit field | Name         | Description  |
|-----------|--------------|--|
| 31:18     | Reserved     | Reserved, the reset value must be maintained.  |
| 17        | RXUCGFIS     | "Good" unicast frame status received.<br>0: "Good" unicast frame received counter value has not reached half of the maximum value.<br>1: "Good" unicast frame received counter value reaches half of the maximum value.          |
| 16:7      | Reserved     | Reserved, the reset value must be maintained.  |
| 6         | RXALIGNERFIS | A frame alignment error status was received.<br>0: Alignment error received frame counter value has not reached half of the maximum value.<br>1: Alignment error received frame counter value reaches half of the maximum value. |
| 5         | RXCRCERFIS   | Received frame CRC error status.<br>0: CRC error received frame counter value has not reached half of the maximum value.<br>1: CRC error received frame counter value reaches half of the maximum value.                         |
| 4:0       | Reserved     | Reserved, the reset value must be maintained.  |

## 25.5.24 ETH MMC transmit interrupt status register (ETH\_MMCTXINT)

Address offset: 0x0108

Reset value: 0x0000 0000

This register records the interrupt generated when the transmit statistics register counts to half the maximum value (the highest bit of the counter is set). Reading the MMC counter that generates an interrupt can clear the corresponding interrupt bit (must read the lower 8 bits of the corresponding counter).

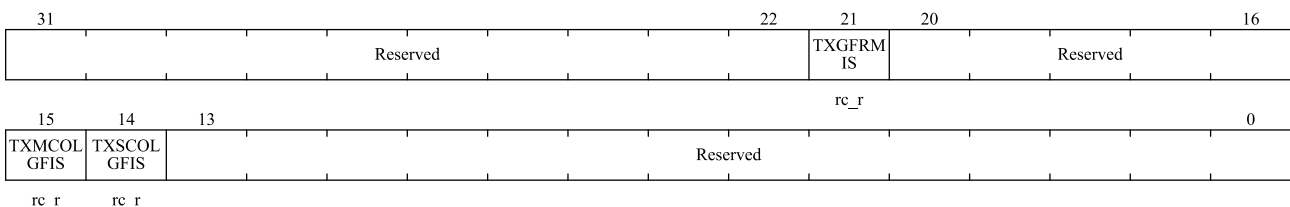

| Bit field | Name     | Description                                   |
|-----------|----------|---|
| 31:22     | Reserved | Reserved, the reset value must be maintained. |
| 21        | TXGFRMIS | "Good" frame status transmit.                 |

| Bit field | Name       | Description  |
|-----------|------------|--|
|           |            | 0: Transmit "good" frame counter value has not reached half of the maximum value.<br>1: Transmit "good" frame counter value reaches half of the maximum value.   |
| 20:16     | Reserved   | Reserved, the reset value must be maintained.  |
| 15        | TXMCOLGFIS | More than 1 collision state was encountered while transmit a "good" frame.<br>0: After more than 1 collision, transmit "good" frame counter value has not reached half of the maximum value.<br>1: After more than 1 collision, transmit "good" frame counter value reaches half of the maximum value. |
| 14        | TXSCOLGFIS | Only 1 collision state was encountered while transmit a "good" frame.<br>0: After 1 collision, transmit "good" frame counter value has not reached half of the maximum value.<br>1: After 1 collision, transmit "good" frame counter value reaches half of the maximum value.                          |
| 13:0      | Reserved   | Reserved, the reset value must be maintained.  |

### 25.5.25 ETH MMC receive interrupt mask register (ETH\_MMCRXINTMSK)

Address offset: 0x010C

Reset value: 0x0000 0000

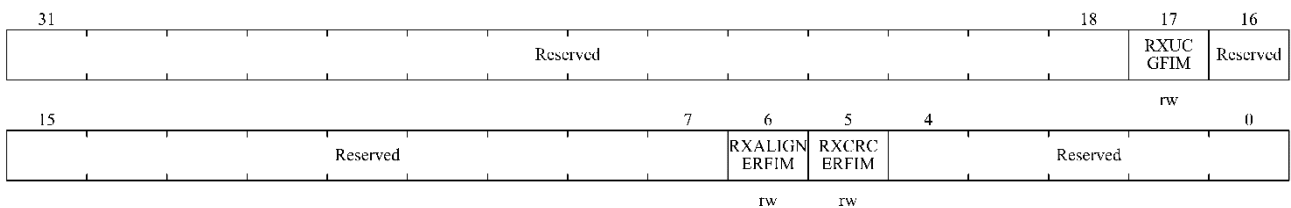

| Bit field | Name         | Description  |
|-----------|--------------|--|
| 31:18     | Reserved     | Reserved, the reset value must be maintained.  |
| 17        | RXUCGFIM     | Receive "good" unicast frame interrupt mask bit.<br>0: Do not mask the interrupt that occurs when ETH_MMCRXINT.RXUCGFIS is 1.<br>1: Mask the interrupt that occurs when ETH_MMCRXINT.RXUCGFIS is 1.          |
| 16:7      | Reserved     | Reserved, the reset value must be maintained.  |
| 6         | RXALIGNERFIM | Receive frame alignment error interrupt mask bit.<br>0: Do not mask the interrupt that occurs when ETH_MMCRXINT.RXALIGNERFIS is 1.<br>1: Mask the interrupt that occurs when ETH_MMCRXINT.RXALIGNERFIS is 1. |
| 5         | RXCRCERFIM   | Receive frame CRC error interrupt mask bit.<br>0: Do not mask the interrupt that occurs when ETH_MMCRXINT.RXCRCERFIS is 1.<br>1: Mask the interrupt that occurs when ETH_MMCRXINT.RXCRCERFIS is 1.           |
| 4:0       | Reserved     | Reserved, the reset value must be maintained.  |

### 25.5.26 ETH MMC transmit interrupt mask register (ETH\_MMCTXINTMSK)

Address offset: 0x0110

Reset value: 0x0000 0000

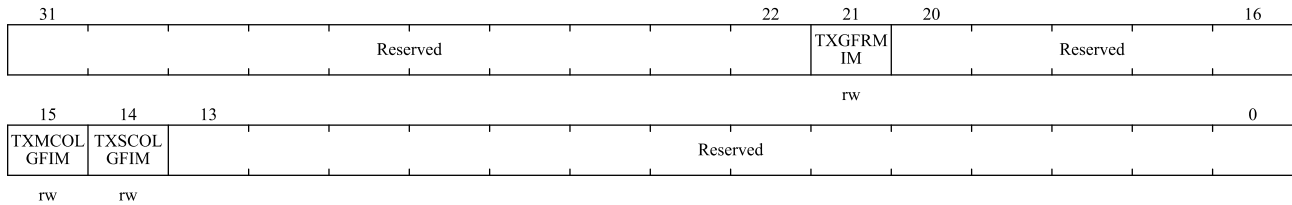

| Bit field | Name       | Description  |
|-----------|------------|--|
| 31:22     | Reserved   | Reserved, the reset value must be maintained.  |
| 21        | TXGFRMIM   | Transmit "good" frame interrupt mask bit.<br>0: Do not mask the interrupt that occurs when ETH_MMCTXINT.TXGFRMIS is 1.<br>1: Mask the interrupt that occur when the ETH_MMCTXINT.TXGFRMIS bit is 1.                          |
| 20:16     | Reserved   | Reserved, the reset value must be maintained.  |
| 15        | TXMCOLGFIM | Transmit "good" frame interrupt mask bit after more than 1 collision.<br>0: Do not mask the interrupt that occurs when ETH_MMCTXINT.TXMCOLGFIS is 1.<br>1: Mask the interrupt that occurs when ETH_MMCTXINT.TXMCOLGFIS is 1. |
| 14        | TXSCOLGFIM | Transmit "good" frame interrupt mask bit after only 1 collision.<br>0: Do not mask the interrupt that occurs when ETH_MMCTXINT.TXSCOLGFIS is 1.<br>1: Mask the interrupt that occurs when ETH_MMCTXINT.TXSCOLGFIS is 1.      |
| 13:0      | Reserved   | Reserved, the reset value must be maintained.  |

### 25.5.27 ETH MMC transmitted "good" frame counter register after 1 collision (ETH\_MMCTXGFASCCNT)

Address offset: 0x014C

Reset value: 0x0000 0000

This register is used to count the number of frames successfully transmitted after only one collision in half-duplex mode.

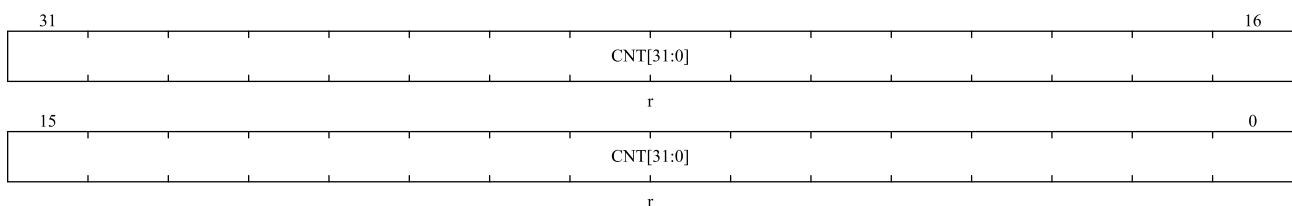

| Bit field | Name      | Description  |
|-----------|-----------|--|
| 31:0      | CNT[31:0] | Transmitted "good" frame counter after 1 collision.<br>These bits are a counter of "good" frame transmitted after 1 collision. |

### 25.5.28 ETH MMC transmitted “good” frame counter register after more than 1 collision (ETH\_MMCTXGFAMSCCNT)

Address offset: 0x0150

Reset value: 0x0000 0000

This register is used to count the number of frames successfully transmitted after more than one collision in half-duplex mode.

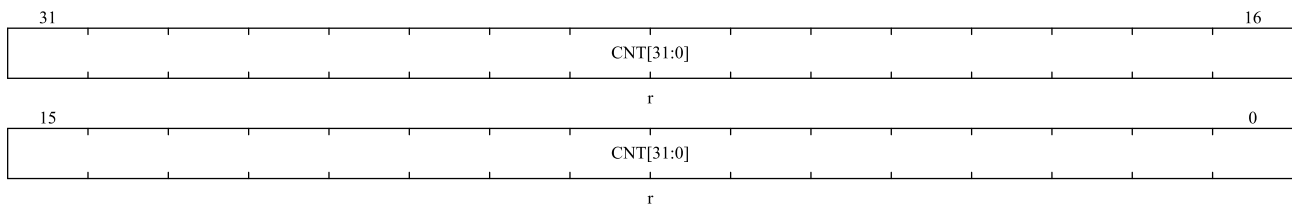

| Bit field | Name      | Description  |
|-----------|-----------|--|
| 31:0      | CNT[31:0] | Transmitted "good" frame counter after more than 1 collision.<br>These bits are a counter of "good" frame transmitted after more than 1 collision. |

### 25.5.29 ETH MMC transmitted “good” frame counter register (ETH\_MMCTXGFCNT)

Address offset: 0x0168

Reset value: 0x0000 0000

This register is used to count the number of "good" frames transmitted.

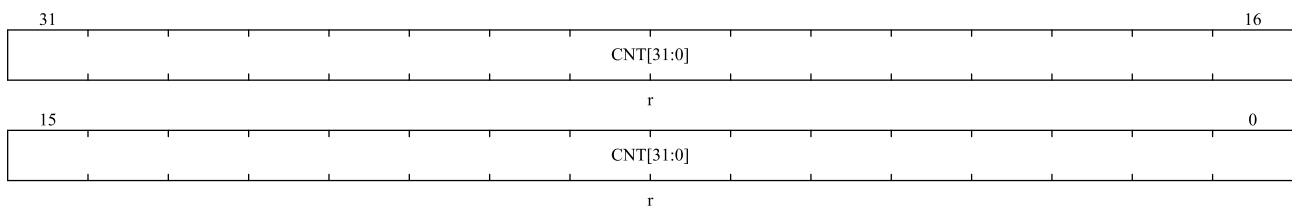

| Bit field | Name      | Description  |
|-----------|-----------|--|
| 31:0      | CNT[31:0] | Transmitted "good" frame counter.<br>These bits are a counter of "good" frame transmitted. |

### 25.5.30 ETH MMC CRC error received frame counter register

#### (ETH\_MMCRXFCECNT)

Address offset: 0x0194

Reset value: 0x0000 0000

This register is used to count the number of frames with CRC errors in the received frames.

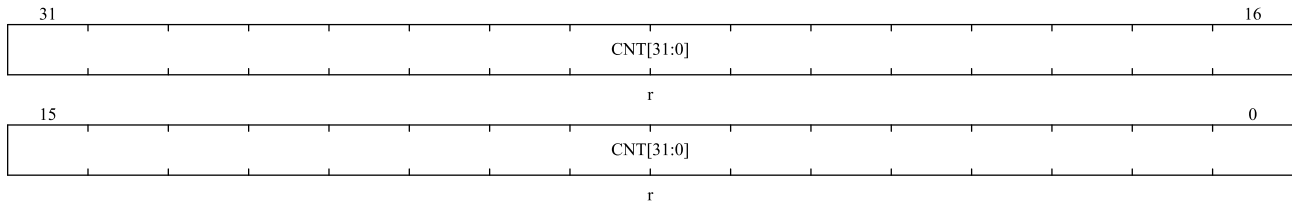

| Bit field | Name      | Description  |
|-----------|-----------|--|
| 31:0      | CNT[31:0] | CRC error received frame counter.<br>These bits are a counter of frames with CRC errors in the received frame. |

### 25.5.31 ETH MMC alignment error received frame counter register

#### (ETH\_MMCRXFAECNT)

Address offset: 0x0198

Reset value: 0x0000 0000

This register is used to count the number of frames with alignment errors in received frames.

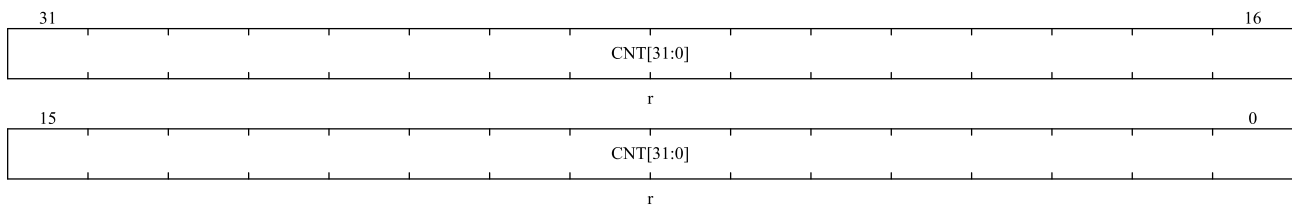

| Bit field | Name      | Description  |
|-----------|-----------|--|
| 31:0      | CNT[31:0] | Alignment error received frame counter.<br>These bits are a counter of frames with misalignment in the received frame. |

### 25.5.32 ETH MMC receive "good" unicast frame counter register

#### (ETH\_MMCRXGUF CNT)

Address offset: 0x01C4

Reset value: 0x0000 0000

This register is used to count the number of "good" unicast frames received.

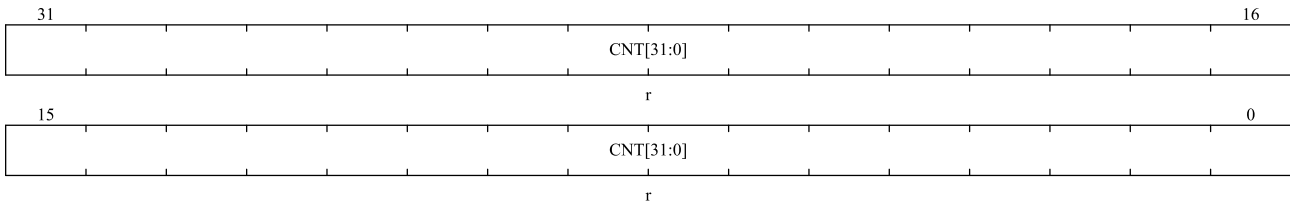

| Bit field | Name      | Description  |
|-----------|-----------|--|
| 31:0      | CNT[31:0] | "Good" unicast frame receive counter.<br>These bits are a counter of "good" unicast frames received. |

### 25.5.33 ETH PTP timestamp control register (ETH\_PTPTSCTRL)

Address offset: 0x0700

Reset value: 0x0000 0000

This register controls the timestamp generation and update logic.

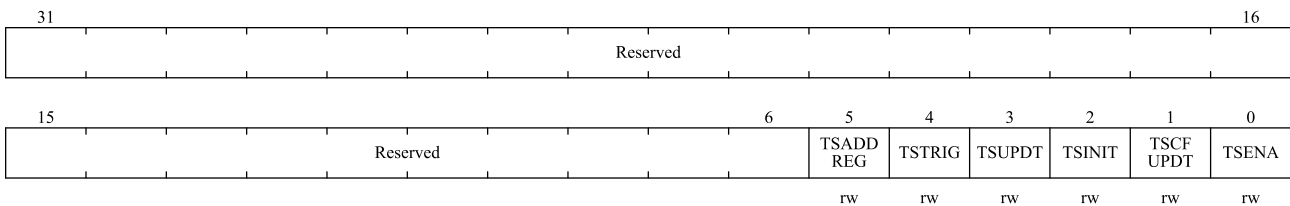

| Bit field | Name     | Description   |
|-----------|----------|---|
| 31:6      | Reserved | Reserved, the reset value must be maintained.   |
| 5         | TSADDREG | Timestamp adder register update bit.<br>This bit is cleared to 0 after the update is complete. This bit must be read as 0 before being set to 1.<br>0: Do not update the value of the timestamp addend register to the PTP module for fine adjustment.<br>1: Update the value of the timestamp addend register to the PTP module for fine adjustment. |
| 4         | TSTRIG   | Timestamp interrupt trigger enable bit.<br>0: Disable time stamp interrupt.<br>1: Enable time stamp interrupt, which will generate an interrupt when the system time exceeds the expected time register value.<br><i>Note: This bit will be cleared to 0 after the timestamp interrupt is generated.</i>  |
| 3         | TSUPDT   | Timestamp system time update bit.<br>Before setting this bit, must ensure that both this bit and ETH_PTPTSCTRL.TSINIT read 0.<br>0: System time remains unchanged.<br>1: Update system time, add or subtract the value of the timestamp high and low update registers to the original system time, and the hardware will clear this bit after         |

| Bit field | Name     | Description   |
|-----------|----------|---|
|           |          | the update is completed.  |
| 2         | TSINIT   | Timestamp system time initialization bit.<br>Before setting this bit, must ensure that this bit read 0.<br>0: System time remains unchanged.<br>1: Initialize system time and replace the original system time with the values of the timestamp high and low update registers. Hardware will clear this bit after initialization is complete. |
| 1         | TSCFUPDT | Timestamp coarse adjustment or fine adjustment update bit.<br>0: Update system timestamp with coarse adjustment.<br>1: Update system timestamp with fine adjustment.  |
| 0         | TSENA    | Timestamp enable bit.<br>0: Disable timestamp function.<br>1: Enable timestamp function of received and transmitted frames.<br><i>Note: The system time needs to be re-initialized every time this bit is set to '1'.</i>   |

### 25.5.34 ETH PTP subsecond increment register (ETH\_PTPSSINC)

Address offset: 0x0704

Reset value: 0x0000 0000

This register is used to configure the 8-bit increment value of the subsecond increment register. In coarse adjustment mode, the system time is incremented by the value of this register after every HCLK clock cycle. In fine adjustment mode, the system time is incremented by the value of this register only when the accumulator overflows.

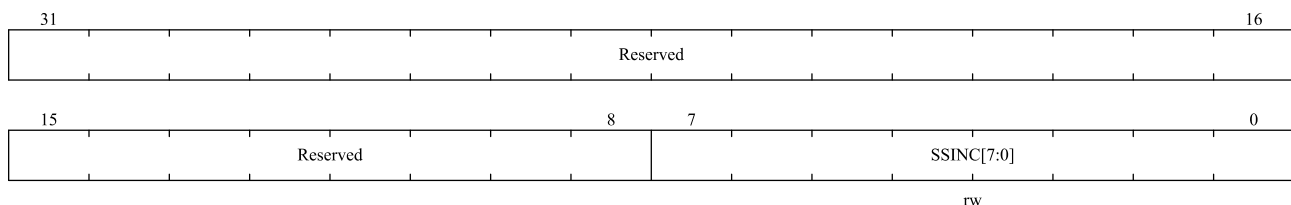

| Bit field | Name       | Description  |
|-----------|------------|--|
| 31:8      | Reserved   | Reserved, the reset value must be maintained.  |
| 7:0       | SSINC[7:0] | System time subsecond increment value.<br>The value of these bits is added to the subsecond value of the system time each time the system time is incremented. |

### 25.5.35 ETH PTP timestamp high register (ETH\_PTPSEC)

Address offset: 0x0708

Reset value: 0x0000 0000

This register is read-only and contains the second value of the system time. The system time high and low 2 registers contain the current system time value of the MAC, which is continuously updated.

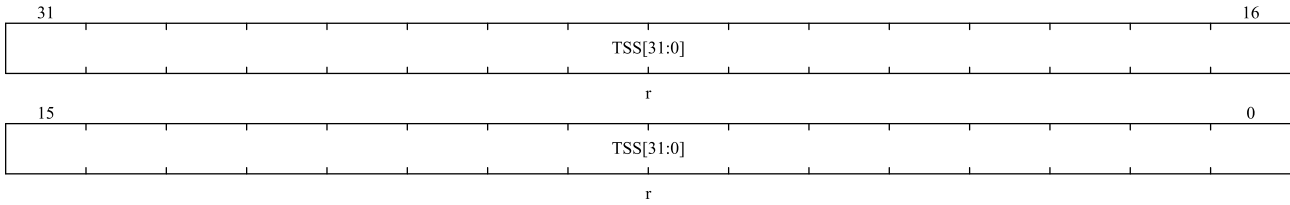

| Bit field | Name      | Description   |
|-----------|-----------|---|
| 31:0      | TSS[31:0] | System time seconds.<br>These bits represent the second value of the MAC's current system time. |

### 25.5.36 ETH PTP timestamp low register (ETH\_PTPNS)

Address offset: 0x070C

Reset value: 0x0000 0000

This register is read-only and contains the subsecond value of the system time.

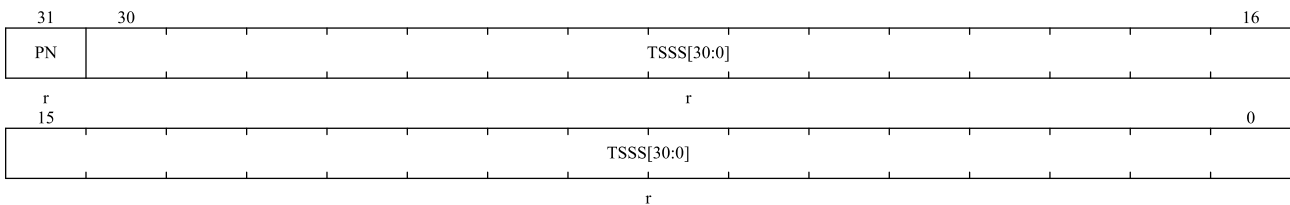

| Bit field | Name       | Description   |
|-----------|------------|---|
| 31        | PN         | System time positive or negative sign.<br>0: Time value is positive value.<br>1: Time value is negative value.                  |
| 30:0      | TSSS[30:0] | System time subsecond.<br>These bits represent the sub-second value of the current system time, sub-second precision is 0.46ns. |

### 25.5.37 ETH PTP timestamp high update register (ETH\_PTPSECUP)

Address offset: 0x0710

Reset value: 0x0000 0000

Use the value of this register to replace, add or subtract the current system time. The timestamp high update register and the timestamp low update register can be used to initialize or update the current system time of the MAC. These 2 registers should be written first, and then ETH\_PTPTSCTRL.TSINIT or ETH\_PTPTSCTRL.TSUPDT should be set.

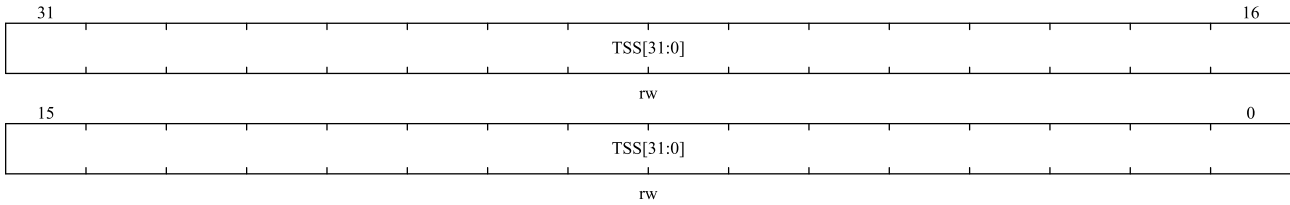

| Bit field | Name      | Description  |
|-----------|-----------|--|
| 31:0      | TSS[31:0] | Timestamp seconds update value.<br>The value represented by these bits is used to replace the system time when initialized, and when updated, it represents the value of seconds added or subtracted from the system time. |

### 25.5.38 ETH PTP timestamp low update register (ETH\_PTPNSUP)

Address offset: 0x0714

Reset value: 0x0000 0000

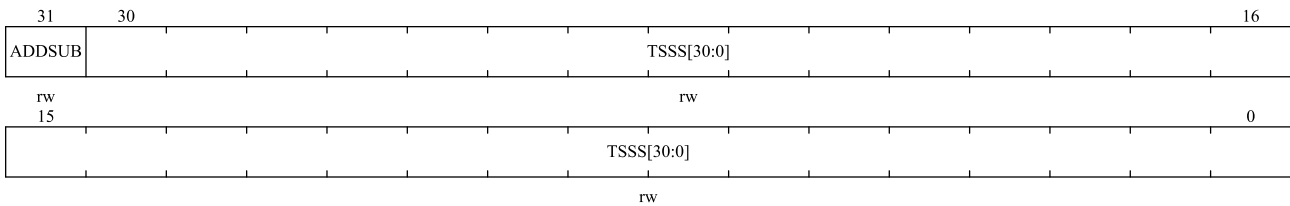

| Bit field | Name       | Description   |
|-----------|------------|---|
| 31        | ADDSUB     | Timestamp update positive or negative sign.<br>When ETH_PTPTCTRL.TSINIT is set to 1, this bit should be 0.<br>When ETH_PTPTCTRL.TSUPDT is set to 1 and this bit is 0, the timestamp update value is added to the system time, otherwise, the timestamp update value is subtracted from the system time.<br>0: Time value is positive value.<br>1: Time value is negative value. |
| 30:0      | TSSS[30:0] | System time subsecond.<br>These bits represent the sub-second value of the current system time, sub-second precision is 0.46ns.   |

### 25.5.39 ETH PTP timestamp addend register (ETH\_PTPTSADD)

Address offset: 0x0718

Reset value: 0x0000 0000

This register is only used when the system time update mode is fine adjustment mode. Software can use this register to linearly calibrate the clock frequency to the main clock. The value of this register is accumulated to the 32-bit accumulator every clock cycle, and the system time is updated once the accumulator overflows.

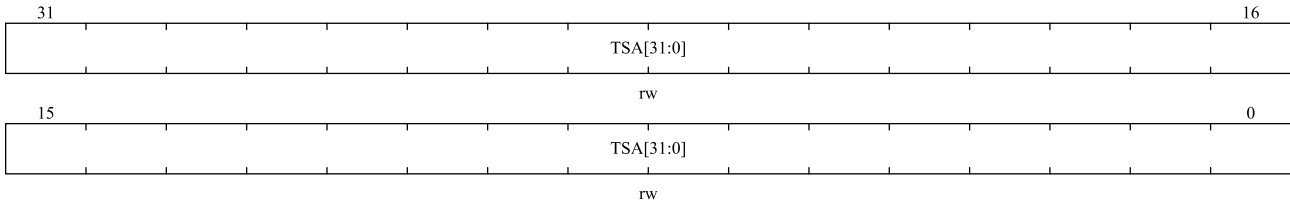

| Bit field | Name      | Description   |
|-----------|-----------|---|
| 31:0      | TSA[31:0] | Timestamp addend.<br>These bits represent the 32-bit value added to the accumulator when the clocks are synchronized. |

### 25.5.40 ETH PTP target time high register (ETH\_PTPTTSEC)

Address offset: 0x071C

Reset value: 0x0000 0000

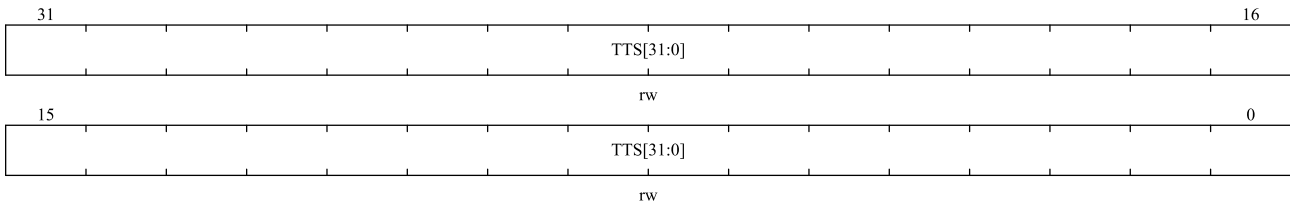

| Bit field | Name      | Description  |
|-----------|-----------|--|
| 31:0      | TTS[31:0] | Target timestamp high.<br>These bits represent the seconds value of the target time. If the timestamp value equals or exceeds the target time, and the corresponding interrupt is enabled, MAC will generate an interrupt. |

### 25.5.41 ETH PTP target time low register (ETH\_PTPTTNS)

Address offset: 0x0720

Reset value: 0x0000 0000

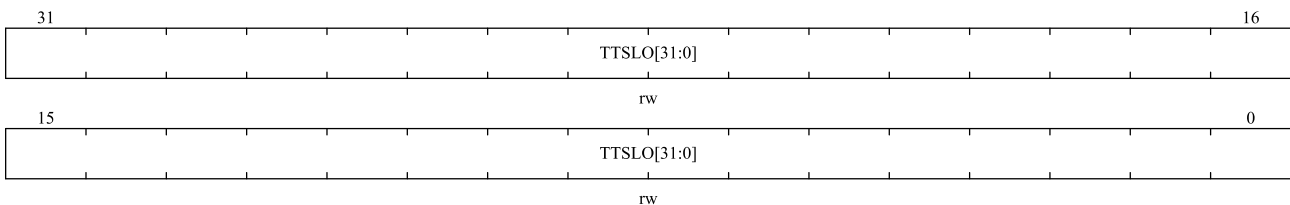

| Bit field | Name        | Description  |
|-----------|-------------|--|
| 31:0      | TTSLO[31:0] | Target timestamp low.<br>These bits represent the nanosecond value of the target time. If the timestamp value equals or exceeds the target time, and the corresponding interrupt is enabled, MAC will generate an interrupt. |

## 25.5.42 ETH DMA bus mode register (ETH\_DMABUSMOD)

Address offset: 0x1000

Reset value: 0x0000 2101

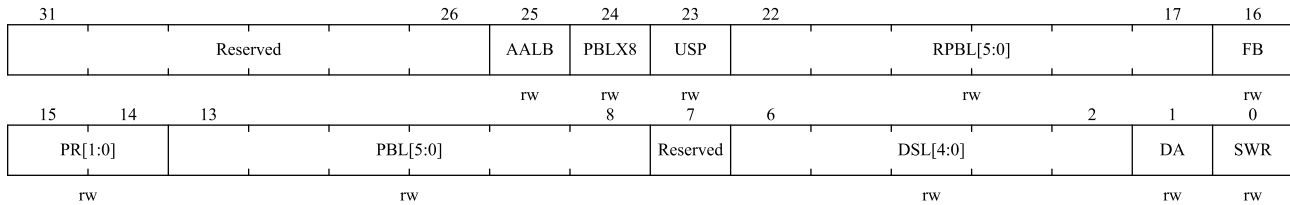

| Bit field | Name      | Description  |
|-----------|-----------|--|
| 31:26     | Reserved  | Reserved, the reset value must be maintained.  |
| 25        | AALB      | Address alignment.<br>0: Disable the transfer address alignment function.<br>1: Enable transfer address alignment, if ETH_DMABUSMOD.FB is 1, the AHB interface aligns all LS bits of consecutive transfers to the starting address. If ETH_DMABUSMOD.FB is 0, except the address of the first AHB access (the starting address of accessing the data buffer) is not aligned, subsequent transfers and addresses are aligned.   |
| 24        | PBLX8     | 8x PBL mode.<br>0: The PBL value is used as the DMA transfer length value.<br>1: The PBL value is multiplied by 8 as the DMA transfer length value.<br>For specific values, see ETH_DMABUSMOD.RPBL[5:0] or ETH_DMABUSMOD.PBL[5:0].   |
| 23        | USP       | Use dispersed PBL.<br>0: The PBL value set by ETH_DMABUSMOD.PBL[5:0] is valid for both DMA receive and transmit controllers.<br>1: The value of ETH_DMABUSMOD.RPBL[5:0] is used as the PBL value of receiving DMA, and the value of ETH_DMABUSMOD.PBL[5:0] is only used as the PBL value of sending DMA.   |
| 22:17     | RPBL[5:0] | RxDMA PBL.<br>If ETH_DMABUSMOD.USP = 0, these bits have no effect. When ETH_DMABUSMOD.USP = 1, these bits define the maximum number of data transfers for one DMA forwarding.<br>000001: The maximum number of data transfers is 1<br>000010: The maximum number of data transfers is 2<br>000100: The maximum number of data transfers is 4<br>001000: The maximum number of data transfers is 8<br>010000: The maximum number of data transfers is 16<br>100000: The maximum number of data transfers is 32<br>Other: reserved |
| 16        | FB        | Fixed burst bit.   |

| Bit field | Name     | Description  |
|-----------|----------|--|
|           |          | <p>This bit controls whether the AHB master interface performs fixed burst length transfers.</p> <p>0: AHB uses only SINGLE and INCR data transfer operations during continuous transfer.</p> <p>1: AHB uses SINGLE, INCR4, INCR8 and INCR16 data transfer operations during continuous transfer.</p>  |
| 15:14     | PR[1:0]  | <p>Receive and transmit priority ratio.</p> <p>These bits represent the access priority ratio between RxDMA and TxDMA.</p> <p>00: RxDMA:TxDMA = 1:1</p> <p>01: RxDMA:TxDMA = 2:1</p> <p>10: RxDMA:TxDMA = 3:1</p> <p>11: RxDMA:TxDMA = 4:1</p> <p><i>Note: This bit is only valid when the DMA arbitration mode is cyclic mode (ETH_DMABUSMOD.DA = 0).</i></p>   |
| 13:8      | PBL[5:0] | <p>Programmable burst length.</p> <p>These bits define the maximum number of data transfers for one DMA transfer. If ETH_DMABUSMOD.USP = 1, these bits are only used for TxDMA transfers. If ETH_DMABUSMOD.USP = 0, these bits are used for both TxDMA and RxDMA transfers.</p> <p>000001: The maximum number of data transfers is 1</p> <p>000010: The maximum number of data transfers is 2</p> <p>000100: The maximum number of data transfers is 4</p> <p>001000: The maximum number of data transfers is 8</p> <p>010000: The maximum number of data transfers is 16</p> <p>100000: The maximum number of data transfers is 32</p> <p>Other: reserved</p> |
| 7         | Reserved | Reserved, the reset value must be maintained.  |
| 6:2       | DSL[4:0] | <p>Descriptor skip length.</p> <p>These bits define the jump distance between 2 descriptors connected in a ring structure, in words (32 bits). Address jump refers to the address difference from the end of the current descriptor to the beginning of the next descriptor.</p>   |
| 1         | DA       | <p>DMA arbitration bit.</p> <p>This bit indicates the arbitration mode between TxDMA and RxDMA.</p> <p>0: Arbitrate in a round-robin manner according to the value of these bits in ETH_DMABUSMOD.PR[1:0].</p> <p>1: Fixed priority mode, the priority of receiving is higher than that of sending.</p>  |
| 0         | SWR      | <p>Software reset.</p> <p>0: No effect</p> <p>1: Reset the internal registers and logic circuits of all subsystems of ETH. After the reset operation of different clock domain modules in the MAC is completed, this bit is automatically cleared.</p> <p><i>Note: Make sure this bit is 0 before writing to any ETH register.</i></p>   |

### 25.5.43 ETH DMA transmit query request register (ETH\_DMATXPD)

Address offset: 0x1004

Reset value: 0x0000 0000

This register is used for TxDMA to query the list of transmit descriptors. TxDMA usually enters the pending state due to a data underflow error in the transmit frame or the descriptor is occupied by the CPU (TDES0.OWN = 0). Any value can be written to this register to enable sending queries.

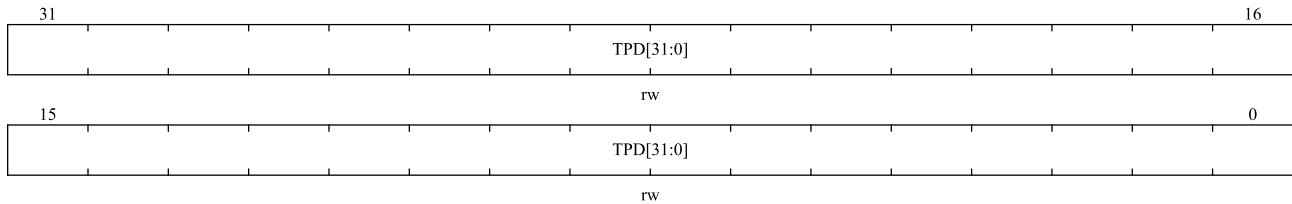

| Bit field | Name      | Description   |
|-----------|-----------|---|
| 31:0      | TPD[31:0] | Transmit query request bit.<br>Write any value to these bits to enable TxDMA transmit query, which will query whether the current descriptor (descriptor address is in the ETH_DMACHTXDESC register) is occupied by the CPU. If not (TDES0.OWN = 1), the descriptor is available and TxDMA exits the suspend state and resumes work. On the contrary (TDES0.OWN = 0), the TxDMA returns to the suspended state and ETH_DMASTS.TU is set to 1. |

### 25.5.44 ETH DMA receive query request register (ETH\_DMARXPD)

Address offset: 0x1008

Reset value: 0x0000 0000

This register is used for RxDMA query of the receive descriptor list. Writing any value to this register enables the receive query.

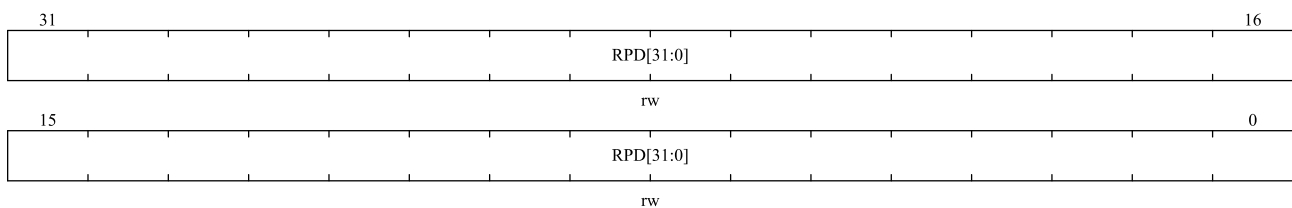

| Bit field | Name      | Description   |
|-----------|-----------|---|
| 31:0      | RPD[31:0] | Receive query request bit.<br>Write any value to these bits to enable RxDMA receive query, which will query whether the current descriptor (descriptor address is in the ETH_DMACHRXDESC register) is occupied by the CPU. If not (RDES0.OWN = 1), the descriptor is available and RxDMA exits the suspend state and resumes work. On the contrary (RDES0.OWN = 0), the RxDMA returns to the suspended state and ETH_DMASTS.RU is set to 1. |

## 25.5.45 ETH DMA receive descriptor list address register

### (ETH\_DMARXDLADDR)

Address offset: 0x100C

Reset value: 0x0000 0000

The receive descriptor list register points to the beginning of the receive descriptor queue. Descriptor queues are located in physical memory, and their addresses must be word-aligned. Writing to this register is only allowed when reception is stopped. This register must be configured correctly before starting the RxDMA receive process.

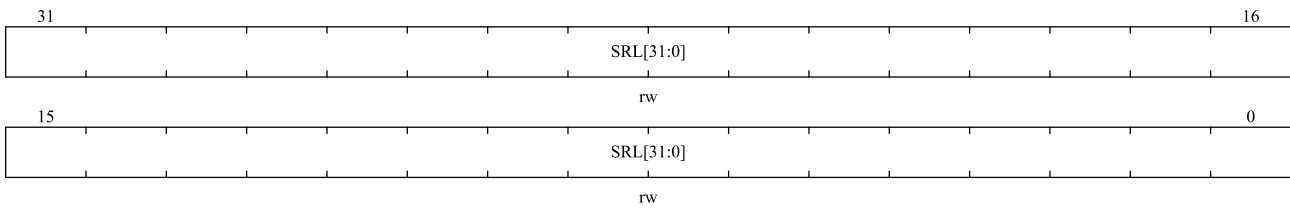

| Bit field | Name      | Description  |
|-----------|-----------|--|
| 31:0      | SRL[31:0] | Receive queue base address.<br>These bits contain the address of the first descriptor in the receive descriptor queue.<br>RxDMA ignores the lowest 2 bits and defaults to 0. |

## 25.5.46 ETH DMA transmit descriptor list address register

### (ETH\_DMATXDLADDR)

Address offset: 0x1010

Reset value: 0x0000 0000

This register points to the start of the transmit descriptor queue. Descriptor queues are located in physical memory, and their addresses must be word-aligned. Writing to this register is only allowed when transmission is stopped. Before starting the TxDMA transmission process, this register must be configured correctly.

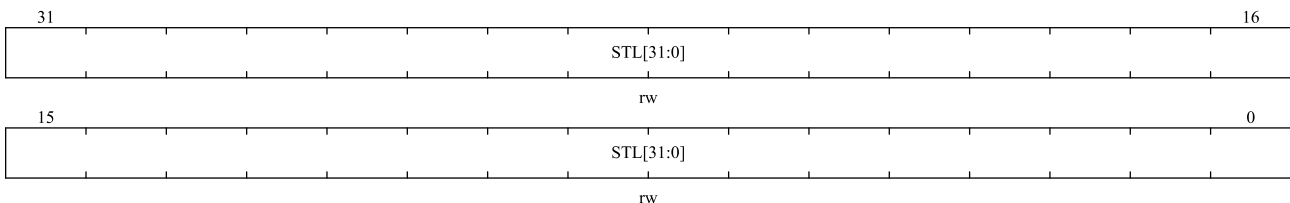

| Bit field | Name      | Description  |
|-----------|-----------|--|
| 31:0      | STL[31:0] | Transmit queue base address.<br>These bits contain the address of the first descriptor of the transmit descriptor queue.<br>TxDMA ignores the lowest 2 bits and defaults to 0. |

## 25.5.47 ETH DMA status register (ETH\_DMASTS)

Address offset: 0x1014

Reset value: 0x0000 0000

This register contains all the status bits that the DMA feeds back to the application. Software usually reads this register in an interrupt service routine or during polling. Most bits in this register can trigger interrupts. Reading this register does not clear the flags in it. Writing 1 to bit0~bit16 (except reserved bits) can clear them, while writing 0 is invalid. By setting the corresponding bits in the ETH\_DMAINTEN register, the interrupts triggered by these bits (except reserved bits) of bit0~bit16 can be masked.

|          |       |         |          |         |          |         |        |          |       |          |       |       |        |       |            |
|----------|-------|---------|----------|---------|----------|---------|--------|----------|-------|----------|-------|-------|--------|-------|------------|
| 31       | 30    | 29      | 28       | 27      | 26       | 25      | 23     | 22       | 20    | 19       | 17    | 16    |        |       |            |
| Reserved |       | TTI     | PMTI     | MMCI    | Reserved | EB[2:0] |        | TPS[2:0] |       | RPS[2:0] |       | NIS   |        |       |            |
| 15       | 14    | r<br>13 | r<br>12  | r<br>11 | 10       | 9       | r<br>8 | 7        | 6     | r<br>5   | 4     | 3     | r<br>2 | 1     | re_wl<br>0 |
| AIS      | ERI   | FBI     | Reserved |         | ETI      | RWT     | RPSS   | RU       | RI    | UNF      | OVF   | TJT   | TU     | TPSS  | TI         |
| rc_wl    | rc_wl | rc_wl   |          |         | rc_wl    | rc_wl   | rc_wl  | rc_wl    | rc_wl | rc_wl    | rc_wl | rc_wl | rc_wl  | rc_wl | rc_wl      |

| Bit field | Name     | Description  |
|-----------|----------|--|
| 31:30     | Reserved | Reserved, the reset value must be maintained.  |
| 29        | TTI      | Timestamp trigger status.<br>This bit indicates that a timestamp interrupt event has occurred. Clear this bit by clearing ETH_MACINTSTS.TSTS. When this bit is set to 1, an interrupt is generated if the corresponding interrupt is enabled.<br>0: No timestamp interrupt event occurred.<br>1: A timestamp interrupt event has occurred.   |
| 28        | PMTI     | PMT status.<br>This bit indicates that an interrupt event has occurred in the PMT module of the MAC controller. Software must read the corresponding register of the MAC controller, find the source of the interrupt and clear it, in order to clear this bit. When this bit is set, an interrupt is generated if the corresponding interrupt is enabled.<br>0: No PMT interrupt event occurred.<br>1: A PMT interrupt event has occurred.  |
| 27        | MMCI     | MMC status.<br>This bit indicates that an interrupt event has occurred in the MMC module of the MAC controller. Software must read the corresponding register of the MAC controller, find the source of the interrupt and clear it, in order to clear this bit. When this bit is set, an interrupt is generated if the corresponding interrupt is enabled.<br>0: No MMC interrupt event occurred.<br>1: An MMC interrupt event has occurred. |
| 26        | Reserved | Reserved, the reset value must be maintained.  |
| 25:23     | EB[2:0]  | Error bit status.<br>When ETH_DMASTS.FBI = 1, these bits will do error type resolution for bus response errors on the AHB bus, these bits will not trigger an interrupt.<br>EB[0]:   |

| Bit field | Name     | Description  |
|-----------|----------|--|
|           |          | 0: Error during RxDMA transfer of data.<br>1: Error during TxDMA transfer of data.<br>EB[1]:<br>0: Error during write transfer.<br>1: Error during read transfer.<br>EB[2]:<br>0: Error during data buffer access.<br>1: Error during descriptor access.   |
| 22:20     | TPS[2:0] | Transmit process status.<br>These bits indicate the status of TxDMA.<br>000: Stop, receive reset or stop transmitting command.<br>001: Running, getting transmit descriptor.<br>010: Running, waiting status information.<br>011: Running, data in memory is being read and stored in TxFIFO.<br>100, 101: Reserved.<br>110: Pause, transmit descriptor unavailable or transmit buffer data underflow.<br>111: Running, closing transmit descriptor.   |
| 19:17     | RPS[2:0] | Receive process status.<br>These bits indicate the status of RxDMA.<br>000: Stop, receive reset or stop receiving command.<br>001: Running, getting receive descriptor.<br>010: Reserved.<br>011: Running, waiting receive packets.<br>100: Pause, receive descriptor not available.<br>101: Running, closing receive descriptor.<br>110: Reserved.<br>111: Running, forwarding received packets from RxFIFO to memory.  |
| 16        | NIS      | Normal interrupt summary.<br>With the corresponding interrupt enabled in the ETH_DMAINTEN register, the normal interrupt summary bits are the logical OR of the following bit values: <ul style="list-style-type: none"> <li>■ ETH_DMASTS [0]: Transmit interrupt</li> <li>■ ETH_DMASTS [2]: Transmit buffer unavailable</li> <li>■ ETH_DMASTS [6]: Receive interrupt</li> <li>■ ETH_DMASTS [14]: Early receive interrupt</li> </ul> Only unmasked interrupts will affect this bit.<br>The value of this bit is bound to the above bits. After it is set to 1, this bit can only be cleared to 0 by clearing the bit that caused the bit to 1 (write 1). |
| 15        | AIS      | Abnormal interrupt summary.<br>With the corresponding interrupt enabled in the ETH_DMAINTEN register, the exception interrupt summary bit is the logical OR of the following bit values: <ul style="list-style-type: none"> <li>■ ETH_DMASTS [1]: Transmit process stopped</li> <li>■ ETH_DMASTS [3]: Transmit Jabber timeout</li> <li>■ ETH_DMASTS [4]: RxFIFO overflow</li> </ul>  |

| Bit field | Name     | Description  |
|-----------|----------|--|
|           |          | <ul style="list-style-type: none"> <li>■ ETH_DMASTS [5]: Transmit data underflow</li> <li>■ ETH_DMASTS [7]: Receive buffer unavailable</li> <li>■ ETH_DMASTS [8]: Receive process stopped</li> <li>■ ETH_DMASTS [9]: Receive watchdog timeout</li> <li>■ ETH_DMASTS [10]: Early send interrupt</li> <li>■ ETH_DMASTS [13]: Bus fatal error</li> </ul> <p>Only unmasked interrupts will affect this bit.</p> <p>The value of this bit is bound to the above bits. After it is set to 1, this bit can only be cleared to 0 by clearing the bit that caused the bit to 1 (write 1).</p> |
| 14        | ERI      | <p>Early receive status.</p> <p>This bit is automatically cleared to 0 when ETH_DMASTS.RI is set to 1.</p> <p>0: Frame data is not received.</p> <p>1: The received data frame has filled the first buffer by DMA.</p>   |
| 13        | FBI      | <p>Bus fatal error status.</p> <p>This bit indicates that an AHB interface response error has occurred, the type of error can be explained by these bits of ETH_DMASTS.EB[2:0].</p> <p>0: No bus error occurred.</p> <p>1: A bus error has occurred and the corresponding DMA controller closes all bus accesses.</p>  |
| 12:11     | Reserved | Reserved, the reset value must be maintained.  |
| 10        | ETI      | <p>Early transmit status.</p> <p>0: Transmit frame has not been fully transferred into TxFIFO.</p> <p>1: Transmit frame has been completely transferred into TxFIFO.</p>   |
| 9         | RWT      | <p>Receive watchdog timeout status.</p> <p>0: Received frame length less than 2048 bytes.</p> <p>1: Received frame length exceeds 2048 bytes.</p>  |
| 8         | RPSS     | <p>Receive process stop status.</p> <p>0: Receive process no stop.</p> <p>1: Receive process enters stop status.</p>   |
| 7         | RU       | <p>Receive buffer unavailable status.</p> <p>When this bit is set to 1, it means that the next receive descriptor is not occupied by RxDMA, and RxDMA will enter the pause (suspend) state. In this case, it is necessary to reconfigure the ownership of the descriptor and initiate the receive query request command to exit the pause (suspend) state. Refer to the description of relevant steps in Section 25.4.8.4.5.</p> <p>0: RDES0.OWN of the next receive descriptor is 1.</p> <p>1: RDES0.OWN of the next receive descriptor is 0.</p>                                   |
| 6         | RI       | <p>Receive status.</p> <p>0: Frame receive not complete.</p> <p>1: Frame receive complete.</p>   |
| 5         | UNF      | <p>Transmit data underflow status.</p> <p>When this bit is set, the transmission enters the pause (suspend) state and set TDES0.UF to 1.</p>   |

| Bit field | Name | Description  |
|-----------|------|--|
|           |      | 0: No transmit data underflow error occurred.<br>1: Data underflow error occurred during frame transmission.   |
| 4         | OVF  | Receive overflow status.<br>When this bit is 1, if some frame data has been forwarded to the memory, set RDES0.OE to 1.<br>0: No receive data overflow error occurred.<br>1: Data overflow error occurred during frame receive.  |
| 3         | TJT  | Transmit Jabber timeout status.<br>When this bit is 1, the sending process is aborted and enters the stop state, and TDES0.JT is set to 1 at the same time.<br>0: No transmit Jabber timer timeout event occurred.<br>1: Transmit Jabber timer timeout.  |
| 2         | TU   | Transmit buffer unavailable status.<br>When this bit is 1, it means that the next transmit descriptor is not occupied by TxDMA, and TxDMA will enter the pause (suspend) state. In this case, it is necessary to reconfigure the ownership of the descriptor and initiate a query request command to exit the pause (suspend) state. Refer to the description of relevant steps in Section 25.4.8.3.5.<br>0: TDES0.OWN of the next transmit descriptor is 1.<br>1: TDES0.OWN of the next transmit descriptor is 0. |
| 1         | TPSS | Transmit process stop status<br>0: Transmit process no stop.<br>1: Transmit process enters stop state.   |
| 0         | TI   | Transmit status.<br>When this bit is set to 1, TDES0.OWN of the first descriptor is also set to 1.<br>0: Frame transmission has not yet been completed.<br>1: Frame transmission has been completed.   |

### 25.5.48 ETH DMA operation mode register (ETH\_DMAOPMOD)

Address offset: 0x1018

Reset value: 0x0000 0000

This register sets the working mode and command for receiving and sending. This register should be written last in the entire DMA initialization process.

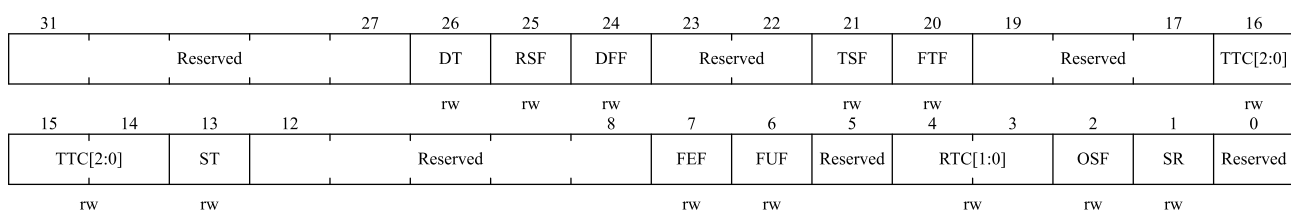

| Bit field | Name     | Description                                   |
|-----------|----------|---|
| 31:27     | Reserved | Reserved, the reset value must be maintained. |

|       |          |  |
|-------|----------|--|
| 26    | DT       | <p>Do not drop TCP/IP checksum error frames.</p> <p>0: If ETH_DMAOPMOD.FEF is 0, MAC discards all erroneous frames.</p> <p>1: If the received frame has only checksum errors, MAC will not discard the frame.</p>  |
| 25    | RSF      | <p>Receive store-and-forward.</p> <p>0: RxFIFO works in cut-through (threshold) mode, and the forwarding threshold is determined by these bits of ETH_DMAOPMOD.RTC[1:0].</p> <p>1: RxFIFO works in store-and-forward mode. Only after the frame is completely written to RxFIFO, RxDMA will forward it to the application, and the value of ETH_DMAOPMOD.RTC will be ignored.</p>  |
| 24    | DFP      | <p>Do not clear received frames.</p> <p>0: When the receive descriptor is not available (or the receive buffer is not available), the RxDMA empties the receive frame in the RxFIFO.</p> <p>1: RxDMA does not clear receive frames, even if receive descriptors are not available (or receive buffers are not available).</p>  |
| 23:22 | Reserved | Reserved, the reset value must be maintained.  |
| 21    | TSF      | <p>Transmit store-and-forward.</p> <p>0: TxFIFO works in cut-through (threshold) mode, and the transmit threshold is determined by these bits of ETH_DMAOPMOD.TTC[2:0].</p> <p>1: TxFIFO works in store-and-forward mode. Only after the frame is completely written to TxFIFO, MAC will transmit it out. At this time, the value of ETH_DMAOPMOD.TTC will be ignored.</p> <p><i>Note: This bit can only be modified when the transmission is stopped.</i></p> |
| 20    | FTF      | <p>Clear TxFIFO.</p> <p>When this bit is set to 1, TxFIFO control logic is reset to its initial state, so that all data in the TxFIFO is emptied/lost. This bit is automatically cleared to 0 after the clear operation is complete. Writing to this register is not allowed until this bit is 0.</p>  |
| 19:17 | Reserved | Reserved, the reset value must be maintained.  |
| 16:14 | TTC[2:0] | <p>Transmit threshold control.</p> <p>These bits control the threshold of TxFIFO in cut-through (threshold) mode. These bits are ignored when ETH_DMAOPMOD.TSF = 1.</p> <p>000: 64<br/>         001: 128<br/>         010: 192<br/>         011: 256<br/>         100: 40<br/>         101: 32<br/>         110: 24<br/>         111: 16</p>   |
| 13    | ST       | <p>Start/stop transmission.</p> <p>0: After the current frame is transmit or TxDMA enters the pause (suspend) state, the transmit process enters stop mode. Holds the position of the next transmit descriptor in the transmit descriptor queue, which becomes the current descriptor when the transfer resumes.</p> <p>1: Transmit process enters running state. TxDMA obtains the current transmit</p>   |

|      |          |   |
|------|----------|---|
|      |          | <p>descriptor, and the transmit frame descriptor can be obtained from the ETH_DMATXDLADDR base address. If the last transmission was stopped, it can also be obtained from the pointer position of the transmit descriptor queue. If the TDES0.OWN of the current descriptor is 0, the TxDMA enters suspend (suspended) state and sets ETH_DMASTS.TU to 1.</p> <p><i>Note: Unpredictable consequences may occur if this bit is set before other DMA registers have been set.</i></p>  |
| 12:8 | Reserved | Reserved, the reset value must be maintained.   |
| 7    | FEF      | <p>Forward error frames.</p> <p>0: When RxFIFO is operating in cut-through (threshold) mode, if a framing error (CRC error, collision error, checksum error, watchdog timeout, overflow) is detected before forwarding the RxFIFO data to memory, RxFIFO will discard this wrong frame. But if a frame error is detected after the RxFIFO data has been forwarded to memory, the frame will not be discarded. When RxFIFO works in store-and-forward mode, once a frame error is detected during reception, the frame will be discarded.</p> <p>1: All frames except too short frames are forwarded to DMA.</p> |
| 6    | FUF      | <p>Forward "good" frames of insufficient length.</p> <p>0: RxFIFO discards all frames less than 64 bytes in length, but will forward frames if they start to be forwarded to the application before too short frames are detected (e.g. in cut-through (threshold) mode, frame length is less than the receive threshold) whole frame.</p> <p>1: RxFIFO forwards "good" frames with insufficient length (frame length less than 64 bytes but no errors) to the application.</p>   |
| 5    | Reserved | Reserved, the reset value must be maintained.   |
| 4:3  | RTC[1:0] | <p>Receive threshold control.</p> <p>These bits control the threshold of the RxFIFO in cut-through (threshold) mode.</p> <p>00: 64<br/>01: 32<br/>10: 96<br/>11: 128</p> <p><i>Note: These bits are only valid when ETH_DMAOPMOD.RSF is 0.</i></p>  |
| 2    | OSF      | <p>Operation second frame.</p> <p>0: TxDMA starts to transmit the data of the next frame only after receiving the transmission status information of the previous frame.</p> <p>1: TxDMA starts to transmit the data of the next frame after the data of the previous frame is all stored in the Tx FIFO and before receiving the transmission status information of the previous frame.</p>  |
| 1    | SR       | <p>Start/stop receive.</p> <p>0: RxDMA enters stop mode after forwarding the current received frame. Holds the position of the next receive descriptor in the receive descriptor queue, which becomes the current descriptor when the transfer resumes. "Stop receive" can only be done while reception is running or when reception is paused.</p> <p>1: Put the receiving process into the running state, and the DMA checks the current position of the receiving descriptor queue to process the next received frame. The</p>   |

|   |          |   |
|---|----------|---|
|   |          | receiving frame descriptor can be obtained from the base address of ETH_DMARXDLADDR, or from the pointer position of the receiving descriptor queue if the last receiving was stopped. If the RDES0.OWN of the current descriptor is 0, then the receiving process enters the suspended (suspended) state and sets the ETH_DMASTS.RU bit to 1. The "Start receive" command is valid only when reception is stopped or when reception is paused.<br><i>Note: Unpredictable consequences may occur if the "Start Receive" command is issued before all other DMA registers have been set.</i> |
| 0 | Reserved | Reserved, the reset value must be maintained.   |

### 25.5.49 ETH DMA interrupt enable register (ETH\_DMAINTEN)

Address offset: 0x101C

Reset value: 0x0000 0000

For Ethernet interrupts, the interrupt will only occur if ETH\_DMASTS.TTI or ETH\_DMASTS.PMTI is 1 and the corresponding interrupt is not masked, or if ETH\_DMASTS.NIS or ETH\_DMASTS.AIS is set to 1 and the corresponding interrupt is enabled.

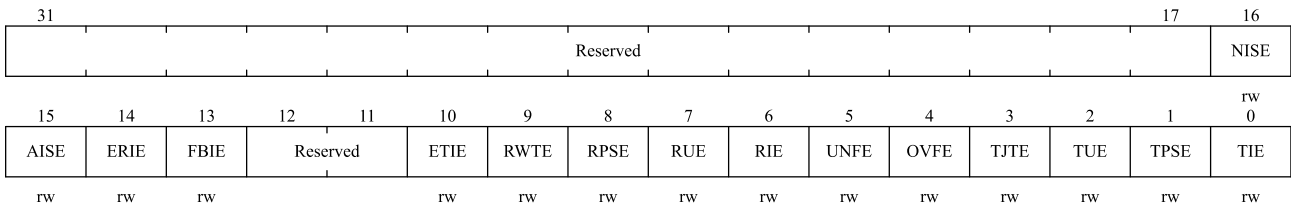

| Bit field | Name     | Description   |
|-----------|----------|---|
| 31:17     | Reserved | Reserved, the reset value must be maintained.   |
| 16        | NISE     | Normal interrupt summary enabled.<br>0: Mask normal interrupt.<br>1: Enable normal interrupt.<br>This bit enables the following bits: <ul style="list-style-type: none"> <li>■ ETH_DMASTS[0]: Transmit interrupt</li> <li>■ ETH_DMASTS[2]: Transmit buffer unavailable</li> <li>■ ETH_DMASTS[6]: Receive interrupt</li> <li>■ ETH_DMASTS[14]: Early receive interrupt</li> </ul>  |
| 15        | AISE     | Abort summary enable.<br>0: Mask abnormal interrupt.<br>1: Enable exception interrupt.<br>This bit enables the following bits: <ul style="list-style-type: none"> <li>■ ETH_DMASTS[1]: Transmit process stop</li> <li>■ ETH_DMASTS[3]: Transmit Jabber timeout</li> <li>■ ETH_DMASTS[4]: Receive overflow</li> <li>■ ETH_DMASTS[5]: Transmit underflow</li> <li>■ ETH_DMASTS[7]: Receive buffer unavailable</li> <li>■ ETH_DMASTS[8]: Receive process stop</li> </ul> |

| Bit field | Name     | Description  |
|-----------|----------|--|
|           |          | <ul style="list-style-type: none"> <li>■ ETH_DMASTS[9]: Receive watchdog timeout</li> <li>■ ETH_DMASTS[10]: Early transmit interrupt</li> <li>■ ETH_DMASTS[13]: Bus fatal error</li> </ul> |
| 14        | ERIE     | Early receive interrupt enable.<br>0: Mask early receive interrupt.<br>1: When ETH_DMAINTEN.NISE is 1, enable early receive interrupt.   |
| 13        | FBIE     | Bus fatal error interrupt enable.<br>0: Mask bus fatal error interrupt.<br>1: When ETH_DMAINTEN.AISE is 1, enable bus fatal error interrupt.   |
| 12:11     | Reserved | Reserved, the reset value must be maintained.  |
| 10        | ETIE     | Early transmit interrupt enable.<br>0: Mask early transmit interrupt.<br>1: When ETH_DMAINTEN.AISE is 1, enable early transmit interrupt.  |
| 9         | RWTE     | Receive watchdog timeout interrupt enable.<br>0: Mask receive watchdog timeout interrupt.<br>1: When ETH_DMAINTEN.AISE is 1, enable receive watchdog timeout interrupt.                    |
| 8         | RPSE     | Receive process stop interrupt enable.<br>0: Mask receive process stop interrupt.<br>1: When ETH_DMAINTEN.AISE is 1, enable receive process stop interrupt.                                |
| 7         | RUE      | Receive buffer unavailable interrupt enable.<br>0: Mask receive buffer unavailable interrupt.<br>1: When ETH_DMAINTEN.AISE is 1, enable receive buffer unavailable interrupt.              |
| 6         | RIE      | Receive interrupt enable.<br>0: Mask receive interrupt.<br>1: When ETH_DMAINTEN.NISE is 1, enable receive interrupt.   |
| 5         | UNFE     | Transmit underflow interrupt enable.<br>0: Mask transmit underflow interrupt.<br>1: When ETH_DMAINTEN.AISE is 1, enable transmit underflow interrupt.                                      |
| 4         | OVFE     | Receive overflow interrupt enable.<br>0: Mask receive overflow interrupt.<br>1: When ETH_DMAINTEN.AISE is 1, enable receive overflow interrupt.  |
| 3         | TJTE     | Transmit Jabber timeout interrupt enable.<br>0: Mask transmit Jabber timeout interrupt.<br>1: When ETH_DMAINTEN.AISE is 1, enable transmit Jabber timeout interrupt.                       |
| 2         | TUE      | Transmit buffer unavailable interrupt enable.<br>0: Mask transmit buffer unavailable interrupt.<br>1: When ETH_DMAINTEN.NISE is 1, enable transmit buffer unavailable interrupt.           |
| 1         | TPSE     | Transmit process stop interrupt enable<br>0: Mask transmit process to stop the interrupt.<br>1: When ETH_DMAINTEN.AISE is 1, enable transmit process stop interrupt.                       |
| 0         | TIE      | Transmit interrupt enable.<br>0: Mask transmit interrupt.<br>1: When ETH_DMAINTEN.NISE is 1, enable transmit interrupt.  |

## 25.5.50 ETH DMA missed frames and buffer overflow counter register

### (ETH\_DMAMFBOCNT)

Address offset: 0x1020

Reset value: 0x0000 0000

Ethernet DMA has 2 counters to count the number of frames lost during reception. The current value of the counter can be obtained by reading this register. This counter is often used for troubleshooting.

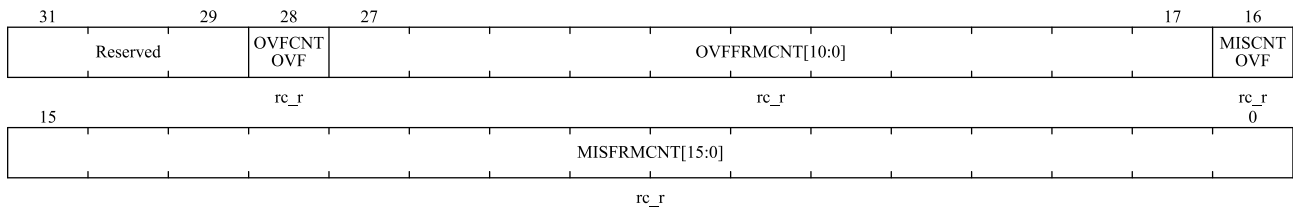

| Bit field | Name            | Description  |
|-----------|-----------------|--|
| 31:29     | Reserved        | Reserved, the reset value must be maintained.  |
| 28        | OVFCNTOVF       | FIFO overflow counter overflow bit.  |
| 27:17     | OVFFRMCNT[10:0] | Frames missed by application.<br>These bits indicate the number of frames missed by the RxFIFO.  |
| 16        | MISCNTOVF       | Missed frame counter overflow bit.   |
| 15:0      | MISFRMCNT[15:0] | Frames missed by controller.<br>These bits indicate the number of frames missed by RxDMA due to the unavailability of the MCU's receive buffer. This counter is incremented by 1 each time the DMA clears an incoming frame. |

## 25.5.51 ETH DMA current transmit descriptor address register

### (ETH\_DMACHTXDESC)

Address offset: 0x1048

Reset value: 0x0000 0000

This register points to the start address (base address) of the transmit descriptor that TxDMA is reading.

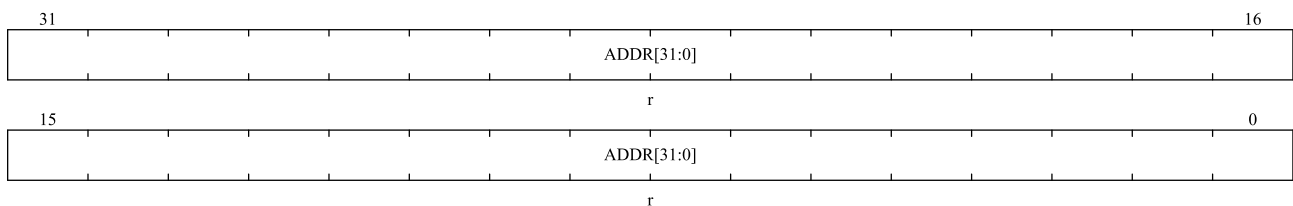

| Bit field | Name       | Description   |
|-----------|------------|---|
| 31:0      | ADDR[31:0] | Transmit descriptor address pointer.<br>These bits are cleared on reset and are automatically updated by TxDMA during |

| Bit field | Name | Description |
|-----------|------|-------------|
|           |      | operation.  |

### 25.5.52 ETH DMA current receive descriptor address register

#### (ETH\_DMACHRXDESC)

Address offset: 0x104C

Reset value: 0x0000 0000

This register points to the start address (base address) of the receive descriptor that RxDMA is reading.

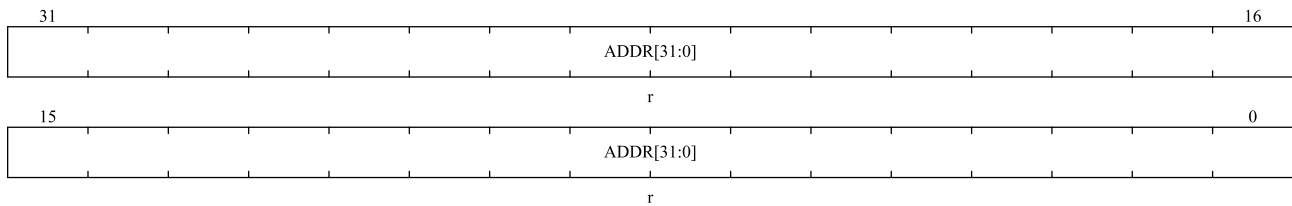

| Bit field | Name       | Description   |
|-----------|------------|---|
| 31:0      | ADDR[31:0] | Receive descriptor address pointer.<br>These bits are cleared on reset and are automatically updated by RxDMA during operation. |

### 25.5.53 ETH DMA current transmit buffer address register

#### (ETH\_DMACHTXBADDR)

Address offset: 0x1050

Reset value: 0x0000 0000

This register points to the address of the transmit buffer that TxDMA is reading.

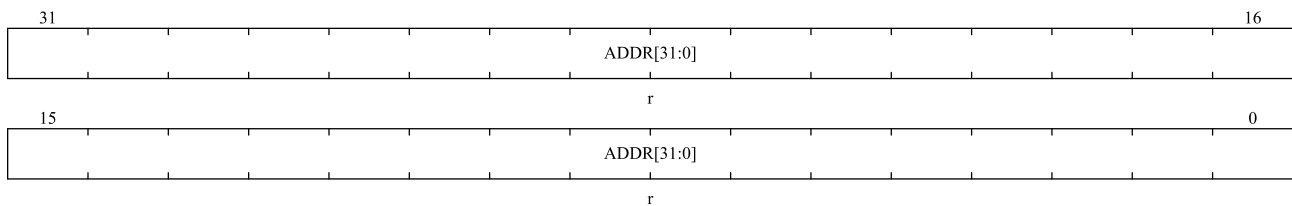

| Bit field | Name       | Description  |
|-----------|------------|--|
| 31:0      | ADDR[31:0] | Transmit buffer address pointer.<br>These bits are cleared on reset and updated by TxDMA during operation. |

## 25.5.54 ETH DMA current receive buffer address register

### (ETH\_DMACHRXBADDR)

Address offset: 0x1054

Reset value: 0x0000 0000

This register points to the address of the receive buffer that RxDMA is reading.

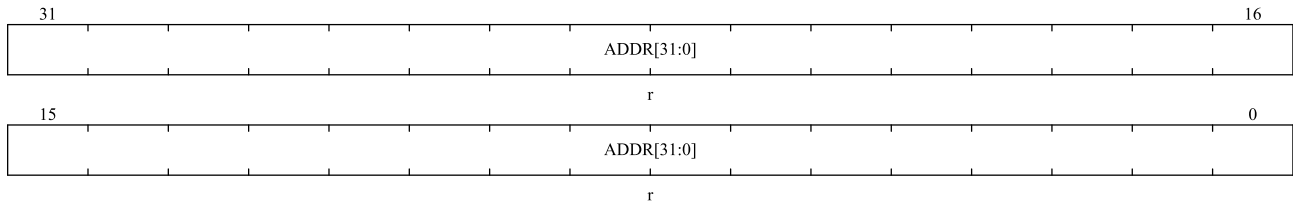

| Bit field | Name       | Description   |
|-----------|------------|---|
| 31:0      | ADDR[31:0] | Receive buffer address pointer.<br>These bits are cleared on reset and updated by RxDMA during operation. |

## 26 Comparator (COMP)

The COMP module is used to compare the analog voltages of two inputs and output high/low levels based on the comparison results. When "INP" input voltage is higher than "INM" input voltage, the comparator output is high level, when "INP" input voltage is lower than "INM" input voltage, the comparator output is low level.

### 26.1 COMP system connection block diagram

The COMP module supports a maximum of seven independent comparators, which are connected to the APB1 bus..

Figure 26-1 Comparator1 and comparator2 connection diagram

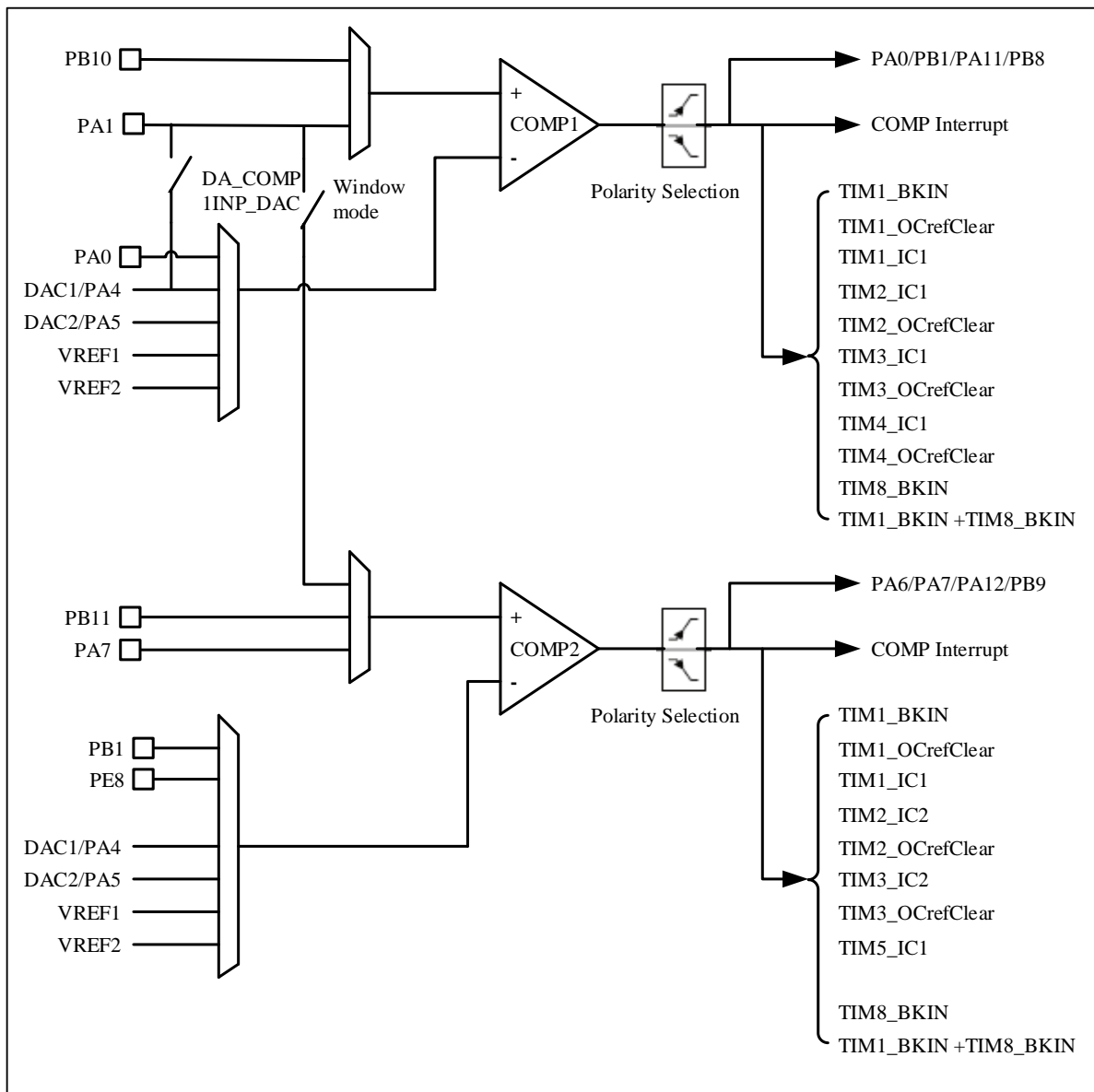

Figure 26-2 Comparator3 and comparator4 connection diagram

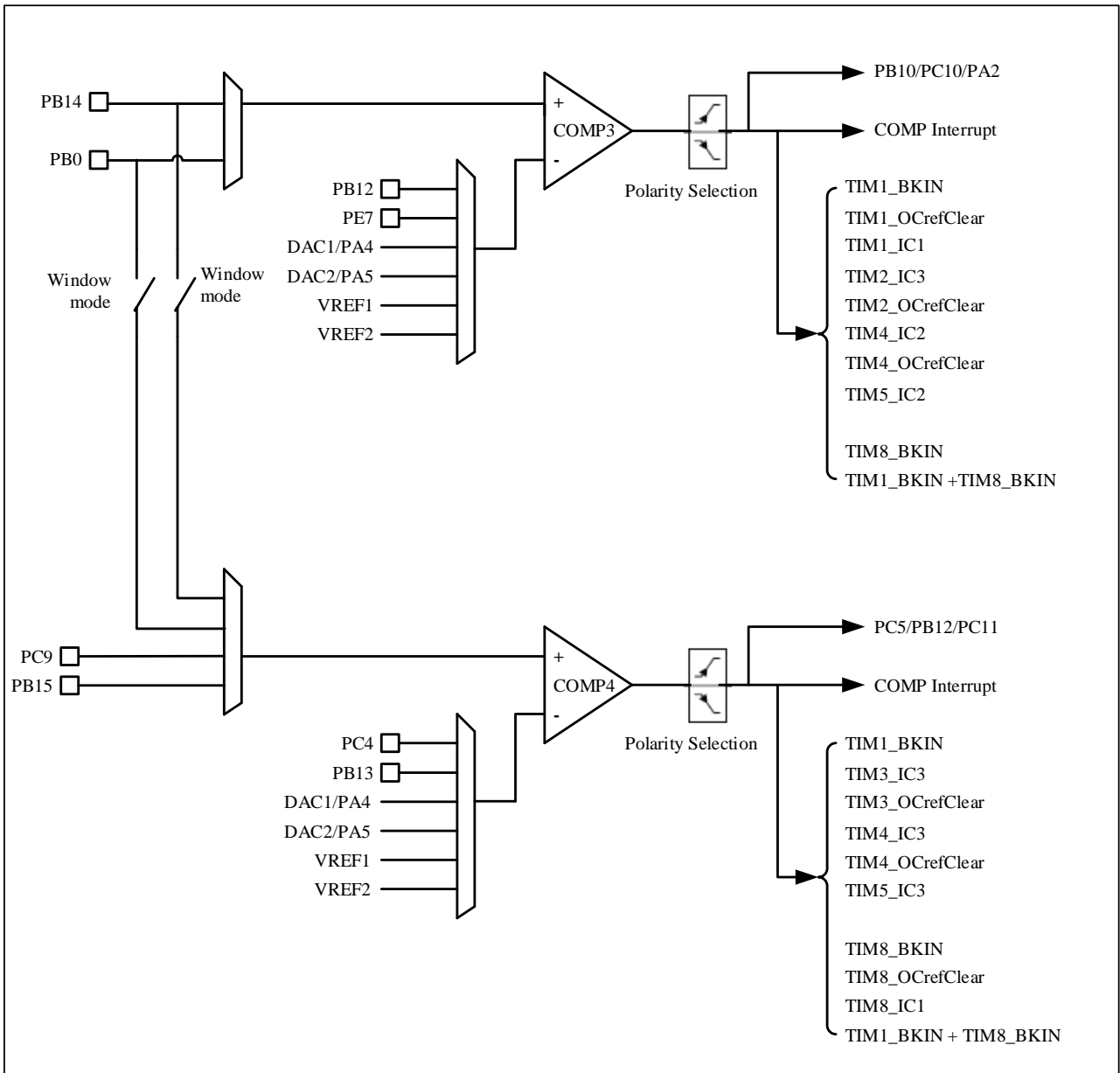
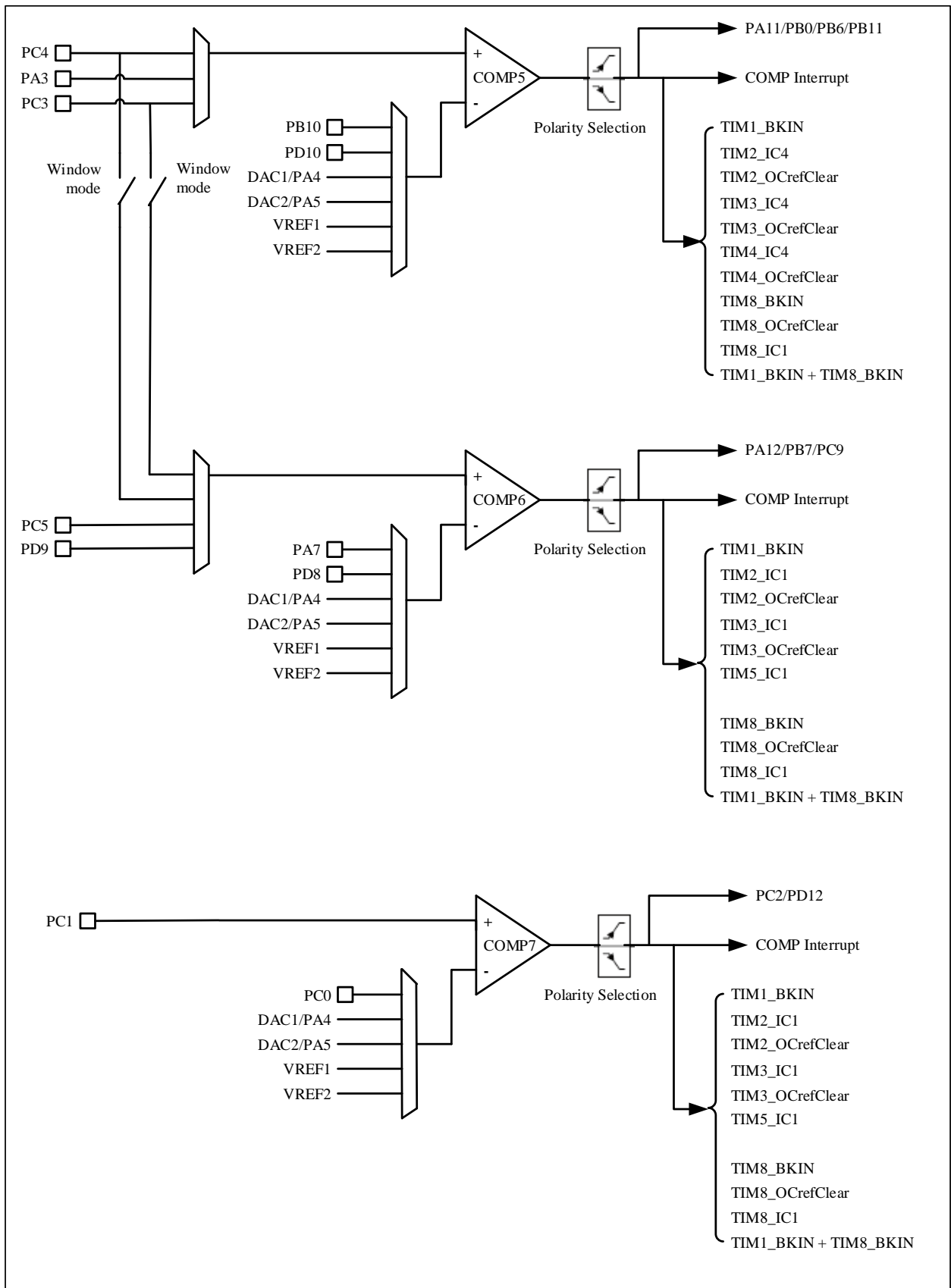

Figure 26-3 Comparator5,Comparator6,comparator7 connection diagram



## 26.2 Main features

- Up to 7 independent comparators.
- Built-in two 64 level programmable comparison voltage reference sources VREF1, VREF2.
- Support filter clock, filter reset.
- Output polarity can be configured high and low.
- Hysteresis The value can be none, low, medium, or high.
- The comparison result can be output to the I/O port or trigger timer, which is used to capture events, OCREF\_CLR events, brake events, and generate interrupts.
- Input channels can check I/O ports, channel outputs of DAC, VREF1, VREF2.
- It can be read - only or read - write, and can be unlocked only after a reset.
- Blanking support, Blanking source can be configured to produce Blanking.
- COMP1/COMP2, COMP3/COMP4, COMP5/COMP6 can form window comparators.
- You can wake the system from Sleep mode or STOP0 mode by generating an interrupt.
- Filter window size can be configured.
- Filter threshold size can be configured.
- The sampling frequency for filtering can be configured.

## 26.3 COMP configuration process

Complete configuration items are as follows. If the default configuration is used, skip the corresponding configuration items.

1. Configurable hysteresis level COMP<sub>x</sub>\_CTRL.HYST[1:0]
2. Configure the output polarity COMP<sub>x</sub>\_CTRL.POL
3. Configuration input selection, comparator non-inverting input COMP<sub>x</sub>\_CTRL.INPSEL[3:0], inverting input COMP<sub>x</sub>\_CTRL.INMSEL [2:0]
4. Select COMP<sub>x</sub>\_CTRL.OUTSEL[3:0]for configuration output
5. Configure the blanking source COMP<sub>x</sub>\_CTRL.BLKING[2:0]
6. Configure the comparator window mode COMP\_WINMODE. CMP12MD
7. Configure the filter sampling window COMP<sub>x</sub>\_FILC.SAMPW[4:0]
8. Configure the threshold COMP<sub>x</sub>\_FILC.THRESH[4:0] (threshold should be greater than COMP<sub>x</sub>\_FILC.SAMPW[4:0]/2)
9. Configure the filter sampling frequency (for timer applications, sampling frequency should be greater than 5MHz)
10. Enable COMP<sub>x</sub>\_FILC.FILEN filter

## 11. Enable COMPx\_CTRL.EN on the comparator

*Note: For the above steps, the filter should be enabled first and then the comparator should be enabled. The comparator should be enabled after the filtering (if enabled) is configured and enabled. In addition, when the comparator control register is locked, the LOCK can be cancelled only through reset.*

## 26.4 COMP working mode

### 26.4.1 Window mode

The comparators can be combined into 3 window comparators as follows:

- Comparator 1 and comparator 2 share PA1 to form window comparators.
- Comparator 3 and comparator 4 share PB14 or PB0 to form window comparators.
- Comparator 5 and comparator 6 share PC3 or PC4 to form window comparators.

### 26.4.2 Independent comparator

The seven comparators can be configured independently to complete the comparator function. The output of a comparator can be output to an I/O port. Each comparator has a different remapped port. You can configure the comparator register COMPx\_CTRL.OUTSEL[3:0] to enable the corresponding feature pin at the output.

Comparator output, support trigger events, such as can be configured as timer 1, timer 8 brake function.

*Note: Refer to the comparator interconnection for specific configuration*

## 26.5 Comparator interconnection

For the interconnection of the output port of the comparator, please refer to the AFIO register chapter, which defines the value of the remapping of the comparator OUT.

| OUT | COMP1[1:0] | COMP2[3:2] | COMP3[5:4] | COMP4[7:6] | COMP5[9:8] | COMP6[11:10] | COMP7[12] |
|-----|------------|------------|------------|------------|------------|--------------|-----------|
| 00  | PA0        | PA6        | PB10       | PC5        | PB0        | PC9          | PC2       |
| 01  | PB1        | PA7        | PC10       | PB12       | PB11       | PA12         | PD12      |
| 10  | PA11       | PA12       | Not Used   | Not Used   | PB6        | Not Used     | --        |
| 11  | PB8        | PB9        | PA2        | PC11       | PA11       | PB7          | --        |

*Note:*

1. COMP7 has only 1 bit to control output remapping.
2. After COMP1, COMP2, COMP5, and COMP7 are enabled, the IO ports corresponding to COMP1\_OUT, COMP2\_OUT, COMP5\_OUT, and COMP7\_OUT cannot be configured as the output mode of other peripherals, but can be the input mode of other peripherals, GPIO input, GPIO output.

The comparator INP pin has the following configuration.

| INPSEL | COMP1 | COMP2 | COMP3 | COMP4 | COMP5 | COMP6 | COMP7 |
|--------|-------|-------|-------|-------|-------|-------|-------|
| 000    | PA1   | PA1   | PB14  | PB14  | PC4   | PC4   | PC1   |
| 001    | PB10  | PB11  | PB0   | PB0   | PC3   | PC3   | --    |

|       |    |     |    |      |     |     |    |
|-------|----|-----|----|------|-----|-----|----|
| 010   | -- | PA7 | -- | PC9  | PA3 | PC5 | -- |
| 011   | -- | --  | -- | PB15 | --  | PD9 | -- |
| 100   | -- | --  | -- | --   | --  | --  | -- |
| Other | -- | --  | -- | --   | --  | --  | -- |

The comparator INM pins have the following configuration.

| INMSEL | COMP1    | COMP2    | COMP3    | COMP4    | COMP5    | COMP6    | COMP7    |
|--------|----------|----------|----------|----------|----------|----------|----------|
| 000    | PA0      | PB1      | PB12     | PC4      | PB10     | PA7      | PC0      |
| 001    | DAC1/PA4 | PE8      | PE7      | PB13     | PD10     | PD8      | DAC1/PA4 |
| 010    | DAC2/PA5 | DAC1/PA4 | DAC1/PA4 | DAC1/PA4 | DAC1/PA4 | DAC1/PA4 | DAC2/PA5 |
| 011    | VREF1    | DAC2/PA5 | DAC2/PA5 | DAC2/PA5 | DAC2/PA5 | DAC2/PA5 | VREF1    |
| 100    | VREF2    | VREF1    | VREF1    | VREF1    | VREF1    | VREF1    | VREF2    |
| 101    | --       | VREF2    | VREF2    | VREF2    | VREF2    | VREF2    | --       |
| Other  | --       | --       | --       | --       | --       | --       | --       |

Comparator output TRIG signal has the following interconnection.

| TRIG  | COMP1                 | COMP2                 | COMP3                 | COMP4                 | COMP5                 | COMP6                 | COMP7                 |
|-------|-----------------------|-----------------------|-----------------------|-----------------------|-----------------------|-----------------------|-----------------------|
| 0000  | NC                    | NC                    | NC                    | NC                    | NC                    | NC                    | NC                    |
| 0001  | TIM1_BKIN             | TIM1_BKIN             | TIM1_BKIN             | TIM1_BKIN             | TIM1_BKIN             | TIM1_BKIN             | TIM1_BKIN             |
| 0010  | TIM1_IC1              | TIM1_IC1              | TIM1_IC1              | TIM3_IC3              | TIM2_IC4              | TIM2_IC1              | TIM2_IC1              |
| 0011  | TIM1_OCrefclear       | TIM1_OCrefclear       | TIM1_OCrefclear       | TIM3_OCrefclear       | TIM2_OCrefclear       | TIM2_OCrefclear       | TIM2_OCrefclear       |
| 0100  | TIM2_IC1              | TIM2_IC2              | TIM2_IC3              | TIM4_IC3              | TIM3_IC4              | TIM3_IC1              | TIM3_IC1              |
| 0101  | TIM2_OCrefclear       | TIM2_OCrefclear       | TIM2_OCrefclear       | TIM4_OCrefclear       | TIM3_OCrefclear       | TIM3_OCrefclear       | TIM3_OCrefclear       |
| 0110  | TIM3_IC1              | TIM3_IC2              | TIM4_IC2              | TIM5_IC3              | TIM4_IC4              | TIM5_IC1              | TIM5_IC1              |
| 0111  | TIM3_OCrefclear       | TIM3_OCrefclear       | TIM4_OCrefclear       | --                    | TIM4_OCrefclear       | --                    | --                    |
| 1000  | TIM4_IC1              | TIM5_IC1              | TIM5_IC2              | TIM8_IC1              | TIM8_IC1              | TIM8_IC1              | TIM8_IC1              |
| 1001  | TIM4_OCrefclear       | --                    | --                    | TIM8_OCrefclear       | TIM8_OCrefclear       | TIM8_OCrefclear       | TIM8_OCrefclear       |
| 1010  | TIM8_BKIN             | TIM8_BKIN             | TIM8_BKIN             | TIM8_BKIN             | TIM8_BKIN             | TIM8_BKIN             | TIM8_BKIN             |
| 1011  | TIM1_BKIN + TIM8_BKIN | TIM1_BKIN + TIM8_BKIN | TIM1_BKIN + TIM8_BKIN | TIM1_BKIN + TIM8_BKIN | TIM1_BKIN + TIM8_BKIN | TIM1_BKIN + TIM8_BKIN | TIM1_BKIN + TIM8_BKIN |
| Other | --                    | --                    | --                    | --                    | --                    | --                    | --                    |

## 26.6 Interrupt

COMP supports interrupt response, and COMP1, COMP1, COMP2, COMP3 share one interrupt entry, COMP4, COMP5, and COMP6 share one interrupt entry, COMP7 has one interrupt entry exclusively. There are two cases of interrupt generation as follows.

- The polarity of COMPx\_CTRL.POL is not reversed, and the interrupt is enabled. When INPSEL > INMSEL, the comparator interrupt will be generated when COMPx\_CTRL.OUT is set to 1 by hardware.

- The polarity of COMP<sub>x</sub>\_CTRL.POL is reversed, and the interrupt is enabled. When INPSEL < INMSEL, the comparator interrupt is generated when COMP<sub>x</sub>\_CTRL.OUT is set to 1 by hardware.

## 26.7 COMP register

### 26.7.1 COMP register overview

Table 26-1 COMP register overview

| Offset | Register    | 31       | 30 | 29 | 28 | 27 | 26 | 25 | 24 | 23 | 22 | 21 | 20 | 19 | 18           | 17  | 16          | 15 | 14          | 13 | 12  | 11          | 10    | 9 | 8           | 7 | 6           | 5 | 4  | 3 | 2 | 1 | 0 |   |   |   |   |   |   |   |   |   |
|--------|-------------|----------|----|----|----|----|----|----|----|----|----|----|----|----|--------------|-----|-------------|----|-------------|----|-----|-------------|-------|---|-------------|---|-------------|---|----|---|---|---|---|---|---|---|---|---|---|---|---|---|
| 010h   | COMP1_CTRL  | Reserved |    |    |    |    |    |    |    |    |    |    |    |    | INPDAC       | OUT | BLKING[2:0] |    | HYST[1:0]   |    | POL | OUTSEL[3:0] |       |   | INPSEL[2:0] |   | INMSEL[2:0] |   | EN |   |   |   |   |   |   |   |   |   |   |   |   |   |
|        | Reset Value |          |    |    |    |    |    |    |    |    |    |    |    |    | 0            | 0   | 0           | 0  | 0           | 0  | 0   | 0           | 0     | 0 | 0           | 0 | 0           | 0 | 0  | 0 | 0 | 0 | 0 | 0 | 0 | 0 | 0 | 0 | 0 | 0 | 0 |   |
| 014h   | COMP1_FILC  | Reserved |    |    |    |    |    |    |    |    |    |    |    |    | SAMPW[4:0]   |     |             |    | THRESH[4:0] |    |     |             | FILEN |   |             |   |             |   |    |   |   |   |   |   |   |   |   |   |   |   |   |   |
|        | Reset Value |          |    |    |    |    |    |    |    |    |    |    |    |    | 0            | 0   | 0           | 0  | 0           | 0  | 0   | 0           | 0     | 0 | 0           | 0 | 0           | 0 | 0  | 0 | 0 | 0 | 0 | 0 | 0 |   |   |   |   |   |   |   |
| 018h   | COMP1_FILP  | Reserved |    |    |    |    |    |    |    |    |    |    |    |    | CLKPSC[15:0] |     |             |    |             |    |     |             |       |   |             |   |             |   |    |   |   |   |   |   |   |   |   |   |   |   |   |   |
|        | Reset Value |          |    |    |    |    |    |    |    |    |    |    |    |    | 0            | 0   | 0           | 0  | 0           | 0  | 0   | 0           | 0     | 0 | 0           | 0 | 0           | 0 | 0  | 0 | 0 | 0 | 0 | 0 | 0 | 0 | 0 | 0 | 0 | 0 | 0 |   |
| 01Ch   | Reserved    |          |    |    |    |    |    |    |    |    |    |    |    |    |              |     |             |    |             |    |     |             |       |   |             |   |             |   |    |   |   |   |   |   |   |   |   |   |   |   |   |   |
| 020h   | COMP2_CTRL  | Reserved |    |    |    |    |    |    |    |    |    |    |    |    | INPDAC       | OUT | BLKING[2:0] |    | HYST[1:0]   |    | POL | OUTSEL[3:0] |       |   | INPSEL[2:0] |   | INMSEL[2:0] |   | EN |   |   |   |   |   |   |   |   |   |   |   |   |   |
|        | Reset Value |          |    |    |    |    |    |    |    |    |    |    |    |    | 0            | 0   | 0           | 0  | 0           | 0  | 0   | 0           | 0     | 0 | 0           | 0 | 0           | 0 | 0  | 0 | 0 | 0 | 0 | 0 | 0 | 0 | 0 | 0 | 0 | 0 | 0 |   |
| 024h   | COMP2_FILC  | Reserved |    |    |    |    |    |    |    |    |    |    |    |    | SAMPW[4:0]   |     |             |    | THRESH[4:0] |    |     |             | FILEN |   |             |   |             |   |    |   |   |   |   |   |   |   |   |   |   |   |   |   |
|        | Reset Value |          |    |    |    |    |    |    |    |    |    |    |    |    | 0            | 0   | 0           | 0  | 0           | 0  | 0   | 0           | 0     | 0 | 0           | 0 | 0           | 0 | 0  | 0 | 0 | 0 | 0 | 0 | 0 | 0 | 0 | 0 | 0 | 0 | 0 |   |
| 028h   | COMP2_FILP  | Reserved |    |    |    |    |    |    |    |    |    |    |    |    | CLKPSC[15:0] |     |             |    |             |    |     |             |       |   |             |   |             |   |    |   |   |   |   |   |   |   |   |   |   |   |   |   |
|        | Reset Value |          |    |    |    |    |    |    |    |    |    |    |    |    | 0            | 0   | 0           | 0  | 0           | 0  | 0   | 0           | 0     | 0 | 0           | 0 | 0           | 0 | 0  | 0 | 0 | 0 | 0 | 0 | 0 | 0 | 0 | 0 | 0 | 0 | 0 | 0 |
| 02Ch   | Reserved    |          |    |    |    |    |    |    |    |    |    |    |    |    |              |     |             |    |             |    |     |             |       |   |             |   |             |   |    |   |   |   |   |   |   |   |   |   |   |   |   |   |
| 030h   | COMP3_CTRL  | Reserved |    |    |    |    |    |    |    |    |    |    |    |    | INPDAC       | OUT | BLKING[2:0] |    | HYST[1:0]   |    | POL | OUTSEL[3:0] |       |   | INPSEL[2:0] |   | INMSEL[2:0] |   | EN |   |   |   |   |   |   |   |   |   |   |   |   |   |
|        | Reset Value |          |    |    |    |    |    |    |    |    |    |    |    |    | 0            | 0   | 0           | 0  | 0           | 0  | 0   | 0           | 0     | 0 | 0           | 0 | 0           | 0 | 0  | 0 | 0 | 0 | 0 | 0 | 0 | 0 | 0 | 0 | 0 | 0 | 0 |   |
| 034h   | COMP3_FILC  | Reserved |    |    |    |    |    |    |    |    |    |    |    |    | SAMPW[4:0]   |     |             |    | THRESH[4:0] |    |     |             | FILEN |   |             |   |             |   |    |   |   |   |   |   |   |   |   |   |   |   |   |   |
|        | Reset Value |          |    |    |    |    |    |    |    |    |    |    |    |    | 0            | 0   | 0           | 0  | 0           | 0  | 0   | 0           | 0     | 0 | 0           | 0 | 0           | 0 | 0  | 0 | 0 | 0 | 0 | 0 | 0 | 0 | 0 | 0 | 0 | 0 | 0 |   |
| 038h   | COMP3_FILP  | Reserved |    |    |    |    |    |    |    |    |    |    |    |    | CLKPSC[15:0] |     |             |    |             |    |     |             |       |   |             |   |             |   |    |   |   |   |   |   |   |   |   |   |   |   |   |   |
|        | Reset Value |          |    |    |    |    |    |    |    |    |    |    |    |    | 0            | 0   | 0           | 0  | 0           | 0  | 0   | 0           | 0     | 0 | 0           | 0 | 0           | 0 | 0  | 0 | 0 | 0 | 0 | 0 | 0 | 0 | 0 | 0 | 0 | 0 | 0 | 0 |
| 03Ch   | Reserved    |          |    |    |    |    |    |    |    |    |    |    |    |    |              |     |             |    |             |    |     |             |       |   |             |   |             |   |    |   |   |   |   |   |   |   |   |   |   |   |   |   |

| Offset | Register    | 31       | 30 | 29 | 28 | 27 | 26 | 25 | 24 | 23 | 22 | 21 | 20 | 19 | 18           | 17  | 16          | 15 | 14         | 13 | 12  | 11          | 10          | 9 | 8           | 7 | 6           | 5 | 4  | 3 | 2 | 1 | 0 |   |   |   |   |   |   |   |   |   |   |   |
|--------|-------------|----------|----|----|----|----|----|----|----|----|----|----|----|----|--------------|-----|-------------|----|------------|----|-----|-------------|-------------|---|-------------|---|-------------|---|----|---|---|---|---|---|---|---|---|---|---|---|---|---|---|---|
| 040h   | COMP4_CTRL  | Reserved |    |    |    |    |    |    |    |    |    |    |    |    | INPDAC       | OUT | BLKING[2:0] |    | HYST[1:0]  |    | POL | OUTSEL[3:0] |             |   | INPSEL[2:0] |   | INMSEL[2:0] |   | EN |   |   |   |   |   |   |   |   |   |   |   |   |   |   |   |
|        | Reset Value |          |    |    |    |    |    |    |    |    |    |    |    |    | 0            | 0   | 0           | 0  | 0          | 0  | 0   | 0           | 0           | 0 | 0           | 0 | 0           | 0 | 0  | 0 | 0 | 0 | 0 | 0 | 0 | 0 | 0 | 0 | 0 | 0 | 0 | 0 | 0 |   |
| 044h   | COMP4_FILC  | Reserved |    |    |    |    |    |    |    |    |    |    |    |    |              |     |             |    | SAMPW[4:0] |    |     |             | THRESH[4:0] |   |             |   | FILEN       |   |    |   |   |   |   |   |   |   |   |   |   |   |   |   |   |   |
|        | Reset Value |          |    |    |    |    |    |    |    |    |    |    |    |    |              |     |             |    | 0          | 0  | 0   | 0           | 0           | 0 | 0           | 0 | 0           | 0 | 0  | 0 | 0 | 0 | 0 | 0 | 0 | 0 | 0 | 0 | 0 | 0 | 0 |   |   |   |
| 048h   | COMP4_FILP  | Reserved |    |    |    |    |    |    |    |    |    |    |    |    | CLKPSC[15:0] |     |             |    |            |    |     |             |             |   |             |   |             |   |    |   |   |   |   |   |   |   |   |   |   |   |   |   |   |   |
|        | Reset Value |          |    |    |    |    |    |    |    |    |    |    |    |    | 0            | 0   | 0           | 0  | 0          | 0  | 0   | 0           | 0           | 0 | 0           | 0 | 0           | 0 | 0  | 0 | 0 | 0 | 0 | 0 | 0 | 0 | 0 | 0 | 0 | 0 | 0 | 0 | 0 | 0 |
| 04Ch   | Reserved    |          |    |    |    |    |    |    |    |    |    |    |    |    |              |     |             |    |            |    |     |             |             |   |             |   |             |   |    |   |   |   |   |   |   |   |   |   |   |   |   |   |   |   |
| 050h   | COMP5_CTRL  | Reserved |    |    |    |    |    |    |    |    |    |    |    |    | INPDAC       | OUT | BLKING[2:0] |    | HYST[1:0]  |    | POL | OUTSEL[3:0] |             |   | INPSEL[2:0] |   | INMSEL[2:0] |   | EN |   |   |   |   |   |   |   |   |   |   |   |   |   |   |   |
|        | Reset Value |          |    |    |    |    |    |    |    |    |    |    |    |    | 0            | 0   | 0           | 0  | 0          | 0  | 0   | 0           | 0           | 0 | 0           | 0 | 0           | 0 | 0  | 0 | 0 | 0 | 0 | 0 | 0 | 0 | 0 | 0 | 0 | 0 | 0 | 0 | 0 |   |
| 054h   | COMP5_FILC  | Reserved |    |    |    |    |    |    |    |    |    |    |    |    |              |     |             |    | SAMPW[4:0] |    |     |             | THRESH[4:0] |   |             |   | FILEN       |   |    |   |   |   |   |   |   |   |   |   |   |   |   |   |   |   |
|        | Reset Value |          |    |    |    |    |    |    |    |    |    |    |    |    |              |     |             |    | 0          | 0  | 0   | 0           | 0           | 0 | 0           | 0 | 0           | 0 | 0  | 0 | 0 | 0 | 0 | 0 | 0 | 0 | 0 | 0 | 0 | 0 | 0 |   |   |   |
| 058h   | COMP5_FILP  | Reserved |    |    |    |    |    |    |    |    |    |    |    |    | CLKPSC[15:0] |     |             |    |            |    |     |             |             |   |             |   |             |   |    |   |   |   |   |   |   |   |   |   |   |   |   |   |   |   |
|        | Reset Value |          |    |    |    |    |    |    |    |    |    |    |    |    | 0            | 0   | 0           | 0  | 0          | 0  | 0   | 0           | 0           | 0 | 0           | 0 | 0           | 0 | 0  | 0 | 0 | 0 | 0 | 0 | 0 | 0 | 0 | 0 | 0 | 0 | 0 | 0 | 0 | 0 |
| 05Ch   | Reserved    |          |    |    |    |    |    |    |    |    |    |    |    |    |              |     |             |    |            |    |     |             |             |   |             |   |             |   |    |   |   |   |   |   |   |   |   |   |   |   |   |   |   |   |
| 060h   | COMP6_CTRL  | Reserved |    |    |    |    |    |    |    |    |    |    |    |    | INPDAC       | OUT | BLKING[2:0] |    | HYST[1:0]  |    | POL | OUTSEL[3:0] |             |   | INPSEL[2:0] |   | INMSEL[2:0] |   | EN |   |   |   |   |   |   |   |   |   |   |   |   |   |   |   |
|        | Reset Value |          |    |    |    |    |    |    |    |    |    |    |    |    | 0            | 0   | 0           | 0  | 0          | 0  | 0   | 0           | 0           | 0 | 0           | 0 | 0           | 0 | 0  | 0 | 0 | 0 | 0 | 0 | 0 | 0 | 0 | 0 | 0 | 0 | 0 | 0 | 0 | 0 |
| 064h   | COMP6_FILC  | Reserved |    |    |    |    |    |    |    |    |    |    |    |    |              |     |             |    | SAMPW[4:0] |    |     |             | THRESH[4:0] |   |             |   | FILEN       |   |    |   |   |   |   |   |   |   |   |   |   |   |   |   |   |   |
|        | Reset Value |          |    |    |    |    |    |    |    |    |    |    |    |    |              |     |             |    | 0          | 0  | 0   | 0           | 0           | 0 | 0           | 0 | 0           | 0 | 0  | 0 | 0 | 0 | 0 | 0 | 0 | 0 | 0 | 0 | 0 | 0 | 0 | 0 |   |   |
| 068h   | COMP6_FILP  | Reserved |    |    |    |    |    |    |    |    |    |    |    |    | CLKPSC[15:0] |     |             |    |            |    |     |             |             |   |             |   |             |   |    |   |   |   |   |   |   |   |   |   |   |   |   |   |   |   |
|        | Reset Value |          |    |    |    |    |    |    |    |    |    |    |    |    | 0            | 0   | 0           | 0  | 0          | 0  | 0   | 0           | 0           | 0 | 0           | 0 | 0           | 0 | 0  | 0 | 0 | 0 | 0 | 0 | 0 | 0 | 0 | 0 | 0 | 0 | 0 | 0 | 0 | 0 |
| 06Ch   | Reserved    |          |    |    |    |    |    |    |    |    |    |    |    |    |              |     |             |    |            |    |     |             |             |   |             |   |             |   |    |   |   |   |   |   |   |   |   |   |   |   |   |   |   |   |
| 070h   | COMP7_CTRL  | Reserved |    |    |    |    |    |    |    |    |    |    |    |    | INPDAC       | OUT | BLKING[2:0] |    | HYST[1:0]  |    | POL | OUTSEL[3:0] |             |   | INPSEL[2:0] |   | INMSEL[2:0] |   | EN |   |   |   |   |   |   |   |   |   |   |   |   |   |   |   |
|        | Reset Value |          |    |    |    |    |    |    |    |    |    |    |    |    | 0            | 0   | 0           | 0  | 0          | 0  | 0   | 0           | 0           | 0 | 0           | 0 | 0           | 0 | 0  | 0 | 0 | 0 | 0 | 0 | 0 | 0 | 0 | 0 | 0 | 0 | 0 | 0 | 0 | 0 |
| 074h   | COMP7_FILC  | Reserved |    |    |    |    |    |    |    |    |    |    |    |    |              |     |             |    | SAMPW[4:0] |    |     |             | THRESH[4:0] |   |             |   | FILEN       |   |    |   |   |   |   |   |   |   |   |   |   |   |   |   |   |   |
|        | Reset Value |          |    |    |    |    |    |    |    |    |    |    |    |    |              |     |             |    | 0          | 0  | 0   | 0           | 0           | 0 | 0           | 0 | 0           | 0 | 0  | 0 | 0 | 0 | 0 | 0 | 0 | 0 | 0 | 0 | 0 | 0 | 0 | 0 |   |   |
| 078h   | COMP7_FILP  | Reserved |    |    |    |    |    |    |    |    |    |    |    |    | CLKPSC[15:0] |     |             |    |            |    |     |             |             |   |             |   |             |   |    |   |   |   |   |   |   |   |   |   |   |   |   |   |   |   |
|        | Reset Value |          |    |    |    |    |    |    |    |    |    |    |    |    | 0            | 0   | 0           | 0  | 0          | 0  | 0   | 0           | 0           | 0 | 0           | 0 | 0           | 0 | 0  | 0 | 0 | 0 | 0 | 0 | 0 | 0 | 0 | 0 | 0 | 0 | 0 | 0 | 0 | 0 |
| 07Ch   | Reserved    |          |    |    |    |    |    |    |    |    |    |    |    |    |              |     |             |    |            |    |     |             |             |   |             |   |             |   |    |   |   |   |   |   |   |   |   |   |   |   |   |   |   |   |

| Offset | Register     | 31       | 30 | 29 | 28 | 27 | 26 | 25 | 24 | 23 | 22 | 21              | 20 | 19 | 18 | 17 | 16       | 15              | 14 | 13      | 12      | 11      | 10      | 9       | 8       | 7       | 6 | 5 | 4 | 3 | 2 | 1 | 0 |
|--------|--------------|----------|----|----|----|----|----|----|----|----|----|-----------------|----|----|----|----|----------|-----------------|----|---------|---------|---------|---------|---------|---------|---------|---|---|---|---|---|---|---|
| 080h   | COMP_WINMODE | Reserved |    |    |    |    |    |    |    |    |    |                 |    |    |    |    | Reserved |                 |    | CMP56MD | CMP34MD | CMP12MD |         |         |         |         |   |   |   |   |   |   |   |
|        | Reset Value  |          |    |    |    |    |    |    |    |    |    |                 |    |    |    |    |          |                 |    | 0       | 0       | 0       |         |         |         |         |   |   |   |   |   |   |   |
| 084h   | COMP_LOCK    | Reserved |    |    |    |    |    |    |    |    |    |                 |    |    |    |    | Reserved |                 |    | CMP6LK  | CMP5LK  | CMP4LK  | CMP3LK  | CMP2LK  | CMP1LK  |         |   |   |   |   |   |   |   |
|        | Reset Value  |          |    |    |    |    |    |    |    |    |    |                 |    |    |    |    |          |                 |    | 0       | 0       | 0       | 0       | 0       | 0       |         |   |   |   |   |   |   |   |
| 088h   | Reserved     |          |    |    |    |    |    |    |    |    |    |                 |    |    |    |    |          |                 |    |         |         |         |         |         |         |         |   |   |   |   |   |   |   |
| 08Ch   | COMP_INTEN   | Reserved |    |    |    |    |    |    |    |    |    |                 |    |    |    |    | Reserved |                 |    | CMP6IEN | CMP5IEN | CMP4IEN | CMP3IEN | CMP2IEN | CMP1IEN | CMP0IEN |   |   |   |   |   |   |   |
|        | Reset Value  |          |    |    |    |    |    |    |    |    |    |                 |    |    |    |    |          |                 |    | 0       | 0       | 0       | 0       | 0       | 0       | 0       |   |   |   |   |   |   |   |
| 090h   | COMP_INTSTS  | Reserved |    |    |    |    |    |    |    |    |    |                 |    |    |    |    | Reserved |                 |    | CMP7IS  | CMP6IS  | CMP5IS  | CMP4IS  | CMP3IS  | CMP2IS  | CMP1IS  |   |   |   |   |   |   |   |
|        | Reset Value  |          |    |    |    |    |    |    |    |    |    |                 |    |    |    |    |          |                 |    | 0       | 0       | 0       | 0       | 0       | 0       | 0       |   |   |   |   |   |   |   |
| 094h   | COMP_VREFSCL | Reserved |    |    |    |    |    |    |    |    |    | VV2TRM[5:0]     |    |    |    |    | VV2EN    | VV1TRM[15:0]    |    |         |         |         | VV1EN   |         |         |         |   |   |   |   |   |   |   |
|        | Reset Value  |          |    |    |    |    |    |    |    |    |    | 0 0 0 0 0 0 0 0 |    |    |    |    | 0        | 0 0 0 0 0 0 0 0 |    |         |         |         | 0       |         |         |         |   |   |   |   |   |   |   |

## 26.7.2 COMP control register (COMPx\_CTRL)

Comparator 1's INPDAC is valid, comparator 2 to comparator 7, the INPDAC bits are invalid.

Address offset : 0x10,0x20,0x30,0x40,0x50,0x60,0x70

Reset value : 0x0000 0000

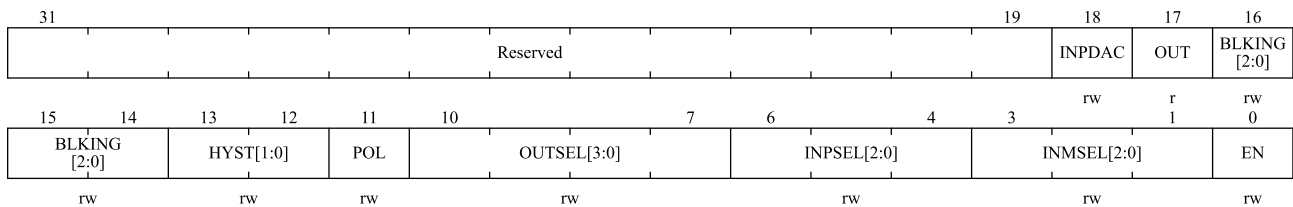

| Bit field | Name        | Description  |
|-----------|-------------|--|
| 31:19     | Reserved    | Reserved, the reset value must be maintained   |
| 18        | INPDAC      | Connection selection of PA1 and DAC output at the non-inverting input of comparator 1<br>0: connect to PA1;<br>1: Connect to DAC output.<br><i>Note: Only COMP1 supports this bit.</i>         |
| 17        | OUT         | This read-only bit is a copy of comparator output state.<br>0: Output is low (non-inverting input below inverting input);<br>1: Output is high (non-inverting input above inverting input).    |
| 16: 14    | BLKING[2:0] | These bits select which Timer output controls the comparator output blanking.<br>000: No blanking;<br>001: TIM1 OC5 selected as blanking source;<br>010: TIM8 OC5 selected as blanking source. |

| Bit field | Name        | Description  |
|-----------|-------------|--|
|           |             | Other configurations: reserved.  |
| 13:12     | HYST[1:0]   | These bits control the hysteresis level.<br>00: No hysteresis;<br>01: Low hysteresis;<br>10: Medium hysteresis;<br>11: High hysteresis.                                |
| 11        | POL         | This bit is used to invert the comparator output.<br>0: Output is not inverted;<br>1: Output is inverted.  |
| 10:7      | OUTSEL[3:0] | Comparator output connection selection<br><i>Note: For the specific enumeration value correspondence, please refer to chapter 26.5 "Comparator interconnection".</i>   |
| 6:4       | INPSEL[2:0] | Comparator non-inverting input selection<br><i>Note: For the specific enumeration value correspondence, please refer to chapter 26.5 "Comparator interconnection".</i> |
| 3:1       | INMSEL[2:0] | Comparator inverting input selection<br><i>Note: For the specific enumeration value correspondence, please refer to chapter 26.5 "Comparator interconnection".</i>     |
| 0         | EN          | This bit switches COMP ON/OFF.<br>0: Comparator disabled;<br>1: Comparator enabled.  |

### 26.7.3 COMP window mode register (COMP\_WINMODE)

Address offset : 0x80

Reset value : 0x0000 0000

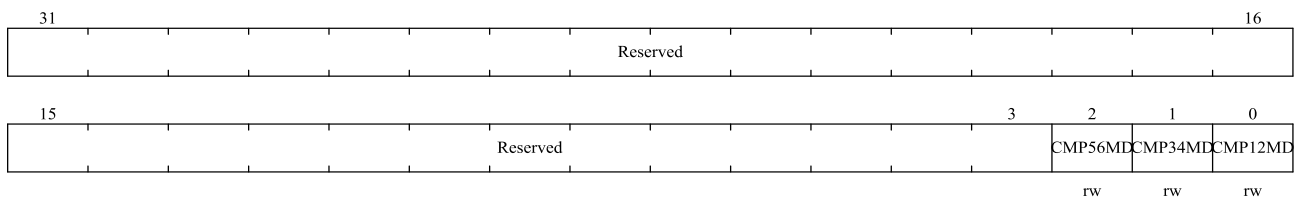

| Bit field | Name     | Description   |
|-----------|----------|---|
| 31:3      | Reserved | Reserved, the reset value must be maintained  |
| 2         | CMP56MD  | This bit selects window mode: the two non-inverting inputs of the comparator share the PC3 or PC4 input.<br>0: Comparators 5 and 6 are not in window mode;<br>1: Comparators 5 and 6 are in window mode.  |
| 1         | CMP34MD  | This bit selects window mode: the two non-inverting inputs of the comparator share the PB14 or PB0 input.<br>0: Comparators 3 and 4 are not in window mode;<br>1: Comparators 4 and 4 are in window mode. |
| 0         | CMP12MD  | This bit selects window mode: the two non-inverting inputs of the comparator share the PA1  |

| Bit field | Name | Description  |
|-----------|------|--|
|           |      | input.<br>0: Comparators 1 and 2 are not in window mode.<br>1: Comparators 1 and 2 are in window mode. |

### 26.7.4 COMP lock register (COMP\_LOCK)

Address offset : 0x84

Reset value : 0x0000 0000

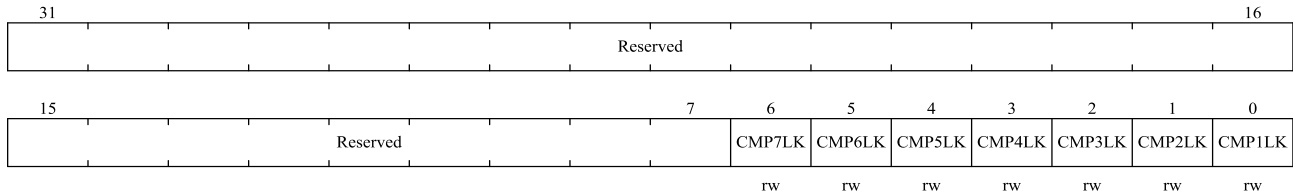

| Bit field | Name     | Description   |
|-----------|----------|---|
| 31:7      | Reserved | Reserved, the reset value must be maintained  |
| 6         | CMP7LK   | This bit is write-once. It is set by software. It can only be cleared by a system reset.<br>If set it causes COMP7_CTRL register to be read-only.<br>0: COMP7_CTRL is read-write.<br>1: COMP7_CTRL is read-only |
| 5         | CMP6LK   | Same function as CMP7LK.  |
| 4         | CMP5LK   | Same function as CMP7LK.  |
| 3         | CMP4LK   | Same function as CMP7LK.  |
| 2         | CMP3LK   | Same function as CMP7LK.  |
| 1         | CMP2LK   | Same function as CMP7LK.  |
| 0         | CMP1LK   | Same function as CMP7LK.  |

### 26.7.5 COMP interrupt enable register (COMP\_INTEN)

Address offset : 0x8C

Reset value : 0x0000 0000

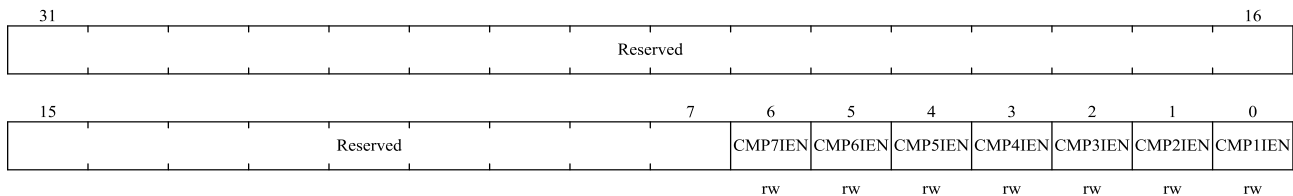

| Bit field | Name     | Description  |
|-----------|----------|--|
| 31:7      | Reserved | Reserved, the reset value must be maintained   |
| 6         | CMP7IEN  | Software controlled Interrupt enable of COMP7.<br>0: Disable;<br>1: Enable.<br><i>Note: COMPx_CTRL.OUT high level triggers an interrupt.</i> |

| Bit field | Name    | Description               |
|-----------|---------|---------------------------|
| 5         | CMP6IEN | Same function as CMP7IEN. |
| 4         | CMP5IEN | Same function as CMP7IEN. |
| 3         | CMP4IEN | Same function as CMP7IEN. |
| 2         | CMP3IEN | Same function as CMP7IEN. |
| 1         | CMP2IEN | Same function as CMP7IEN. |
| 0         | CMP1IEN | Same function as CMP7IEN. |

### 26.7.6 COMP interrupt status register (COMP\_INTSTS)

Address offset : 0x90

Reset value : 0x0000 0000

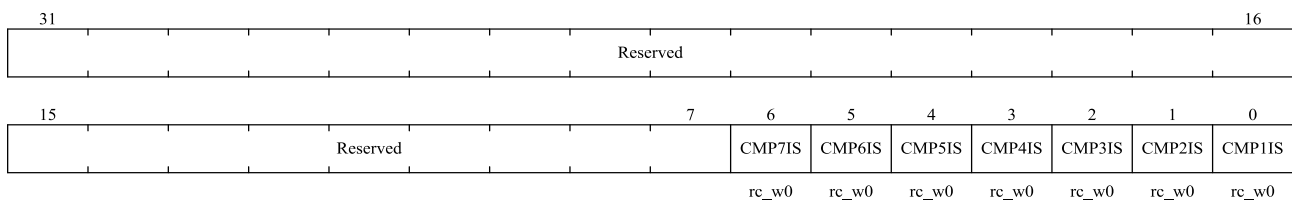

| Bit field | Name     | Description   |
|-----------|----------|---|
| 31:7      | Reserved | Reserved, the reset value must be maintained                      |
| 6         | COMP7IS  | This bit indicate the interrupt status of COMP7,write 0 to clear. |
| 5         | COMP6IS  | Same function as COMP7IS.   |
| 4         | COMP5IS  | Same function as COMP7IS.   |
| 3         | COMP4IS  | Same function as COMP7IS.   |
| 2         | COMP3IS  | Same function as COMP7IS.   |
| 1         | COMP2IS  | Same function as COMP7IS.   |
| 0         | COMP1IS  | Same function as COMP7IS.   |

### 26.7.7 COMP filter register (COMPx\_FILC)

Address offset : 0x14,0x24,0x34,0x44,0x54,0x64,0x74

Reset value : 0x0000 0000

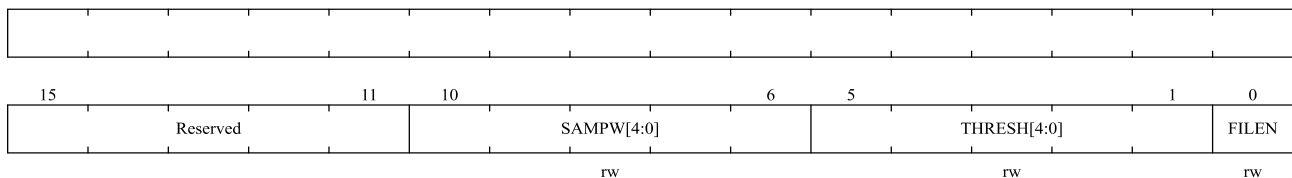

| Bit field | Name        | Description   |
|-----------|-------------|---|
| 31:11     | Reserved    | Reserved, the reset value must be maintained  |
| 10:6      | SAMPW[4:0]  | Filter sampling window size, sampling window = SAMPW + 1.   |
| 5:1       | THRESH[4:0] | The filter threshold is set. At least the sampling threshold of the opposite state in the sample window can change the output state. This value is required to be greater than SAMPW / 2. |
| 0         | FILEN       | Filter enable.  |

| Bit field | Name | Description             |
|-----------|------|-------------------------|
|           |      | 0: Disable<br>1: Enable |

### 26.7.8 COMP filter frequency division register (COMPx\_FILP)

Address offset : 0x18,0x28,0x38,0x48,0x58,0x68,0x78

Reset value : 0x0000 0000

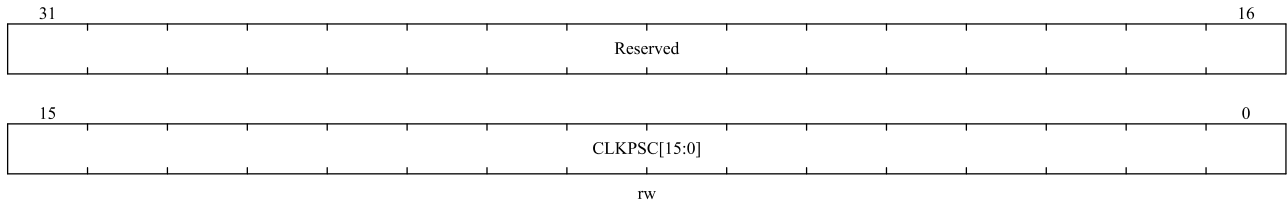

| Bit field | Name         | Description   |
|-----------|--------------|---|
| 31:16     | Reserved     | Reserved, the reset value must be maintained  |
| 15:0      | CLKPSC[15:0] | Low filter sample clock prescale.<br>System clock divider = CLK_PRE_CYCLE + 1,<br>0: Every cycle<br>1: Every 2 cycle<br>2: Every 3 cycle<br>... |

### 26.7.9 COMP reference voltage register (COMP\_VREFSCL)

Address offset : 0x94

Reset value : 0x0000 0000

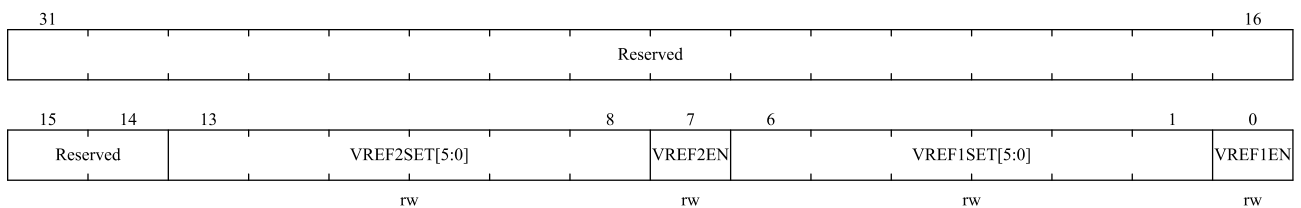

| Bit field | Name          | Description  |
|-----------|---------------|--|
| 31:14     | Reserved      | Reserved, the reset value must be maintained       |
| 13:8      | VREF2SET[5:0] | VREF2 voltage scaler trim value.                   |
| 7         | VREF2EN       | VREF2 voltage scaler:<br>0: disable;<br>1: enable. |
| 6:1       | VREF1SET[5:0] | VREF1 voltage scaler trim value.                   |
| 0         | VREF1EN       | VREF1 voltage scaler:<br>0: disable;               |

| <b>Bit field</b> | <b>Name</b> | <b>Description</b> |
|------------------|-------------|--------------------|
|                  |             | 1: enable.         |

## 27 Operational Amplifier (OPAMP)

The OPAMP module can be flexibly configured, suitable for applications such as independent op amp mode , programmable gain amplifier and follower mode, The internal op-amps can be configured as combined amplifiers with different gains or cascaded using external resistors..OPAMP has an input range of 0V to VDDA and an output range of 0.1V to VDDA-0.1V.

### 27.1 Main features

- Four independently configured operational amps
- Support track-to-track input, input range is 0 to VDDA, output range is 0.1V to VDDA-0.1V programmable gain
- The OPAMP can be configured as an instrument amplifier through an external resistor connection
- The following modes can be configured
  - ◆ Independent op amp mode
  - ◆ Voltage follower
  - ◆ Programmable gain amplifier
  - ◆ Differential op amp of two op amps
- Programmable gain settings are 2X, 4X, 8X, 16X, 32X times
- Gain bandwidth: 4MHz
- Support TIM1\_CC6 to automatically switch the input PIN of OPAMP1 and OPAMP2, TIM8\_CC6 to automatically switch the input PIN of OPAMP3 and OPAMP4
- Independent write protection is supported

#### 27.1.1 OPAMP function description

The four OPAMPs can be configured for various PGA modes through register selection, and can also be configured for the user to use the OPAMP function of external components. The output of the OPAMP can be used as the channel input of the ADC, and the four OPAMP outputs are connected to the analog channels of the ADC as follows.

The output of OPAMP1 is connected to the analog input channel 3 of ADC1

The output of OPAMP2 is connected to the analog input channel 3 of ADC2

The output of OPAMP3 is connected to the analog input channel 1 of ADC3

The output of OPAMP4 is connected to the analog input channel 3 of ADC4

Figure 27-1 Block diagram of OPAMP1 and OPAMP2 connection diagram

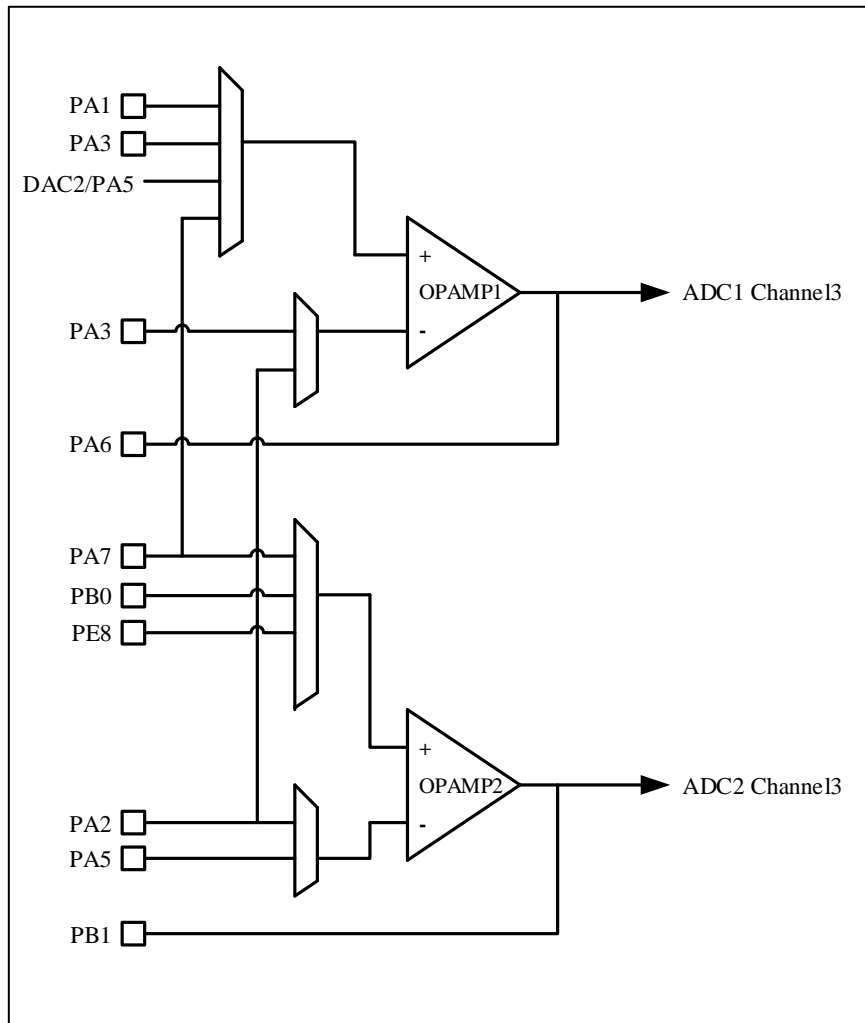
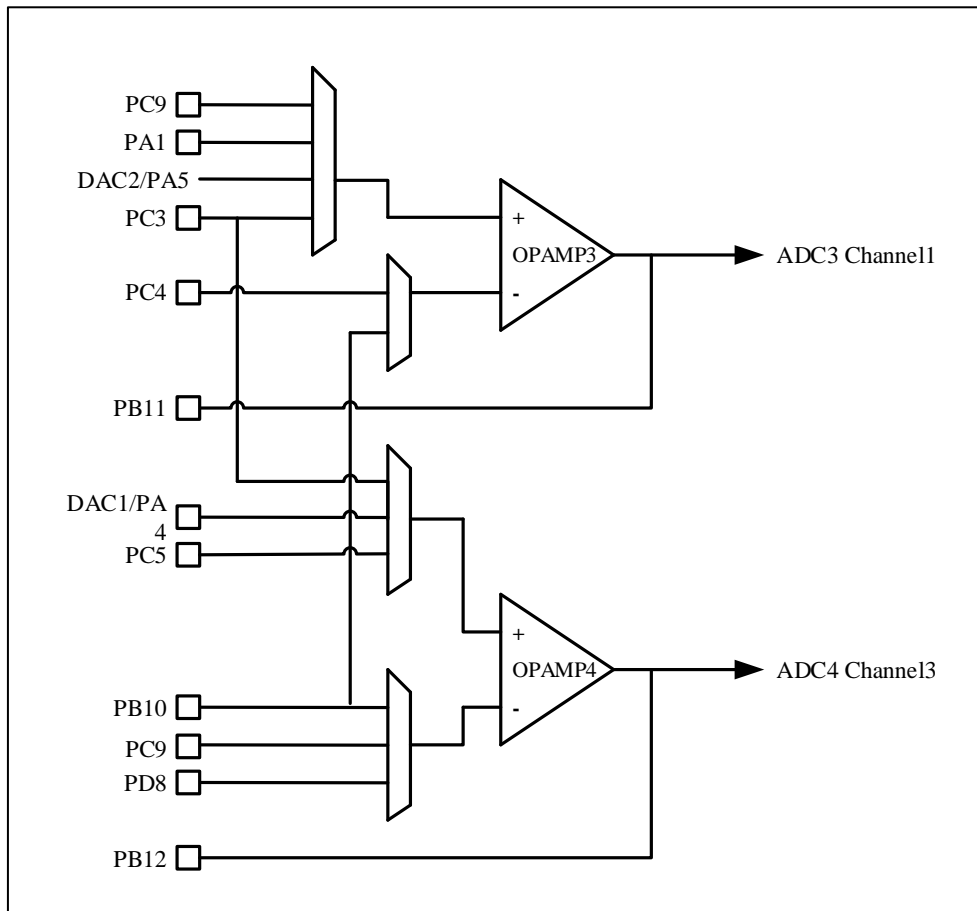

Figure 27-2 Block diagram of OPAMP3 and OPAMP4 connection diagram



### 27.1.2 Internal connection between OPAMP and COMP

OPAMP1, OPAMP2, COMP1, COMP2, COMP3, ADC1 and ADC2 constitute a group of analog linkage applications, and the topology relationship is as follows:

Figure 27-3 Simulation module linkage relationship 1

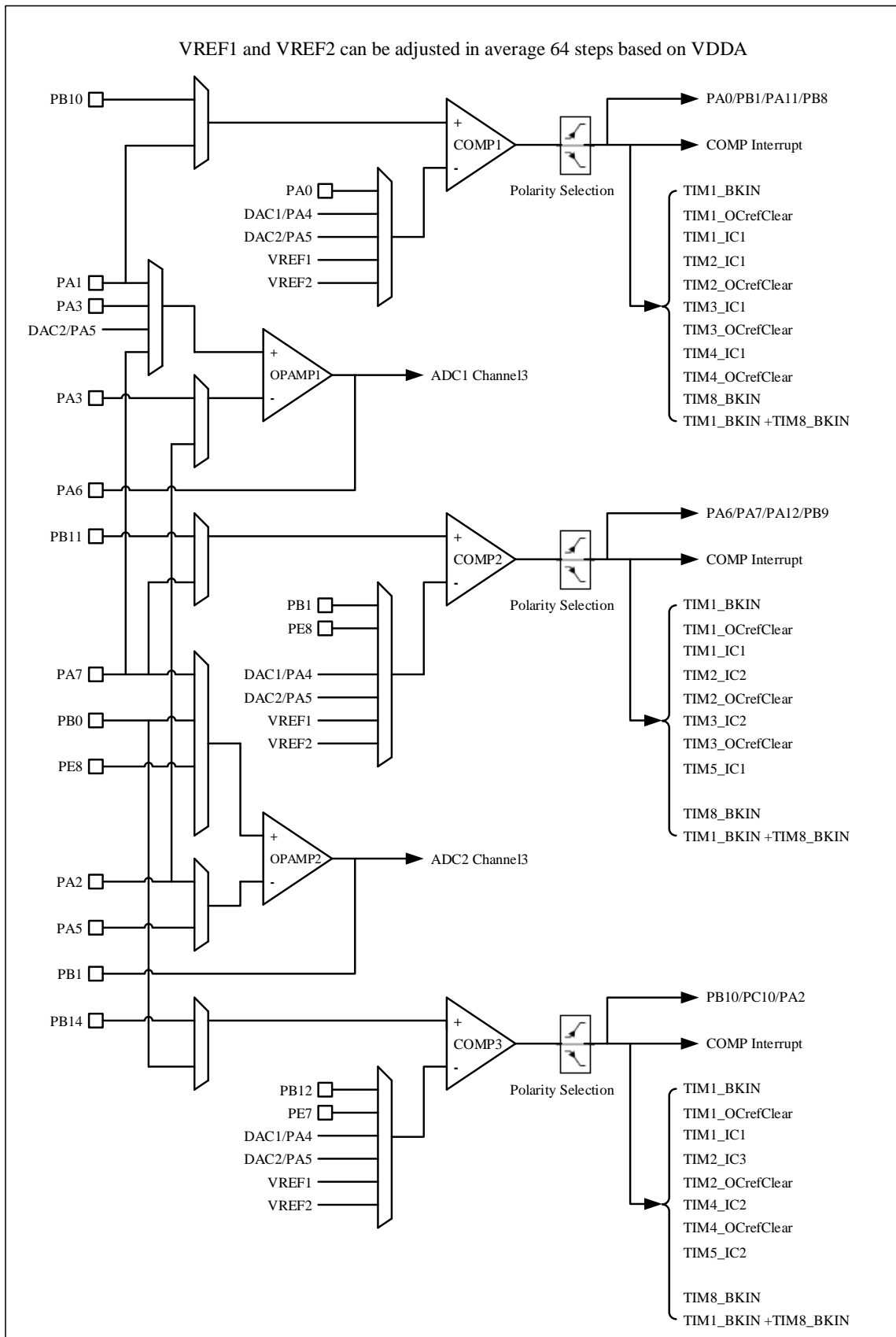

OPAMP3, OPAMP4, COMP4, COMP5, COMP6, ADC3 and ADC4 constitute a group of analog linkage applications, and the topology relationship is as follows:

Figure 27-4 Simulation module linkage relationship 2



## 27.2 OPAMP working mode

### 27.2.1 OPAMP independent op amp mode

The amplification factor of the independent op amp mode is determined by the connected resistance and capacitance. When `OPAMPx_CS.MOD` is set to `2'b00` or `2'b01`, it is the op amp function, `OPAMPx_CS.VPSSEL` or `OPAMPx_CS.VPSEL` selects the positive input, and `OPAMPx_CS.VMSSEL` or `OPAMPx_CS.VMSEL` selects the negative input. Use an external resistor to form a closed-loop amplification system.

Four completely independent OPAMPs. At this time, the gain is determined by the external resistor network. It can also be cascaded as required to form the required amplification gain. As shown in the figure below, the positive terminal, negative terminal and output terminal of the OPAMP are connected to the external port, the amplification factor is determined by the external RC network.

Figure 27-5 OPAMP standalone operational amplifier mode

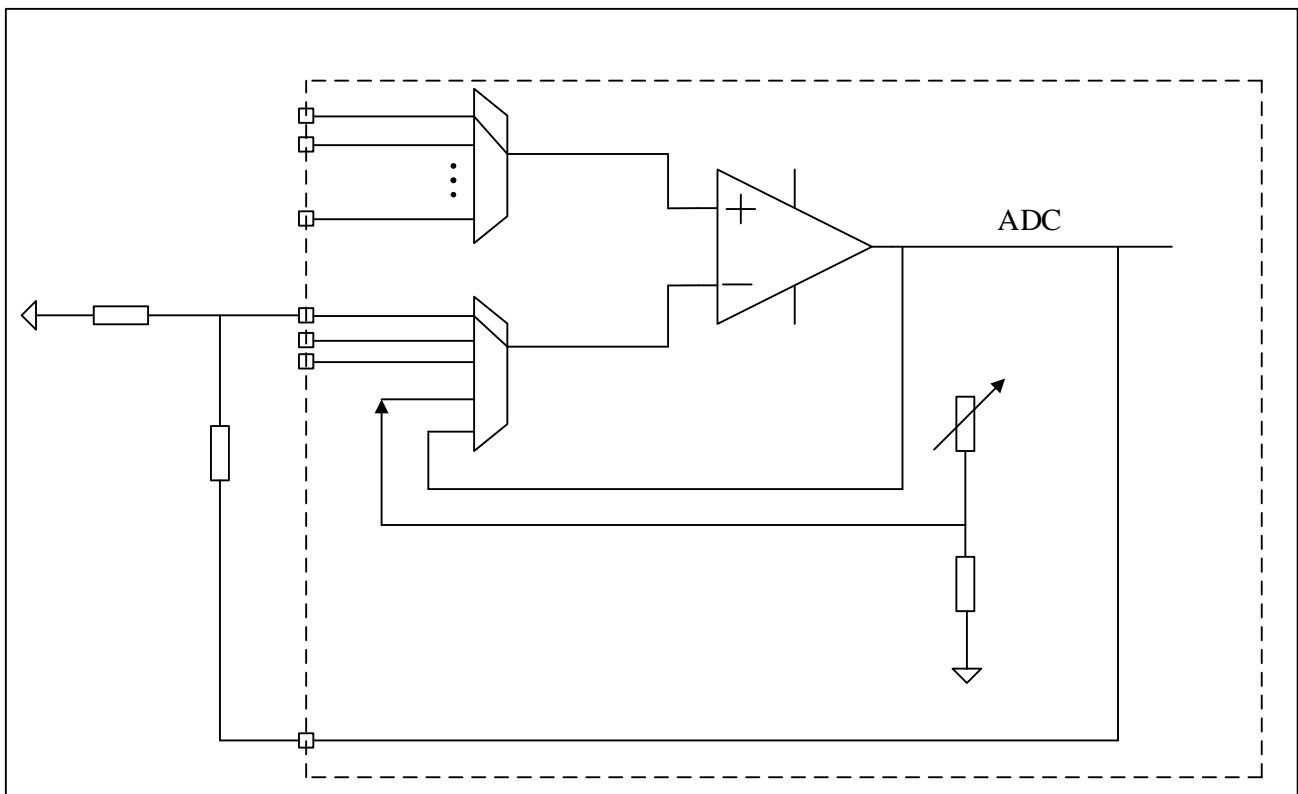

### 27.2.2 OPAMP follow mode

In follow mode, the voltage is directly follow. The `VMSEL` terminal must be directly connected to the OPAMP output port.

`OPAMPx_CS.MOD = 2b'11` is the internal follow function, `OPAMPx_CS.VPSSEL` or `OPAMPx_CS.VPSEL` selects the positive end input, `OPAMPx_CS.VMSSEL` or `OPAMPx_CS.VMSEL` is connected to the output port from the chip interior.

A VM pin that is not occupied can be used as another GPIO.

Figure 27-6 Follow mode

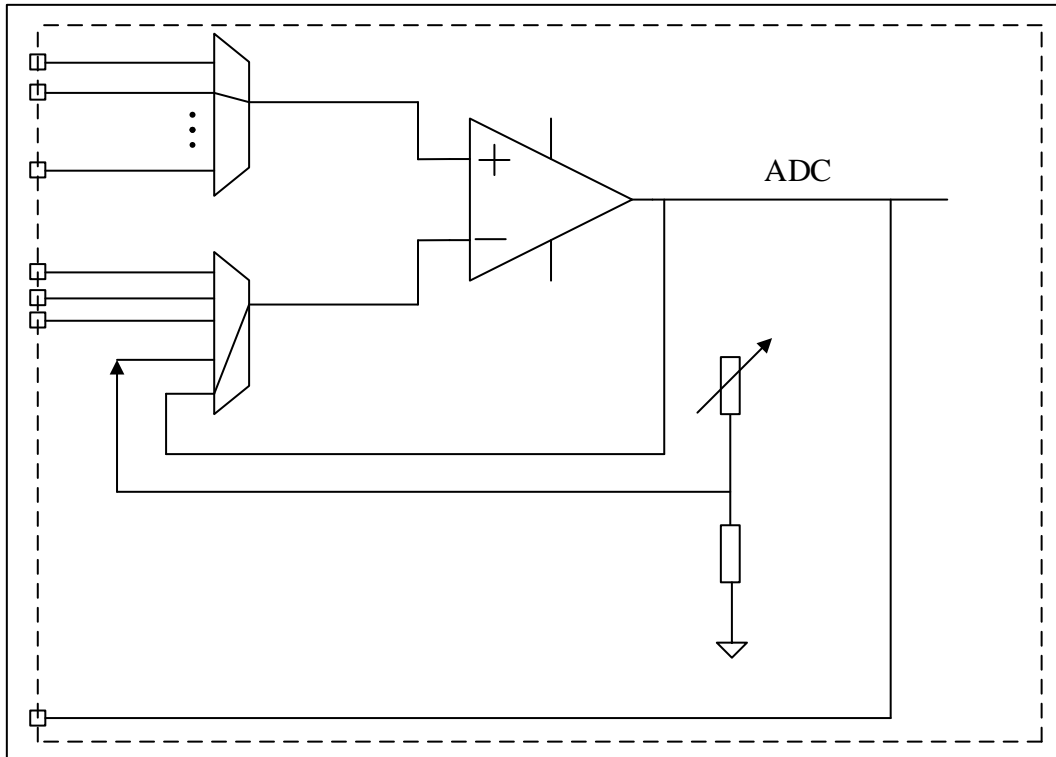

### 27.2.3 OPAMP internal gain (PGA) mode

The internal amplification mode, amplifies the input voltage through a built-in resistor feedback network.

OPAMPx\_CS. MOD = 2b'10 is a PGA function that supports 2/4/8/16/32 magnification. OPAMPx\_CS. VMSEL or OPAMPx\_CS. VMSEL pins must be set to float. OPAMPx\_CS.VPSSEL or OPAMPx\_CS.VPSEL select positive input. The positive input can be connected to an external pin, which can be an output port for another OPAMP or a resistive network. Set OPAMPx\_CS. PGAGAN to gain selection. The output of an OPAMP can be input to another OPAMP or a resistive network.

OPAMP's VM input pin can be used as a normal GPIO.

Figure 27-7 Internal gain mode

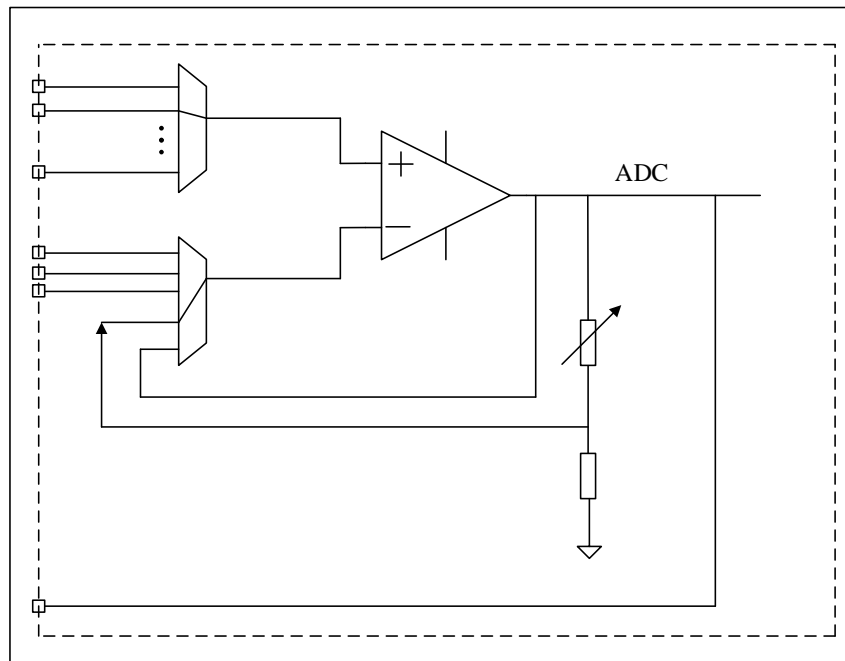

### 27.2.4 OPAMP with filter internal gain mode

In this mode, the amplification voltage is adjustable, supports 2/4/8/16/32, and the OPAMPx\_CS.VPSSEL or OPAMAPx\_CS.VPSEL is set to be connected to the external pin, and the negative of OPAMP can be connected to components such as capacitors.

Figure 27-8 Internal gain mode with filter

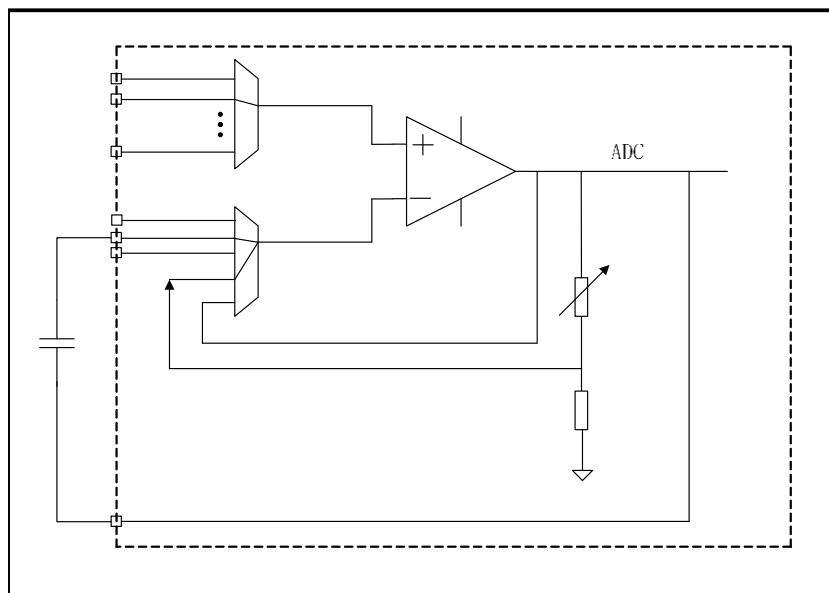

## 27.2.5 OPAMP calibration

The chip has been calibrated before delivery. Users can calibrate the chip again according to the actual environment.

*Note: Contact NSING for specific calibration methods to obtain relevant information.*

## 27.2.6 OPAMP independent write protection

By configuring the OPAMP\_LOCK register, the write protection of OPAMP can be set independently. After the write protection is set, the software cannot write to the corresponding OPAMP register. Only after the chip is reset, the write protection can be cancelled.

## 27.2.7 OPAMP TIMER controls the switching mode

In some applications, the input switching of the OPAMP can be performed through TIMx\_CC6. TIM1\_CC6 controls the input switching of OPAMP1 and OPAMP2, and TIM8\_CC6 controls the input switching of OPAMP3 and OPAMP4.

When TIM1\_CC6 is high, OPAMP1 and OPAMP2 select the port configured by VPSSEL/VMSEL as input, otherwise use VPSEL/VMSEL. When TIM8\_CC6 is high, OPAMP3 and OPAMP4 select the port configured by VPSSEL/VMSEL as input, otherwise use VPSEL/VMSEL.

Set OPAMPx\_CS.TCMEN to 1 to enable the automatic switchover input function. The process for configuring the automatic switchover is as follows:

- Enable automatic switching function OPAMPx\_CS.TCMEN (OPAMP independent control)
- Configured two conversion MUX configuration (VPSEL, VMSEL, VPSSEL, VMSEL)
- Start OPAMP and TIM

## 27.3 OPAMP register

### 27.3.1 OPAMP register overview

Table 27-1 OPAMP register overview

| Offset | Register    | 31       | 30 | 29 | 28 | 27 | 26 | 25 | 24 | 23 | 22 | 21 | 20          | 19 | 18 | 17         | 16 | 15 | 14    | 13    | 12     | 11     | 10       | 9     | 8           | 7 | 6 | 5          | 4 | 3 | 2           | 1 | 0 |          |   |    |
|--------|-------------|----------|----|----|----|----|----|----|----|----|----|----|-------------|----|----|------------|----|----|-------|-------|--------|--------|----------|-------|-------------|---|---|------------|---|---|-------------|---|---|----------|---|----|
| 000h   | OPAMP_CS1   | Reserved |    |    |    |    |    |    |    |    |    |    | VPSSEL[2:0] |    |    | VMSEL[1:0] |    |    | TCMEN | RANGE | CALOUT | TSTREF | Reserved | CALON | VPSSEL[2:0] |   |   | VMSEL[1:0] |   |   | PGAGAN[2:0] |   |   | MOD[1:0] |   | EN |
|        | Reset Value | 0        | 0  | 0  | 0  | 0  | 0  | 0  | 0  | 0  | 0  | 0  | 0           | 0  | 0  | 0          | 0  | 0  | 0     | 0     | 0      | 0      | 0        | 0     | 0           | 0 | 0 | 0          | 0 | 0 | 0           | 0 | 0 | 0        |   |    |
| 010h   | OPAMP_CS2   | Reserved |    |    |    |    |    |    |    |    |    |    | VPSSEL[2:0] |    |    | VMSEL[1:0] |    |    | TCMEN | RANGE | CALOUT | TSTREF | Reserved | CALON | VPSSEL[2:0] |   |   | VMSEL[1:0] |   |   | PGAGAN[2:0] |   |   | MOD[1:0] |   | EN |
|        | Reset Value | 0        | 0  | 0  | 0  | 0  | 0  | 0  | 0  | 0  | 0  | 0  | 0           | 0  | 0  | 0          | 0  | 0  | 0     | 0     | 0      | 0      | 0        | 0     | 0           | 0 | 0 | 0          | 0 | 0 | 0           | 0 | 0 | 0        | 0 |    |
| 020h   | OPAMP_CS3   | Reserved |    |    |    |    |    |    |    |    |    |    | VPSSEL[2:0] |    |    | VMSEL[1:0] |    |    | TCMEN | RANGE | CALOUT | TSTREF | Reserved | CALON | VPSSEL[2:0] |   |   | VMSEL[1:0] |   |   | PGAGAN[2:0] |   |   | MOD[1:0] |   | EN |
|        | Reset Value | 0        | 0  | 0  | 0  | 0  | 0  | 0  | 0  | 0  | 0  | 0  | 0           | 0  | 0  | 0          | 0  | 0  | 0     | 0     | 0      | 0      | 0        | 0     | 0           | 0 | 0 | 0          | 0 | 0 | 0           | 0 | 0 | 0        | 0 |    |

| Offset | Register    | 31       | 30 | 29 | 28 | 27 | 26 | 25 | 24 | 23 | 22 | 21         | 20 | 19         | 18 | 17    | 16    | 15     | 14     | 13       | 12    | 11         | 10 | 9          | 8 | 7           | 6        | 5        | 4        | 3        | 2 | 1 | 0 |
|--------|-------------|----------|----|----|----|----|----|----|----|----|----|------------|----|------------|----|-------|-------|--------|--------|----------|-------|------------|----|------------|---|-------------|----------|----------|----------|----------|---|---|---|
| 030h   | OPAMP_CS4   | Reserved |    |    |    |    |    |    |    |    |    | VPSEL[2:0] |    | VMSEL[1:0] |    | TCMEN | RANGE | CALOUT | TSTREF | Reserved | CALON | VPSEL[2:0] |    | VMSEL[1:0] |   | PGAGAN[2:0] |          | MOD[1:0] |          | EN       |   |   |   |
|        | Reset Value |          |    |    |    |    |    |    |    |    |    | 0          | 0  | 0          | 0  | 0     | 0     | 0      | 0      | 0        | 0     | 0          | 0  | 0          | 0 | 0           | 0        | 0        | 0        | 0        | 0 | 0 | 0 |
| 040h   | OPAMP_LOCK  | Reserved |    |    |    |    |    |    |    |    |    |            |    |            |    |       |       |        |        |          |       |            |    |            |   |             | OPAMP4LK | OPAMP3LK | OPAMP2LK | OPAMP1LK |   |   |   |
|        | Reset Value |          |    |    |    |    |    |    |    |    |    |            |    |            |    |       |       |        |        |          |       |            |    |            |   |             | 0        | 0        | 0        | 0        |   |   |   |

### 27.3.2 OPAMP Control Status Register (OPAMPx\_CS)

Offset address: 0x00,0x10,0x20,0x30

Reset value: 0x0000 0000

|          |        |        |          |       |       |  |       |  |        |       |     |       |    |       |
|----------|--------|--------|----------|-------|-------|--|-------|--|--------|-------|-----|-------|----|-------|
| Reserved |        |        |          |       |       |  |       |  |        | VPSEL |     | VMSEL |    | TCMEN |
|          |        |        |          |       |       |  |       |  |        | rw    |     | rw    |    | rw    |
| RANGE    | CALOUT | TSTREF | Reserved | CALON | VPSEL |  | VMSEL |  | PGAGAN |       | MOD |       | EN |       |
| rw       | r      | rw     |          | rw    | rw    |  | rw    |  | rw     |       | rw  |       | rw |       |

| Bit field  | Name       | Description  |            |          |          |          |        |     |     |     |     |      |     |     |     |      |          |     |          |          |          |     |     |          |          |          |          |     |          |          |          |          |        |          |          |          |          |
|--|------------|--|------------|----------|----------|----------|--------|-----|-----|-----|-----|------|-----|-----|-----|------|----------|-----|----------|----------|----------|-----|-----|----------|----------|----------|----------|-----|----------|----------|----------|----------|--------|----------|----------|----------|----------|
| 31:22  | Reserved   | Retained, the reset value must be maintained.  |            |          |          |          |        |     |     |     |     |      |     |     |     |      |          |     |          |          |          |     |     |          |          |          |          |     |          |          |          |          |        |          |          |          |          |
| 21:19  | VPSEL[2:0] | OPAMP non inverted input secondary selection   |            |          |          |          |        |     |     |     |     |      |     |     |     |      |          |     |          |          |          |     |     |          |          |          |          |     |          |          |          |          |        |          |          |          |          |
|  |            | <table border="1"> <thead> <tr> <th>VPSEL[2:0]</th> <th>OPAMP1</th> <th>OPAMP2</th> <th>OPAMP3</th> <th>OPAMP4</th> </tr> </thead> <tbody> <tr> <td>000</td> <td>PA1</td> <td>PA7</td> <td>PC9</td> <td>PC3</td> </tr> <tr> <td>001</td> <td>PA3</td> <td>PB0</td> <td>PA1</td> <td>DAC1/PA4</td> </tr> <tr> <td>010</td> <td>DAC2/PA5</td> <td>PE8</td> <td>DAC2/PA5</td> <td>PC5</td> </tr> <tr> <td>011</td> <td>PA7</td> <td>Reserved</td> <td>PC3</td> <td>Reserved</td> </tr> <tr> <td>100</td> <td>Reserved</td> <td>Reserved</td> <td>Reserved</td> <td>Reserved</td> </tr> <tr> <td>others</td> <td>Reserved</td> <td>Reserved</td> <td>Reserved</td> <td>Reserved</td> </tr> </tbody> </table> | VPSEL[2:0] | OPAMP1   | OPAMP2   | OPAMP3   | OPAMP4 | 000 | PA1 | PA7 | PC9 | PC3  | 001 | PA3 | PB0 | PA1  | DAC1/PA4 | 010 | DAC2/PA5 | PE8      | DAC2/PA5 | PC5 | 011 | PA7      | Reserved | PC3      | Reserved | 100 | Reserved | Reserved | Reserved | Reserved | others | Reserved | Reserved | Reserved | Reserved |
|  |            | VPSEL[2:0]   | OPAMP1     | OPAMP2   | OPAMP3   | OPAMP4   |        |     |     |     |     |      |     |     |     |      |          |     |          |          |          |     |     |          |          |          |          |     |          |          |          |          |        |          |          |          |          |
|  |            | 000  | PA1        | PA7      | PC9      | PC3      |        |     |     |     |     |      |     |     |     |      |          |     |          |          |          |     |     |          |          |          |          |     |          |          |          |          |        |          |          |          |          |
|  |            | 001  | PA3        | PB0      | PA1      | DAC1/PA4 |        |     |     |     |     |      |     |     |     |      |          |     |          |          |          |     |     |          |          |          |          |     |          |          |          |          |        |          |          |          |          |
|  |            | 010  | DAC2/PA5   | PE8      | DAC2/PA5 | PC5      |        |     |     |     |     |      |     |     |     |      |          |     |          |          |          |     |     |          |          |          |          |     |          |          |          |          |        |          |          |          |          |
|  |            | 011  | PA7        | Reserved | PC3      | Reserved |        |     |     |     |     |      |     |     |     |      |          |     |          |          |          |     |     |          |          |          |          |     |          |          |          |          |        |          |          |          |          |
| 100  | Reserved   | Reserved   | Reserved   | Reserved |          |          |        |     |     |     |     |      |     |     |     |      |          |     |          |          |          |     |     |          |          |          |          |     |          |          |          |          |        |          |          |          |          |
| others   | Reserved   | Reserved   | Reserved   | Reserved |          |          |        |     |     |     |     |      |     |     |     |      |          |     |          |          |          |     |     |          |          |          |          |     |          |          |          |          |        |          |          |          |          |
| <i>Note: DAC2 is directly connected to PA5</i>                               |            |  |            |          |          |          |        |     |     |     |     |      |     |     |     |      |          |     |          |          |          |     |     |          |          |          |          |     |          |          |          |          |        |          |          |          |          |
| 18:17  | VMSEL[1:0] | OPAMP inverted input secondary selection   |            |          |          |          |        |     |     |     |     |      |     |     |     |      |          |     |          |          |          |     |     |          |          |          |          |     |          |          |          |          |        |          |          |          |          |
|  |            | <table border="1"> <thead> <tr> <th>VMSEL[1:0]</th> <th>OPAMP1</th> <th>OPAMP2</th> <th>OPAMP3</th> <th>OPAMP4</th> </tr> </thead> <tbody> <tr> <td>00</td> <td>PA3</td> <td>PA2</td> <td>PC4</td> <td>PB10</td> </tr> <tr> <td>01</td> <td>PA2</td> <td>PA5</td> <td>PB10</td> <td>PC9</td> </tr> <tr> <td>10</td> <td>Reserved</td> <td>Reserved</td> <td>Reserved</td> <td>PD8</td> </tr> <tr> <td>11</td> <td>Floating</td> <td>Floating</td> <td>Floating</td> <td>Floating</td> </tr> </tbody> </table>  | VMSEL[1:0] | OPAMP1   | OPAMP2   | OPAMP3   | OPAMP4 | 00  | PA3 | PA2 | PC4 | PB10 | 01  | PA2 | PA5 | PB10 | PC9      | 10  | Reserved | Reserved | Reserved | PD8 | 11  | Floating | Floating | Floating | Floating |     |          |          |          |          |        |          |          |          |          |
|  |            | VMSEL[1:0]   | OPAMP1     | OPAMP2   | OPAMP3   | OPAMP4   |        |     |     |     |     |      |     |     |     |      |          |     |          |          |          |     |     |          |          |          |          |     |          |          |          |          |        |          |          |          |          |
|  |            | 00   | PA3        | PA2      | PC4      | PB10     |        |     |     |     |     |      |     |     |     |      |          |     |          |          |          |     |     |          |          |          |          |     |          |          |          |          |        |          |          |          |          |
|  |            | 01   | PA2        | PA5      | PB10     | PC9      |        |     |     |     |     |      |     |     |     |      |          |     |          |          |          |     |     |          |          |          |          |     |          |          |          |          |        |          |          |          |          |
| 10   | Reserved   | Reserved   | Reserved   | PD8      |          |          |        |     |     |     |     |      |     |     |     |      |          |     |          |          |          |     |     |          |          |          |          |     |          |          |          |          |        |          |          |          |          |
| 11   | Floating   | Floating   | Floating   | Floating |          |          |        |     |     |     |     |      |     |     |     |      |          |     |          |          |          |     |     |          |          |          |          |     |          |          |          |          |        |          |          |          |          |
| <i>Note: VM is floating (for internal PGA (No Filter) mode, follow mode)</i> |            |  |            |          |          |          |        |     |     |     |     |      |     |     |     |      |          |     |          |          |          |     |     |          |          |          |          |     |          |          |          |          |        |          |          |          |          |
| 16   | TCMEN      | Timer controlled Mux mode enable.<br><br>This bit is set or cleared by software to control the automatic switching between primary and secondary inputs (VPSEL, VMSEL and VPSEL, VMSEL).<br><br>TIM1_CC6 automatically switches between OPAMP1 and OPAMP2, and TIM8_CC6  |            |          |          |          |        |     |     |     |     |      |     |     |     |      |          |     |          |          |          |     |     |          |          |          |          |     |          |          |          |          |        |          |          |          |          |

| Bit field  | Name        | Description   |            |          |        |        |        |     |     |     |     |      |     |     |     |      |          |     |          |          |          |     |     |          |          |          |          |     |          |          |          |          |        |          |          |          |          |
|------------|-------------|---|------------|----------|--------|--------|--------|-----|-----|-----|-----|------|-----|-----|-----|------|----------|-----|----------|----------|----------|-----|-----|----------|----------|----------|----------|-----|----------|----------|----------|----------|--------|----------|----------|----------|----------|
|            |             | automatically switches between OPAMP3 and OPAMP4.<br>0: Disable automatic switching;<br>1: Enable automatic switching.  |            |          |        |        |        |     |     |     |     |      |     |     |     |      |          |     |          |          |          |     |     |          |          |          |          |     |          |          |          |          |        |          |          |          |          |
| 15         | RANGE       | OPAMP voltage range (OPAMP Operational amplifier power supply range).<br>0: Low voltage range (VDDA < 2.4V);<br>1: High voltage range.  |            |          |        |        |        |     |     |     |     |      |     |     |     |      |          |     |          |          |          |     |     |          |          |          |          |     |          |          |          |          |        |          |          |          |          |
| 14         | CALOUT      | OPAMP calibration output (Operation amplifier calibration output)<br>When this signal toggles, the offset during calibration mode is calibrated.  |            |          |        |        |        |     |     |     |     |      |     |     |     |      |          |     |          |          |          |     |     |          |          |          |          |     |          |          |          |          |        |          |          |          |          |
| 13         | TSTREF      | Retained, the reset value must be maintained.   |            |          |        |        |        |     |     |     |     |      |     |     |     |      |          |     |          |          |          |     |     |          |          |          |          |     |          |          |          |          |        |          |          |          |          |
| 12         | Reserved    | Retained, the reset value must be maintained.   |            |          |        |        |        |     |     |     |     |      |     |     |     |      |          |     |          |          |          |     |     |          |          |          |          |     |          |          |          |          |        |          |          |          |          |
| 11         | CALON       | Calibration mode enabled<br>0: Normal mode;<br>1: Calibration mode.   |            |          |        |        |        |     |     |     |     |      |     |     |     |      |          |     |          |          |          |     |     |          |          |          |          |     |          |          |          |          |        |          |          |          |          |
| 10:8       | VPSEL[2:0]  | OPAMP non inverted input selection <table border="1" data-bbox="592 824 1428 1126"> <thead> <tr> <th>VPSEL[2:0]</th> <th>OPAMP1</th> <th>OPAMP2</th> <th>OPAMP3</th> <th>OPAMP4</th> </tr> </thead> <tbody> <tr> <td>000</td> <td>PA1</td> <td>PA7</td> <td>PC9</td> <td>PC3</td> </tr> <tr> <td>001</td> <td>PA3</td> <td>PB0</td> <td>PA1</td> <td>DAC1/PA4</td> </tr> <tr> <td>010</td> <td>DAC2/PA5</td> <td>PE8</td> <td>DAC2/PA5</td> <td>PC5</td> </tr> <tr> <td>011</td> <td>PA7</td> <td>Reserved</td> <td>PC3</td> <td>Reserved</td> </tr> <tr> <td>100</td> <td>Reserved</td> <td>Reserved</td> <td>Reserved</td> <td>Reserved</td> </tr> <tr> <td>others</td> <td>Reserved</td> <td>Reserved</td> <td>Reserved</td> <td>Reserved</td> </tr> </tbody> </table> <p><i>Note: DAC2 is directly connected to PA5</i></p> | VPSEL[2:0] | OPAMP1   | OPAMP2 | OPAMP3 | OPAMP4 | 000 | PA1 | PA7 | PC9 | PC3  | 001 | PA3 | PB0 | PA1  | DAC1/PA4 | 010 | DAC2/PA5 | PE8      | DAC2/PA5 | PC5 | 011 | PA7      | Reserved | PC3      | Reserved | 100 | Reserved | Reserved | Reserved | Reserved | others | Reserved | Reserved | Reserved | Reserved |
| VPSEL[2:0] | OPAMP1      | OPAMP2  | OPAMP3     | OPAMP4   |        |        |        |     |     |     |     |      |     |     |     |      |          |     |          |          |          |     |     |          |          |          |          |     |          |          |          |          |        |          |          |          |          |
| 000        | PA1         | PA7   | PC9        | PC3      |        |        |        |     |     |     |     |      |     |     |     |      |          |     |          |          |          |     |     |          |          |          |          |     |          |          |          |          |        |          |          |          |          |
| 001        | PA3         | PB0   | PA1        | DAC1/PA4 |        |        |        |     |     |     |     |      |     |     |     |      |          |     |          |          |          |     |     |          |          |          |          |     |          |          |          |          |        |          |          |          |          |
| 010        | DAC2/PA5    | PE8   | DAC2/PA5   | PC5      |        |        |        |     |     |     |     |      |     |     |     |      |          |     |          |          |          |     |     |          |          |          |          |     |          |          |          |          |        |          |          |          |          |
| 011        | PA7         | Reserved  | PC3        | Reserved |        |        |        |     |     |     |     |      |     |     |     |      |          |     |          |          |          |     |     |          |          |          |          |     |          |          |          |          |        |          |          |          |          |
| 100        | Reserved    | Reserved  | Reserved   | Reserved |        |        |        |     |     |     |     |      |     |     |     |      |          |     |          |          |          |     |     |          |          |          |          |     |          |          |          |          |        |          |          |          |          |
| others     | Reserved    | Reserved  | Reserved   | Reserved |        |        |        |     |     |     |     |      |     |     |     |      |          |     |          |          |          |     |     |          |          |          |          |     |          |          |          |          |        |          |          |          |          |
| 7:6        | VMSEL[1:0]  | OPAMP inverted input selection <table border="1" data-bbox="592 1211 1428 1424"> <thead> <tr> <th>VMSEL[1:0]</th> <th>OPAMP1</th> <th>OPAMP2</th> <th>OPAMP3</th> <th>OPAMP4</th> </tr> </thead> <tbody> <tr> <td>00</td> <td>PA3</td> <td>PA2</td> <td>PC4</td> <td>PB10</td> </tr> <tr> <td>01</td> <td>PA2</td> <td>PA5</td> <td>PB10</td> <td>PC9</td> </tr> <tr> <td>10</td> <td>Reserved</td> <td>Reserved</td> <td>Reserved</td> <td>PD8</td> </tr> <tr> <td>11</td> <td>Floating</td> <td>Floating</td> <td>Floating</td> <td>Floating</td> </tr> </tbody> </table> <p><i>Note: VM is floating (for internal PGA (No Filter) mode, follow mode)</i></p>   | VMSEL[1:0] | OPAMP1   | OPAMP2 | OPAMP3 | OPAMP4 | 00  | PA3 | PA2 | PC4 | PB10 | 01  | PA2 | PA5 | PB10 | PC9      | 10  | Reserved | Reserved | Reserved | PD8 | 11  | Floating | Floating | Floating | Floating |     |          |          |          |          |        |          |          |          |          |
| VMSEL[1:0] | OPAMP1      | OPAMP2  | OPAMP3     | OPAMP4   |        |        |        |     |     |     |     |      |     |     |     |      |          |     |          |          |          |     |     |          |          |          |          |     |          |          |          |          |        |          |          |          |          |
| 00         | PA3         | PA2   | PC4        | PB10     |        |        |        |     |     |     |     |      |     |     |     |      |          |     |          |          |          |     |     |          |          |          |          |     |          |          |          |          |        |          |          |          |          |
| 01         | PA2         | PA5   | PB10       | PC9      |        |        |        |     |     |     |     |      |     |     |     |      |          |     |          |          |          |     |     |          |          |          |          |     |          |          |          |          |        |          |          |          |          |
| 10         | Reserved    | Reserved  | Reserved   | PD8      |        |        |        |     |     |     |     |      |     |     |     |      |          |     |          |          |          |     |     |          |          |          |          |     |          |          |          |          |        |          |          |          |          |
| 11         | Floating    | Floating  | Floating   | Floating |        |        |        |     |     |     |     |      |     |     |     |      |          |     |          |          |          |     |     |          |          |          |          |     |          |          |          |          |        |          |          |          |          |
| 5:3        | PGAGAN[2:0] | OPAMP gain setting (Operational amplifier Programmable amplifier gain value)<br>000: Internal PGA gain 2;<br>001: Internal PGA gain 4;<br>010: Internal PGA gain 8;<br>011: Internal PGA gain 16;<br>100: Internal PGA gain 32;<br>Others: Internal PGA gain 2.   |            |          |        |        |        |     |     |     |     |      |     |     |     |      |          |     |          |          |          |     |     |          |          |          |          |     |          |          |          |          |        |          |          |          |          |
| 2:1        | MOD[1:0]    | OPAMP mode selection (Operational amplifier PGA mode)<br>0x: External zoom mode;<br>10: Internal PGA enable;<br>11: Internal follow mode.   |            |          |        |        |        |     |     |     |     |      |     |     |     |      |          |     |          |          |          |     |     |          |          |          |          |     |          |          |          |          |        |          |          |          |          |
| 0          | EN          | OPAMP Enable (Operational amplifier Enable)<br>0: Disable;  |            |          |        |        |        |     |     |     |     |      |     |     |     |      |          |     |          |          |          |     |     |          |          |          |          |     |          |          |          |          |        |          |          |          |          |

| Bit field | Name | Description |
|-----------|------|-------------|
|           |      | 1: Enable.  |

### 27.3.3 OPAMP Lock register (OPAMP\_LOCK)

Offset address: 0x40

Reset value: 0x0000 0000

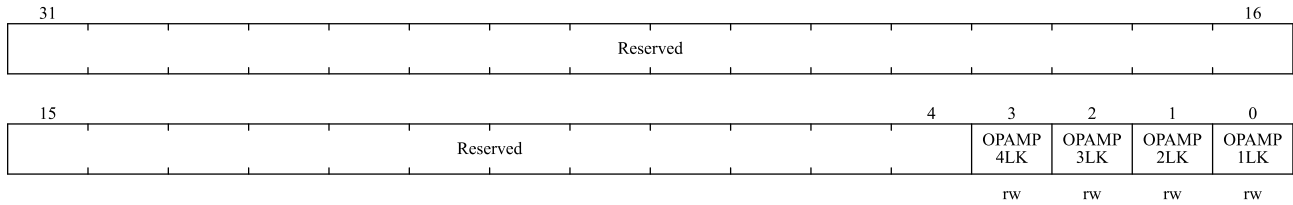

| Bit field | Name     | Description   |
|-----------|----------|---|
| 31:4      | Reserved | Reserved, the reset value must be maintained  |
| 3         | OPAMP4LK | OPAMP4 lock (OPAMP4 lock bit)<br>After the reset, this bit can be written only once<br>0: OPAMP4 register can read and write;<br>1: OPAMP4 register is read-only. |
| 2         | OPAMP3LK | Same as OPAMP4LK.   |
| 1         | OPAMP2LK | Same as OPAMP4LK.   |
| 0         | OPAMP1LK | Same as OPAMP4LK.   |

## 28 DVP interface (DVP)

### 28.1 Introduction

DVP is a flexible and powerful CMOS optical sensor interface, which can easily achieve the customer's image capture requirements, and the entire capture process does not require CPU intervention.

The functional characteristics of the DVP interface module are as follows:

- Pure hardware capture method;
- Pure input interface;
- Support clock output (output through MCO, typical value is 24MHz) to provide clock to external CMOS sensor;
- The polarity of input pixel clock DVP\_PCLK, frame synchronization signal DVP\_VSYNC, and horizontal synchronization signal DVP\_HSYNC can be independently configured.
- Support 8x 32bit FIFO;
- FIFO transmits 4 bytes at a time, and the transmission speed is extremely fast;
- Support DMA, no CPU intervention is required in the whole process of image capture;
- The size of the captured image must be an integer multiple of 4 bytes;
- Support hardware inversion of captured image data

### 28.2 Hardware Interface

#### 28.2.1 Pin multiplexing mode

Table 28-1 DVP pin multiplexing

| Signal    | Default Mapping | Remap 1 | Remap 3 |
|-----------|-----------------|---------|---------|
| DVP_HSYNC | PA1             | PE2     | PE2     |
| DVP_VSYNC | PA2             | PE3     | PE3     |
| DVP_PCLK  | PA3             | PE4     | PE4     |
| DVP_D0    | PA4             | PE5     | PE5     |
| DVP_D1    | PA5             | PE6     | PE6     |
| DVP_D2    | PA6             | PC0     | PC0     |
| DVP_D3    | PA7             | PB2     | PB2     |
| DVP_D4    | PC4             | PF12    | PB10    |
| DVP_D5    | PC5             | PF13    | PB11    |
| DVP_D6    | PB0             | PF14    | PF14    |
| DVP_D7    | PB1             | PF15    | PF15    |

## 28.2.2 Interface Timing

Figure 28-1 DVP interface timing example

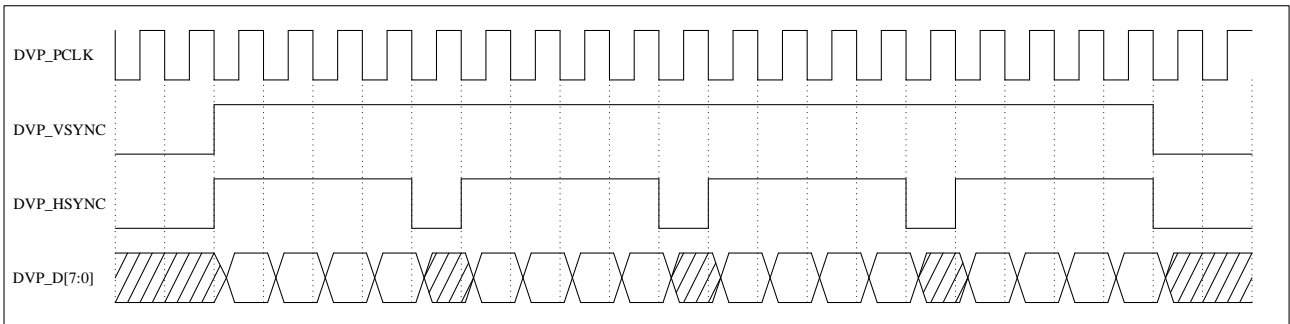

As shown in above figure:

- DVP\_PCLK is the pixel clock, and capture 1 byte (8bit) of valid data per clock cycle;
- DVP\_VSYNC is a vertical sync (frame sync) signal, active high;
- DVP\_HSYNC is the horizontal sync signal, active high;
- When DVP\_VSYNC and DVP\_HSYNC are both high level, the data is valid;
- There is a gap of at least one pixel clock cycle between every two lines;
- According to the timing in the above figure, the user needs to configure DVP\_VSYNC and DVP\_HSYNC in the DVP module to be active high and capture data on the falling edge of DVP\_PCLK to receive data correctly;
- DVP data is only valid when the capture enable bit (register DVP\_CTRL.CAPTURE) is 1, and the capture enable bit must be 1 at least 4 pixel clock cycles earlier than the DVP\_VSYNC valid signal (high level), otherwise the current frame will be discarded .

*Note: The DVP\_VSYNC and DVP\_HSYNC signals in the above figure are active high, and may also be active low in practical applications. It is necessary to configure the signal polarity in the DVP module according to the actual situation.*

## 28.3 Operating Instructions

### 28.3.1 General operation process

1. Turn on the clock of the CMOS optical sensor, enable the relevant control port (usually the I2C interface), and configure the sensor parameters;
2. DVP port and parameter configuration (for example: capture mode, window mode, DMA, etc.);
3. Configure the capture enable bit (register DVP\_CTRL.CAPTURE), ready to receive data;
4. Turn on the CMOS sensor and start sending data.

### 28.3.2 DMA application

1. Configure and enable the corresponding DMA channel (DMA2 channel 8);
2. Configure the DVP FIFO watermark value (register DVP\_CTRL.FWM) to 1 (DMA mode only supports transfers with a watermark of 1);
3. Enable DMA transfer (register DVP\_INTEN.DMAEN);
4. When the FIFO receives 1 WORD data, it will send a DMA request;
5. The DMA moves the FIFO data to the designated SRAM area.

### 28.3.3 Image size

The image size can be configured according to the user's needs (register DVP\_WSIZE), corresponding to the data size that the user can read, among which:

- VLINE is the number of valid data lines of each image frame;
- HCNT is the effective data length of each line, in bytes.

### 28.3.4 Image area

The capture area of image can be configured (register DVP\_WST), in each image frame, the user can intercept part of the data to retain as needed. The DVP module only stores the area data that needs to be reserved into the FIFO, and other data are automatically discarded:

- DVP\_WST.VST configures the starting line of the capture area;
- In the valid line, DVP\_WST.HST configures the data position of the starting pixel, calculated in bytes;
- Each register is allowed to be configured as 0.

### 28.3.5 Image scaling

The DVP module can reduce the captured image and save it (registers DVP\_CTRL.LSM, DVP\_CTRL.BSM). The first data must be the required data, and then select the data that needs to be retained as required.

- DVP\_CTRL.LSM is the line selection configuration bits. When LSM is set to 3, only keep 1 line of each 3 lines: first keep the 1st line as a valid line, and discard the 2nd and 3rd line, then keep the 4th line, discard the 5th and 6th lines, and so on, until the end of one frame.
- DVP\_CTRL.BSM is the pixel selection configuration bits calculated in bytes. Similar to LSM, when BSM is set to 4, only keep 1 byte data of each 4 bytes: first keep the 1st byte as valid data, and discard the 2nd, 3rd, 4th byte, then keep the 5th byte, discard the 6th, 7th, 8th byte, and so on, until the end of the line.

For specific configuration, please refer to the register list.

### 28.3.6 Soft reset

The DVP\_CTRL.FFSWRST controls the soft reset. The soft reset is a synchronous reset. Write 1 to reset. Because it

is a synchronous reset, it must be ensured that the input pixel clock (DVP\_PCLK) and the DVP module clock (APB2 clock PCLK2) exist at the same time.

The soft reset requires 8 PCLK2 clock cycles to synchronize. Do not operate the registers during the soft reset. The soft reset only resets the state machine, not the registers. It is recommended that users use a soft reset before each image capture.

*Note: The DVP\_CTRL.CAPTURE must be set to 0 before soft reset, and the pixel clock (DVP\_PCLK) must be clocked during this period.*

### 28.3.7 Interrupts

There are three registers related to interrupts, DVP\_INTSTS, DVP\_INTEN, DVP\_MINTSTS:

- DVP\_INTEN is the interrupt enable register.
- DVP\_INTSTS is the interrupt status register. Even if the interrupt is not enabled, the interrupt status will change, but the interrupt will not be reported to the system. The corresponding interrupt will be reported only after the corresponding interrupt enable bit in DVP\_INTEN is turned on.
- DVP\_MINTSTS is the register of interrupt status that reported to system, and users generally only use this status to check the interrupt status.
- When the user wants to use an interrupt, the corresponding flag in the register DVP\_INTSTS must be cleared (write 0 to clear) first, in order to avoid the previous state affecting of the interrupt reporting.
- There are two special flag bits in the DVP\_INTSTS register: FIFO watermark flag FWIS, FIFO full flag FFIS. These two flag bits are related to the real-time status of the FIFO and cannot be cleared by writing 0, only cleared by reading the FIFO.

### 28.3.8 Read FIFO data

FIFO data can be read directly by software, and also supports DMA or interrupt mode.

- DMA mode: when the FIFO data reaches the waterline value (FWM, must be 1), a DMA request will be generated, and the DMA will move the data to the configured SRAM;
- Interrupt mode: When the FIFO data reaches the watermark value (FWM), an interrupt will be generated, and the user will read the data through the register DVP\_FIFO

*Note: Because the data from the interface is 8 bits, but the data in the FIFO is 32 bits, the module will put the first data in the high order.*

### 28.3.9 Notes

- It must be ensured that the external CMOS optical sensor clock is turned on first, that is, DVP\_PCLK is valid.
- It must be ensured that the valid data to be captured is an integer multiple of 4 bytes.
- The configuration of watermark can only be configured as 1 when using DMA mode. (The system only supports reading one data at a time).

## 28.4 DVP register

### 28.4.1 DVP register overview

Table 28-2 DVP register overview

| Offset | Register    | 31        | 30 | 29 | 28 | 27        | 26 | 25 | 24 | 23          | 22 | 21 | 20 | 19        | 18 | 17       | 16         | 15       | 14       | 13 | 12 | 11       | 10 | 9       | 8        | 7      | 6         | 5      | 4      | 3     | 2     | 1      | 0       |       |   |   |
|--------|-------------|-----------|----|----|----|-----------|----|----|----|-------------|----|----|----|-----------|----|----------|------------|----------|----------|----|----|----------|----|---------|----------|--------|-----------|--------|--------|-------|-------|--------|---------|-------|---|---|
| 000h   | DVP_CTRL    | Reserved  |    |    |    |           |    |    |    |             |    |    |    |           |    |          | FFSWRST    | Reserved | FWM[2:0] |    |    | LSM[2:0] |    |         | BSM[2:0] |        |           | DATINV | PCKPOL | VSPOL | HSPOL | CM     | CAPTURE |       |   |   |
|        | Reset Value | 0         |    |    |    |           |    |    |    |             |    |    |    |           |    |          | 0          | 0        | 0        | 1  | 0  | 0        | 0  | 0       | 0        | 0      | 0         | 0      | 0      | 0     | 0     | 0      | 0       | 0     | 0 | 0 |
| 004h   | DVP_STS     | Reserved  |    |    |    |           |    |    |    |             |    |    |    |           |    |          |            |          |          |    |    |          |    |         |          |        | FCNT[2:0] |        |        | FNE   |       |        |         |       |   |   |
|        | Reset Value | 0         |    |    |    |           |    |    |    |             |    |    |    |           |    |          |            |          |          |    |    |          |    |         |          |        | 0         | 0      | 0      | 0     |       |        |         |       |   |   |
| 008h   | DVP_INTSTS  | Reserved  |    |    |    |           |    |    |    |             |    |    |    |           |    |          |            |          |          |    |    |          |    | HERRIS  | VERRIS   | FOIS   | FWIS      | FFIS   | FEIS   | LEIS  | LSIS  | FMEIS  | FMSIS   |       |   |   |
|        | Reset Value | 0         |    |    |    |           |    |    |    |             |    |    |    |           |    |          |            |          |          |    |    |          |    | 0       | 0        | 0      | 0         | 0      | 0      | 1     | 0     | 0      | 0       | 0     |   |   |
| 00Ch   | DVP_INTEN   | Reserved  |    |    |    |           |    |    |    |             |    |    |    |           |    |          |            |          |          |    |    |          |    | DMAEN   | HERRIE   | VERRIE | FOIE      | FWIE   | FFIE   | FEIE  | LEIE  | LSIE   | FMEIE   | FMSIE |   |   |
|        | Reset Value | 0         |    |    |    |           |    |    |    |             |    |    |    |           |    |          |            |          |          |    |    |          |    | 0       | 0        | 0      | 0         | 0      | 0      | 0     | 0     | 0      | 0       | 0     |   |   |
| 010h   | DVP_MINTSTS | Reserved  |    |    |    |           |    |    |    |             |    |    |    |           |    |          |            |          |          |    |    |          |    | HERRMIS | VERRMIS  | FOMIS  | FWMIS     | FFMIS  | FEMIS  | LEMIS | LSMIS | FMEMIS | FMSMIS  |       |   |   |
|        | Reset Value | 0         |    |    |    |           |    |    |    |             |    |    |    |           |    |          |            |          |          |    |    |          |    | 0       | 0        | 0      | 0         | 0      | 0      | 0     | 0     | 0      | 0       |       |   |   |
| 014h   | DVP_WST     | Reserved  |    |    |    |           |    |    |    | VST[10:0]   |    |    |    |           |    | Reserved | HST[10:0]  |          |          |    |    |          |    |         |          |        |           |        |        |       |       |        |         |       |   |   |
|        | Reset Value | 0         |    |    |    |           |    |    |    | 0           | 0  | 0  | 0  | 0         | 0  | 0        | 0          | 0        | 0        | 0  | 0  | 0        | 0  | 0       | 0        | 0      | 0         | 0      | 0      |       |       |        |         |       |   |   |
| 018h   | DVP_WSIZE   | Reserved  |    |    |    |           |    |    |    | VLINE[10:0] |    |    |    |           |    | Reserved | HCNT[10:0] |          |          |    |    |          |    |         |          |        |           |        |        |       |       |        |         |       |   |   |
|        | Reset Value | 0         |    |    |    |           |    |    |    | 0           | 0  | 0  | 0  | 0         | 0  | 0        | 0          | 0        | 0        | 0  | 0  | 0        | 0  | 0       | 0        | 0      | 0         | 0      | 0      |       |       |        |         |       |   |   |
| 01Ch   | DVP_FIFO    | DAT3[7:0] |    |    |    | DAT2[7:0] |    |    |    | DAT1[7:0]   |    |    |    | DAT0[7:0] |    |          |            |          |          |    |    |          |    |         |          |        |           |        |        |       |       |        |         |       |   |   |
|        | Reset Value | 0         | 0  | 0  | 0  | 0         | 0  | 0  | 0  | 0           | 0  | 0  | 0  | 0         | 0  | 0        | 0          | 0        | 0        | 0  | 0  | 0        | 0  | 0       | 0        | 0      | 0         | 0      | 0      | 0     | 0     |        |         |       |   |   |

### 28.4.2 DVP Control Register (DVP\_CTRL)

Address offset : 0x00

Reset value : 0x0000 1000

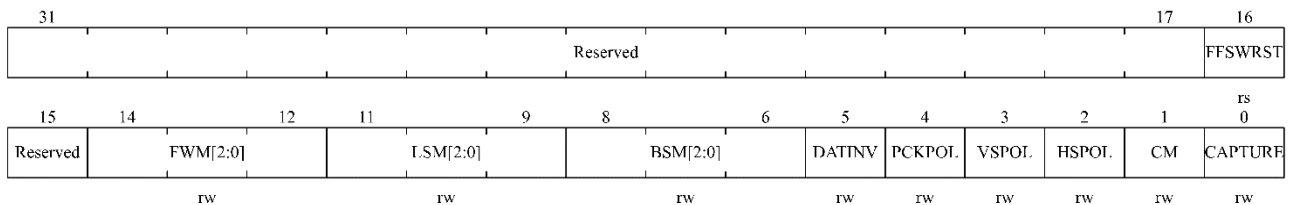

| Bit field | Name     | Description  |
|-----------|----------|--|
| 31:17     | Reserved | Reserved, the reset value must be maintained.  |
| 16        | FFSWRST  | FIFO soft reset enable bit.<br>Set to 1 by software and cleared to 0 by hardware. When resetting, it must be ensured |

| Bit field | Name     | Description   |
|-----------|----------|---|
|           |          | <p>that both DVP_PCLK and PCLK2 are provided normally, at least 8 PCLK2 clock cycles can be guaranteed to reset successfully, and the DVP module register can be operated after the reset is completed. Soft reset only resets the internal logic of the DVP module, not the registers.</p> <p>0: No effect<br/>1: enable soft reset</p>  |
| 15        | Reserved | Reserved, the reset value must be maintained.   |
| 14:12     | FWM[2:0] | <p>FIFO watermark value.</p> <p>DMA or interrupt is triggered when the data length in the FIFO reaches this value.</p>  |
| 11:9      | LSM[2:0] | <p>Line selection mode.</p> <p>000: capture all lines<br/>001: Capture 1 line of each 2 lines<br/>010: Capture 1 line of each 3 lines<br/>011: Capture 1 line of each 4 lines<br/>100: Capture 1 line of each 5 lines<br/>101: Capture 1 line of each 6 lines<br/>110: Capture 1 line of each 7 lines<br/>111: Capture 1 line of each 8 lines</p>   |
| 8:6       | BSM[2:0] | <p>Byte selection mode.</p> <p>Indicates the proportion of valid pixels extracted and retained in each line of data, calculated in bytes, only applicable to the case where the pixel data does not exceed 1 byte. For example, when the input data is in RGB565 format, 1 pixel occupies 2 bytes, and the byte selection mode is not supported.</p> <p>000: capture all pixels<br/>001: Capture 1 pixel of each 2 pixels<br/>010: Capture 1 pixel of each 3 pixels<br/>011: Capture 1 pixel of each 4 pixels<br/>100: Capture 1 pixel of each 5 pixels<br/>101: Capture 1 pixel of each 6 pixels<br/>110: Capture 1 pixel of each 7 pixels<br/>111: Capture 1 pixel of each 8 pixels</p> |
| 5         | DATINV   | <p>Data inversion.</p> <p>0: Data is not inverted<br/>1: Data is inverted</p>   |
| 4         | PCKPOL   | <p>Pixel clock polarity.</p> <p>This bit is used to configure the capture edge of the pixel clock.</p> <p>0: Capture on falling edge<br/>1: Capture on rising edge</p>  |
| 3         | VSPOL    | <p>Vertical sync signal polarity.</p> <p>This bit indicates the level of the VSYNC pin when there is valid data on the parallel interface.</p> <p>0: VSYNC active low<br/>1: VSYNC active high</p>  |

| Bit field | Name    | Description  |
|-----------|---------|--|
| 2         | HSPOL   | Horizontal sync polarity.<br>This bit indicates the level of the HSYNC pin when there is valid data on the parallel interface.<br>0: HSYNC active low<br>1: HSYNC active high  |
| 1         | CM      | capture mode.<br>0: Single frame mode. Once activated, the interface waits for the frame sync signal to be valid, and then starts transmitting data. After a frame of data is transmitted, the CAPTURE bit is automatically cleared.<br>1: Continuous mode. After transmitting a frame of data, the CAPTURE bit is not cleared and continues to wait for the next frame synchronization signal.  |
| 0         | CAPTURE | Capture enable.<br>In single frame mode, this bit is automatically cleared to 0 after the first frame is received. In continuous mode, it needs to be cleared by software. If the software clears 0 while the capture is in progress, this bit is not cleared until the current frame is captured.<br>0: Disable capture function<br>1: Enable capture function<br><i>Note: Before enabling capture, the DMA controller and DVP configuration registers must be properly configured as required.</i> |

### 28.4.3 DVP Status Register (DVP\_STS)

Address offset : 0x04

Reset value : 0x0000 0000

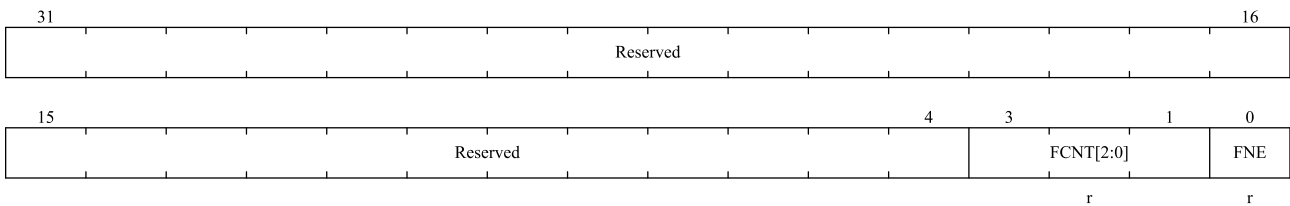

| Bit field | Name      | Description  |
|-----------|-----------|--|
| 31:4      | Reserved  | Reserved, the reset value must be maintained.                                  |
| 3:1       | FCNT[2:0] | Length of data in FIFO.  |
| 0         | FNE       | FIFO not empty flag.<br>0: FIFO is empty<br>1: There is valid data in the FIFO |

### 28.4.4 DVP Interrupt Status Register (DVP\_INTSTS)

Address offset : 0x08

Reset value : 0x0000 0010

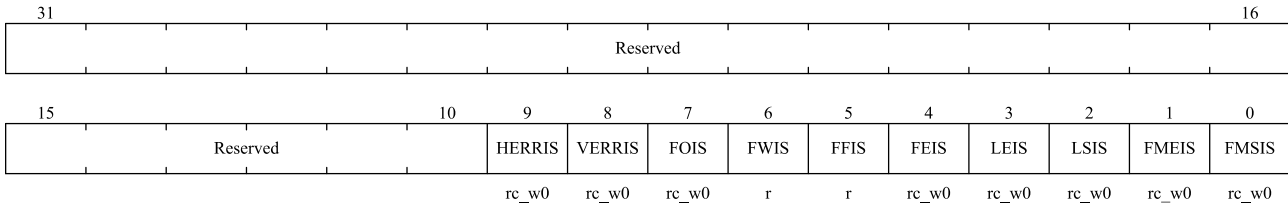

| Bit field | Name     | Description  |
|-----------|----------|--|
| 31:10     | Reserved | Reserved, the reset value must be maintained.  |
| 9         | HERRIS   | HSYNC error status.<br>Software write 0 to clear. When the received row data is smaller than the configured data size per line, an HSYNC error is generated (HSYNC arrives early).<br>0: No error<br>1: There is an HSYNC error                                    |
| 8         | VERRIS   | VSYNC error status.<br>Software write 0 to clear. When the number of received data lines is less than the configured number of data lines per frame, a VSYNC error is generated (VSYNC arrives early)<br>0: No error<br>1: There is a VSYNC error                  |
| 7         | FOIS     | FIFO overflow status.<br>Software write 0 to clear. This bit needs to be cleared manually.<br>0: FIFO has not overflowed<br>1: FIFO overflow   |
| 6         | FWIS     | FIFO watermark status.<br>This bit is related to the real-time status of the FIFO and can only be cleared by reading the FIFO.<br>0: The data length in the FIFO has not reached DVP_CTRL.FWM[2:0]<br>1: The data length in the FIFO has reached DVP_CTRL.FWM[2:0] |
| 5         | FFIS     | FIFO full status.<br>This bit is related to the real-time status of the FIFO and can only be cleared by reading the FIFO.<br>0: FIFO is not full<br>1: FIFO is full  |
| 4         | FEIS     | FIFO is empty.<br>Software write 0 to clear. This bit needs to be cleared manually.<br>0: FIFO is not empty<br>1: FIFO is empty  |
| 3         | LEIS     | End of line status.<br>Software write 0 to clear.<br>0: Line not ended.<br>1: Line has ended.  |
| 2         | LSIS     | row start state.<br>Software write 0 to clear.<br>0: Line not started.   |

| Bit field | Name  | Description  |
|-----------|-------|--|
|           |       | 1: Line has started.   |
| 1         | FMEIS | Frame end state.<br>Software write 0 to clear.<br>0: Frame not ended.<br>1: Frame has ended.       |
| 0         | FMSIS | Frame start state.<br>Software write 0 to clear.<br>0: Frame not started.<br>1: Frame has started. |

## 28.4.5 DVP Interrupt Enable Register

Address offset : 0x0c

Reset value : 0x0000 0000

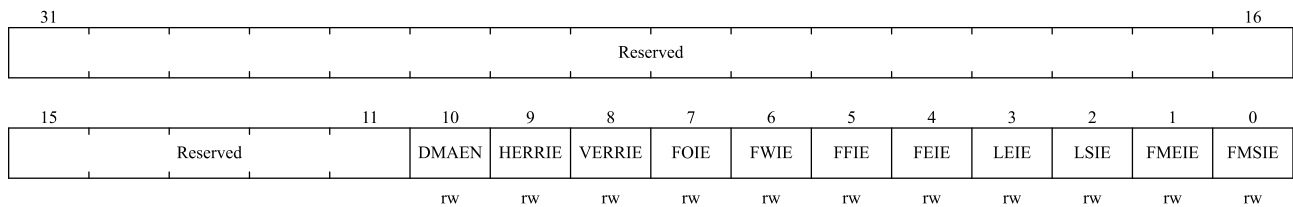

| Bit field | Name     | Description  |
|-----------|----------|--|
| 31:11     | Reserved | Reserved, the reset value must be maintained.  |
| 10        | DMAEN    | DMA enable bit.<br>When this bit is enabled, a DMA request will be generated when the data length of the FIFO reaches the watermark.<br>0: DMA is not enabled.<br>1: DMA is enabled. |
| 9         | HERRIE   | HSYNC error interrupt enable.<br>0: Disable HSYNC error interrupt<br>1: Enable HSYNC error interrupt   |
| 8         | VERRIE   | VSYNC error interrupt enable.<br>0: Disable VSYNC error interrupt<br>1: Enable VSYNC error interrupt   |
| 7         | FOIE     | FIFO overflow interrupt enable.<br>0: Disable FIFO overflow interrupt<br>1: Enable FIFO overflow interrupt   |
| 6         | FWIE     | FIFO watermark interrupt enable.<br>0: Disable FIFO watermark interrupt<br>1: Enable FIFO waterline interrupt  |
| 5         | FFIE     | FIFO full interrupt enable.<br>0: Disable FIFO full interrupt<br>1: Enable FIFO full interrupt   |

| Bit field | Name  | Description  |
|-----------|-------|--|
| 4         | FEIE  | FIFO empty interrupt enable.<br>0: Disable FIFO empty interrupt<br>1: Enable FIFO empty interrupt              |
| 3         | LEIE  | End of line interrupt enable.<br>0: End-of-line interrupt is not enabled<br>1: Enable end-of-line interrupt    |
| 2         | LSIE  | Line start interrupt enable.<br>0: Disable line start interrupt<br>1: Enable line start interrupt              |
| 1         | FMEIE | End of frame interrupt enable.<br>0: End-of-frame interrupt is not enabled<br>1: Enable end-of-frame interrupt |
| 0         | FMSIE | Start of Frame Interrupt Enable.<br>0: Disable start of frame interrupt<br>1: Enable frame start interrupt     |

### 28.4.6 DVP interrupt trigger status register (DVP\_MINTSTS)

Address offset : 0x10

Reset value : 0x0000 0000

When there is an interrupt in the system, this register should be polled to determine which interrupt it is. The corresponding interrupt flag in this register is valid only when both the interrupt enable and interrupt status bits are valid. The interrupt flag can be cleared by clearing the corresponding bit in the interrupt status register DVP\_INTSTS.

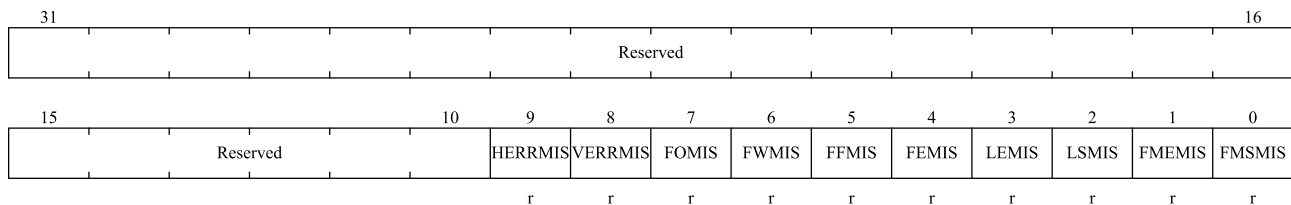

| Bit field | Name     | Description  |
|-----------|----------|--|
| 31:10     | Reserved | Reserved, the reset value must be maintained.  |
| 9         | HERRMIS  | HSYNC error interrupt trigger status.<br>0: No HSYNC error.<br>1: HSYNC error interrupt triggered.   |
| 8         | VERRMIS  | VSYNC error interrupt trigger status.<br>0: No VSYNC error.<br>1: VSYNC error interrupt triggered.   |
| 7         | FOMIS    | FIFO overflow interrupt trigger status.<br>Software write 0 to clear. This bit needs to be cleared manually.<br>0: FIFO has not overflowed.<br>1: FIFO overflow interrupt triggered. |

| Bit field | Name   | Description  |
|-----------|--------|--|
| 6         | FWMIS  | FIFO watermark interrupt status.<br>This bit is related to the real-time status of the FIFO and can only be cleared by reading the FIFO.<br>0: The data length in the FIFO has not reached DVP_CTRL.FWM[2:0].<br>1: The data length in the FIFO has reached DVP_CTRL.FWM[2:0] and interrupt triggered. |
| 5         | FFMIS  | FIFO full interrupt status.<br>This bit is related to the real-time status of the FIFO and can only be cleared by reading the FIFO.<br>0: FIFO is not full.<br>1: FIFO is full and interrupt triggered.  |
| 4         | FEMIS  | FIFO empty interrupt state.<br>Software write 0 to clear. This bit needs to be cleared manually.<br>0: FIFO is not empty<br>1: FIFO is empty and interrupt triggered.  |
| 3         | LEMIS  | End of line interrupt status.<br>Software write 0 to clear.<br>0: Line not ended.<br>1: Line has ended and interrupt triggered.  |
| 2         | LSMIS  | Line start interrupted state.<br>Software write 0 to clear.<br>0: Line not started.<br>1: Line has started and interrupt triggered.  |
| 1         | FMEMIS | End of frame interrupt status.<br>Software write 0 to clear.<br>0: Frame not ended.<br>1: Frame has ended and interrupt triggered.   |
| 0         | FMSMIS | Frame start interrupted state.<br>Software write 0 to clear.<br>0: Frame not started.<br>1: Frame has started and interrupt triggered.   |

### 28.4.7 DVP image start register (DVP\_WST)

Address offset : 0x14

Reset value : 0x0000 0000

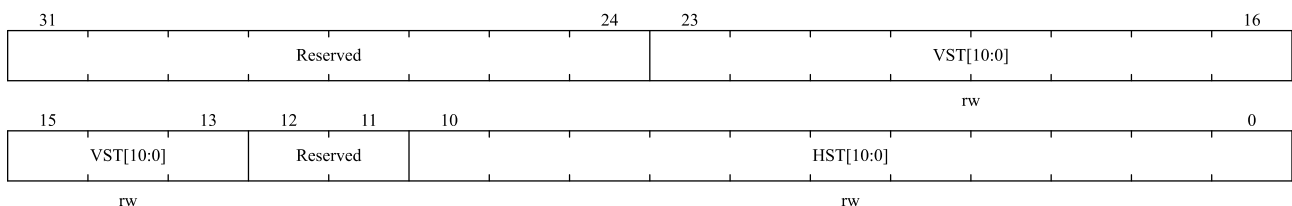

| Bit field | Name      | Description   |
|-----------|-----------|---|
| 31:24     | Reserved  | Reserved, the reset value must be maintained.       |
| 23:13     | VST[10:0] | Start line number, the first line starts at 0.      |
| 12:11     | Reserved  | Reserved, the reset value must be maintained.       |
| 10:0      | HST[10:0] | Starting pixel number, the first pixel starts at 0. |

### 28.4.8 DVP image size register (DVP\_WSIZE)

Address offset : 0x18

Reset value : 0x0000 0000

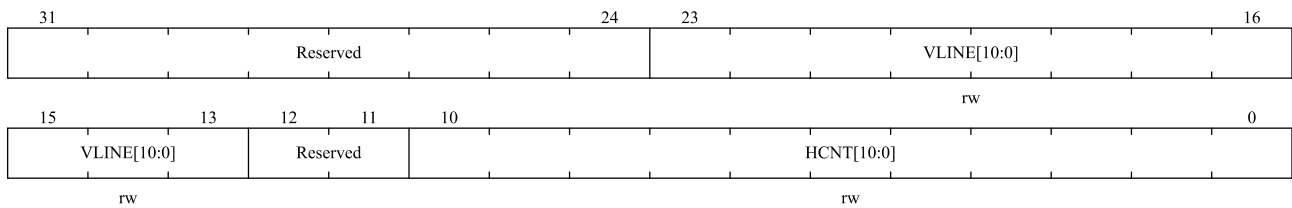

| Bit field | Name        | Description   |
|-----------|-------------|---|
| 31:24     | Reserved    | Reserved, the reset value must be maintained.       |
| 23:13     | VLINE[10:0] | The number of lines per frame.                      |
| 12:11     | Reserved    | Reserved, the reset value must be maintained.       |
| 10:0      | HCNT[10:0]  | The number of pixels per line, calculated in bytes. |

### 28.4.9 DVP FIFO register (DVP\_FIFO)

Address offset : 0x1c

Reset value : 0x0000 0000

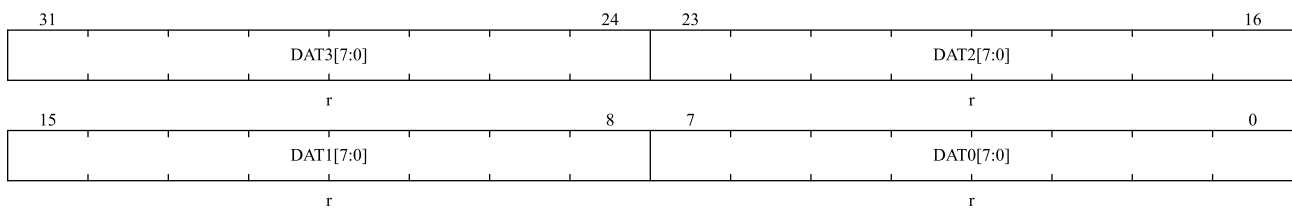

| Bit field | Name      | Description |
|-----------|-----------|-------------|
| 31:24     | DAT3[7:0] | Data byte 3 |
| 23:16     | DAT2[7:0] | Data byte 2 |
| 15:8      | DAT1[7:0] | Data byte 1 |
| 7:0       | DAT0[7:0] | Data byte 0 |

## 29 Debug support (DBG)

### 29.1 Overview

N32G45x uses Cortex™-M4F core, which integrates hardware debugging module. Support instruction breakpoint (stop when instruction fetches value) and data breakpoint (stop when data access). When the kernel is stopped, the user can view the internal state of the kernel and the external state of the system. After the user's query operation is completed, the kernel and peripherals can be restored, and the corresponding program can continue to be executed. The hardware debugging module of the N32G45x kernel can be used when it is connected to the debugger (when it is not disabled).

N32G45x supports the following debugging interfaces:

- Serial wire
- JTAG debugging interface

Figure 29-1 N32G45x level and Cortex™-M4F level debugging block diagram

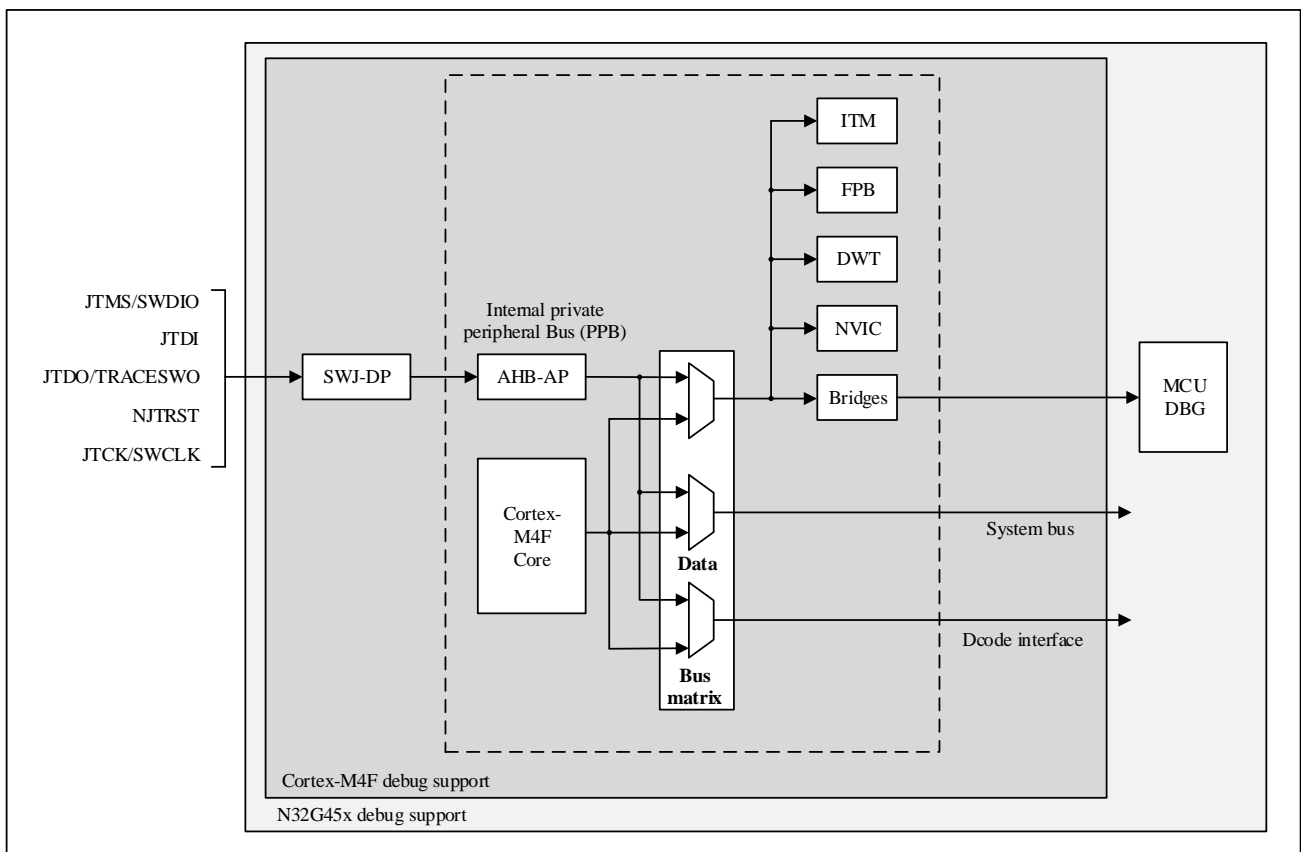

The ARM Cortex™-M4F core hardware debugging module can provide the following debugging functions:

- SWJ-DP: serial /JTAG debug port
- AHP-AP: AHB access port
- ITM: execution tracking unit
- FPB: Flash instruction breakpoint

- DWT: data trigger

Reference:

- Cortex™-M4 Technical Reference Manual (TRM)
- ARM debugging interface V5 structure specification
- ARM CoreSight development tool set (r1p0 version) technical reference manual

The system supports low-power mode debugging and debugging of some peripherals. The peripherals supporting debugging include: CAN, I2C interface and TIMER, WWDG and IWDG modules. The user needs to set the corresponding bit of the debug control register (DBG\_CTRL) to 1 when debugging with low power consumption or peripherals.

## 29.2 JTAG/SWD function

The debugging tool can call the debugging function through the SWD debugging interface or JTAG debugging interface mentioned above.

### 29.2.1 Switch JTAG/SWD interface

The chip uses JTAG debug interface by default. If you need to switch the debug interface, you can switch between SWD interface and JTAG interface through the following operations:

JTAG debug to SWD debug switch:

1. Sending JTMS = 1 signals with more than 50 JTCK cycles;
2. Send 16-bit JTMS = 1110011110011110(0xE79E LSB) signal;
3. Send JTMS = 1 signal with more than 50 JTCK cycles.

Switch from SWD debugging to JTAG debugging:

1. Sending JTMS = 1 signals with more than 50 JTCK cycles;
2. Send 16-bit JTMS = 1110011100111100(0xE73C LSB) signal;
3. Send JTMS = 1 signal with more than 50 JTCK cycles.

### 29.2.2 Pin allocation

JTAG debugging interface includes five pins: JTCK(JTAG clock pin), JTMS(JTAG mode selection pin), JTDI(JTAG data input pin), JTDO(JTAG data output pin) and NJTRST(JTAG data reset pin, low level reset pin).

SWD (serial debugging) interface includes two pins: SWCLK (clock pin) and SWDIO (data input and output pin), which provide the interface of two pins: data input and output pin (SWDIO) and clock pin (SWCLK).

See the following Table for the pin allocation of JTAG debugging interface and SWD debugging interface (SWDIO is multiplexed with JTMS, SWCLK is multiplexed with JTCK):

Table 29-1 Debug port pin

| Debug port | Pin allocation |
|------------|----------------|
|------------|----------------|

|            |      |
|------------|------|
| JTMS/SWDIO | PA13 |
| JTCK/SWCLK | PA14 |
| JTDI       | PA15 |
| JTDO       | PB3  |
| NJTRST     | PB4  |

- When both JTAG debugging interface and SWD debugging interface are enabled, the 5-wire JTAG debugging interface will be used by default after reset.
- When using JTAG interface, users can not use NJTRST pin. In this case, NJTRST pin (PB4, internal hardware pull-up) can be used as a general-purpose GPIO.
- When SWD interface is used, three pins JTDI(PA15), JTDO(PB3) and NJTRST(PB4) can be used as general GPIO.
- When the debugging function is not used, the above five pins can be used as general-purpose GPIO.

## 29.3 MCU debugging function

### 29.3.1 Low power mode support

N32G45x can provide a variety of low power consumption modes (refer to Power control (PWR) for details). When debugging, ensure that the FCLK and HCLK of the kernel are on, and provide the necessary clock for kernel debugging. Users can debug MCU in low power mode according to specific operation (ensuring the output of FCLK or HCLK in low power mode).

If users want to debug MCU in low power mode, they first need the debugger to configure registers related to low power mode:

- **DBG\_SLEEP mode:**  
The DBG\_CTRL.SLEEP bit needs to be configured to provide HCLK with the same clock as provided to FCLK (ie: the original configured system clock).
- **DBG\_STOP mode:**  
The DBG\_CTRL.STOP bit needs to be configured to start the internal RC oscillator to provide the clock for HCLK and FCLK.
- **DBG\_STANDBY mode:**  
The DBG\_CTRL.STDBY bit needs to be configured to start the internal RC oscillator to provide the clock for HCLK and FCLK.

### 29.3.2 Peripheral debugging support

When the corresponding bit of the peripheral control bit in the DBG\_CTRL register is set to 1, the corresponding peripheral enters the debugging state after the kernel stops:

- **Timer peripheral:** the timer counter stops and debugs;
- **I2C peripheral:** the SMBUS of I2C keeps the state and carries out debugging;

- WWDG/IWDG peripheral: WWDG/IWDG counter clock stops and debugs;
- CAN peripheral: the CAN interface receiving register stops counting and debugs.

## 29.4 DBG registers

### 29.4.1 DBG register overview

These peripheral registers must be operated as words (32 bits). The base address of the register is 0xE004 2000.

Table 29-2 DBG register overview

| Offset | Register    | 31        | 30 | 29 | 28 | 27       | 26 | 25 | 24 | 23             | 22 | 21 | 20 | 19         | 18 | 17 | 16 | 15             | 14 | 13 | 12 | 11             | 10        | 9         | 8         | 7              | 6                 | 5                 | 4         | 3              | 2         | 1         | 0         |           |           |          |   |  |  |       |      |       |
|--------|-------------|-----------|----|----|----|----------|----|----|----|----------------|----|----|----|------------|----|----|----|----------------|----|----|----|----------------|-----------|-----------|-----------|----------------|-------------------|-------------------|-----------|----------------|-----------|-----------|-----------|-----------|-----------|----------|---|--|--|-------|------|-------|
| 000h   | DBG_ID      | SRAM[3:0] |    |    |    | Reserved |    |    |    | DEV_NUM_L[3:0] |    |    |    | FLASH[3:0] |    |    |    | DEV_NUM_H[3:0] |    |    |    | DEV_NUM_M[3:0] |           |           |           | REV_NUM_H[3:0] |                   |                   |           | REV_NUM_L[3:0] |           |           |           |           |           |          |   |  |  |       |      |       |
|        | Reset Value | x         | x  | x  | x  |          |    |    |    | x              | x  | x  | x  | x          | x  | x  | x  | x              | x  | x  | x  | x              | x         | x         | x         | x              | x                 | x                 | x         | x              | x         | x         | x         | x         | x         | x        | x |  |  |       |      |       |
| 004h   | DBG_CTRL    | Reserved  |    |    |    |          |    |    |    |                |    |    |    |            |    |    |    |                |    |    |    | CAN2_STOP      | TIM7_STOP | TIM6_STOP | TIM5_STOP | TIM8_STOP      | I2C2SMBUS_TIMEOUT | I2C1SMBUS_TIMEOUT | CAN1_STOP | TIM4_STOP      | TIM3_STOP | TIM2_STOP | TIM1_STOP | WWDG_STOP | IWDG_STOP | Reserved |   |  |  | STDBY | STOP | SLEEP |
|        | Reset Value |           |    |    |    |          |    |    |    |                |    |    |    |            |    |    |    |                |    |    |    | 0              | 0         | 0         | 0         | 0              | 0                 | 0                 | 0         | 0              | 0         | 0         | 0         | 0         | 0         |          |   |  |  | 0     | 0    | 0     |

### 29.4.2 ID register (DBG\_ID)

Address offset: 0x04

Only 32-bit access is supported, and fixed values cannot be modified

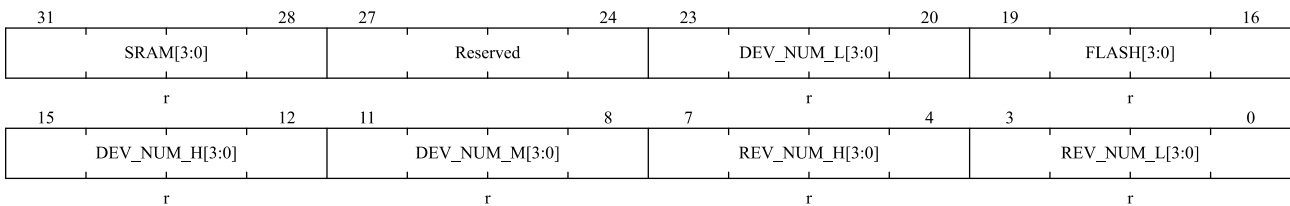

| Bit field | Name           | Description   |
|-----------|----------------|---|
| 31:28     | SRAM[3:0]      | SRAM capacity.<br>The chip SRAM capacity is (SRAM[3:0] + 1) * 16KB  |
| 27:24     | Reserved       | Reserved, must keep the reset value.  |
| 23:20     | DEV_NUM_L[3:0] | Lower 4 digits of device model.<br>Device model consists of 12 bits, including high, medium and low, representing the model of MCU. The values are as follows: <ul style="list-style-type: none"> <li>■ 0x451: N32G451</li> <li>■ 0x452: N32G452</li> <li>■ 0x455: N32G455</li> <li>■ 0x457: N32G457</li> </ul> |



| Bit field | Name      | Description  |
|-----------|-----------|--|
|           |           | 1: The counter of the selected timer stops working.  |
| 9         | WWDG_STOP | <p>When the kernel enters the debug state, the debug window watchdog stops working.</p> <p>Set or cleared by software.</p> <p>0: The window watchdog counter still works normally;</p> <p>1: Window watchdog counter stops working.</p>  |
| 8         | IWDG_STOP | <p>The watchdog stops working when the kernel enters the debugging state.</p> <p>Set or cleared by software.</p> <p>0: Watchdog counter still works normally;</p> <p>1: Watchdog counter stops working.</p>  |
| 7:3       | Reserved  | Reserved, must keep the reset value.   |
| 2         | STDBY     | <p>Debug standby mode.</p> <p>Set or cleared by software.</p> <p>0: (FCLK OFF, HCLK OFF) The whole digital circuit is powered off. From the software point of view, exiting the STANDBY mode is the same as resetting (except that some status bits indicate that the microcontroller has just exited from the STANDBY state).</p> <p>1: (FCLK ON, HCLK ON) The digital circuit part is not powered down, and the FCLK and HCLK clocks are clocked by the internal RLD oscillator. In addition, it is the same as resetting that the microcontroller exits the STANDBY mode by generating a system reset.</p>  |
| 1         | STOP      | <p>Debug stop mode.</p> <p>Set or cleared by software.</p> <p>0: (FCLK OFF, HCLK OFF) In stop mode, the clock controller disables all clocks (including HCLK and FCLK). When exiting from STOP mode, the configuration of the clock is the same as that after reset (the microcontroller is clocked by the 8MHz internal RC oscillator (HSI)). Therefore, the software must reconfigure the clock control system to start PLL, crystal oscillator, etc.</p> <p>1: (FCLK ON, HCLK ON) In stop mode, the FCLK and HCLK clocks are provided by the internal RC oscillator. When exiting the stop mode, the software must reconfigure the clock system to start PLL, crystal oscillator, etc. (the same operation as when this bit is set to 0).</p> |
| 0         | SLEEP     | <p>Debug sleep mode.</p> <p>Set or cleared by software.</p> <p>0: (FCLK is ON, HCLK is OFF) In sleep mode, FCLK is provided by the previously configured system clock, while HCLK is off. Since sleep mode does not reset the configured clock system, the software does not need to reconfigure the clock system when exiting from sleep mode.</p> <p>1: (FCLK ON, HCLK ON) In sleep mode, both the FCLK and HCLK clocks are provided by the previously configured system clock.</p>  |

## **30 Unique device serial number (UID)**

### **30.1 Introduction**

MCU series products have two built-in unique device serial numbers with different lengths, namely 96-bit UID (Unique device ID) and 128-bit UCID (Unique Customer ID). These two device serial numbers are stored in the system configuration block of the flash memory, and the information is programmed during manufacture, and any MCU microcontroller is guaranteed to be unique under any circumstances. It can be read by user applications or external devices through CPU or SWD interface and cannot be modified.

UID is 96 bits, which is usually used as serial number or password. When writing flash memory, this unique identifier is combined with software encryption and decryption algorithm to further improve the security of code in flash memory.

UCID is 128 bits and complies with the definition of the NSING Technologies chip serial number. It contains information about chip production and version.

### **30.2 UID register**

Start address: 0x1FFF\_F7F0, 96 bits in length.

### **30.3 UCID register**

Start address: 0x1FFF\_F7C0, 128 bits in length.

## 31 Version history

| Date       | Version | Remark  |
|------------|---------|---|
| 2022.7.8   | V3.0    | Initial version   |
| 2022.09.07 | V3.1.0  | <ol style="list-style-type: none"> <li>1. Modify VERF to VREF in chapter 26.5</li> <li>2. Section 7.2.5.7, add TIMx_ETR</li> <li>3. Figure 12-1, Add description of ETR</li> <li>4. Delete RTC periodic wake-up support Standby mode.</li> <li>5. Modify PVD threshold gear information description error.</li> <li>6. Modify Figure 21-25 I2S clock generator structure.</li> <li>7. Modify ADC sampling clock and sampling rate</li> <li>8. Add Clock Tree Figure note: When PLL is selected as system clock source, PLL minimum clock output is 32MHz</li> <li>9. Added comments to the I2C master send/receive mode chapter</li> </ol>      |
| 2024.11.20 | V3.2.0  | <ol style="list-style-type: none"> <li>1. Modify Table 3-4</li> <li>2. Modify Table 7-43, USART_RX GPIO configuration</li> <li>3. Chapter 8.4.11 add note</li> <li>4. Chapter 9.6 add note</li> <li>5. Modify 10.4.9 chapter configuration process</li> <li>6. Modify 14.2.6 and 14.2.7 chapter, add note when calendar initialization and calendar reading</li> <li>7. Chapter 19.3 add note</li> <li>8. Modify 20.4.5 chapter typo</li> <li>9. Modify figure 20-9</li> <li>10. Chapter 23.4.2.5 add note</li> <li>11. Modify 23.4.3.7 chapter, modify generate error condition</li> <li>12. Modify 23.7.2 chapter bit3 description</li> </ol> |
| 2025.06.05 | V3.3.0  | <ol style="list-style-type: none"> <li>1. Modify the description of section 14.2.18, RTC wakeup event can not wake up standby mode</li> <li>2. Modify the description of Table 4-1, high level wakes up standby mode</li> </ol>   |

|            |        |  |
|------------|--------|--|
|            |        | <ol style="list-style-type: none"> <li>3. Modify the description of section 4.2.4.2, high level wakes up standby mode</li> <li>4. Modify the bit field of SDIO_CLKCTRL.DIV in section 18.7.3</li> <li>5. Modify the DMA description in section 18.3.2.2, the DMA channel of SDIO is DMA2_CH4</li> <li>6. Modify the PWR_CTRL.MSB voltage parameter in section 4.4.2</li> <li>7. Add note in section 4.2.3.2</li> </ol>   |
| 2025.09.17 | V3.4.0 | <ol style="list-style-type: none"> <li>1. Add a note in section 14.2.17.</li> <li>2. Add a note in section 8.4.6</li> <li>3. Add a note in USART_STS_OREF</li> <li>4. Modify the note of section 22.3.2.6</li> <li>5. Modify Table 7-43</li> <li>6. Modify the description of TIMx_CTRL2.CCPCTL</li> <li>7. Modify Table 7-37</li> <li>8. Modify Figure 27-8</li> <li>9. Modify the description of RTC_WKUPT.WKUPT</li> <li>10. Add a note in section 7.2.5.4</li> </ol> |
| 2026.02.26 | V3.5.0 | <ol style="list-style-type: none"> <li>1. Remove the description that the maximum SysTick clock is HCLK/8</li> <li>2. Add a note in section 3.2.2.3.3</li> <li>3. Modify the description of RTC_WKUPT.WKUPT</li> <li>4. Modify the description of FLASH_AC.LATENCY</li> <li>5. Add a note in section 3.2.1.4.2</li> <li>6. Add a note in section 8.2</li> <li>7. Add a note in section 7.2.5.2</li> <li>8. Modify the description of DBG_ID.DEV_NUM_L[3:0]</li> </ol>    |

## 32 Notice

This document is the exclusive property of NSING TECHNOLOGIES PTE. LTD. (Hereinafter referred to as NSING). This document, and the product of NSING described herein (Hereinafter referred to as the Product) are owned by NSING under the laws and treaties of Republic of Singapore and other applicable jurisdictions worldwide. The intellectual properties of the product belong to NSING Technologies Inc. and NSING Technologies Inc. does not grant any third party any license under its patents, copyrights, trademarks, or other intellectual property rights. Names and brands of third party may be mentioned or referred thereto (if any) for identification purposes only. NSING reserves the right to make changes, corrections, enhancements, modifications, and improvements to this document at any time without notice. Please contact NSING and obtain the latest version of this document before placing orders. Although NSING has attempted to provide accurate and reliable information, NSING assumes no responsibility for the accuracy and reliability of this document. It is the responsibility of the user of this document to properly design, program, and test the functionality and safety of any application made of this information and any resulting product. In no event shall NSING be liable for any direct, indirect, incidental, special, exemplary, or consequential damages arising in any way out of the use of this document or the Product. NSING Products are neither intended nor warranted for usage in systems or equipment, any malfunction or failure of which may cause loss of human life, bodily injury or severe property damage. Such applications are deemed, 'Insecure Usage'. Insecure usage includes, but is not limited to: equipment for surgical implementation, atomic energy control instruments, airplane or spaceship instruments, all types of safety devices, and other applications intended to supporter sustain life. All Insecure Usage shall be made at user's risk. User shall indemnify NSING and hold NSING harmless from and against all claims, costs, damages, and other liabilities, arising from or related to any customer's Insecure Usage Any express or implied warranty with regard to this document or the Product, including, but not limited to. The warranties of merchantability, fitness for a particular purpose and non-infringement are disclaimed to the fullest extent permitted by law. Unless otherwise explicitly permitted by NSING, anyone may not use, duplicate, modify, transcribe or otherwise distribute this document for any purposes, in whole or in part.